

CAREERS 360
PRACTICE Series

GATE 2024

Chemical Engineering
Question Paper & Answer Key

General Aptitude (GA)

Q.1 – Q.5 Carry ONE mark Each

Q.1	If '→' denotes increasing order of intensity, then the meaning of the words [simmer → seethe → smolder] is analogous to [break → raze → _____]. Which one of the given options is appropriate to fill the blank?
(A)	obfuscate
(B)	obliterate
(C)	fracture
(D)	fissure

Q.2	<p>In a locality, the houses are numbered in the following way:</p> <p>The house-numbers on one side of a road are consecutive odd integers starting from 301, while the house-numbers on the other side of the road are consecutive even numbers starting from 302. The total number of houses is the same on both sides of the road.</p> <p>If the difference of the sum of the house-numbers between the two sides of the road is 27, then the number of houses on each side of the road is</p>
(A)	27
(B)	52
(C)	54
(D)	26
Q.3	<p>For positive integers p and q, with $\frac{p}{q} \neq 1$, $\left(\frac{p}{q}\right)^{\frac{p}{q}} = p^{\left(\frac{p}{q}-1\right)}$. Then,</p>
(A)	$q^p = p^q$
(B)	$q^p = p^{2q}$
(C)	$\sqrt{q} = \sqrt{p}$
(D)	${}^p\sqrt{q} = {}^q\sqrt{p}$

Q.4	Which one of the given options is a possible value of x in the following sequence? 3, 7, 15, x , 63, 127, 255
(A)	35
(B)	40
(C)	45
(D)	31
Q.5	On a given day, how many times will the second-hand and the minute-hand of a clock cross each other during the clock time 12:05:00 hours to 12:55:00 hours?
(A)	51
(B)	49
(C)	50
(D)	55

Q.6 – Q.10 Carry TWO marks Each

<p>Q.6</p>	<p>In the given text, the blanks are numbered (i)–(iv). Select the best match for all the blanks.</p> <p>From the ancient Athenian arena to the modern Olympic stadiums, athletics _____⁽ⁱ⁾_____ the potential for a spectacle. The crowd _____⁽ⁱⁱ⁾_____ with bated breath as the Olympian artist twists his body, stretching the javelin behind him. Twelve strides in, he begins to cross-step. Six cross-steps _____⁽ⁱⁱⁱ⁾_____ in an abrupt stop on his left foot. As his body _____^(iv)_____ like a door turning on a hinge, the javelin is launched skyward at a precise angle.</p>
(A)	(i) hold (ii) waits (iii) culminates (iv) pivot
(B)	(i) holds (ii) wait (iii) culminates (iv) pivot
(C)	(i) hold (ii) wait (iii) culminate (iv) pivots
(D)	(i) holds (ii) waits (iii) culminate (iv) pivots

Q.7	<p>Three distinct sets of indistinguishable twins are to be seated at a circular table that has 8 identical chairs. Unique seating arrangements are defined by the relative positions of the people.</p> <p>How many unique seating arrangements are possible such that each person is sitting next to their twin?</p>
(A)	12
(B)	14
(C)	10
(D)	28

Q.8 The chart given below compares the Installed Capacity (MW) of four power generation technologies, T1, T2, T3, and T4, and their Electricity Generation (MWh) in a time of 1000 hours (h).

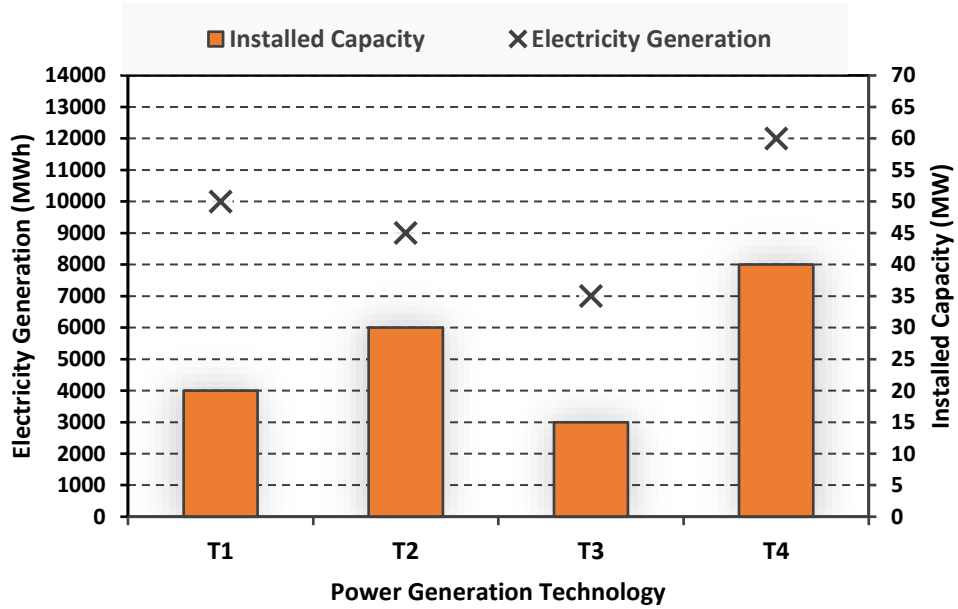

The Capacity Factor of a power generation technology is:

$$\text{Capacity Factor} = \frac{\text{Electricity Generation (MWh)}}{\text{Installed Capacity (MW)} \times 1000 \text{ (h)}}$$

Which one of the given technologies has the highest Capacity Factor?

(A) T1

(B) T2

(C) T3

(D) T4

Q.9

In the 4×4 array shown below, each cell of the first three columns has either a cross (X) or a number, as per the given rule.

1	1	2	
2	X	3	
2	X	4	
1	2	X	

Rule: The number in a cell represents the count of crosses around its immediate neighboring cells (left, right, top, bottom, diagonals).

As per this rule, the **maximum** number of crosses possible in the empty column is

(A) 0

(B) 1

(C) 2

(D) 3

Q.10	During a half-moon phase, the Earth-Moon-Sun form a right triangle. If the Moon-Earth-Sun angle at this half-moon phase is measured to be 89.85° , the ratio of the Earth-Sun and Earth-Moon distances is closest to
(A)	328
(B)	382
(C)	238
(D)	283

GATE 2024

Q.11 – Q.35 Carry ONE mark Each

Q.11	The first non-zero term in the Taylor series expansion of $(1 - x) - e^{-x}$ about $x = 0$ is
(A)	1
(B)	-1
(C)	$\frac{x^2}{2}$
(D)	$-\frac{x^2}{2}$
Q.12	Consider the normal probability distribution function $f(x) = \frac{4}{\sqrt{2\pi}} e^{-8(x+3)^2}$ <p>If μ and σ are the mean and standard deviation of $f(x)$ respectively, then the ordered pair (μ, σ) is</p>
(A)	$\left(3, \frac{1}{4}\right)$
(B)	$\left(-3, \frac{1}{4}\right)$
(C)	(3, 4)
(D)	(-3, 4)

Q.13	If $z_1 = -1 + i$ and $z_2 = 2i$, where $i = \sqrt{-1}$, then $\text{Arg}(z_1/z_2)$ is
(A)	$\frac{3\pi}{4}$
(B)	$\frac{\pi}{4}$
(C)	$\frac{\pi}{2}$
(D)	$\frac{\pi}{3}$

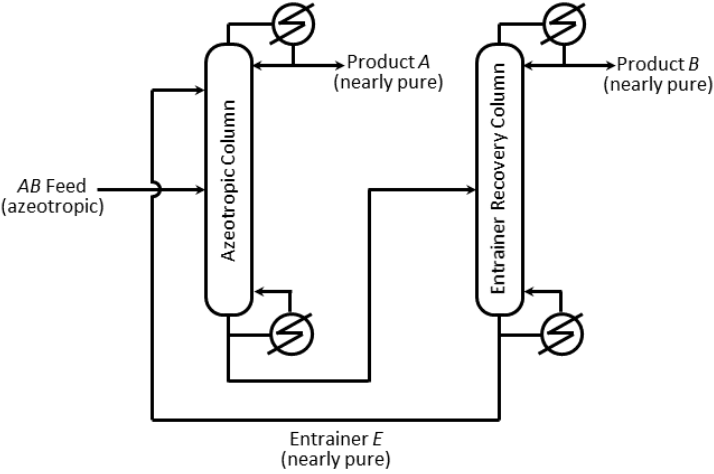
<p>Q.14</p>	<p>A homogeneous azeotropic distillation process separates an azeotropic AB binary feed using a heavy entrainer, E, as shown in the figure. The loss of E in the two product streams is negligible so that E circulates around the process in a closed-circuit. For a distillation column with fully specified feed(s), given operating pressure, a single distillate stream and a single bottoms stream, the steady-state degrees of freedom equals 2. For the process in the figure with a fully specified AB feed stream and given column operating pressures, the steady-state degrees of freedom equals</p>
	
<p>(A)</p>	<p>3</p>
<p>(B)</p>	<p>4</p>
<p>(C)</p>	<p>5</p>
<p>(D)</p>	<p>6</p>

Q.15	An infinitely long cylindrical water filament of radius R is surrounded by air. Assume water and air to be static. The pressure outside the filament is P_{out} and the pressure inside is P_{in} . If γ is the surface tension of the water-air interface, then $P_{\text{in}} - P_{\text{out}}$ is
(A)	$\frac{2\gamma}{R}$
(B)	0
(C)	$\frac{\gamma}{R}$
(D)	$\frac{4\gamma}{R}$
Q.16	The velocity field in an incompressible flow is $\mathbf{v} = \alpha xy \hat{\mathbf{i}} + v_y \hat{\mathbf{j}} + \beta \hat{\mathbf{k}}$, where $\hat{\mathbf{i}}$, $\hat{\mathbf{j}}$ and $\hat{\mathbf{k}}$ are unit-vectors in the (x, y, z) Cartesian coordinate system. Given that α and β are constants, and $v_y = 0$ at $y = 0$, the correct expression for v_y is
(A)	$\frac{-\alpha xy}{2}$
(B)	$\frac{-\alpha y^2}{2}$
(C)	$\frac{\alpha y^2}{2}$
(D)	$\frac{\alpha xy}{2}$

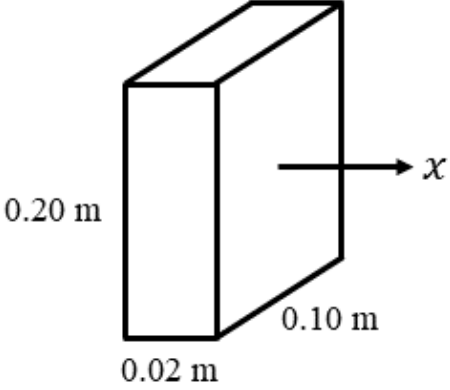
<p>Q.17</p>	<p>Consider the steady, uni-directional diffusion of a binary mixture of A and B across a vertical slab of dimensions $0.2 \text{ m} \times 0.1 \text{ m} \times 0.02 \text{ m}$ as shown in the figure. The total molar concentration of A and B is constant at 100 mol m^{-3}. The mole fraction of A on the left and right faces of the slab are maintained at 0.8 and 0.2, respectively. If the binary diffusion coefficient $D_{AB} = 1 \times 10^{-5} \text{ m}^2 \text{ s}^{-1}$, the molar flow rate of A in mol s^{-1}, along the horizontal x direction is</p>
	
<p>(A)</p>	<p>6×10^{-4}</p>
<p>(B)</p>	<p>6×10^{-6}</p>
<p>(C)</p>	<p>3×10^{-6}</p>
<p>(D)</p>	<p>3×10^{-4}</p>

Q.18	Consider a vapour-liquid mixture of components A and B that obeys Raoult's law. The vapour pressure of A is half that of B . The vapour phase concentrations of A and B are 3 mol m^{-3} and 6 mol m^{-3} , respectively. At equilibrium, the ratio of the liquid phase concentration of A to that of B is
(A)	1.0
(B)	0.5
(C)	2.0
(D)	1.5
Q.19	The ratio of the activation energy of a chemical reaction to the universal gas constant is 1000 K. The temperature-dependence of the reaction rate constant follows the collision theory. The ratio of the rate constant at 600 K to that at 400 K is
(A)	2.818
(B)	4.323
(C)	1.502
(D)	1.000

Q.20	The rate of a reaction $A \rightarrow B$ is $0.2 \text{ mol m}^{-3} \text{ s}^{-1}$ at a particular concentration C_{A1} . The rate constant of the reaction at a given temperature is $0.1 \text{ m}^3 \text{ mol}^{-1} \text{ s}^{-1}$. If the reactant concentration is increased to $10 C_{A1}$ at the same temperature, the reaction rate, in $\text{mol m}^{-3} \text{ s}^{-1}$, is
(A)	20
(B)	10
(C)	100
(D)	50
Q.21	Two parallel first-order liquid phase reactions $A \xrightarrow{k_1} B$ and $A \xrightarrow{k_2} C$ are carried out in a well-mixed isothermal batch reactor. The initial concentration of A in the reactor is 1 kmol m^{-3} , while that of B and C is zero. After 2 hours, the concentration of A reduces to half its initial value, and the concentration of B is twice that of C . The rate constants k_1 and k_2 , in h^{-1} , are, respectively
(A)	0.40, 0.20
(B)	0.23, 0.12
(C)	0.50, 0.25
(D)	0.36, 0.18

Q.22 Consider the block diagram in the figure with control input u , disturbance d and output y . For the feedforward controller, the ordered pair $(K, \alpha/\beta)$ is

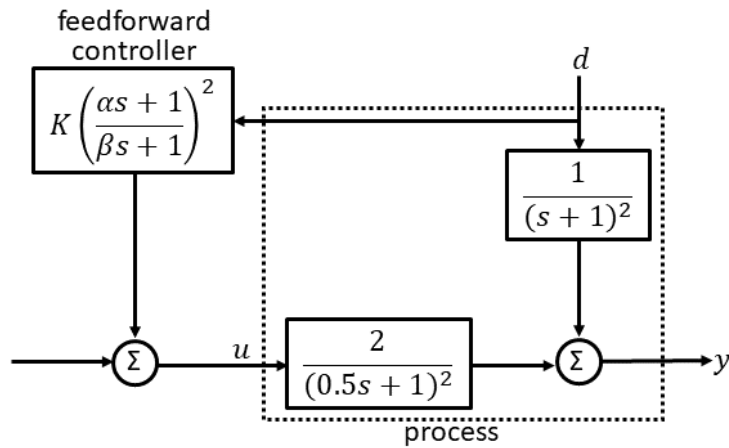

(A) (0.5, 2)

(B) (-0.5, 0.5)

(C) (-2, 2)

(D) (2, 0.5)

Q.23

Consider the control structure for the overhead section of a distillation column shown in the figure. The composition controller (CC) controls the heavy key impurity in the distillate by adjusting the setpoint of the reflux flow controller in a cascade arrangement. The sign of the controller gain for the pressure controller (PC) and that for the composition controller (CC) are, respectively,

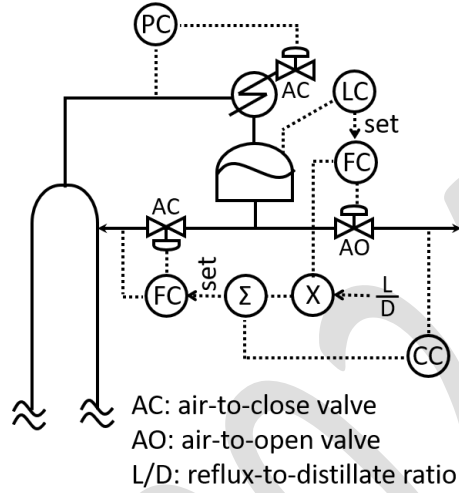

- (A) negative, negative
- (B) negative, positive
- (C) positive, positive
- (D) positive, negative

Q.24	Which one of the given statements is correct with reference to gas-liquid contactors for mass transfer applications?
(A)	A tray tower is more suitable for foaming systems than a packed tower.
(B)	Tray towers are preferred over packed towers for systems requiring frequent cleaning.
(C)	For a given liquid flow rate, the gas flow rate in the loading region is greater than that in the flooding region.
(D)	Flooding can never occur for counter-current contact.
Q.25	In an ammonia manufacturing facility, the necessary hydrogen is generated from methane. The facility consists of the following process units - P: Methanator, Q: CO shift convertor, R: CO ₂ stripper, S: Reformer, T: Ammonia convertor The correct order of these units, starting from methane feed is
(A)	S, Q, R, P, T
(B)	P, Q, R, S, T
(C)	S, P, Q, R, T
(D)	P, S, T, Q, R

Q.26	Consider a linear homogeneous system of equations $\mathbf{Ax} = \mathbf{0}$, where \mathbf{A} is an $n \times n$ matrix, \mathbf{x} is an $n \times 1$ vector and $\mathbf{0}$ is an $n \times 1$ null vector. Let r be the rank of \mathbf{A} . For a non-trivial solution to exist, which of the following conditions is/are satisfied?
(A)	Determinant of $\mathbf{A} = 0$
(B)	$r = n$
(C)	$r < n$
(D)	Determinant of $\mathbf{A} \neq 0$
Q.27	If the Prandtl number $Pr = 0.01$, which of the following statements is/are correct?
(A)	The momentum diffusivity is much larger than the thermal diffusivity.
(B)	The thickness of the momentum boundary layer is much smaller than that of the thermal boundary layer.
(C)	The thickness of the momentum boundary layer is much larger than that of the thermal boundary layer.
(D)	The momentum diffusivity is much smaller than the thermal diffusivity.

Q.28	For the electrolytic cell in a chlor-alkali plant, which of the following statements is/are correct?
(A)	A membrane cell operates at a higher brine concentration than a diaphragm cell.
(B)	Chlorine gas is produced at the cathode.
(C)	Hydrogen gas is produced at the cathode.
(D)	The caustic product stream exits the cathode compartment.
Q.29	Which of the following statements with reference to the petroleum/petrochemical industry is/are correct?
(A)	Catalytic hydrocracking converts heavier hydrocarbons to lighter hydrocarbons.
(B)	Catalytic reforming converts straight-chain hydrocarbons to aromatics.
(C)	Cumene is manufactured by the catalytic alkylation of benzene with propylene.
(D)	Vinyl acetate is manufactured by reacting methane with acetic acid over a palladium catalyst.

Q.30	Consider a matrix $\mathbf{A} = \begin{bmatrix} -5 & a \\ -2 & -2 \end{bmatrix}$, where a is a constant. If the eigenvalues of \mathbf{A} are -1 and -6 , then the value of a , rounded off to the nearest integer, is _____
Q.31	Consider the reaction $N_2(g) + 3H_2(g) \rightleftharpoons 2NH_3(g)$ in a continuous flow reactor under steady-state conditions. The component flow rates at the reactor inlet are $F_{N_2}^0 = 100 \text{ mol s}^{-1}$, $F_{H_2}^0 = 300 \text{ mol s}^{-1}$, $F_{\text{inert}}^0 = 1 \text{ mol s}^{-1}$. If the fractional conversion of H_2 is 0.60, the outlet flow rate of N_2 , in mol s^{-1} , rounded off to the nearest integer, is _____
Q.32	<p>Consider a binary mixture of components A and B at temperature T and pressure P. Let \bar{V}_A and \bar{V}_B be the partial molar volumes of A and B, respectively. At a certain mole fraction of A, x_A</p> $\left(\frac{\partial \bar{V}_A}{\partial x_A}\right)_{T,P} = 22 \text{ cm}^3 \text{ mol}^{-1} \quad \text{and} \quad \left(\frac{\partial \bar{V}_B}{\partial x_A}\right)_{T,P} = -18 \text{ cm}^3 \text{ mol}^{-1}$ <p>The value of x_A, rounded off to 2 decimal places, is _____</p>
Q.33	Consider the steady, uni-directional, fully-developed, pressure-driven laminar flow of an incompressible Newtonian fluid through a circular pipe of inner radius 5.0 cm. The magnitude of shear stress at the inner wall of the pipe is 0.1 N m^{-2} . At a radial distance of 1.0 cm from the pipe axis, the magnitude of the shear stress, in N m^{-2} , rounded off to 3 decimal places, is _____
Q.34	The opposite faces of a metal slab of thickness 5 cm and thermal conductivity $400 \text{ W m}^{-1} \text{ }^\circ\text{C}^{-1}$ are maintained at $500 \text{ }^\circ\text{C}$ and $200 \text{ }^\circ\text{C}$. The area of each face is 0.02 m^2 . Assume that the heat transfer is steady and occurs only in the direction perpendicular to the faces. The magnitude of the heat transfer rate, in kW, rounded off to the nearest integer, is _____

Q.35	The capital cost of a distillation column is Rs. 90 lakhs. The cost is to be fully depreciated (salvage value is zero) using the double-declining balance method over 10 years. At the end of two years of continuous operation, the book-value of the column, in lakhs of rupees, rounded off to 1 decimal place, is _____

GATE 2024

Q.36 – Q.65 Carry TWO marks Each

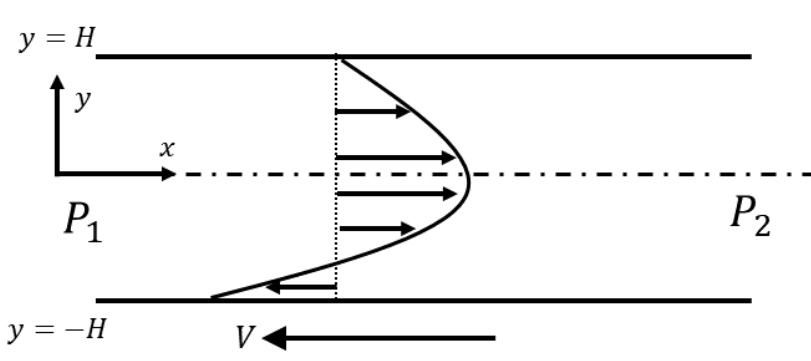
<p>Q.36</p>	<p>Consider a steady, fully-developed, uni-directional laminar flow of an incompressible Newtonian fluid (viscosity μ) between two infinitely long horizontal plates separated by a distance $2H$ as shown in the figure. The flow is driven by the combined action of a pressure gradient and the motion of the bottom plate at $y = -H$ in the negative x direction. Given that $\frac{\Delta P}{L} = \frac{(P_1 - P_2)}{L} > 0$, where P_1 and P_2 are the pressures at two x locations separated by a distance L. The bottom plate has a velocity of magnitude V with respect to the stationary top plate at $y = H$. Which one of the following represents the x-component of the fluid velocity vector?</p>
	
<p>(A)</p>	$\frac{\Delta P}{L} \frac{H^2}{2\mu} \left(1 - \frac{y^2}{H^2} \right) + \frac{V}{2} \left(\frac{y}{H} - 1 \right)$
<p>(B)</p>	$\frac{\Delta P}{L} \frac{H^2}{2\mu} \left(\frac{y^2}{H^2} - 1 \right) + \frac{V}{2} \left(\frac{y}{H} - 1 \right)$
<p>(C)</p>	$\frac{\Delta P}{L} \frac{H^2}{2\mu} \left(\frac{y^2}{H^2} - 1 \right) - \frac{V}{2} \left(\frac{y}{H} - 1 \right)$
<p>(D)</p>	$\frac{\Delta P}{L} \frac{H^2}{2\mu} \left(1 - \frac{y^2}{H^2} \right) - \frac{V}{2} \left(\frac{y}{H} - 1 \right)$

Q.37	The temperatures of two large parallel plates of equal emissivity are 900 K and 300 K. A reflection radiation shield of low emissivity and negligible conductive resistance is placed parallelly between them. The steady-state temperature of the shield, in K, is
(A)	759
(B)	559
(C)	659
(D)	859
Q.38	Hot oil at 110 °C heats water from 30 °C to 70 °C in a counter-current double-pipe heat exchanger. The flow rates of water and oil are 50 kg min ⁻¹ and 100 kg min ⁻¹ , respectively and their specific heat capacities are 4.2 kJ kg ⁻¹ °C ⁻¹ and 2.0 kJ kg ⁻¹ °C ⁻¹ , respectively. Assume the heat exchanger is at steady state. If the overall heat transfer coefficient is 200 W m ⁻² °C ⁻¹ , the heat transfer area in m ² is
(A)	17.9
(B)	1.1
(C)	5.2
(D)	35.2

Q. 39	A solid slab of thickness H_1 is initially at a uniform temperature T_0 . At time $t = 0$, the temperature of the top surface at $y = H_1$ is increased to T_1 , while the bottom surface at $y = 0$ is maintained at T_0 for $t \geq 0$. Assume heat transfer occurs only in the y -direction, and all thermal properties of the slab are constant. The time required for the temperature at $y = H_1/2$ to reach 99% of its final steady value is τ_1 . If the thickness of the slab is doubled to $H_2 = 2H_1$, and the time required for the temperature at $y = H_2/2$ to reach 99% of its final steady value is τ_2 , then τ_2/τ_1 is
(A)	2
(B)	$\frac{1}{4}$
(C)	4
(D)	$\frac{1}{2}$

Q.40	A gas stream containing 95 mol% CO ₂ and 5 mol% ethanol is to be scrubbed with pure water in a counter-current, isothermal absorption column to remove ethanol. The desired composition of ethanol in the exit gas stream is 0.5 mol%. The equilibrium mole fraction of ethanol in the gas phase, y^* , is related to that in the liquid phase, x , as $y^* = 2x$. Assume CO ₂ is insoluble in water and neglect evaporation of water. If the water flow rate is twice the minimum, the mole fraction of ethanol in the spent water is
(A)	0.0225
(B)	0.0126
(C)	0.0428
(D)	0.0316
Q.41	Sulfur dioxide (SO ₂) gas diffuses through a stagnant air-film of thickness 2 mm at 1 bar and 30 °C. The diffusion coefficient of SO ₂ in air is $1 \times 10^{-5} \text{ m}^2 \text{ s}^{-1}$. The SO ₂ partial pressures at the opposite sides of the film are 0.15 bar and 0.05 bar. The universal gas constant is $8.314 \text{ J mol}^{-1} \text{ K}^{-1}$. Assuming ideal gas behavior, the steady-state flux of SO ₂ in $\text{mol m}^{-2} \text{ s}^{-1}$ through the air-film is
(A)	0.077
(B)	0.022
(C)	0.085
(D)	0.057

Q.42	A simple distillation column separates a binary mixture of A and B . The relative volatility of A with respect to B is 2. The steady-state composition of A in the vapour leaving the 1 st , 2 nd and 3 rd trays in the rectifying section are 94, 90 and 85 mol%, respectively. For ideal trays and constant molal overflow, the reflux-to-distillate ratio is
(A)	1.9
(B)	2.7
(C)	1.2
(D)	1.1
Q.43	Alumina particles with an initial moisture content of 5 kg per kg dry solid are dried in a batch dryer. For the first two hours, the measured drying rate is constant at $2 \text{ kg m}^{-2} \text{ h}^{-1}$. Thereafter, in the falling-rate period, the rate decreases linearly with the moisture content. The equilibrium moisture content is 0.05 kg per kg dry solid and the drying area of the particles is 0.5 m^2 per kg dry solid. The total drying time, in h, to reduce the moisture content to half its initial value is
(A)	4.13
(B)	2.55
(C)	3.22
(D)	5.13

Q.44	A first-order heterogenous reaction $A \rightarrow B$ is carried out using a porous spherical catalyst. Assume isothermal conditions, and that intraphase diffusion controls the reaction rate. At a bulk A concentration of 0.3 mol L^{-1} , the observed reaction rate in a 3 mm diameter catalyst particle is $0.2 \text{ mol s}^{-1} \text{ L}^{-1}$ catalyst volume. At a bulk A concentration of 0.1 mol L^{-1} , the observed reaction rate, in $\text{mol s}^{-1} \text{ L}^{-1}$ catalyst volume, in a 6 mm diameter catalyst particle, is
(A)	0.011
(B)	0.033
(C)	0.022
(D)	0.005
Q.45	A first-order liquid phase reaction $A \rightarrow B$ is carried out in two isothermal plug flow reactors (PFRs) of volume 1 m^3 each, connected in series. The feed flow rate and concentration of A to the first reactor are $10 \text{ m}^3 \text{ h}^{-1}$ and 1 kmol m^{-3} , respectively. At steady-state, the concentration of A at the exit of the second reactor is 0.2 kmol m^{-3} . If the two PFRs are replaced by two equal-volume continuously stirred tank reactors (CSTRs) to achieve the same overall steady-state conversion, the volume of each CSTR, in m^3 , is
(A)	1.54
(B)	3.84
(C)	7.28
(D)	1.98

Q.46

The residence time distribution, E , for a non-ideal flow reactor is given in the figure. A first-order liquid phase reaction with a rate constant 0.2 min^{-1} is carried out in the reactor. For an inlet reactant concentration of 2 mol L^{-1} , the reactant concentration (in mol L^{-1}) in the exit stream is

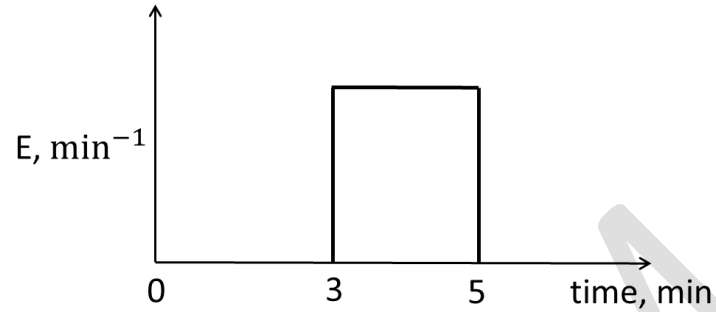

(A) 0.905

(B) 0.452

(C) 1.902

(D) 0.502

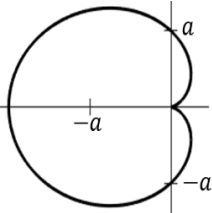
Q.47	<p>Let r and θ be the polar coordinates defined by $x = r \cos \theta$ and $y = r \sin \theta$. The area of the cardioid $r = a(1 - \cos \theta)$, $0 \leq \theta \leq 2\pi$, is</p> 
(A)	$\frac{3\pi a^2}{2}$
(B)	$\frac{2\pi a^2}{3}$
(C)	$3\pi a^2$
(D)	$2\pi a^2$

Q.48 For the block diagram shown in the figure, the correct expression for the transfer function $G_d = \frac{y_1(s)}{d(s)}$ is

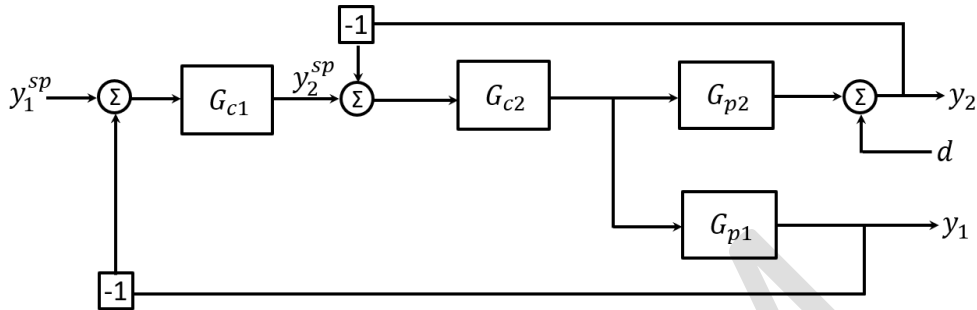

(A)
$$\frac{-G_{p1}G_{c2}}{(1 + G_{c1}G_{c2}G_{p1})(1 + G_{c2}G_{p2})}$$

(B)
$$\frac{-G_{p1}G_{c2}}{1 + G_{c2}G_{p2} + G_{c1}G_{c2}G_{p1}G_{p2}}$$

(C)
$$\frac{-G_{p1}G_{c2}}{1 + G_{c2}G_{p2} + G_{c1}G_{c2}G_{p1}}$$

(D)
$$\frac{1}{1 + G_{c2}G_{p2} + G_{c1}G_{c2}G_{p1}G_{p2}}$$

Q.49	For purchasing a batch reactor, three alternatives P, Q and R have emerged, as summarized in the table. For a compound interest rate of 10% per annum, choose the correct option that arranges the alternatives, in order, from the least expensive to the most expensive.																
	<table border="1" data-bbox="539 443 1166 837"> <thead> <tr> <th></th> <th>P</th> <th>Q</th> <th>R</th> </tr> </thead> <tbody> <tr> <td>Installed Cost (lakh rupees)</td> <td>15</td> <td>25</td> <td>35</td> </tr> <tr> <td>Equipment Life (years)</td> <td>3</td> <td>5</td> <td>7</td> </tr> <tr> <td>Maintenance Cost (lakh rupees per year)</td> <td>4</td> <td>3</td> <td>2</td> </tr> </tbody> </table>		P	Q	R	Installed Cost (lakh rupees)	15	25	35	Equipment Life (years)	3	5	7	Maintenance Cost (lakh rupees per year)	4	3	2
	P	Q	R														
Installed Cost (lakh rupees)	15	25	35														
Equipment Life (years)	3	5	7														
Maintenance Cost (lakh rupees per year)	4	3	2														
(A)	P, Q, R																
(B)	R, P, Q																
(C)	R, Q, P																
(D)	Q, R, P																
Q.50	<p>The Newton-Raphson method is used to solve $f(x) = 0$, where $f(x) = e^x - 5x$.</p> <p>If the initial guess $x^{(0)} = 1.0$, the value of the next iterate, $x^{(1)}$, rounded off to 2 decimal places, is _____</p>																
Q.51	<p>Consider the line integral $\int_C \mathbf{F}(\mathbf{r}) \cdot d\mathbf{r}$, with $\mathbf{F}(\mathbf{r}) = x \hat{\mathbf{i}} + y \hat{\mathbf{j}} + z \hat{\mathbf{k}}$, where $\hat{\mathbf{i}}$, $\hat{\mathbf{j}}$ and $\hat{\mathbf{k}}$ are unit vectors in the (x, y, z) Cartesian coordinate system. The path C is given by $\mathbf{r}(t) = \cos(t) \hat{\mathbf{i}} + \sin(t) \hat{\mathbf{j}} + t \hat{\mathbf{k}}$, where $0 \leq t \leq \pi$. The value of the integral, rounded off to 2 decimal places, is _____</p>																

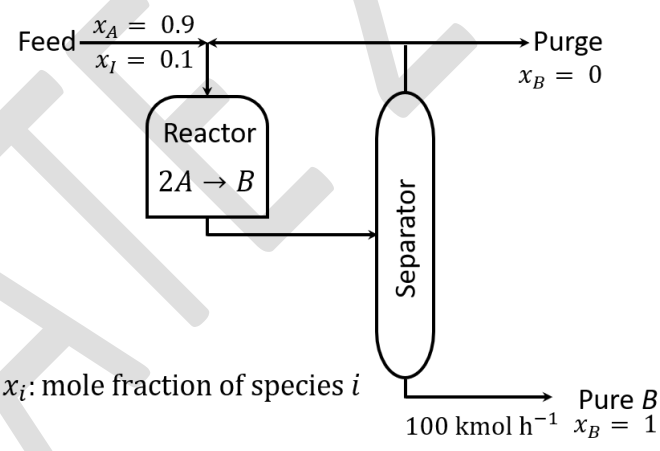
<p>Q.52</p>	<p>Consider the ordinary differential equation $x^2 \frac{d^2y}{dx^2} - x \frac{dy}{dx} - 3y = 0$, with the boundary conditions $y(x = 1) = 2$ and $y(x = 2) = 17/2$. The solution $y(x)$ at $x = 3/2$, rounded off to 2 decimal places, is _____</p>
<p>Q.53</p>	<p>Consider the function $f(x, y, z) = x^4 + 2y^3 + z^2$. The directional derivative of the function at the point $P(-1, 1, -1)$ along $(\hat{i} + \hat{j})$, where \hat{i} and \hat{j} are unit vectors in the x and y directions, respectively, rounded off to 2 decimal places, is _____</p>
<p>Q.54</p>	<p>Consider the process in the figure for manufacturing B. The feed to the process is 90 mol% A and a close-boiling inert component I. At a particular steady-state:</p> <ul style="list-style-type: none"> • B product rate is 100 kmol h^{-1} • Single-pass conversion of A in the reactor is 50% • Recycle-to-purge stream flow ratio is 10 <p>The flow rate of A in the purge stream in kmol h^{-1}, rounded off to 1 decimal place, is _____</p>  <p style="text-align: center;">x_i: mole fraction of species i</p>

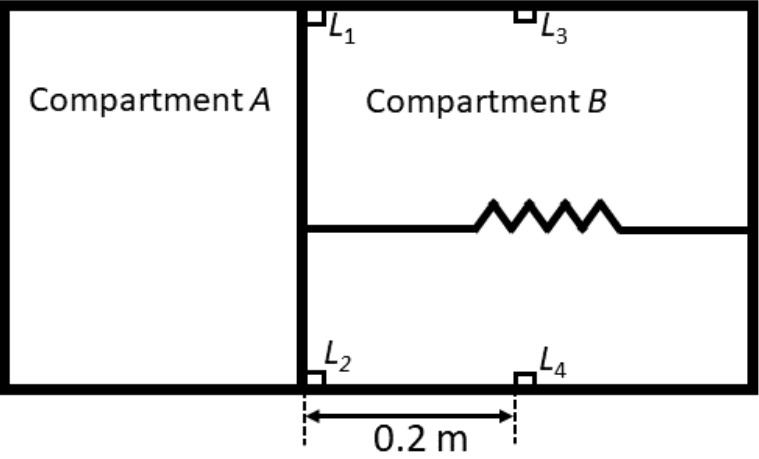
<p>Q.55</p>	<p>Methane combusts with air in a furnace as $CH_4 + 2O_2 \rightarrow CO_2 + 2H_2O$. The heat of reaction $\Delta H_{rxn} = -880$ kJ per mol CH_4 and is assumed to be constant. The furnace is well-insulated and no other side reactions occur. All components behave as ideal gases with a constant molar heat capacity of $44 \text{ J mol}^{-1} \text{ }^\circ\text{C}^{-1}$. Air may be considered as 20 mol% O_2 and 80 mol% N_2. The air-fuel mixture enters the furnace at $50 \text{ }^\circ\text{C}$. The methane conversion X varies with the air-to-methane mole ratio, r, as</p> $X = 1 - 0.1 e^{-2(r-r_s)} \quad \text{with} \quad 0.9 r_s \leq r \leq 1.1 r_s$ <p>where r_s is the stoichiometric air-to-methane mole ratio. For $r = 1.05 r_s$, the exit flue gas temperature in $^\circ\text{C}$, rounded off to 1 decimal place, is _____</p>
<p>Q.56</p>	<p>An isolated system consists of two perfectly sealed cuboidal compartments A and B separated by a movable rigid wall of cross-sectional area 0.1 m^2 as shown in the figure. Initially, the movable wall is held in place by latches L_1 and L_2 such that the volume of compartment A is 0.1 m^3. Compartment A contains a monoatomic ideal gas at 5 bar and 400 K. Compartment B is perfectly evacuated and contains a massless Hookean spring of force constant 0.3 N m^{-1} at its equilibrium length (stored elastic energy is zero). The latches L_1 and L_2 are released, the wall moves to the right by 0.2 m, where it is held at the new position by latches L_3 and L_4. Assume all the walls and latches are massless. The final equilibrium temperature, in K, of the gas in compartment A, rounded off to 1 decimal place, is _____</p>
	

<p>Q.57</p>	<p>Ethylene obeys the truncated virial equation-of-state</p> $\frac{PV}{RT} = 1 + \frac{BP}{RT}$ <p>where P is the pressure, V is the molar volume, T is the absolute temperature and B is the second virial coefficient. The universal gas constant $R = 83.14 \text{ bar cm}^3 \text{ mol}^{-1}\text{K}^{-1}$. At 340 K, the slope of the compressibility factor vs. pressure curve is $-3.538 \times 10^{-3} \text{ bar}^{-1}$. Let G^R denote the molar residual Gibbs free energy. At these conditions, the value of $\left(\frac{\partial G^R}{\partial P}\right)_T$, in $\text{cm}^3 \text{ mol}^{-1}$, rounded off to 1 decimal place, is _____</p>
<p>Q.58</p>	<p>A metallic spherical particle of density 7001 kg m^{-3} and diameter 1 mm is settling steadily due to gravity in a stagnant gas of density 1 kg m^{-3} and viscosity $10^{-5} \text{ kg m}^{-1} \text{ s}^{-1}$. Take $g = 9.8 \text{ m s}^{-2}$. Assume that the settling occurs in the regime where the drag coefficient C_D is independent of the Reynolds number, and equals 0.44. The terminal settling velocity of the particle, in m s^{-1}, rounded off to 2 decimal places, is _____</p>

Q.59 Water of density 1000 kg m^{-3} is pumped at a volumetric flow rate of $3.14 \times 10^{-2} \text{ m}^3 \text{ s}^{-1}$, through a pipe of inner diameter 10 cm and length 100 m, from a large Reservoir 1 to another large Reservoir 2 at a height 50 m above Reservoir 1, as shown in the figure. The flow in the pipe is in the turbulent regime with a Darcy friction factor $f = 0.06$, and a kinetic energy correction factor $\alpha = 1$. Take $g = 9.8 \text{ m s}^{-2}$. If all minor losses are negligible, and the pump efficiency is 100%, the pump power, in kW, rounded off to 2 decimal places, is _____

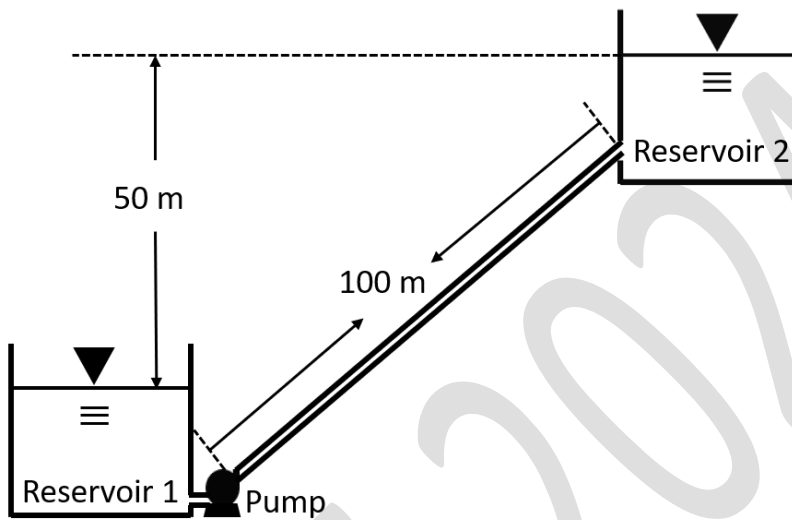

Q.60 A Venturi meter with a throat diameter $d = 2 \text{ cm}$ measures the flow rate in a pipe of diameter $D = 6 \text{ cm}$, as shown in the figure. A U-tube manometer is connected to measure the pressure drop. Assume the discharge coefficient is independent of the Reynolds number and geometric ratios. If the volumetric flow rate through the pipe is doubled $Q_2 = 2Q_1$, the corresponding ratio of the manometer readings $\Delta h_2/\Delta h_1$, rounded off to the nearest integer, is _____

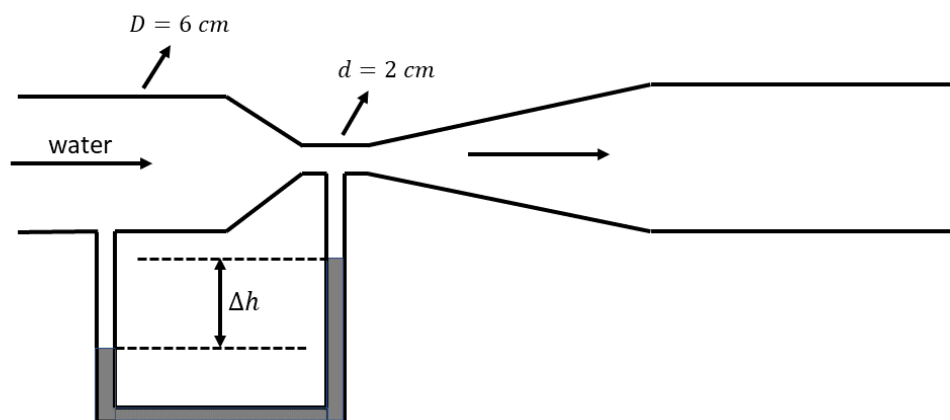

Q.61 Heat is available at a rate of 2 kW from a thermal reservoir at 400 K. A two-stage process harnesses this heat to produce power. Stages 1 and 2 reject heat at 360 K and 300 K, respectively. Stage 2 is driven by the heat rejected by Stage 1. If the overall process efficiency is 50% of the corresponding Carnot efficiency, the power delivered by the process, in kW, rounded off to 2 decimal places, is _____

Q.62 A chemostat with cell recycle is shown in the figure. The feed flow rate and culture volume are $F = 75 \text{ L h}^{-1}$ and $V = 200 \text{ L}$, respectively. The glucose concentration in the feed $C_{S0} = 15 \text{ g L}^{-1}$. Assume Monod kinetics with specific cell growth rate $\mu_g = \frac{1}{C_C} \frac{dC_C}{dt} = \frac{\mu_m C_S}{K_S + C_S}$, where $\mu_m = 0.25 \text{ h}^{-1}$ and $K_S = 1 \text{ g L}^{-1}$. Assume maintenance and death rates to be zero, input feed to be sterile ($C_{C0} = 0$) and steady-state operation. The glucose concentration in the recycle stream, C_{S1} , in g L^{-1} , rounded off to 1 decimal place, is _____

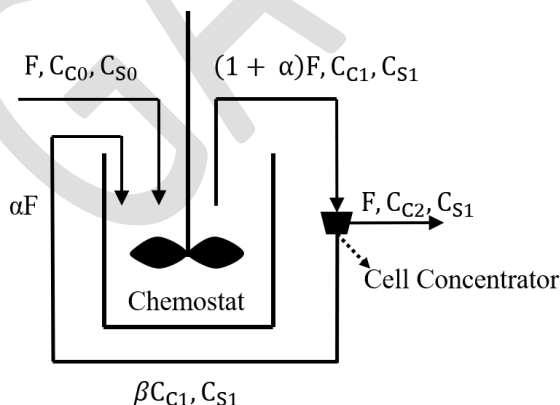

F : Volumetric flow rate
 C_C : Cell concentration
 C_S : Substrate (glucose) concentration
 α : Recycle ratio ($\alpha = 0.5$)
 β : Concentration factor ($\beta = 2.0$)

Q.63 Consider the surge drum in the figure. Initially the system is at steady-state with a hold-up $\bar{V} = 5 \text{ m}^3$, which is 50% of full tank capacity, V_{full} , and volumetric flow rates $\bar{F}_{in} = \bar{F}_{out} = 1 \text{ m}^3 \text{ h}^{-1}$. The high hold-up alarm limit $V_{high} = 0.8 V_{full}$ while the low hold-up alarm limit $V_{low} = 0.2 V_{full}$. A proportional (P-only) controller manipulates the outflow to regulate the hold-up V as $F_{out} = K_c(V - \bar{V}) + \bar{F}_{out}$. At $t = 0$, F_{in} increases as a step from $1 \text{ m}^3 \text{ h}^{-1}$ to $2 \text{ m}^3 \text{ h}^{-1}$. Assume linear control valves and instantaneous valve dynamics. Let K_c^{min} be the minimum controller gain that ensures V never exceeds V_{high} . The value of K_c^{min} , in h^{-1} , rounded off to 2 decimal places, is _____

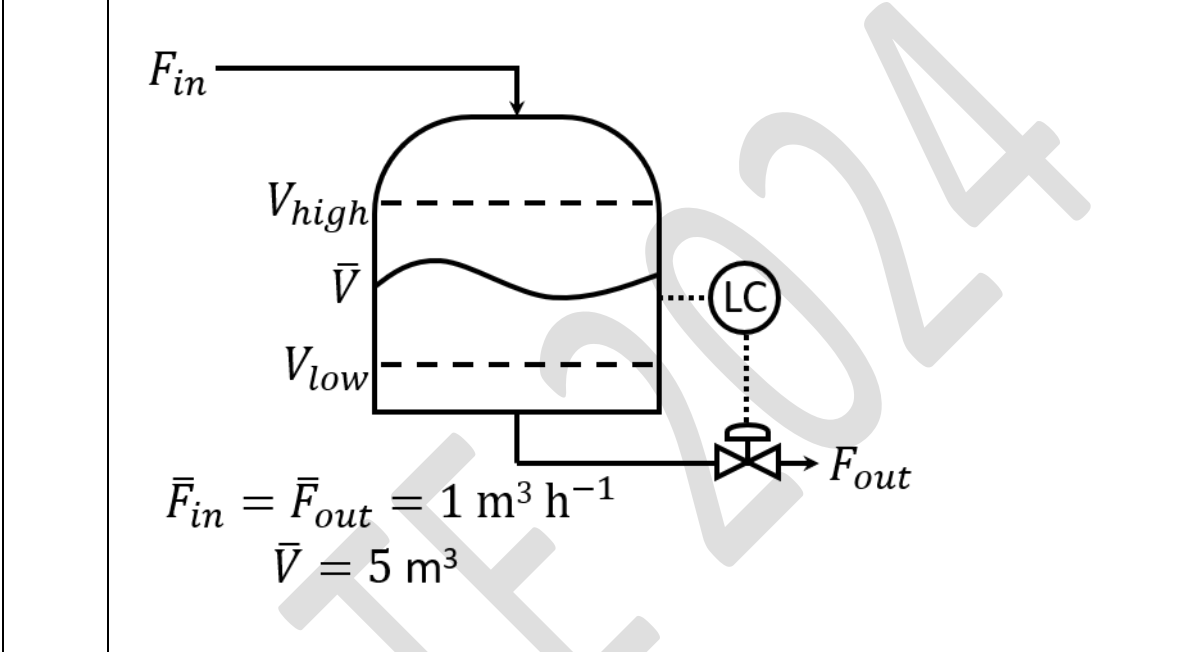

Q. 64 A PD controller with transfer function G_c is used to stabilize an open-loop unstable process with transfer function G_p , where

$$G_c = K_c \frac{\tau_D s + 1}{\left(\frac{\tau_D}{20}\right) s + 1}, G_p = \frac{1}{(s - 1)(10s + 1)}$$

and time is in minutes. From the necessary conditions for closed-loop stability, the maximum feasible value of τ_D , in minutes, rounded off to 1 decimal place, is _____

Q.65 Consider a tray-column of diameter 120 cm. Each downcomer has a cross-sectional area of 575 cm^2 . For a tray, the percentage column cross-sectional area not available for vapour flow due to the downcomers, rounded off to 1 decimal place, is _____



GRADUATE APTITUDE TEST IN ENGINEERING 2024

अभियांत्रिकी स्नातक अभिक्षमता परीक्षा २०२४

ORGANISING INSTITUTE: INDIAN INSTITUTE OF SCIENCE, BENGALURU



Chemical Engineering (CH) Master Answer Key

Q. No.	Session	Question Type	Section	Key/Range	Mark
1	3	MCQ	GA	B	1
2	3	MCQ	GA	A	1
3	3	MCQ	GA	A	1
4	3	MCQ	GA	D	1
5	3	MCQ	GA	C	1
6	3	MCQ	GA	D	2
7	3	MCQ	GA	A	2
8	3	MCQ	GA	A	2
9	3	MCQ	GA	C	2
10	3	MCQ	GA	B	2
11	3	MCQ	CH	D	1
12	3	MCQ	CH	B	1
13	3	MCQ	CH	B	1
14	3	MCQ	CH	C	1
15	3	MCQ	CH	C	1
16	3	MCQ	CH	B	1
17	3	MCQ	CH	A	1
18	3	MCQ	CH	A	1
19	3	MCQ	CH	A	1
20	3	MCQ	CH	A	1
21	3	MCQ	CH	B	1
22	3	MCQ	CH	B	1
23	3	MCQ	CH	D	1
24	3	MCQ	CH	B	1
25	3	MCQ	CH	A	1
26	3	MSQ	CH	A;C	1
27	3	MSQ	CH	B;D	1
28	3	MSQ	CH	A;C;D	1
29	3	MSQ	CH	A;B;C	1

30	3	NAT	CH	-2 to -2	1
31	3	NAT	CH	40 to 40	1
32	3	NAT	CH	0.44 to 0.46	1
33	3	NAT	CH	0.019 to 0.021	1
34	3	NAT	CH	48 to 48	1
35	3	NAT	CH	57.5 to 57.7	1
36	3	MCQ	CH	A	2
37	3	MCQ	CH	A	2
38	3	MCQ	CH	A	2
39	3	MCQ	CH	C	2
40	3	MCQ	CH	B	2
41	3	MCQ	CH	B	2
42	3	MCQ	CH	B	2
43	3	MCQ	CH	B	2
44	3	MCQ	CH	B	2
45	3	MCQ	CH	A	2
46	3	MCQ	CH	A	2
47	3	MCQ	CH	A	2
48	3	MCQ	CH	C	2
49	3	MCQ	CH	C	2
50	3	NAT	CH	-0.01 to 0.01	2
51	3	NAT	CH	4.91 to 4.95	2
52	3	NAT	CH	4.00 to 4.08	2
53	3	NAT	CH	1.39 to 1.43	2
54	3	NAT	CH	18.1 to 18.3	2
55	3	NAT	CH	1720.0 to 1730.0	2
56	3	NAT	CH	396.6 to 397.0	2
57	3	NAT	CH	-101.0 to -99.0	2
58	3	NAT	CH	14.40 to 14.60	2
59	3	NAT	CH	30.40 to 30.50	2
60	3	NAT	CH	4 to 4	2
61	3	NAT	CH	0.24 to 0.26	2
62	3	NAT	CH	2.9 to 3.1	2
63	3	NAT	CH	0.32 to 0.34	2
64	3	NAT	CH	22.1 to 22.3	2
65	3	NAT	CH	10.0 to 10.3	2