

CAREERS 360 **PREPARATION** Series

Past 5 Years UCEED

Question papers with solution (2019 – 2023)

UCEED 2023 - ANSWER KEY

SECTION – A (NAT)									
Q. No.	KEY RANGE	Q. No.	KEY RANGE	Q. No.	KEY RANGE	Q. No.	KEY RANGE	Q. No.	KEY RANGE
01	4	02	132.8 - 133.1	03	6	04	5	05	27
06	30	07	6	08	46	09	9	10	11
11	81	12	20.5 – 21.5	13	5.9 – 6.1	14	20	15	0.17 - 0.19
16	23	17	21	18	10				

SECTION – B (MSQ)									
Q.No.	KEYS	Q.No.	KEYS	Q.No.	KEYS	Q.No.	KEYS	Q.No.	KEYS
19	A,B,C	20	A,D	21	A,D	22	A,B,D	23	A,C
24	A,B,C	25	A,D	26	B,C,D	27	A,B,D	28	A,B,D
29	A,C	30	A,D	31	B,C,D	32	C,D	33	B,C
34	A,B	35	B,C	36	C,D				

SECTION – C (MCQ)									
Q.No.	KEY	Q.No.	KEY	Q.No.	KEY	Q.No.	KEY	Q.No.	KEY
37	C	38	B	39	A	40	C	41	C
42	D	43	B	44	A	45	B	46	B
47	D	48	D	49	D	50	C	51	B
52	B	53	B	54	B	55	C	56	C
57	D	58	C	59	D	60	D	61	B
62	A	63	C	64	B	65	C	66	A
67	C	68	A						

Undergraduate Common Entrance Examination for Design

UCEED 2023

Paper Specific Instructions

- The total duration of the examination is 3 hours. The question paper contains two parts – Part A and Part B. The duration of Part A is **2 hours and 30 minutes**. Part B will begin after Part A ends. Part A is further divided into three sections, 1, 2 and 3. All sections are compulsory. Questions in each section are of different types. There are a total of **68 questions** carrying a total of 240 marks. Questions of Part A will appear on the computer. Answers to **Part A** have to be entered in the **computer**. **Part B** is also compulsory and contains **1 drawing question** of 60 marks.
- Marking scheme of Part A is as follows:

Section	Type of questions	Number of questions	Marks for correct answer	Marks for wrong answer	Marks for each question not attempted	Total marks for the section
1	NAT	18	4	0	0	72
2	MSQ	18	Partial Marking	-1	0	72
3	MCQ	32	3	-0.71	0	96
Total		68				240

- Section 1 (72 Marks)** of Part A contains a total of 18 **Numerical Answer Type (NAT)** questions. For each question, the answer is a **real number with decimal digits upto two decimal places** that needs to be entered using the virtual keyboard on the monitor. No choices will be shown for these questions. There is **NO NEGATIVE** marking for this section. Questions from 1 to 18 belong to this section.
- Section 2 (72 Marks)** of Part A contains a total of 18 **Multiple Select Questions (MSQ)**. Each question may have **one or more than one correct choice(s)** out of the four given. The following is the marking scheme:

Full Marks : + 4 If only (all) the correct option(s) is(are) chosen and NONE of the incorrect options is chosen.

Partial Marks : + 3 If all the four options are correct but ONLY three options are chosen and NONE of the incorrect options is chosen.

Partial Marks : + 2 If three or more options are correct but ONLY two options are chosen, both of which are correct and NONE of the incorrect options is chosen.

Partial Marks : + 1 If two or more options are correct but ONLY one option is chosen and it is the correct option and NONE of the incorrect options is chosen.

Zero Marks : 0 If NONE of the options is chosen (i.e., the question is unanswered);

Negative Marks: -1 In all other cases.

Questions from 19 to 36 belong to this section.

5. **Section 3 (96 Marks)** of Part A contains a total of 32 **Multiple Choice Questions (MCQ)**. Each question has four choices out of which **ONLY ONE** is the correct answer. There is **NEGATIVE** marking for this section. Questions from 37 to 68 belong to this section.
6. **Part B (60 Marks)** contains one drawing question. There is **NO NEGATIVE** marking for this section. Answers to **Part B** have to be given in the **answer book** provided by the invigilator. Question 69 belongs to this section.
7. Calculators, charts, graph-sheets, mathematical tables, mobile phone, smart watches and/or other electronic gadgets are **NOT** allowed in the examination hall.
8. Scribble pad/blank sheets of paper will be provided for rough work.

PART A

Section 1: Numerical Answer Type (NAT)

questions

Section 1 (72 Marks) of Part A contains a total of 18 **Numerical Answer Type (NAT)** questions. For each question, the answer is a real number that needs to be entered using the virtual keyboard on the monitor. No choices will be shown for these questions. There is **NO NEGATIVE** marking for this section. Each correct answer will be awarded 4 marks. Questions that are not attempted or answered incorrectly will be given zero mark. Questions from 1 to 18 belong to this section.

Q.01 How many times does the shape sequence (shown on the top) appear in the grid below? The sequence may appear top-to-bottom, bottom-to-top, left-to-right, right-to-left or at an angle.



▶	●	▲	■	⬡	●
★	⬡	▶	★	▶	★
⬡	●	■	▲	▶	⬡
■	■	▶	★	●	●
▶	▲	★	■	▶	★
●	★	▲	■	●	⬡

Q.02 The bold lines correspond to four different paths P, Q, R and S. What is the length of the longest path? The length of each side of the square grids is 7 units. Use $\frac{22}{7}$ as the value for π .

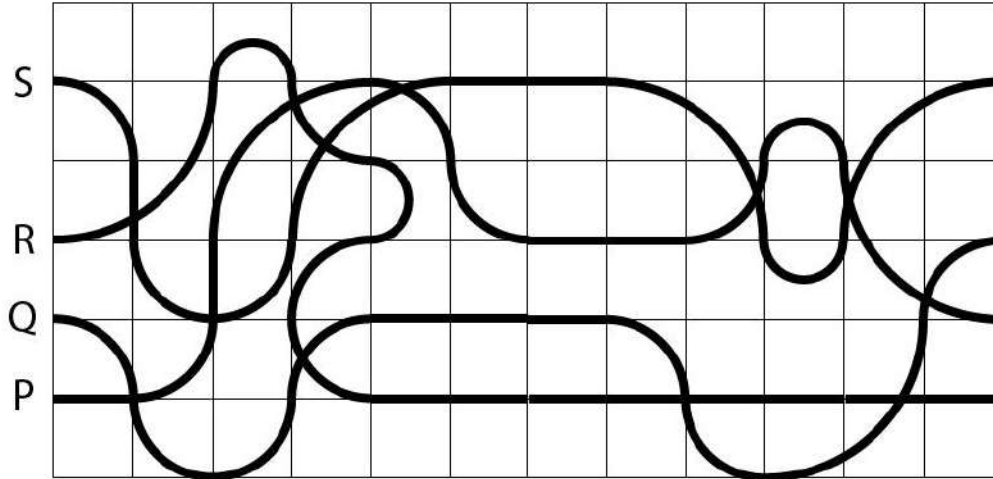

Q.03 What is the maximum number of stars that can be packed inside the blue colour boundary including the one that is shown in the image below? The stars can be scaled but should not overlap. At least 4 points of every star should touch the blue colour boundary.

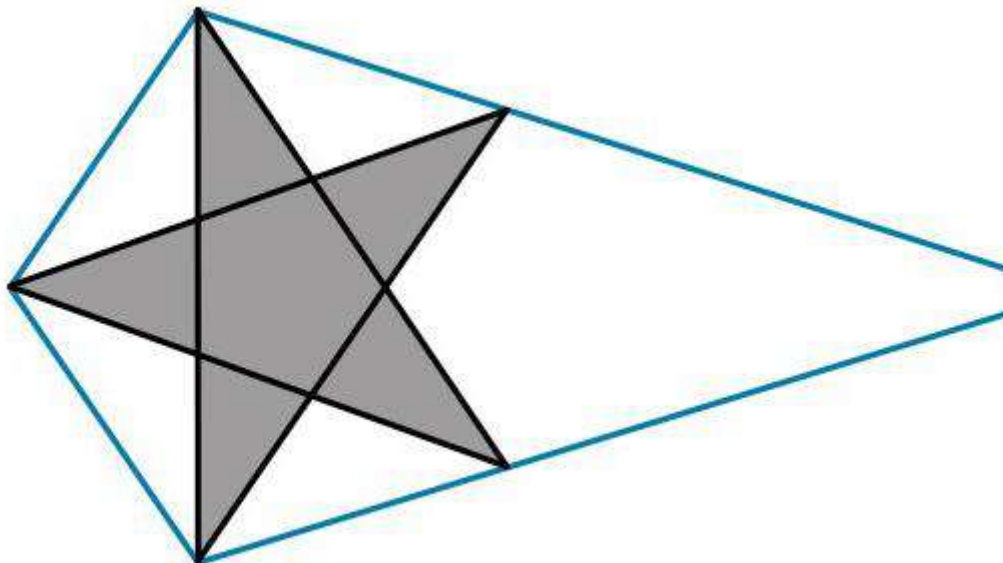

Q.04 A dice throw can result in the numbers 2,3,5 or 6. Every 4th throw will result in 3. What is the minimum number of times the dice has to be thrown for the pawn to move from zero to reach exactly at 100?

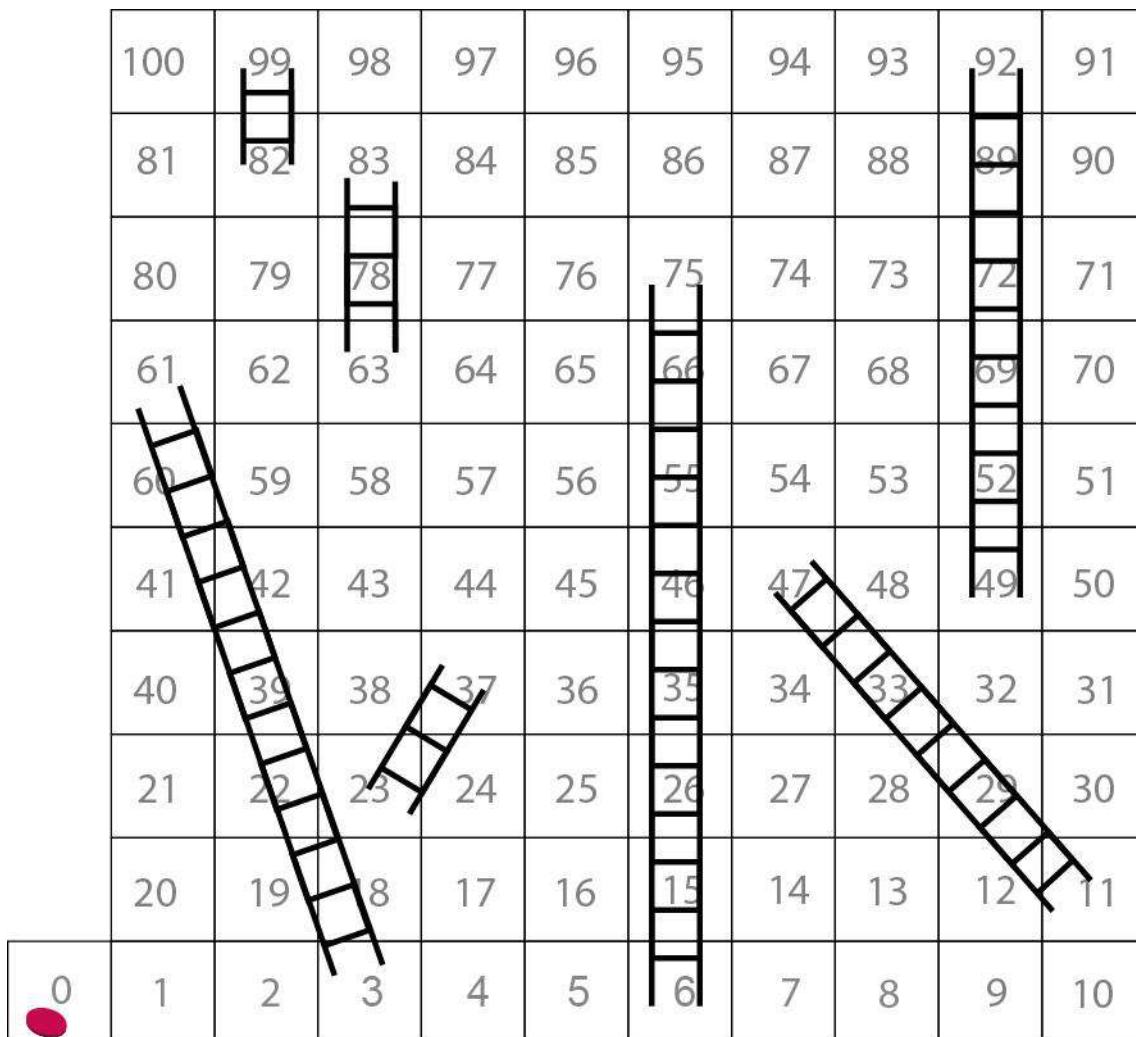

Q.05 Count the number of human figures in the picture.



Q.06 In the figure given below, the area of the largest regular hexagon is 720 units. What is the area of the shaded portion?

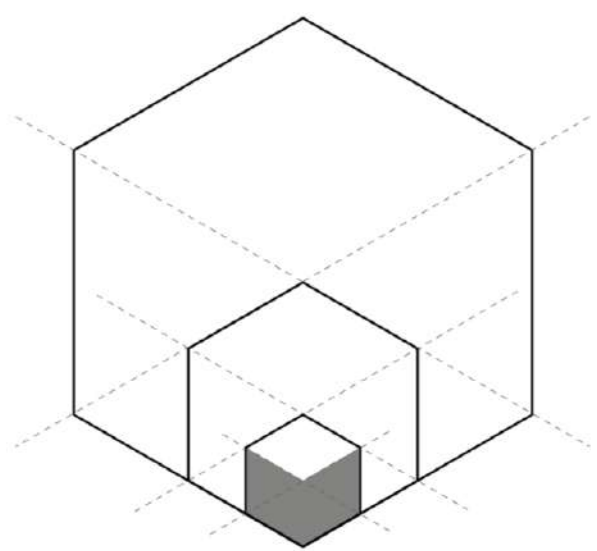

Q.07 A tetrahedron of side 18 units and a cone having base diameter of 10 units are cutting through a sphere as shown. Count the total number of surfaces in the resultant sphere.

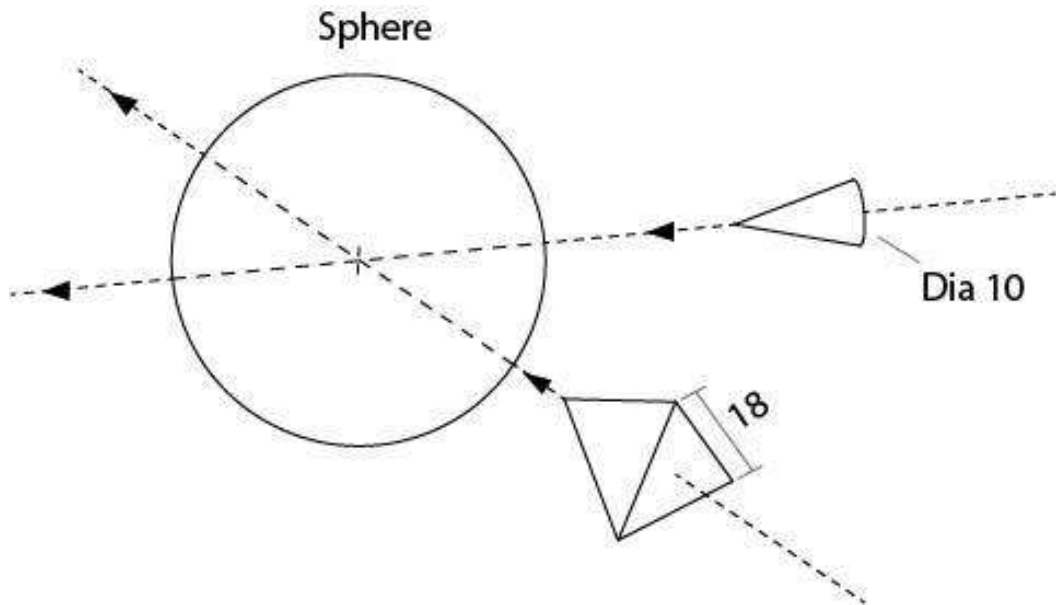

Q.08 Tim cycled from his house to his friend John's house and then on to his (Tim's) school without stopping. The average speed for his entire journey was 26 km/hr. The distance from John's house to Tim's school is 0.3 times the distance from Tim's house to John's house. Tim's speed from John's house to Tim's school was twice that of Tim's speed from Tim's house to John's house. What was Tim's average speed from John's house to Tim's school in km/hr?

Q.09 Identify the total number of differences in the images shown below.



Q.10 Count the number of cats in the given image.

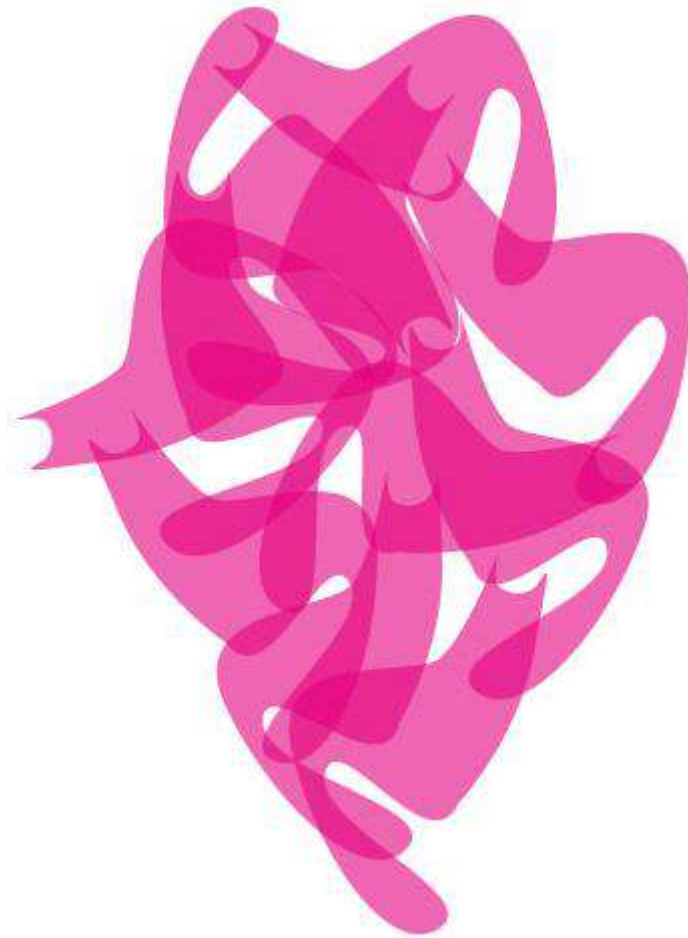

Q.11 Two trains of unequal length have speeds of 60 and 50 km/hr. When they travel in opposite directions in straight line tracks, they take 9 seconds to completely cross each other. When they travel in the same direction, a person in the faster train sees the slower train for 18 seconds. For how much time (in seconds) would a person in the slower train see the faster train when the trains travel in the same direction?

Q.12 The image shows the profile of the blade which is designed to turn a wooden block, rotating about the axis PQ. Calculate the volume of the turned wooden block between P and Q. Consider the value of π to be $22/7$.

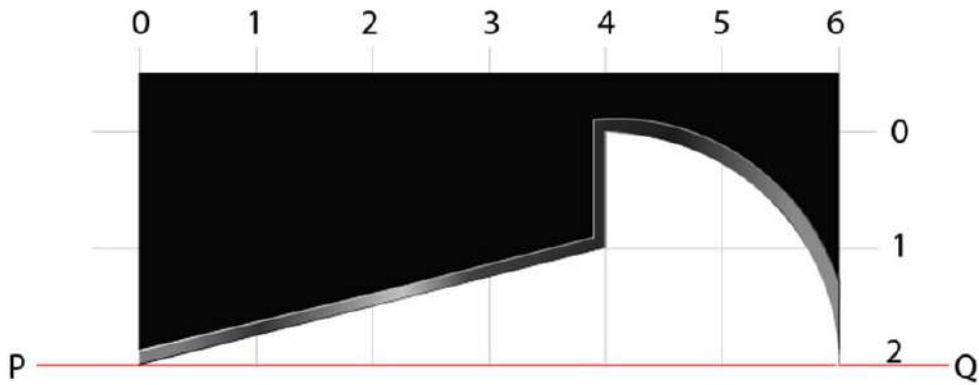

Q.13 A blue colour liquid is used completely to make a star shaped jelly using the mould shown on the right. What is the value of 'X' in cm? Ignore the wall thickness of the mould and consider the value of π to be $22/7$.

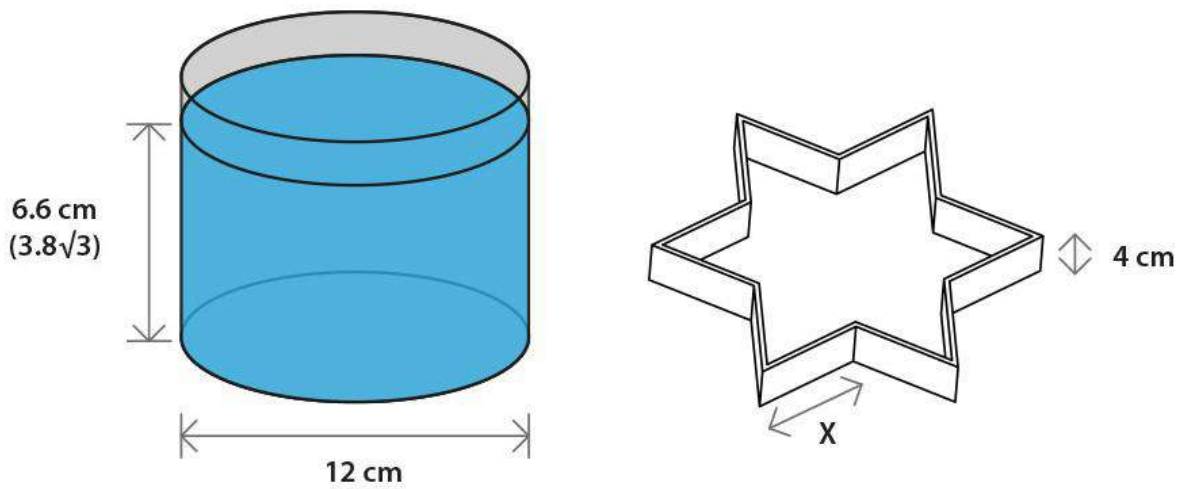

Q.14

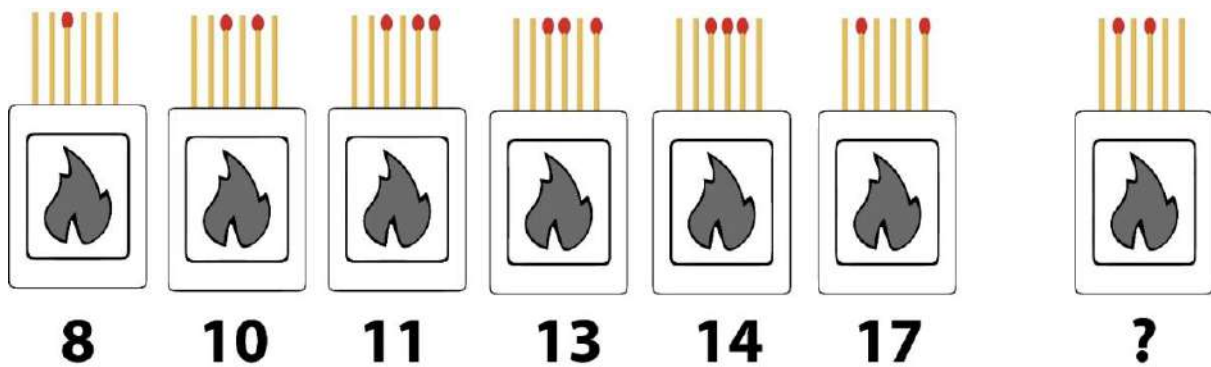

Q.15 Shown below are four sides of a rectangular dice. If 3 such dice are thrown together, what is the probability of getting a total sum of 4? Consider the value of the blank side to be zero.

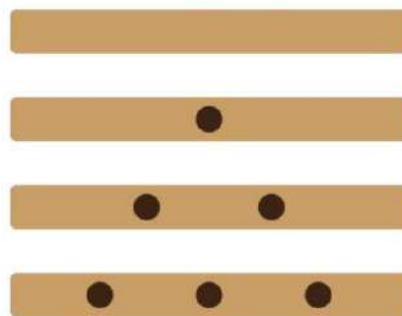

Q.16 How many distinct types of characters appear in the figure given below?

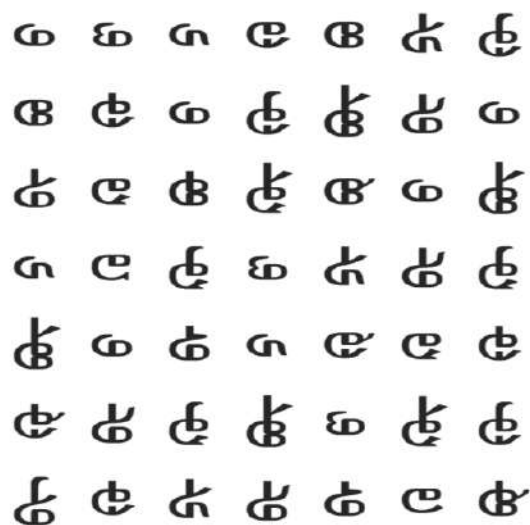

Q.17 Objects made out of cardboard are shown in the image below. Count the number of objects shown as open containers in this image.

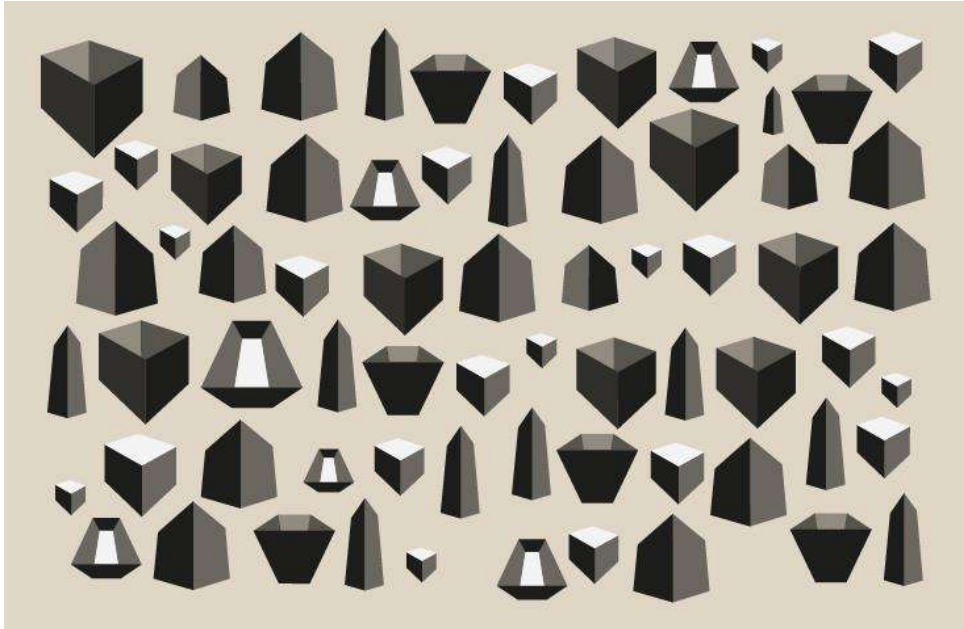

Q.18 A triangular pyramid with equal sides can be flipped on its edges without slipping or sliding as shown on the left. What is the minimum number of flips needed for the pyramid to reach the finishing line if the starting position is as shown on the right?

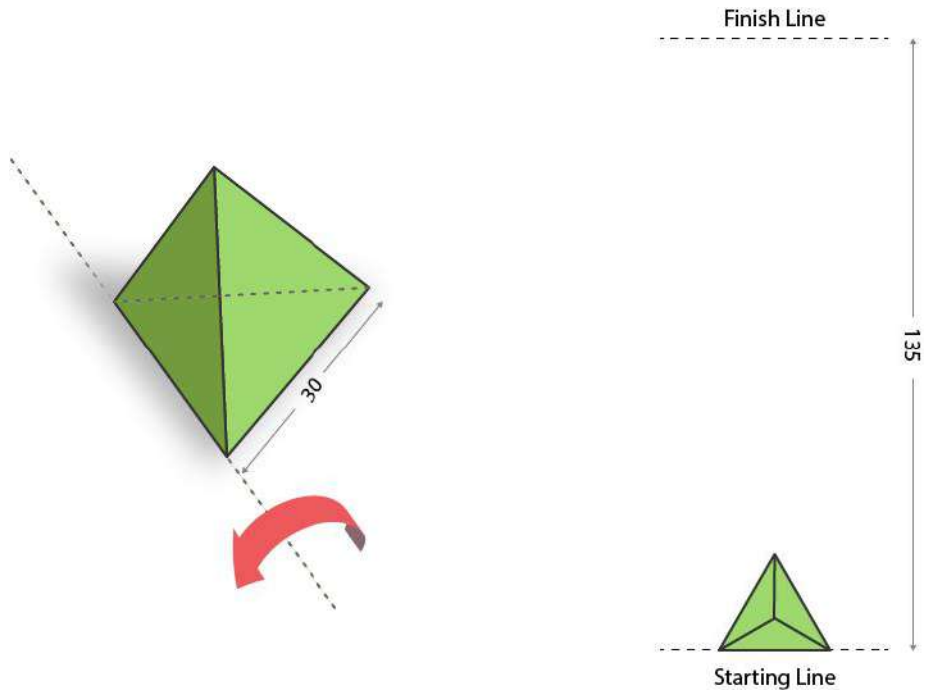

Section 2: Multiple Select Questions (MSQ)

Section 2 (72 Marks) of Part A contains a total of 18 **Multiple Select Questions (MSQ)**. Each question may have **one or more than one correct choice(s)** out of the four given. The following is the marking scheme:

Full Marks : + 4 *If only (all) the correct option(s) is(are) chosen and NONE of the incorrect options is chosen*

Partial Marks : + 3 *If all the four options are correct but ONLY three options are chosen and NONE of the incorrect options is chosen*

Partial Marks : + 2 *If three or more options are correct but ONLY two options are chosen, both of which are correct and NONE of the incorrect options is chosen.*

Partial Marks : + 1 *If two or more options are correct but ONLY one option is chosen and it is the correct option and NONE of the incorrect options is chosen.*

Zero Marks : 0 *If NONE of the options is chosen (i.e., the question is unanswered);*

Negative Marks: -1 *In all other cases.*

Questions from 19 to 36 belong to this section.

Q.19 Shown in the top row are 4 pieces of building blocks. Which of the option(s) is/are made using all four pieces?

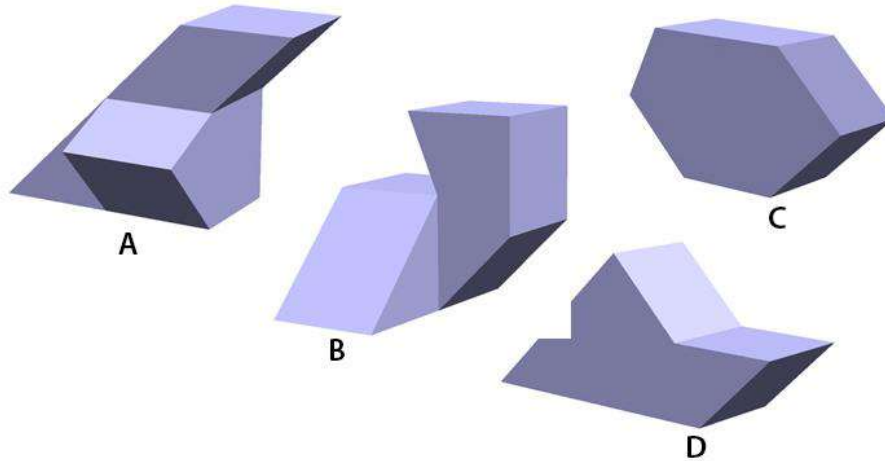
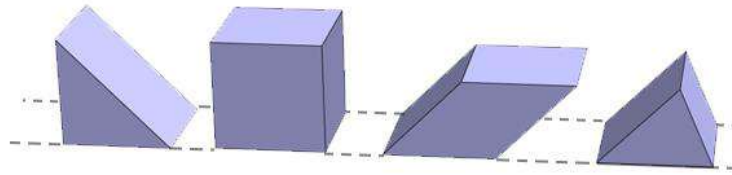

Q.20 A printer wishes to print four colours, Crimson, Pink, Brown, and Indigo, using CMYK [Cyan, Magenta, Yellow and Key (black)] inks. The printer uses the CMYK combinations shown below (in % of each ink) to produce the colours on the right. Which combination(s) will result in the correct colour(s)?

C = 05%
 M = 90%
 Y = 70%
 K = 05%



Crimson

A

C = 05%
 M = 15%
 Y = 70%
 K = 00%



Pink

B

C = 50%
 M = 50%
 Y = 100%
 K = 05%



Brown

C

C = 50%
 M = 90%
 Y = 00%
 K = 05%



Indigo

D

Q.21

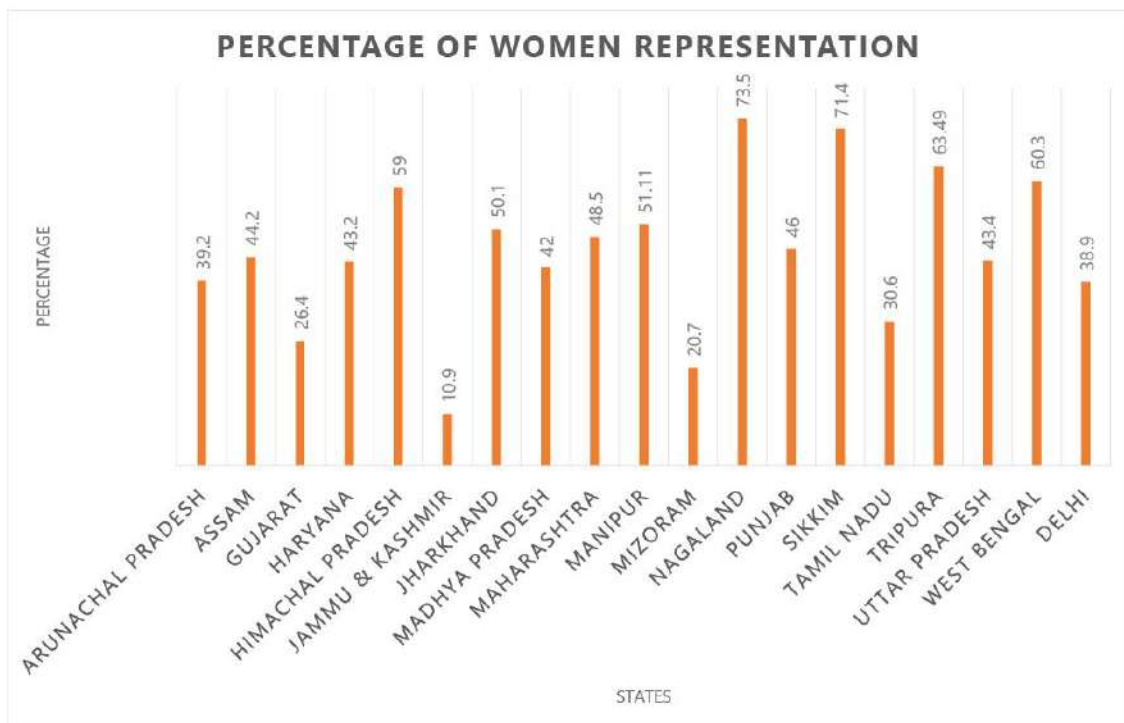
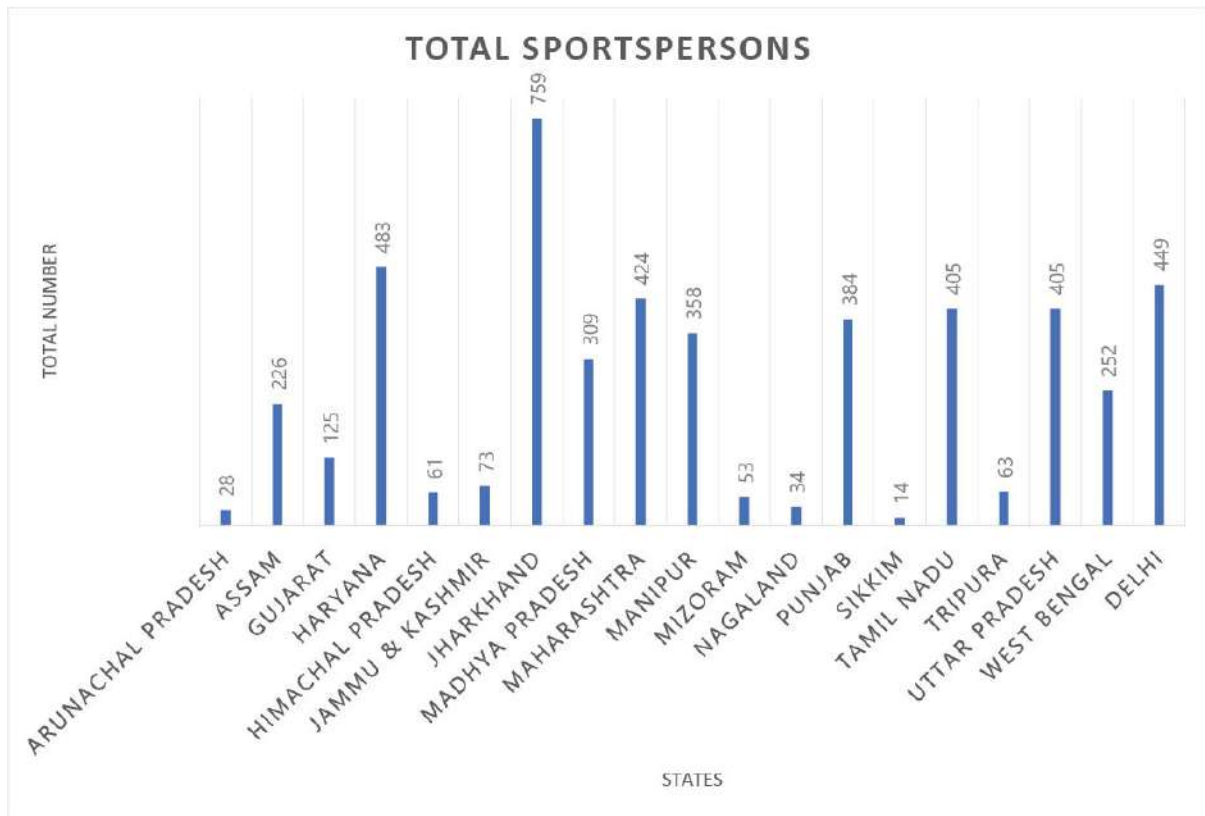

Which of the statement(s) is/are true?

- A. Jharkhand has the highest number of sportspersons but its percentage of women representation is not the highest.
- B. Of all the North-Eastern states, Nagaland produces the highest number of sportspersons.
- C. Jammu & Kashmir has low number of sportspersons but high women's representation.
- D. Even though Tamil Nadu and Uttar Pradesh have the same number of sportspersons, Uttar Pradesh fares higher in women's representation as compared to Tamil Nadu.

Q.22 The figure below shows four mechanisms made using links and hinges. If circles represent hinges, which of the option(s) will allow relative motions between the links?

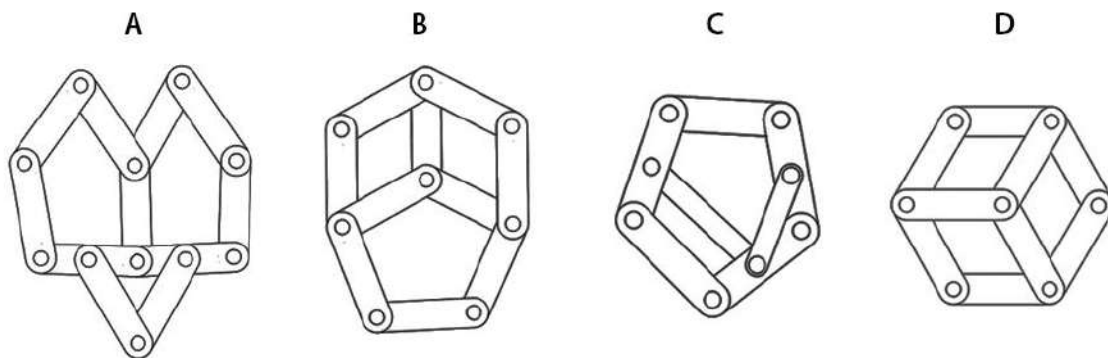

Q.23 Shown on the left is a sheet of stickers. Identify the option(s) in which monkeys of the same species are sitting together.

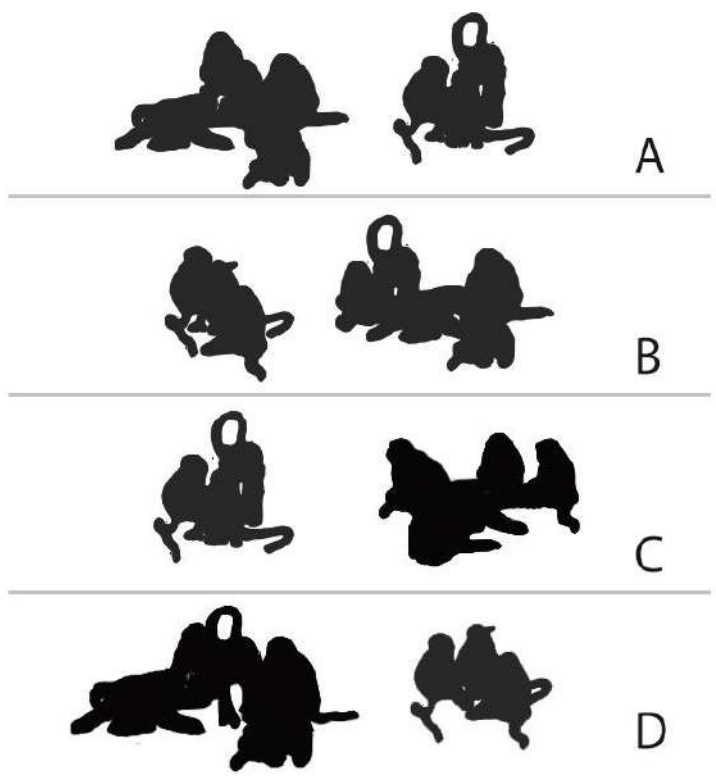

Q.24 Different views of the cross section of a fish toy are shown here. The points P and Q are connected in such way that the fish tail waves. The grey colour gear and the green colour part are joined together. The rod is free to move depending on how it is connected to the green part. Which of the option(s) will work to wave the tail?

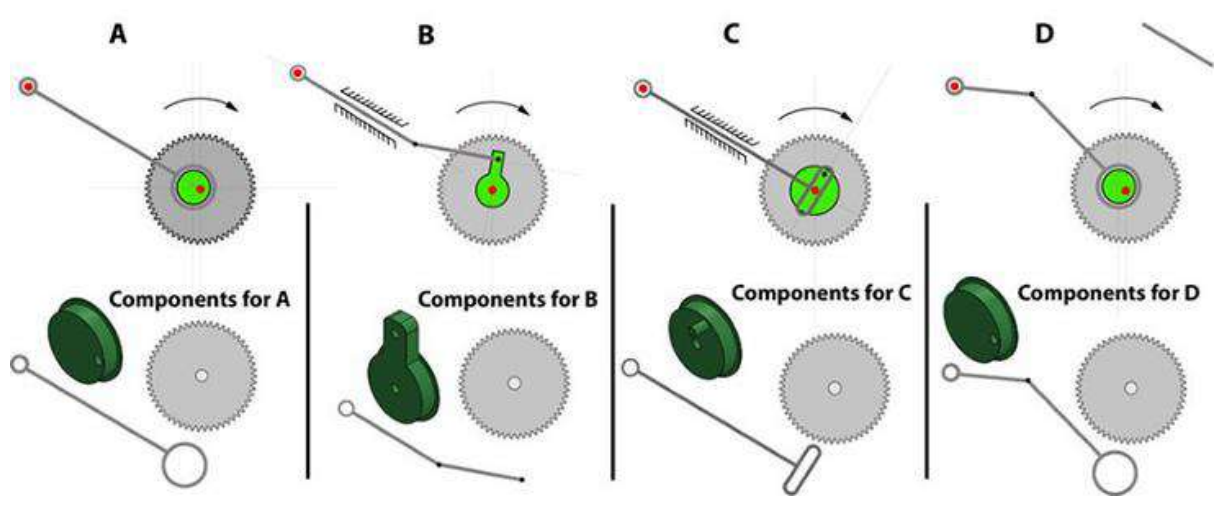

Q.25 A tourist is shooting photographs of an ancient building from four locations A, B, C and D marked by x. The tourist is using only one camera without changing its magnification. Identify the location(s) in the floor plan which will result in the given photograph.

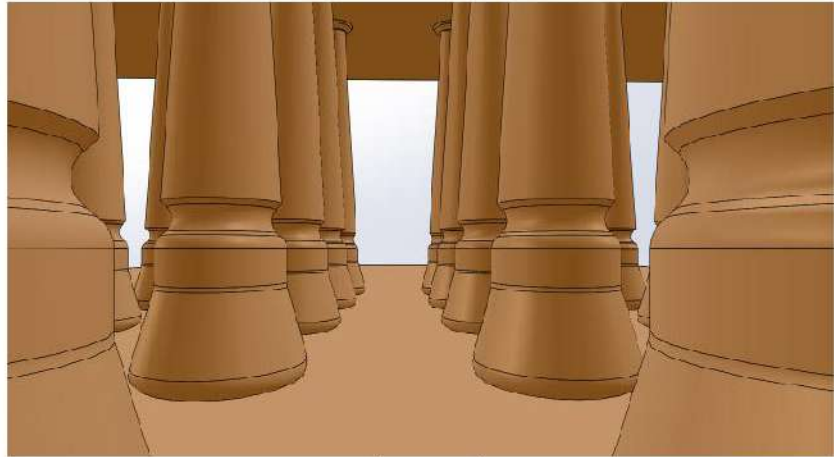
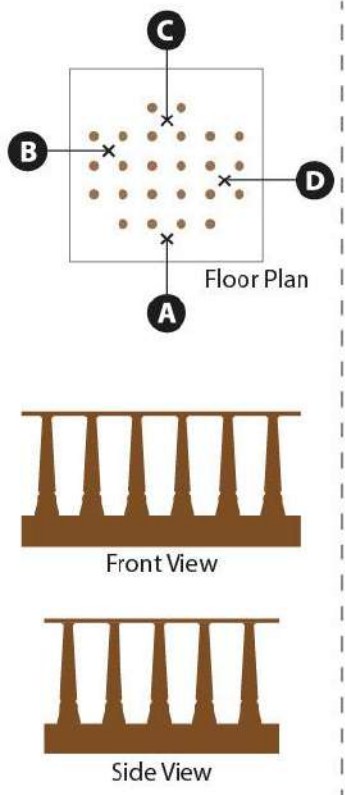

Photograph

Q.26 The options show four ways of attempting to write the word "universe" in a mix of lower-case and upper-case letters. Which of the option(s) is/are correctly read as "universe"?

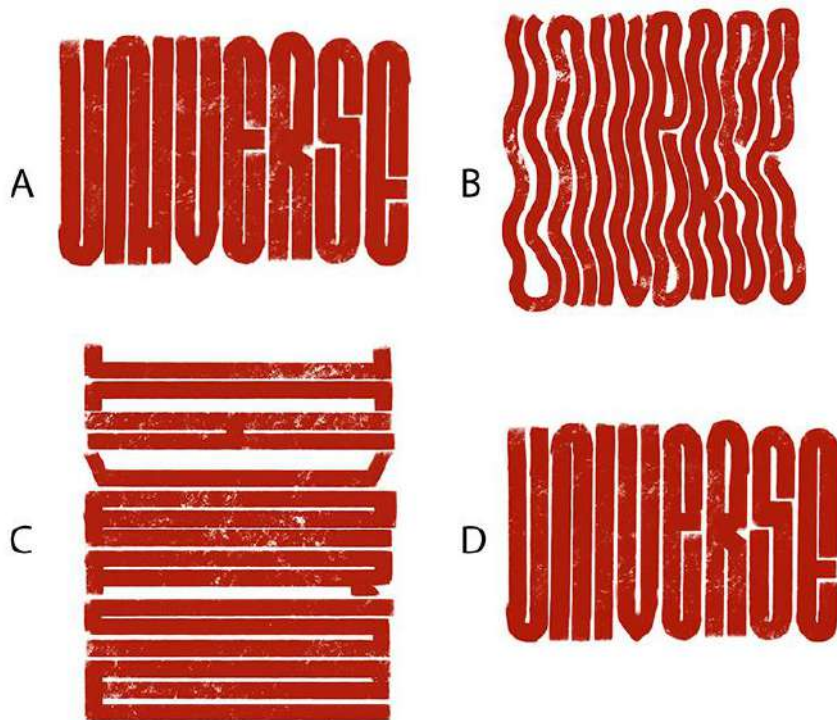

Q.27 Which of the option(s) is/are from the same font family (i.e. weight and/or width variations) of the words given below?

मुद्राक्षर अभिकल्प

फेड वात धागा अकल
A B C D

Q.28 Which of the pieces could be used four times individually to form a square? The pieces can be rotated and flipped but should not be overlapped.

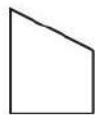

A

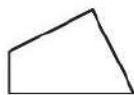

B

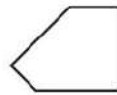

C

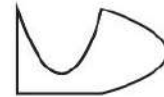

D

Q.29 Shown below is a coconut broken into two pieces. Identify the correct representation(s) of the coconut.

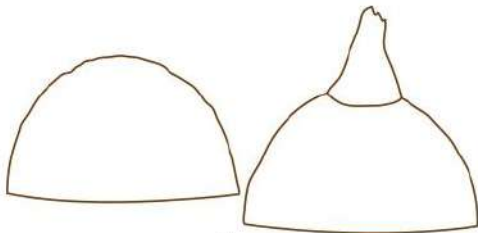

A

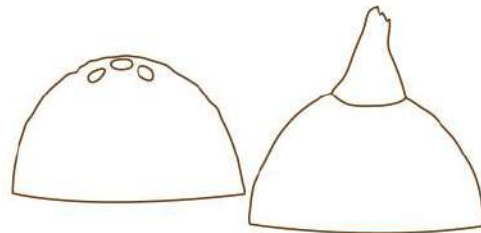

B

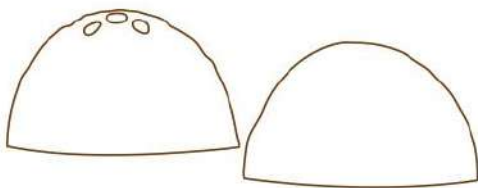

C

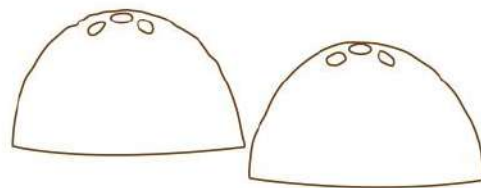

D

Q.30 Shown below is an image of solid rings of black and white patterns. A ring going inside another is called a link. Which of the statement(s) is/are TRUE.

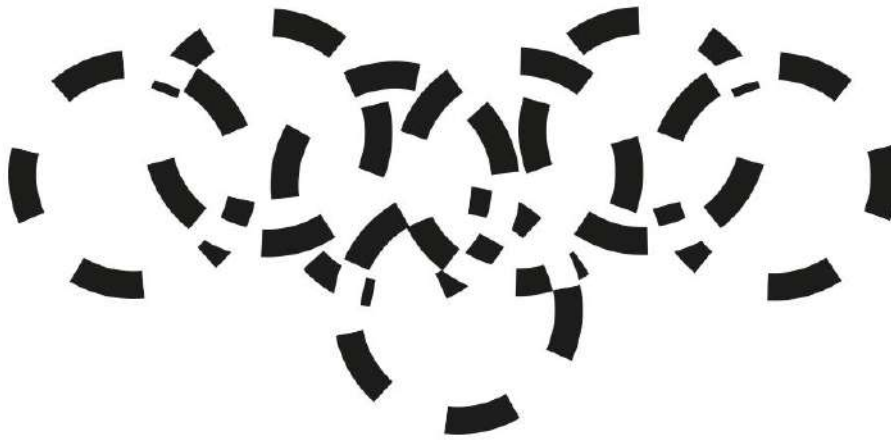

- A. All rings are linked to form one continuous chain.
- B. One ring does not have any link.
- C. One ring has three links.
- D. Two rings have only one link.

Q.31 The options show different configurations of refill bottles of mosquito repellent, for an atypical socket shown on the left. After fitting, the red mark on the refill bottle must align with the red mark on the machine. Which of the option(s) will allow all of the liquid to be consumed?

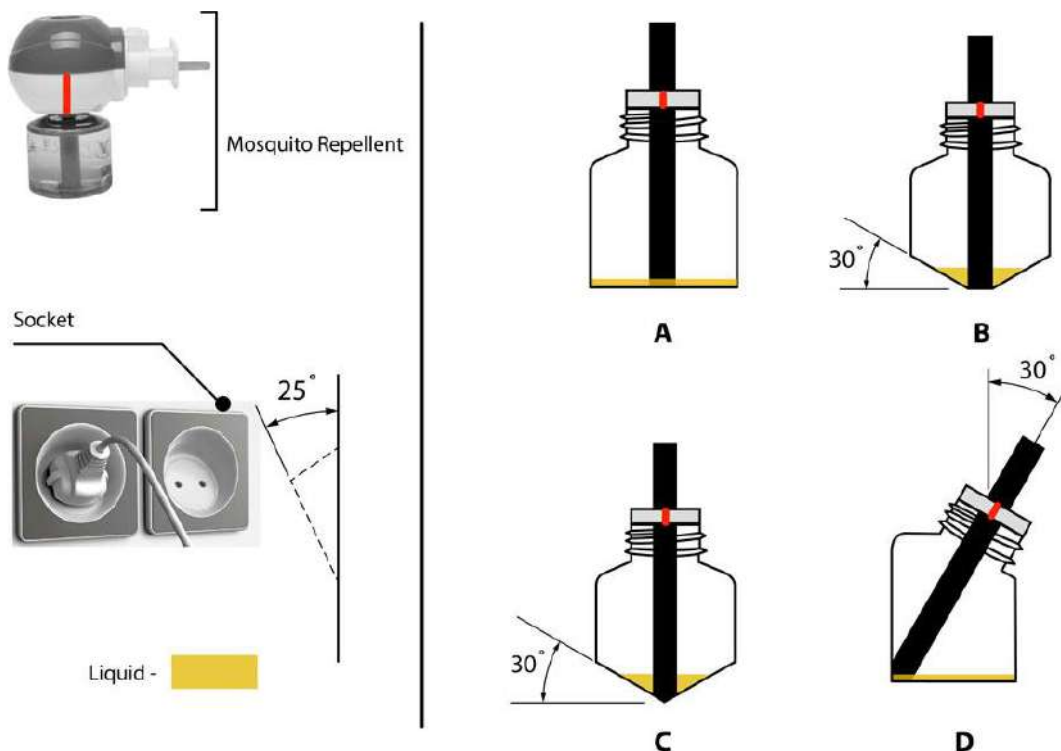

Q.32 With reference to the image below, which of the statement(s) is/are false?

- A. Ramps are good solution for standard wheel chair users to access any building with entry above ground level.
- B. Height along with the length of the ramp will determine if standard wheel chair users can use it without assistance.
- C. People on standard wheel chair will need assistance to go up and down shorter length ramps irrespective of its height.
- D. A shorter length of ramp is convenient for standard wheel chair users without assistance, if the height of the ramp is high.

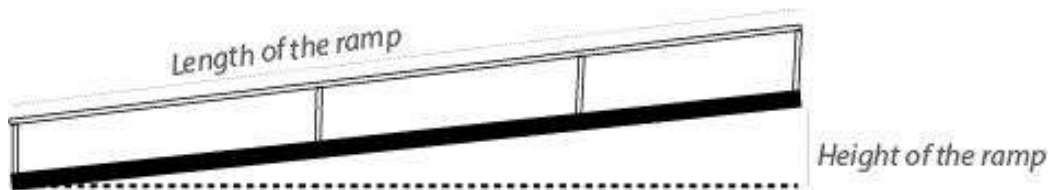

Q.33 In which of the option(s) dust-bin lids will open?

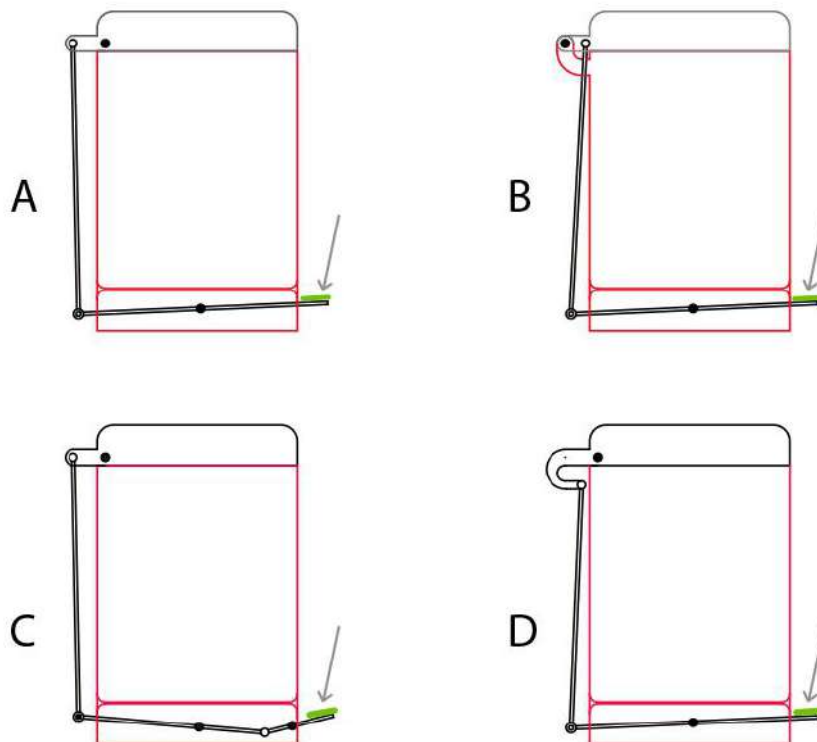

Q.34 On 16th July 2022, Parvathy bought 4 new pairs of socks A, B, C and D to train herself for the Marathon race on Gandhi Jayanti. She started her training next day wearing the new socks. She trained every day, including the day of the marathon, wearing the socks (one pair every day) in the following sequence: C, A, B and D. Unfortunately, she could not train from 3rd to 22nd September 2022 as she was unwell. She resumed her training on 23rd wearing pair 'A' socks and continued with the same sequence till the event day. Identify the pair of socks that Parvathy wore the maximum during her entire training period.

Q.35 The rectilinear hollow box shown on the left is cut along plane 1 and plane 2. Which of the option(s) show(s) correct unfolded pieces?

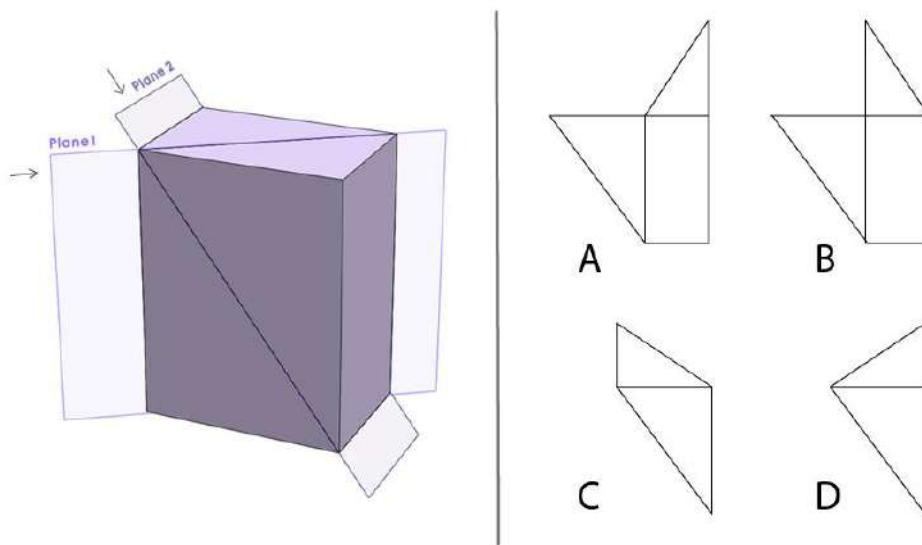

Q.36 Shown below are tables of a new design. Which table(s) will not tilt, if given a small perturbation in any direction?

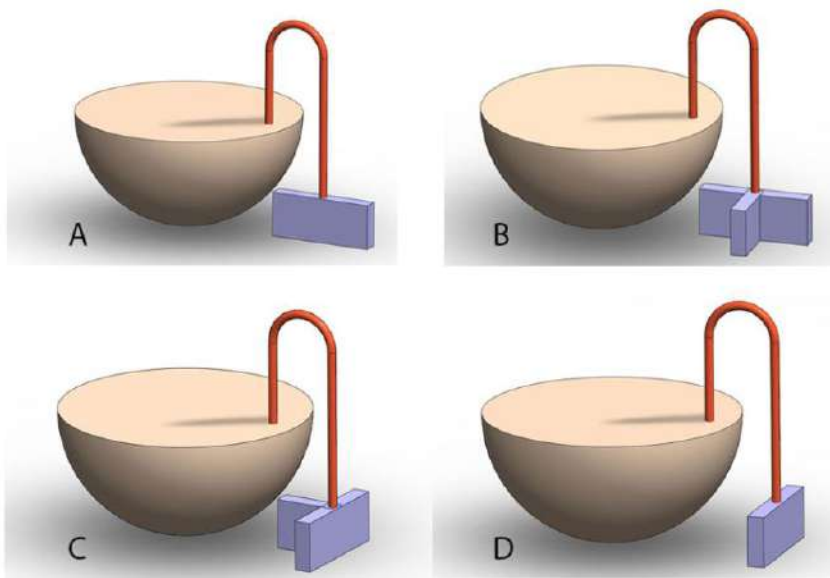

Section 3:

Multiple Choice Questions (MCQ)

Section 3 (96 Marks) of Part A contains a total of 32 **Multiple Choice Questions (MCQ)**. Each question has four choices out of which **ONLY ONE** is the correct answer. There is **NEGATIVE** marking for this section. Each correct answer will be awarded 3 marks and each wrong answer will receive -0.71 (minus point seven one) mark. Questions not attempted will be given zero mark. Questions from 37 to 68 belong to this section.

Q.37 Imagine that you are travelling in a passenger train, with 22 coaches, depicted by curved black lines in the options. You are sitting on a window seat in the 19th coach (seat position marked as P). At a given instant of time when the train is heading northwards, select the option which will allow you to see the engine at the front clearly through the window of your seat.

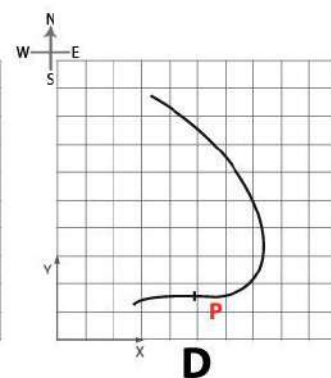
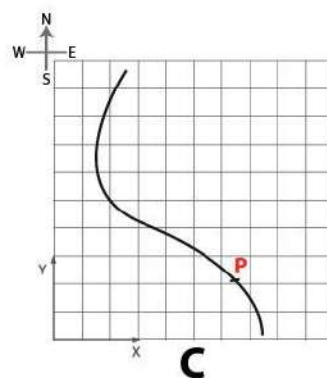
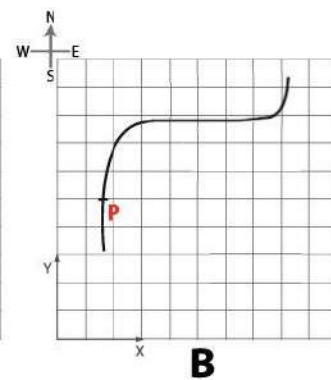
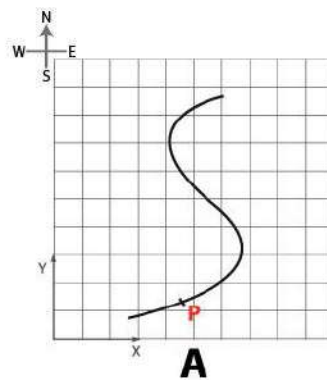
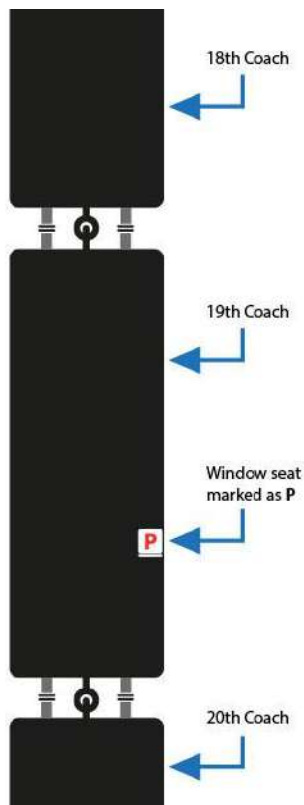

Q.38 Which of the moulds shown on the right can be used to make the cake shown on the left?

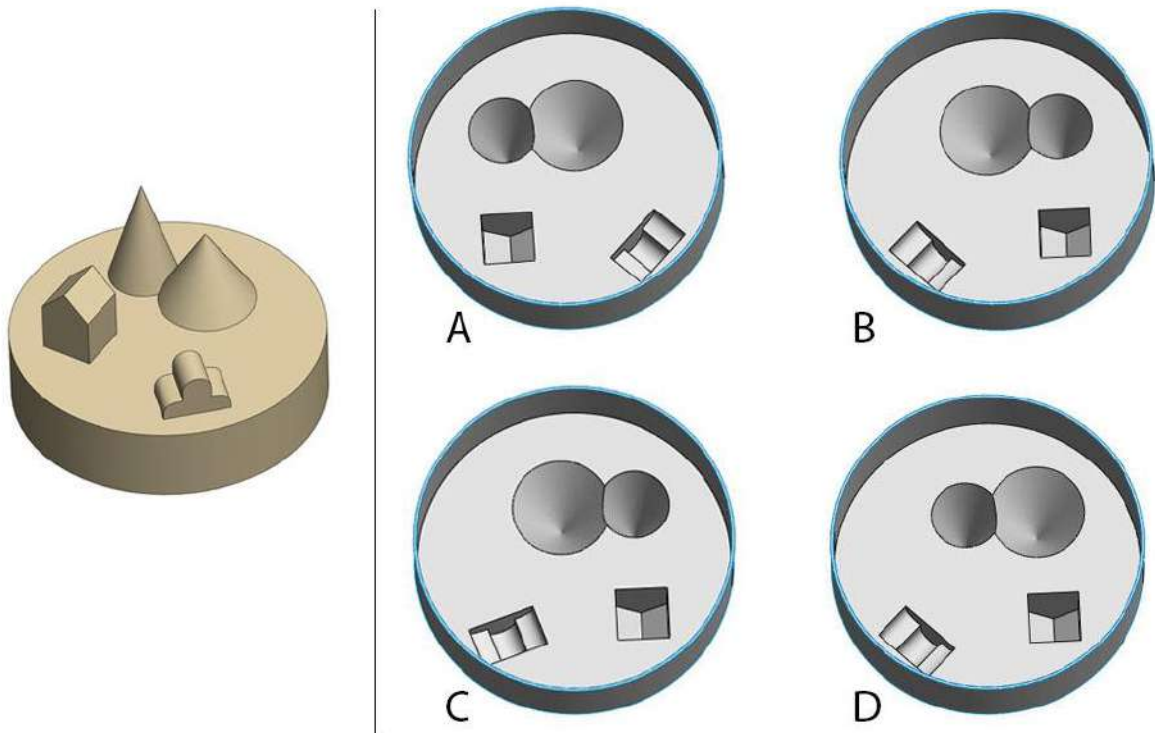

Q.39 Which of the options shown on the right, when folded at the lines, will resemble the paper shown on the left?

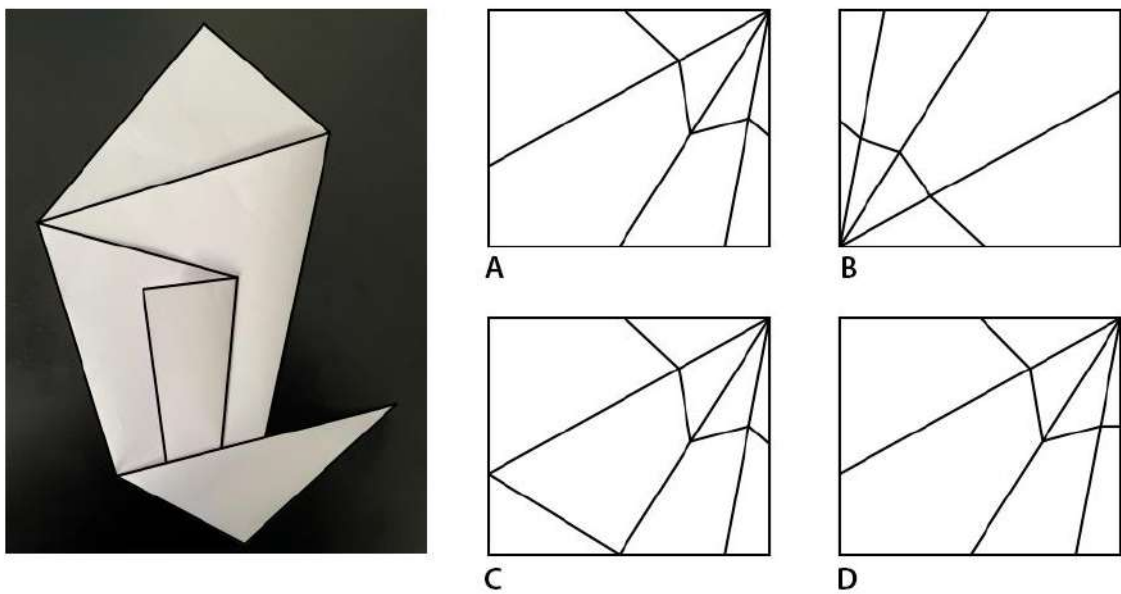

Q.40 The faces of a solved Rubik's Cube are shown in the figure. A 90 degree clock wise turn of a face T is denoted as 'T+' and 90 degree anticlockwise rotation is denoted as 'T-'. What is the result of the operation T+, D+, R-, L-?

All operations are done looking directly at the face.

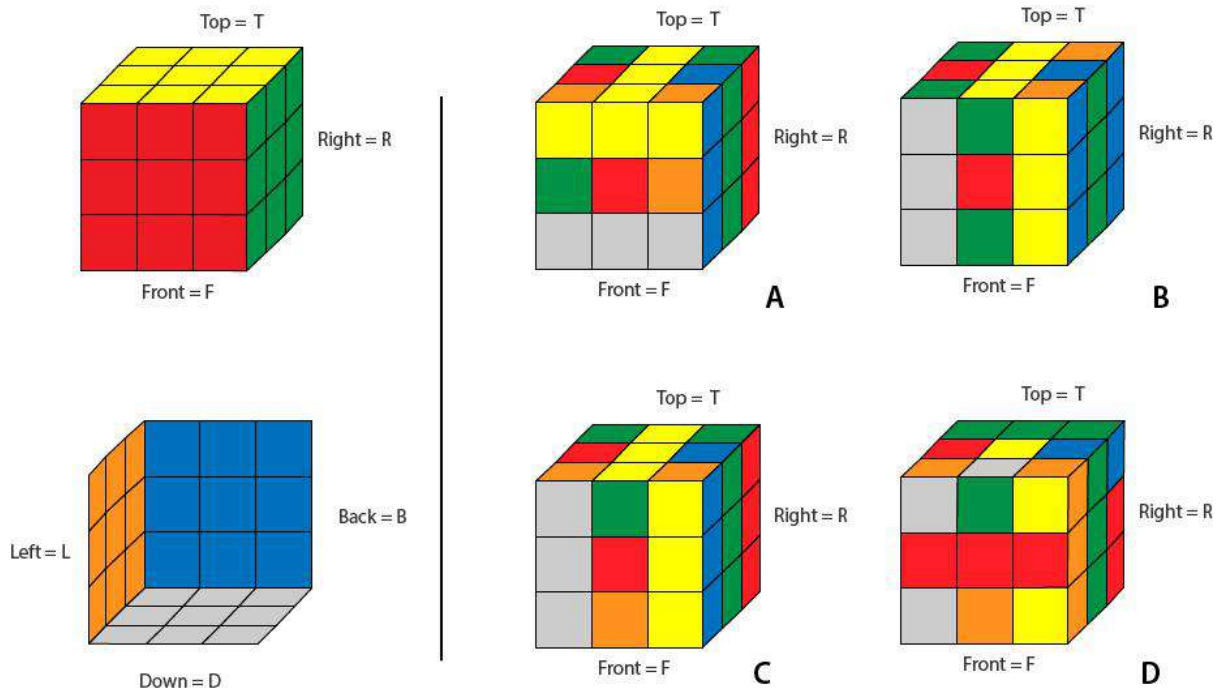

Q.41 Shown on the left are all the 6 faces of a cube. Which option can be folded into this cube?

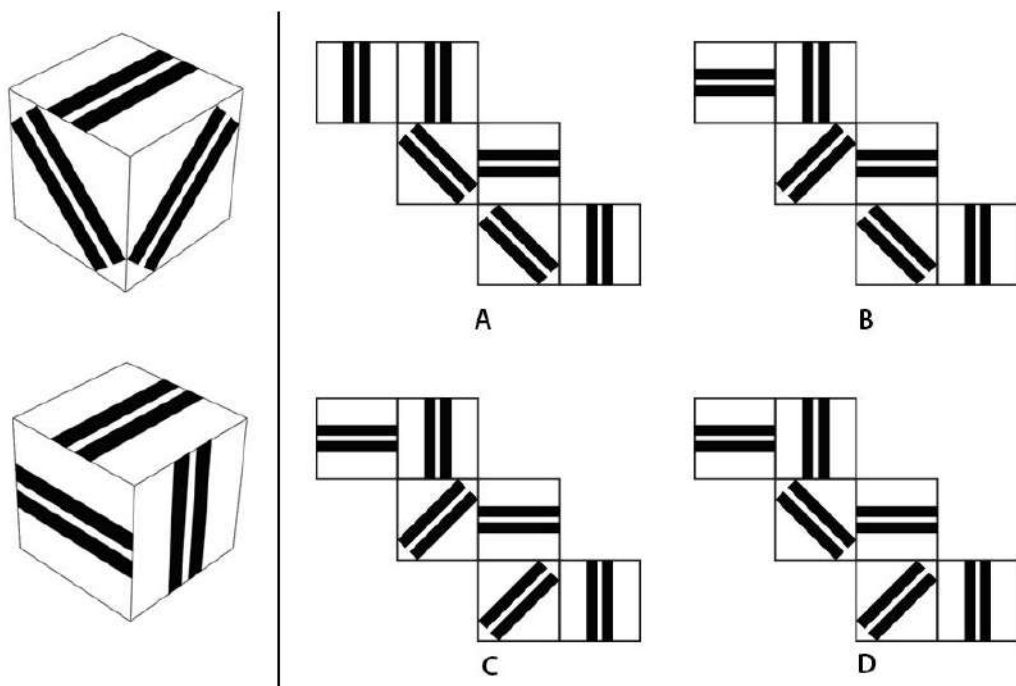

Q.42

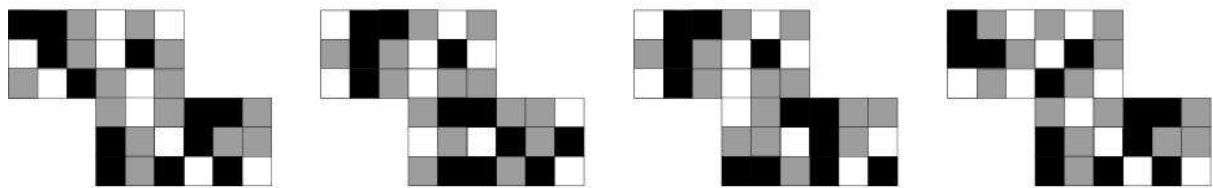
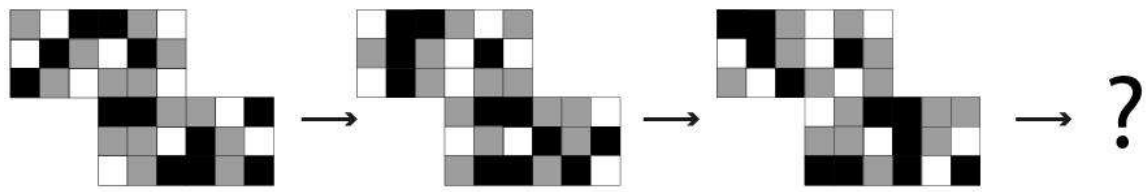

A

B

C

D

Q.43 The white part in the shoe sole shown left represents the embossed / raised area. Find out the right footprint of the shoe from the given options.



A



B













































C



D

Q.44

	=	   		A	   
	=	   		B	   
	=	   		C	   
	=	   		D	   
	=	   			
	=	?			

Q.45 The following operations are done on the curve shown in the figure.

1. The curve is revolved 360 degrees around the Y axis.
2. The resulting form is then cloned twice around the X axis at 120 degrees to each other.
3. The resulting form is then cloned once about the Y axis at 90 degrees.

What is the resulting 3D form?

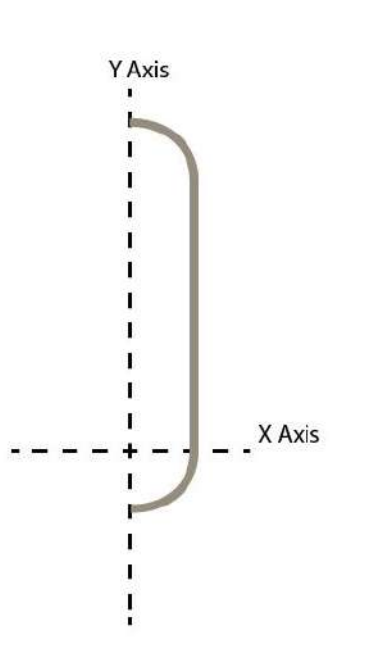
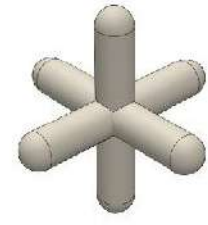
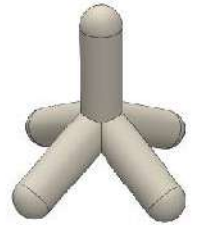
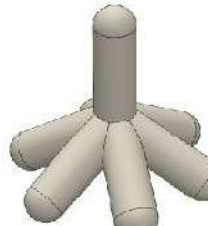
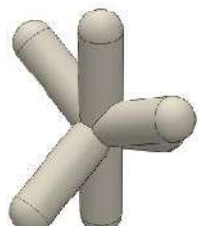
	 A	 B
	 C	 D

Q.46 Which combination shows lunar eclipse?

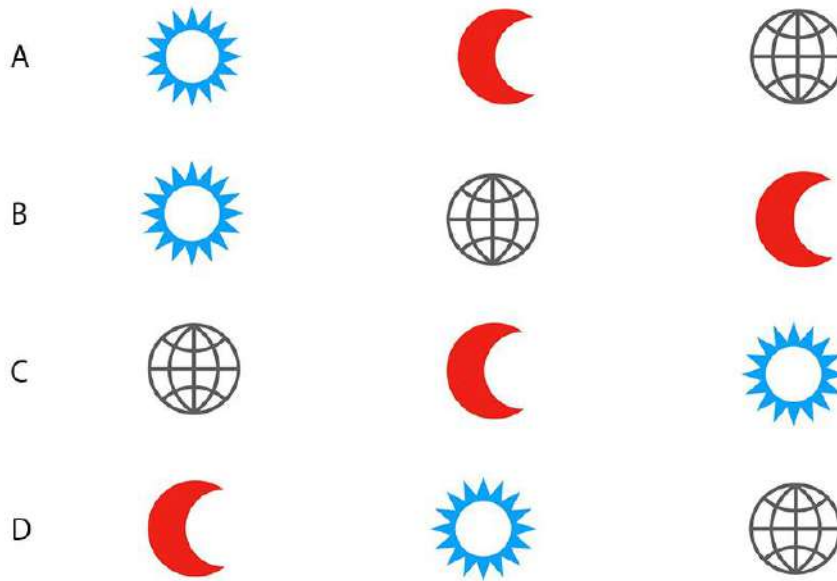

Q.47 A boat is moving on the river and following the path as shown by the dashed line. Both the boatmen are facing front and rafting with equal force in the directions shown by the arrows in the options. Which of the options will help the boat to take a right turn?

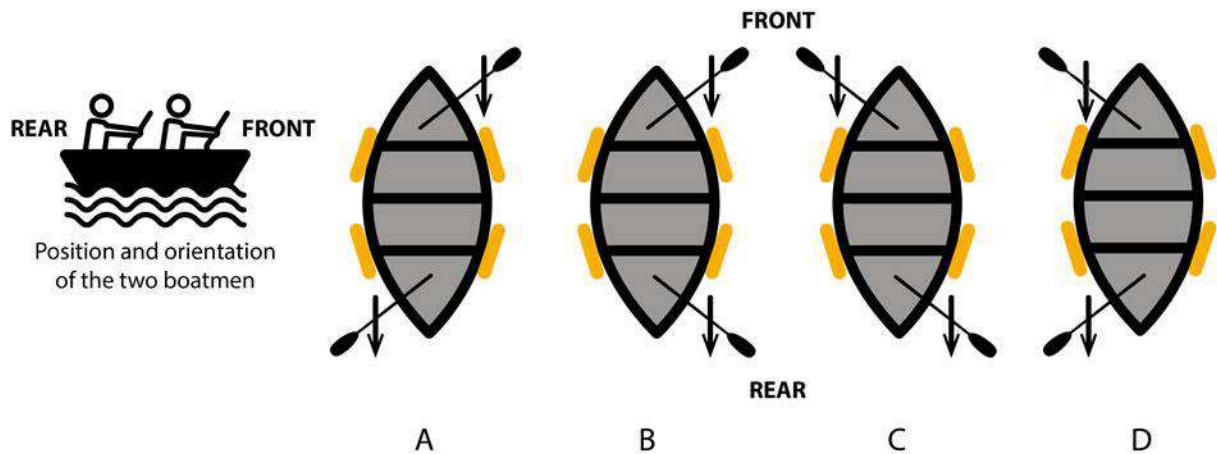

Q.48 Select the correct sunshade pattern on the illustrated structure. Assume Sun at 45 degree on left as shown.

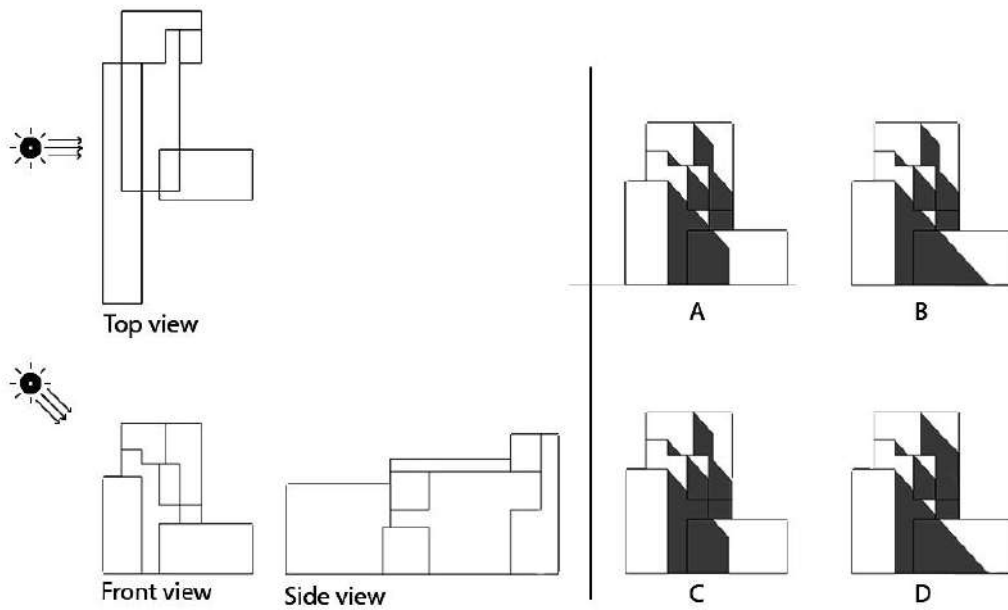

Q.49 Which option, when folded, will result in the solid shown?

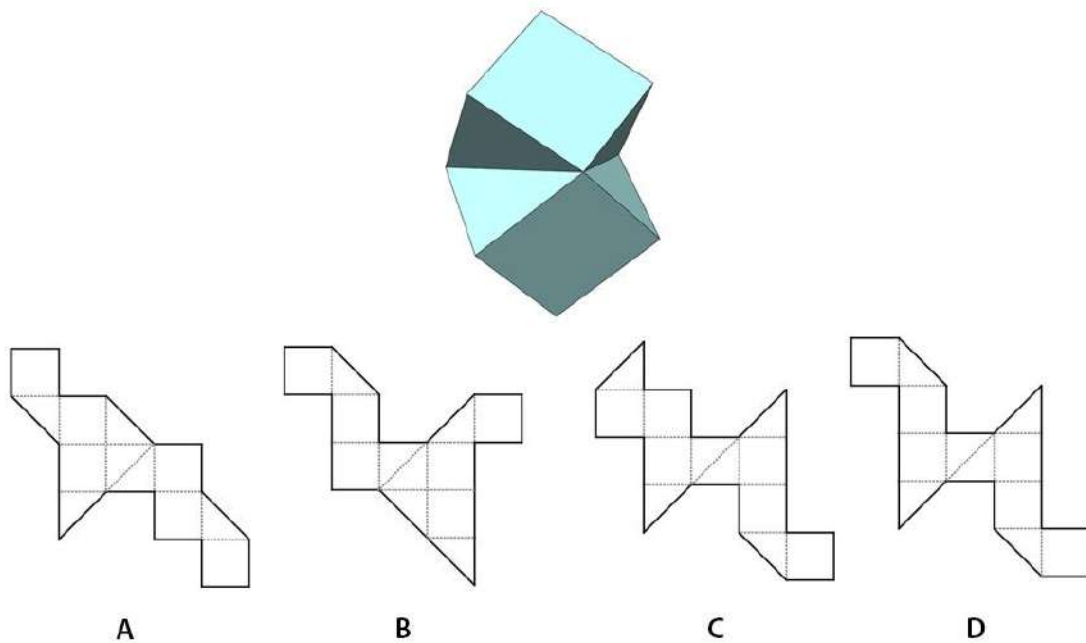

Q.50 The options show designs for a remote control and its battery cover. Which design will be feasible?

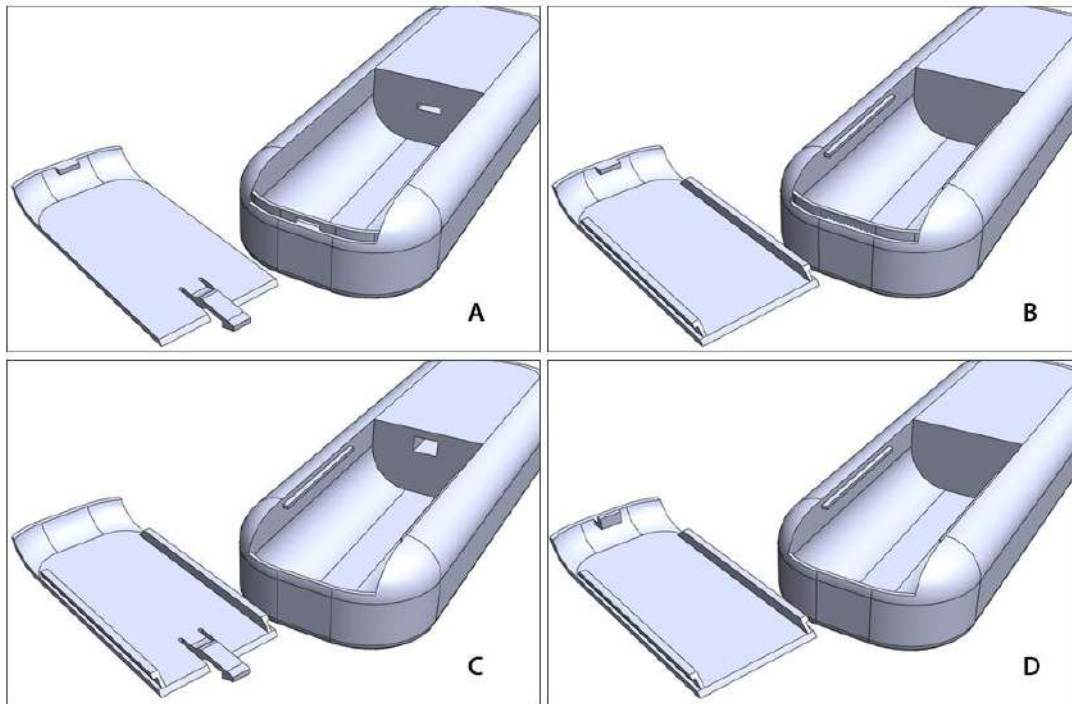

Q.51 Four keyboard layouts were designed to enter text on touch-screen mobile phones. Which of these layouts has the shortest finger travel distance for entering text in the English language? Assume, the mobile is held vertically in the left hand, and a right-handed user presses the keys using only the index finger of the right hand.

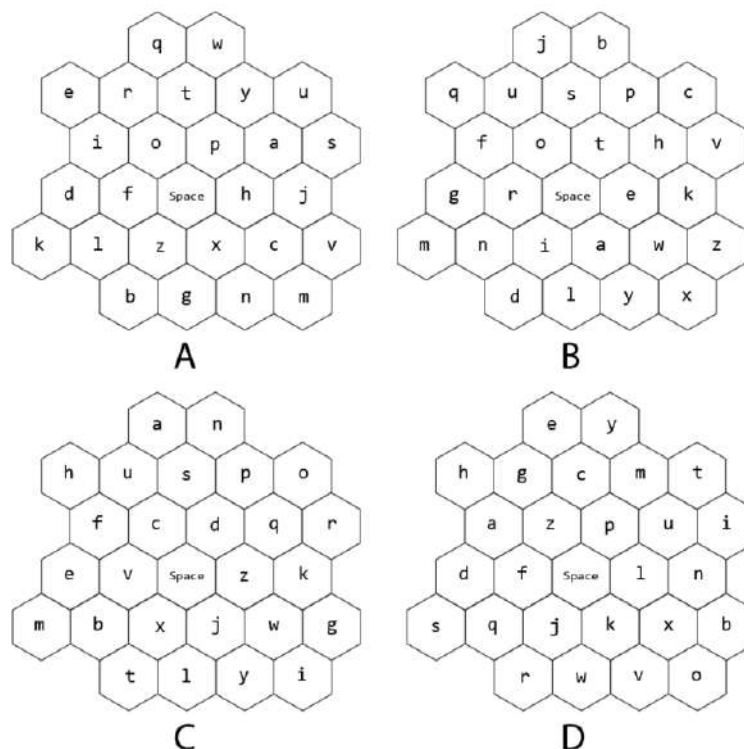

Q.52

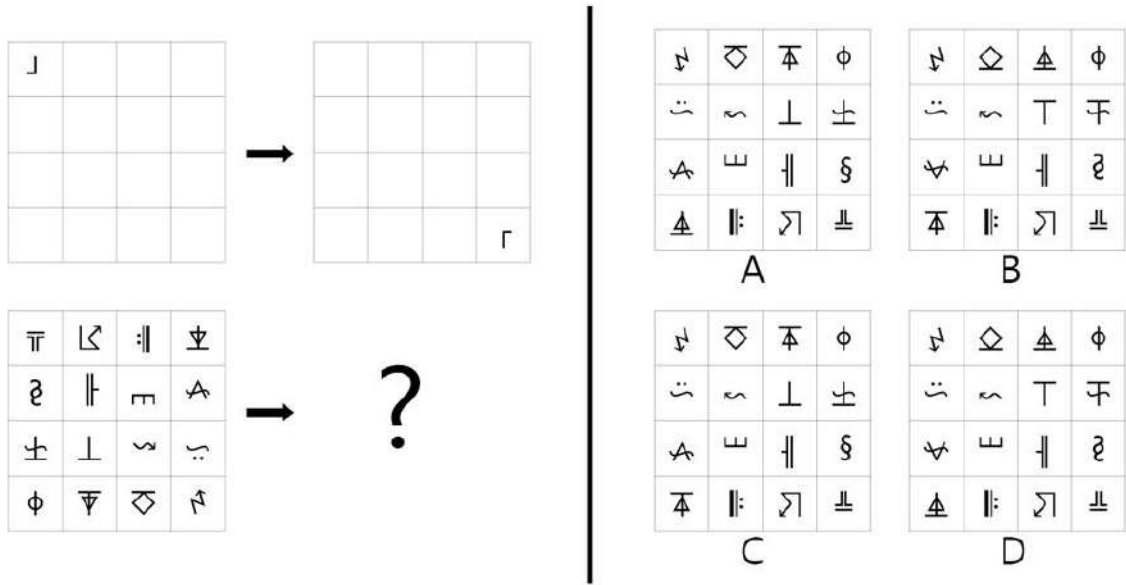

Q.53 Refer to all the sides of a vase shown below.

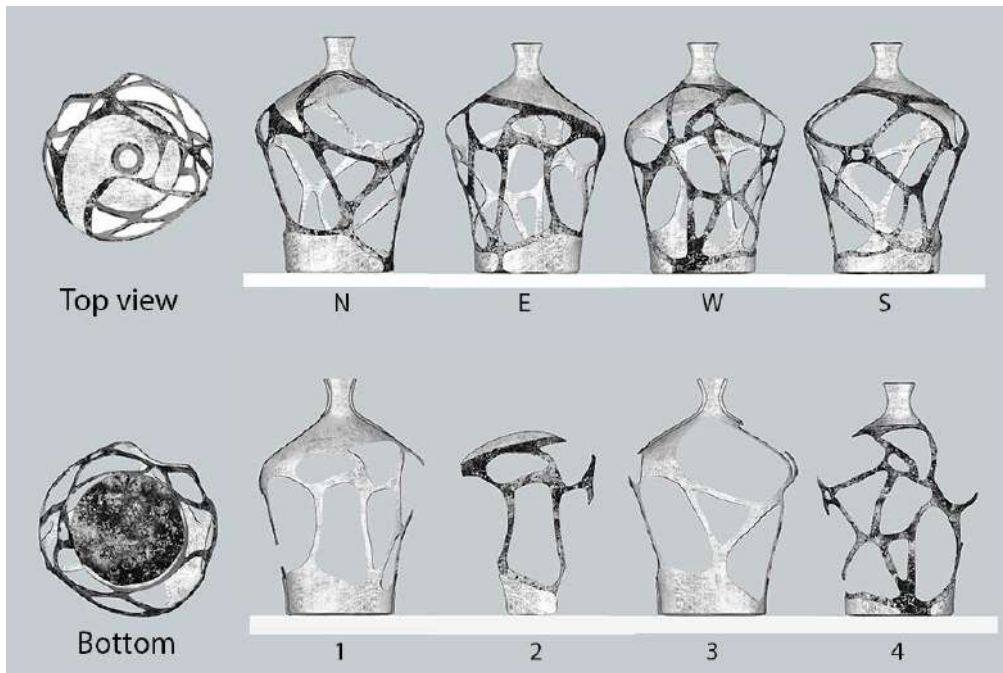

Select the correct order of sectional faces.

- A 1. Inside eastward, 2. Outside westward mirrored, 3. Inside westward, 4. Outside westward mirrored
- B 1. Inside westward, 2. Outside eastward mirrored, 3. Inside southward mirrored, 4. Outside westward mirrored
- C 1. Inside westward mirrored, 2. Outside eastward mirrored, 3. Inside southward, 4. Outside northward

D 1. Inside southward, 2. Outside eastward mirrored, 3. Inside westward, 4. Outside northward

Q.54 Which of the options can be made by following the instructions given in the image below?

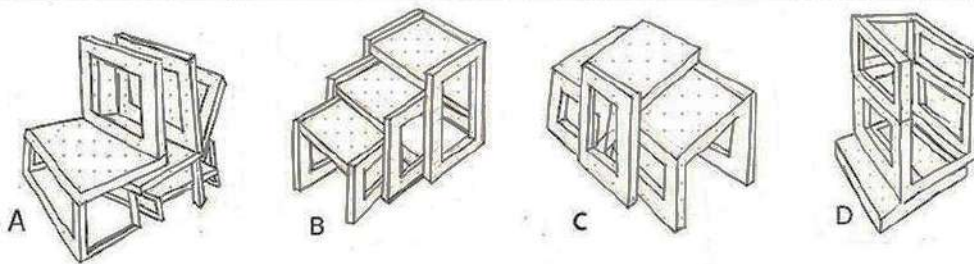
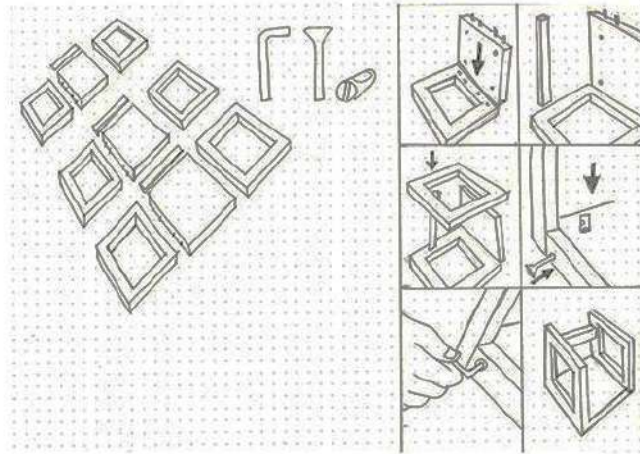

Q.55 Aru bought a new cushion cover from the market. Though the material is cotton, she was not happy with the plain cushion cover and planned to dye it with a colour. She followed the process as shown in the diagram, starting with folding the cover along the Y axis. After the first dye, she made the cushion cover dry and again did the same process, but this time started the folding along the X axis. Find out the pattern she created after the second dye.

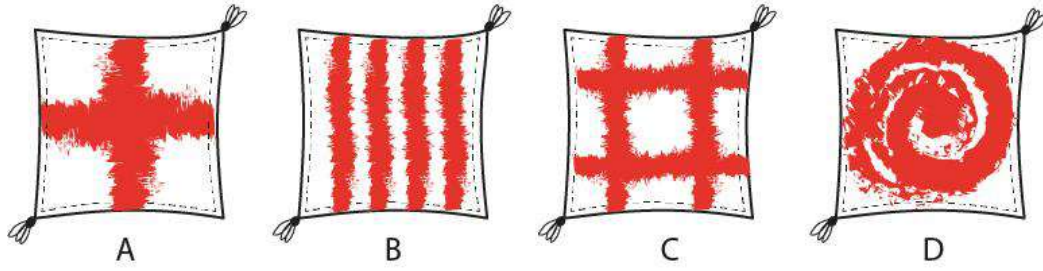
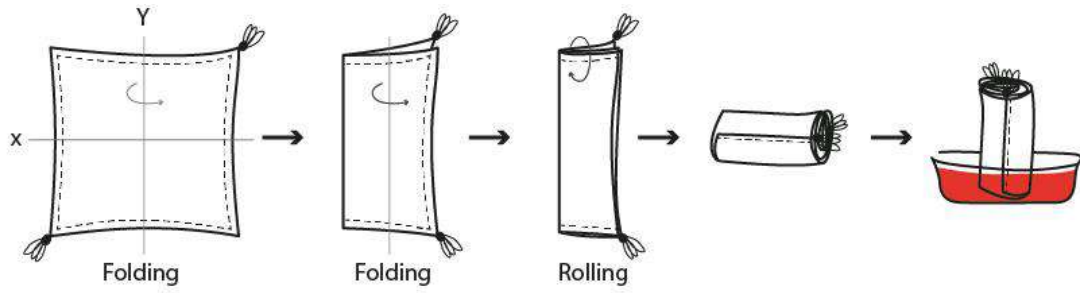

Q.56 Select the correct option which lists the animals appearing in the GIF.

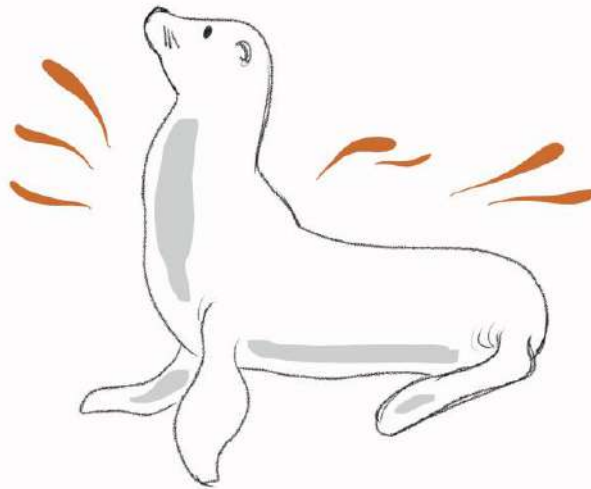

- A. Lizard, Dog, Swan
- B. Goat, Cat, Crocodile
- C. Dog, Swan, Seal
- D. Dog, Goat, lizard

Q.57 Find the exact pattern highlighted in the red square.

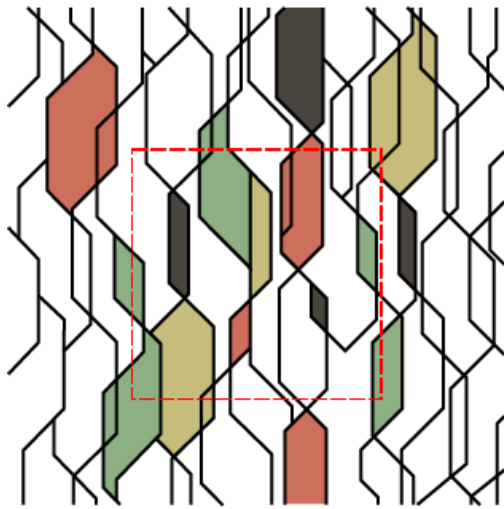

A



B



C



D

Q.58 A layout director of a newspaper was listening to music loops P, Q, R and S. Subsequently, the director created layouts 1, 2, 3 and 4 for the Music section of the newspaper. Indicate the correct pair of music loop and the layout.

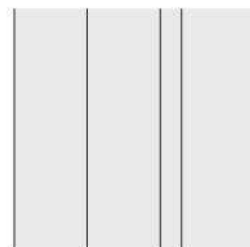
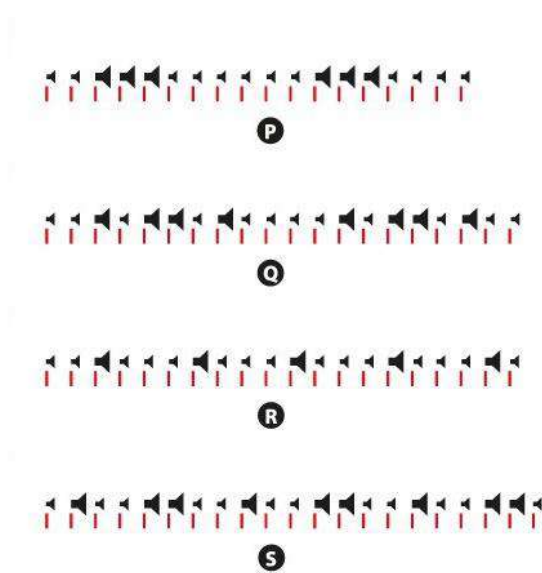

1

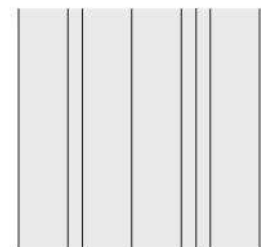

2

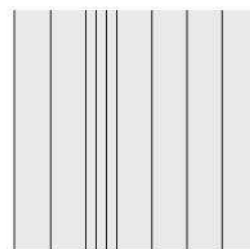

3

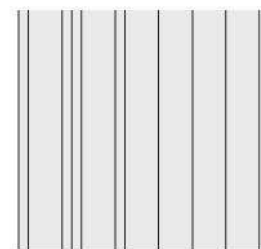

4

- A. P-4, Q-3, R-2, S-1
- B. P-2, Q-1, R-4, S-3
- C. P-3, Q-4, R-1, S-2
- D. P-1, Q-2, R-3, S-4

Q.59 Shown below is a transparent roller stamp. Identify the print made from the roller.

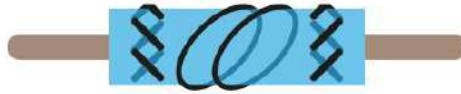

A

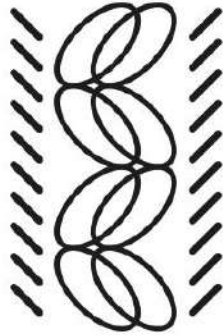

B

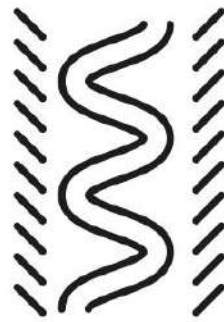

C



D

Q.60 Find the odd one.



A

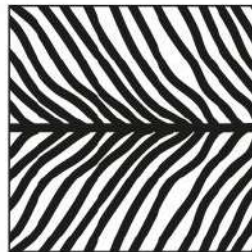

B

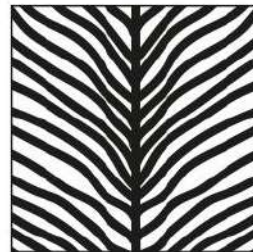

C

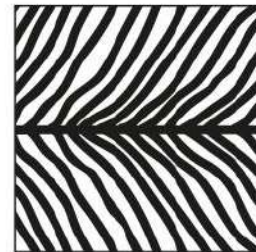

D

Q.61 Shown below are visual lines that were decoded into names.



GAUTAMA BUDDHA



VIVEKANANDA

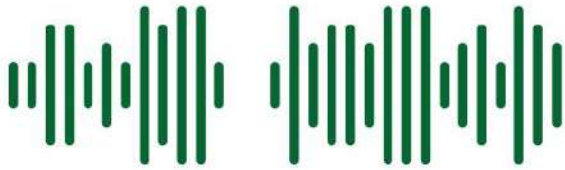

ALBERT EINSTEIN



?

- A. RAGAVENDERAN
- B. RADHAKRISHNAN
- C. RAMANABHUSHAN
- D. THIRUVALLUVAN

Q.62 Identify the side view of the spring.

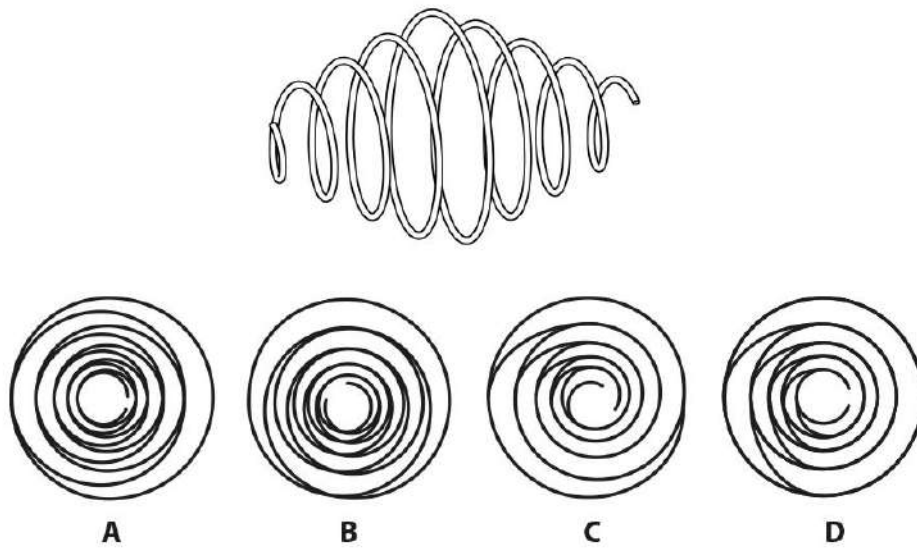

Q.63 What is the function of these objects?

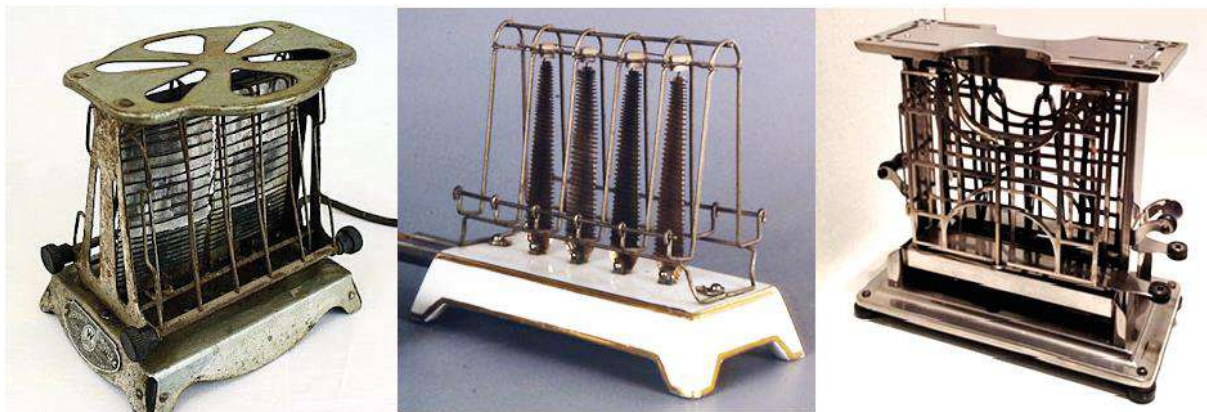

- A. Measuring earthquakes
- B. Weaving cotton
- C. Toasting bread
- D. Burning wood

Q.64 Cathy has less money than David. Cathy and David together have as much money as Alice and Bob together. Alice and David together have less money than Bob and Cathy together. What is the correct richest-poorest pairing?

- A: Bob-Cathy
- B: Bob-Alice
- C: David-Cathy
- D: Cathy-Alice

Q.65

SUGAR = ?

- A
- B
- C
- D

Q.66 Shown below is a 3D block. Four such blocks are interlocked in a square form. What will be the top view of the blocks after interlocking?

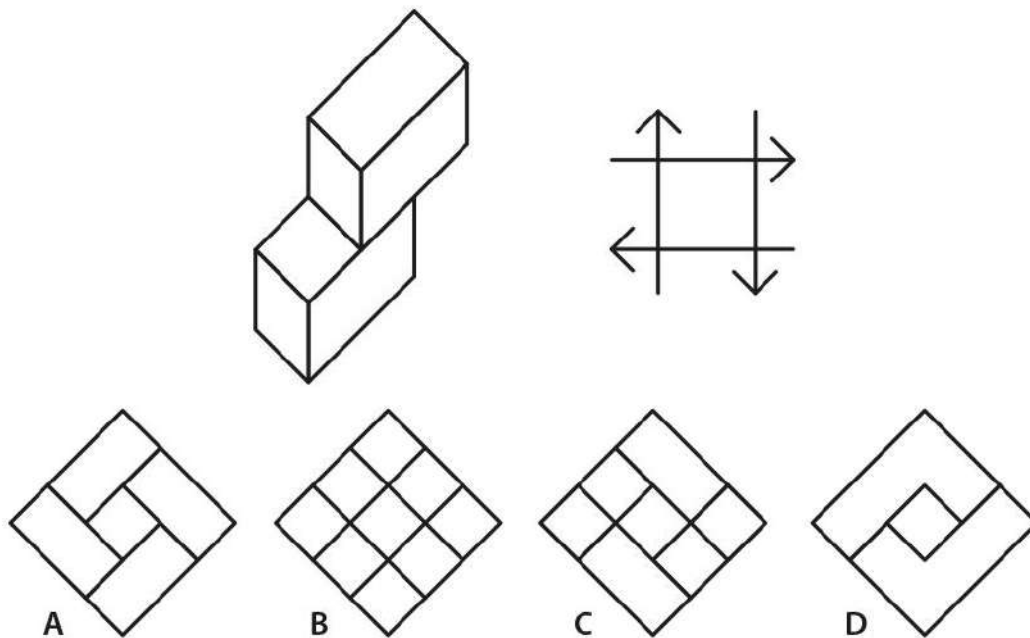

Q.67 Which betel nut cutter will require less force to be applied to cut a betel nut?
Consider the hinge points to be at the same line.



A



B



C



D

Q.68

 = **GOAT**

 = **LIZARD**

 = **TIGER**

 = **?**

- A. RAM
- B. MOTH
- C. BAT
- D. SNAKE

PART B

Sketching

(30 minutes – 60 marks)

Nandu is giving a dance exam in online mode in front of a laptop kept on a table. His mother is prompting from behind. While the exam is going on, his pet cat Poco is running around tumbling over a glass of water, a plate of biscuits and a few books. No one can stop Poco and the exam must go on. **Visualize and draw the whole situation as if you are sitting on the floor witnessing the scene.**

Note:

- Make pencil sketches only
- Do not use colours

Evaluation Criteria:

- Observation
- Imagination
- Selection & composition of objects
- Quality of lines
- Presentation
- Attention to details

UCEED 2022 - ANSWER KEY

SECTION 1 (NAT)									
Q. No.	KEY RANGE	Q. No.	KEY RANGE	Q. No.	KEY RANGE	Q. No.	KEY RANGE	Q. No.	KEY RANGE
01	14	02	32	03	836975	04	742198653	05	24
06	7	07	153.5 – 154.5	08	0.25	09	80	10	5724361
11	50	12	43	13	10	14	18	15	60
16	75	17	30	18	15				

SECTION 2 (MSQ)									
Q. No.	KEY	Q. No.	KEY	Q. No.	KEY	Q. No.	KEY	Q. No.	KEY
19	A, D	20	A, D	21	C, D	22	A, B, D	23	A, C, D
24	A, D	25	A, D	26	B, C, D	27	B, D	28	A, B
29	A, C	30	B, D	31	A, B	32	A, C, D	33	A, D
34	A, D	35	A, B	36	A, C				

SECTION 3 (MCQ)									
Q. No.	KEY	Q. No.	KEY	Q. No.	KEY	Q. No.	KEY	Q. No.	KEY
37	A	38	B	39	D	40	D	41	D
42	C	43	A	44	C	45	A	46	D
47	C	48	C	49	D	50	A	51	A
52	A	53	B	54	A	55	C	56	B
57	D	58	A	59	A	60	C	61	B
62	C	63	A	64	B	65	B	66	B
67	D	68	B						

Undergraduate Common Entrance Examination for Design

UCEED 2022

Question Paper

PART-A

Section 1: Numerical Answer Type (NAT) questions

Section 1 (72 Marks) of Part-A contains a total of 18 **Numerical Answer Type (NAT)** questions. For each question, the answer is a real number that needs to be entered using the virtual keyboard on the monitor. Questions from 1 to 18 belong to this section.

- Q.01** A solid square pyramid has triangular cut-outs that pass through and through, as shown in the figure. How many surfaces are there in the resultant solid?

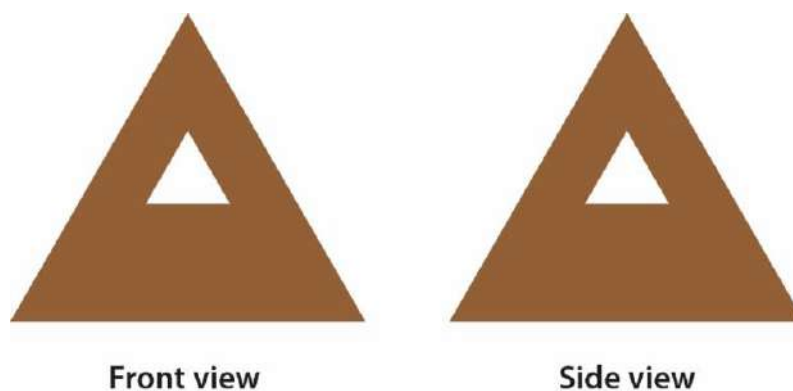

- Q.02** The figure shows different paths for going from A to B. The directions of the paths are indicated by arrows. No node can be visited twice. What is the total number of different paths to go from A to B?

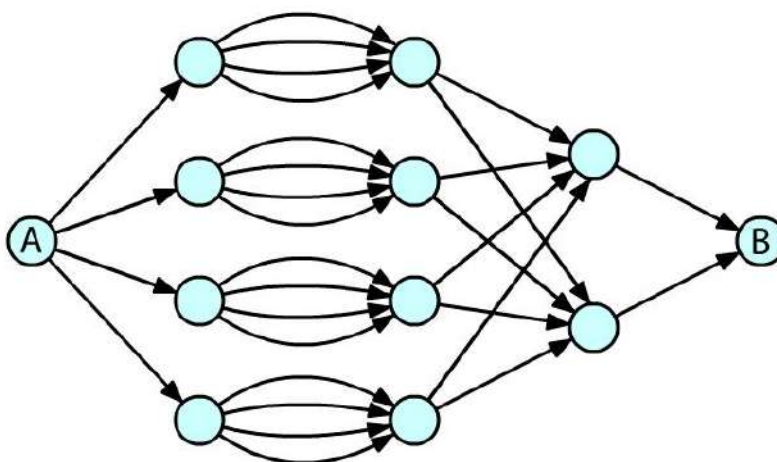

Q.03

FF1+1NF=ART

1F\1+1\J1=TEXT

FJL7^c+c\PPFL=?

Q.04 Shown below is a book shelf that has a kid's adventure novel in a book series of 9 volumes. The spines (binding side) of these books contain parts of a treasure map. What is the sequence of the books that forms the completed treasure map? Enter the answer as a single nine-digit integer.

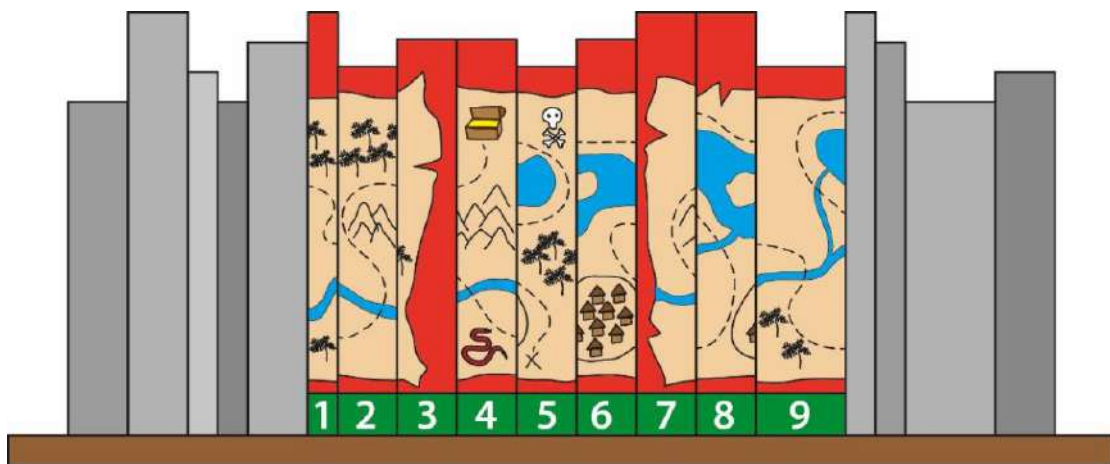

Q.05 Perform the following steps:
 Step 1: Start with $x=1, y=2$
 Step 2: Replace x by x multiplied by y
 Step 3: Replace y by $y+1$
 Step 4: If $y=5$, then go to Step 6, otherwise go to Step 5
 Step 5: Go to Step 2
 Step 6: Stop
 What is the value of x ?

(The following question contains an [animated GIF image](#))

Q.06 The animation depicts morphing of faces and abstract forms. A face consists of two eyes, two ears, a nose and a mouth. How many unique faces appear in this morphing animation?



Q.07 If $SQ = QR = RS = SP = PQ$ and $PR = 21$ units, what is the area of the BLACK portion?
(Assume $\pi = 22/7$)

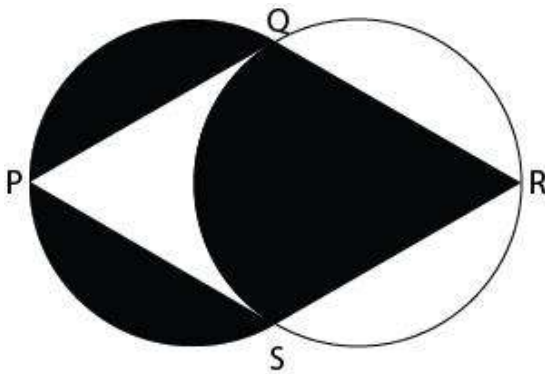

Q.08 A circle and a semicircle are inscribed in a square as shown below. What fraction of the area of the square is the blue shaded area?

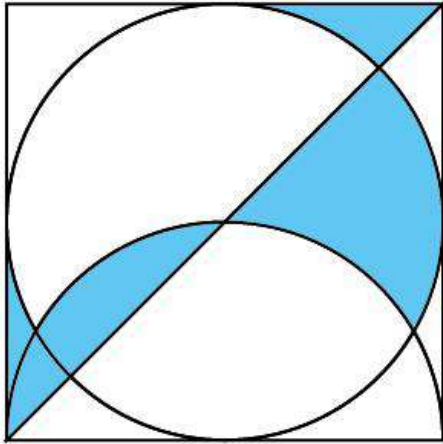

Q.09 A total of 200 people were surveyed for newspaper readership. It was found that 100 people read publication X, 120 people read publication Y and 50 people do not read either X or Y. What is the total number of people who read either publication X or publication Y but not both?

Q.10 Row 1 shows a word with 7 partial letters. Row 2 contains the parts that complete the word in Row 1. The parts in Row 2 are arranged randomly. What should be the correct sequence in Row 2?

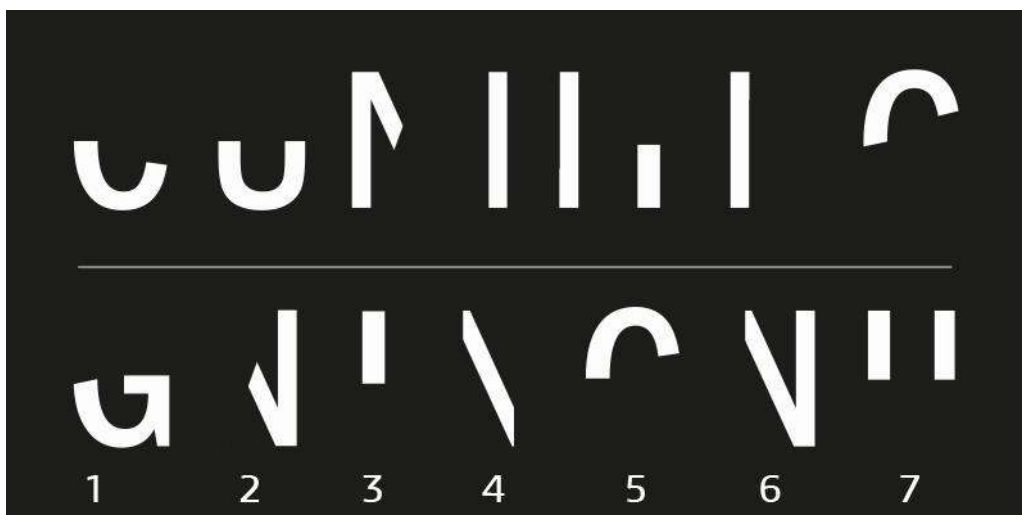

- Q.11** A square of side 10 units, shaded in yellow, is cut using a square of side 5 units as shown in the figure. What is the perimeter of the resulting shape, shaded in yellow?

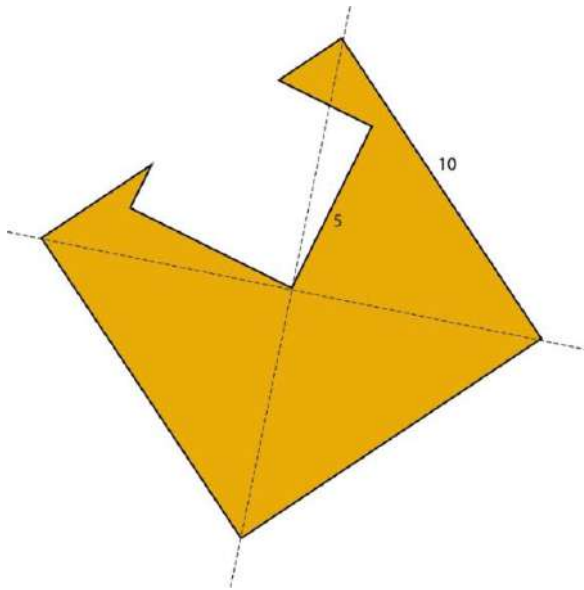

- Q.12** X is three times as old as Y was three years ago. After 17 years, Y will be as old as X is today. What is the sum of the ages of X and Y today?

- Q.13** Shown below are three tubes P, Q and R with coloured marbles. Each tube can hold a maximum of 5 marbles. Only one marble can be transferred in a move. What is the minimum number of moves required to transfer the red marble from tube 'P' to the bottom of tube 'R'?

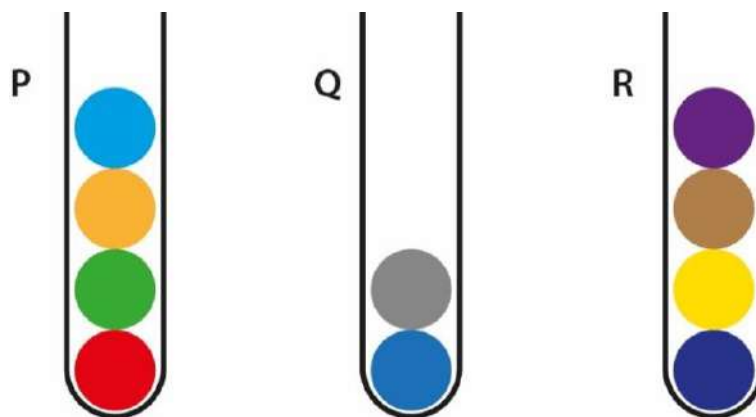

Q.14 How many right-angled triangles are there in the image?

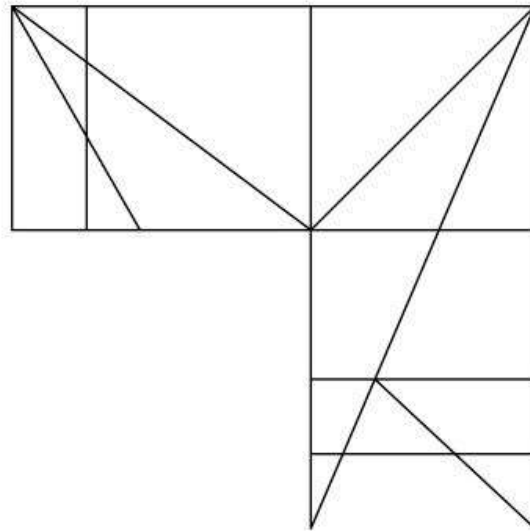

Q.15 The image shows a hanging sculpture created by tying fish-shaped cutouts of different weights by blue strings on brown sticks, as shown. The sticks and strings have negligible weight. The sculpture remains balanced after it is suspended from a ceiling. If the weight of the black fish is 5 grams, what is the weight (in grams) of the red fish?

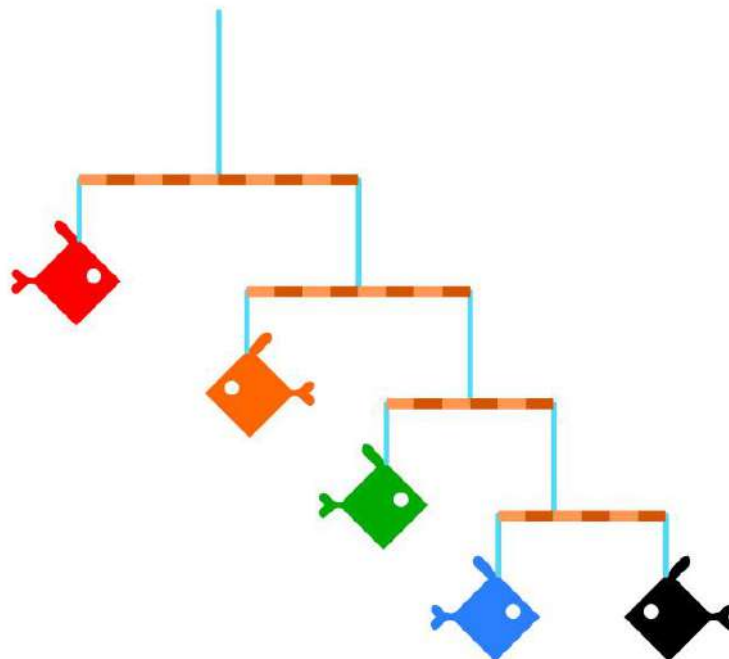

- Q.16** A system of gears and belts is shown below. The diameters of the gears M, N, P, Q, R and S are 3, 1, 2, 1, 3 and 2 meters respectively. If the gear M is rotating at 100 rpm, what is the rpm of gear S?

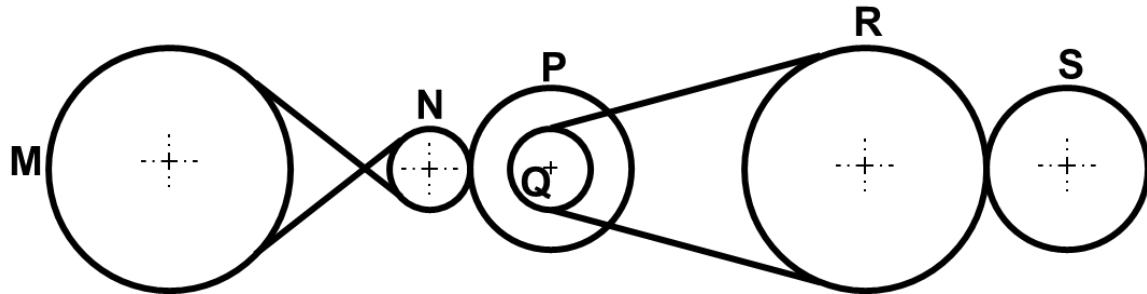

- Q.17** The given 3D object is made by combining three shapes - pentagons, squares and triangles. What is the total number of squares?

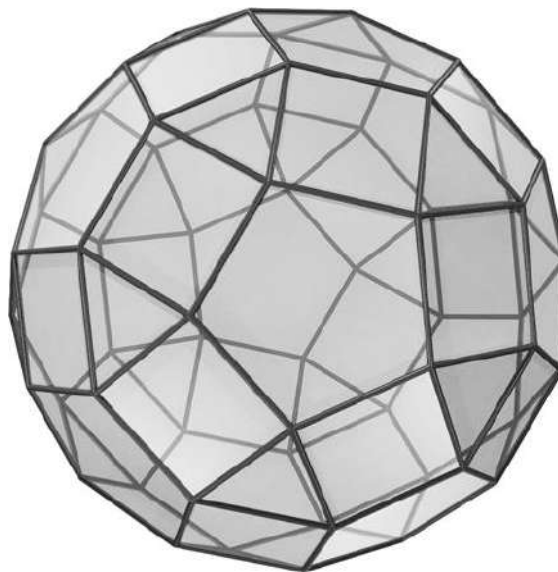

Q.18 The perimeter of the equilateral triangle and the regular hexagon shown in the figure are equal. The circumference of the red circle inscribed in the triangle is 10 cm. What is the circumference of the blue circle inscribed in the hexagon?

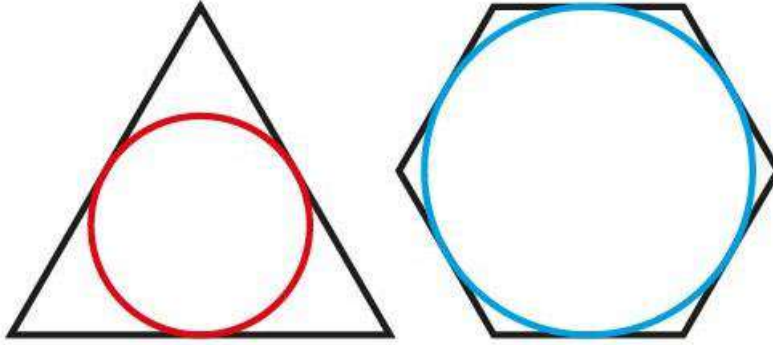

Section 2: Multiple Select Questions (MSQ)

Section 2 (72 Marks) of Part-A contains a total of 18 **Multiple Select Questions (MSQ)**. Each question may have **one or more than one correct choice(s)** out of the four given. Questions from 19 to 36 belong to this section.

Q.19 Shown on the left is a pattern printed by repeated use of a single printing block. Which of the printing blocks shown on the right can be used to print the pattern?

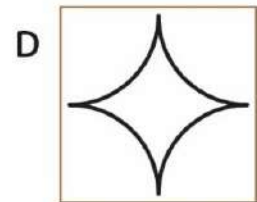
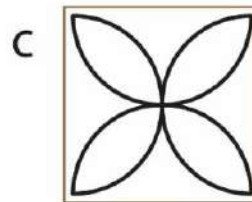
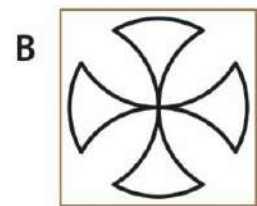
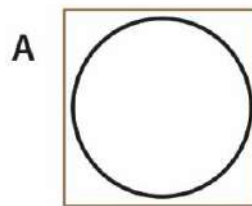
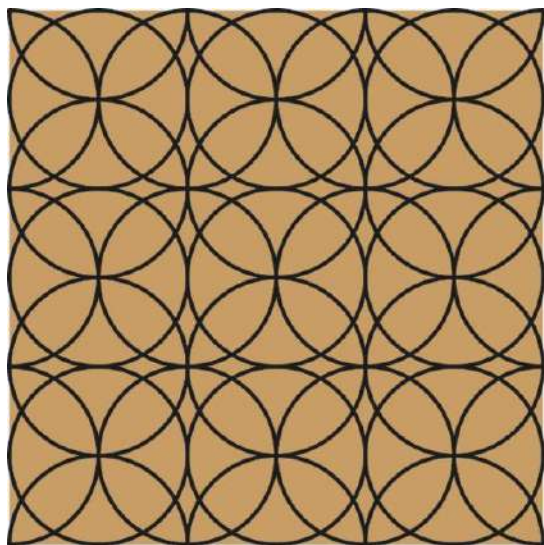

Q.20 Shown on the left is a socket with four holes in it. Which of the plugs will fit perfectly in this socket?

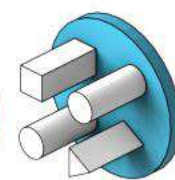
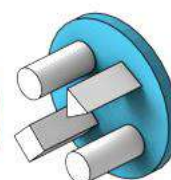
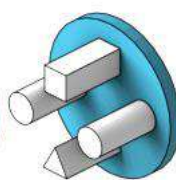
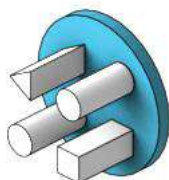
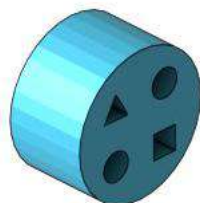

Q.21 Which of the options show parts of the graph representing the equation $x^y = 25$?

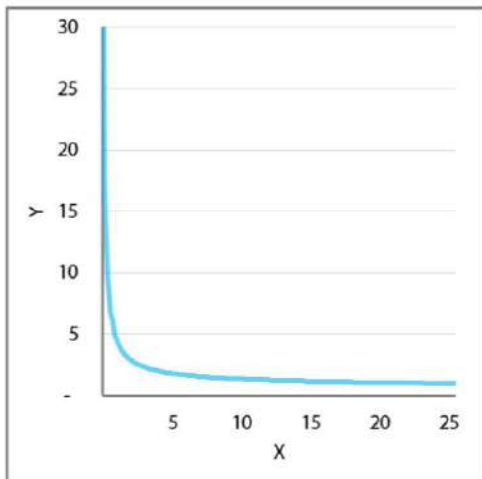

A

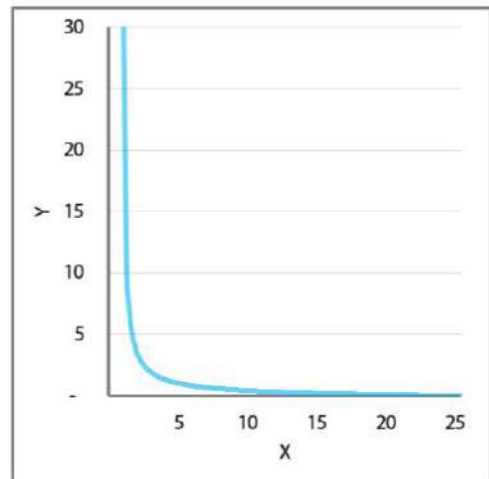

B

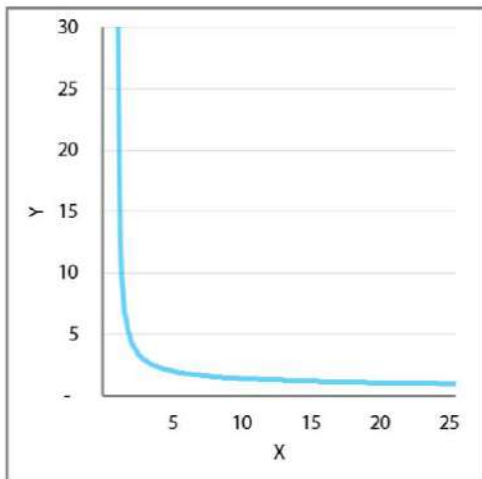

C

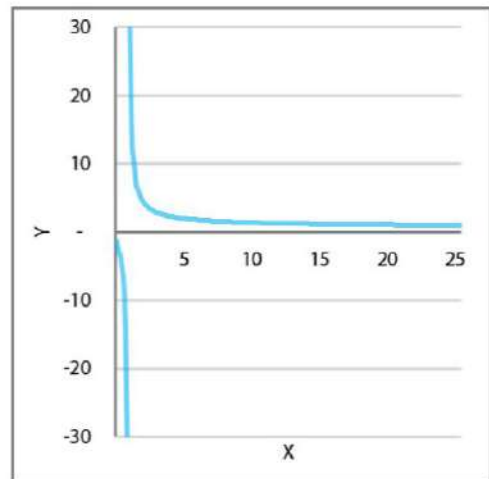

D

Q.22 Which of the given figures can be drawn without lifting the pen? The lines can cross each other but cannot overlap on top of one another.

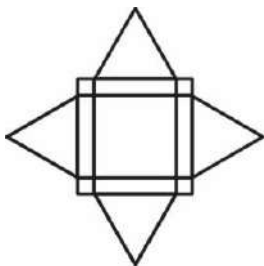

A

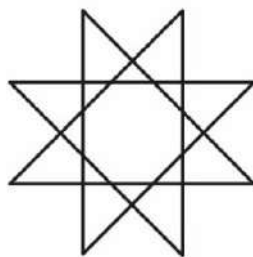

B

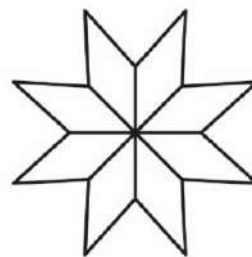

C

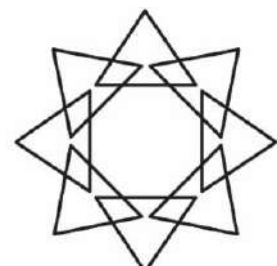

D

Q.23 Shown below are 2 views of the same solid. Through which of the cutouts shown in the options, will the solid pass?

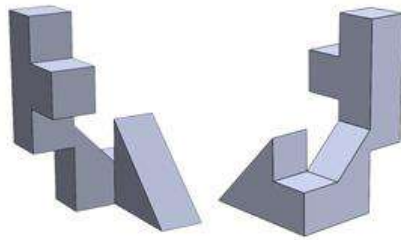

A

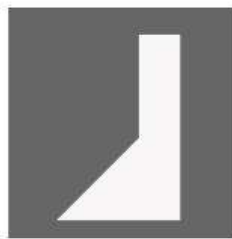

B

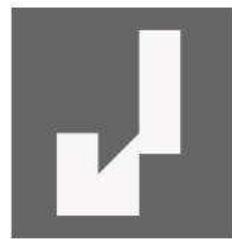

C



D

Q.24 Shown below are different forms for a step-stool. Which of the forms will remain stable when a person is standing on the top step?



A



B



C



D

Q.25 Tile X was used to create a pattern which is seamless (without gaps), when arranged as shown in Y. Which of the tiles from the options will create a seamless pattern?

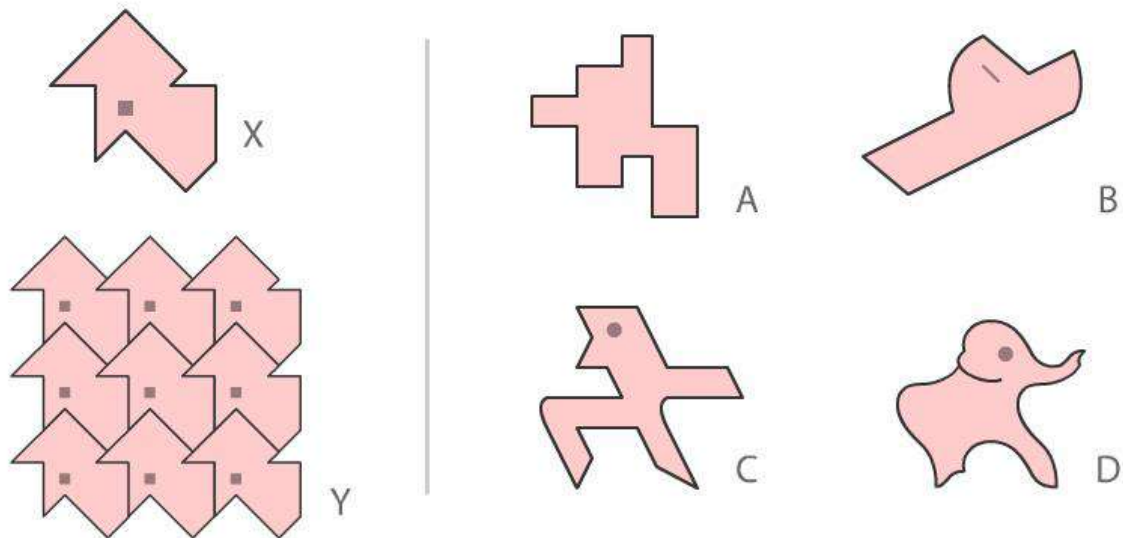

Q.26 A painted solid is shown from two different directions. Which of the options can be the same solid seen from another direction?

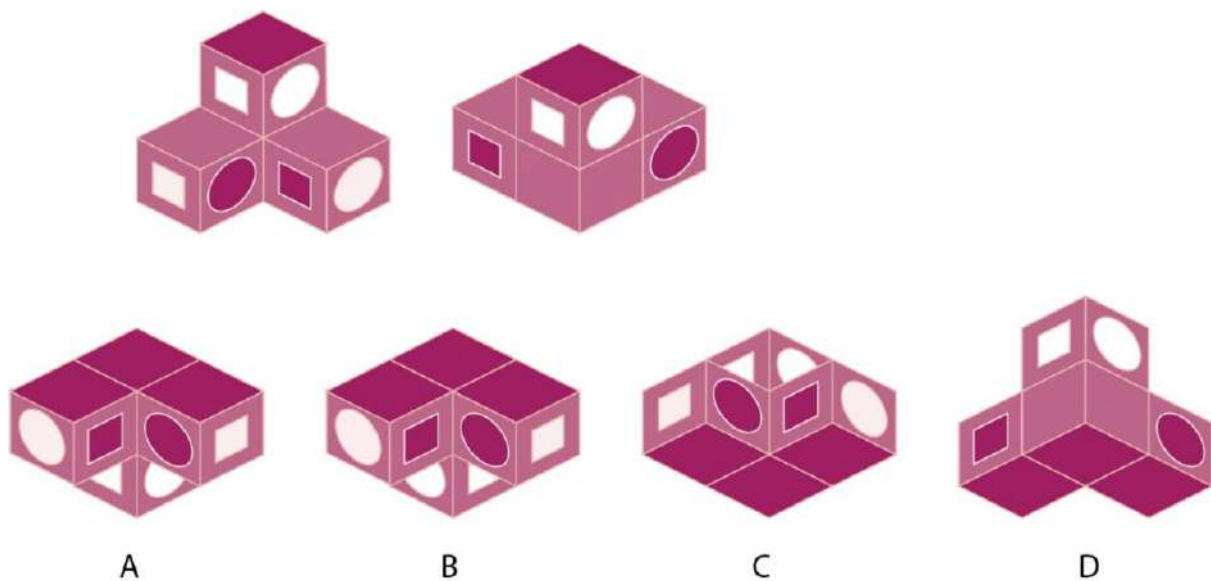

Q.27 Which of the options will form a knot when both the ends are pulled outward?

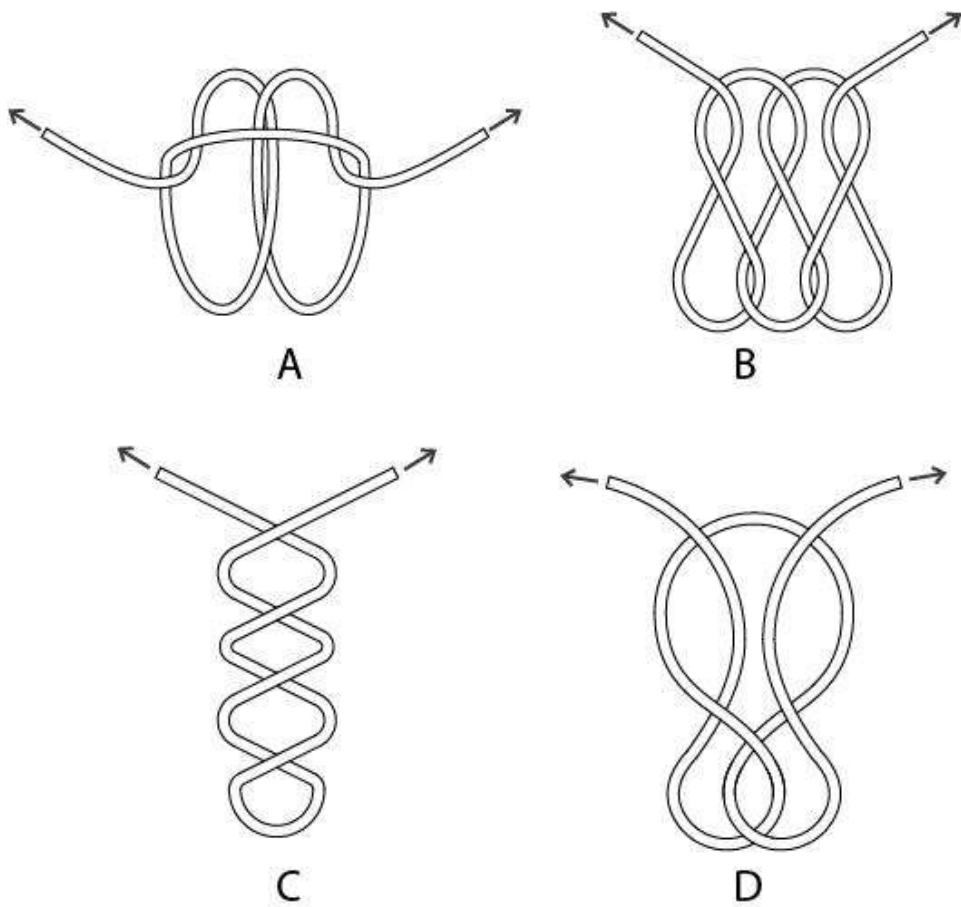

Q.28 Figure P can be created by tiling 4 identical pieces. The pieces should not overlap while tiling. Which of the pieces shown in the options can be used to create figure P, assuming that you can rotate and flip them?

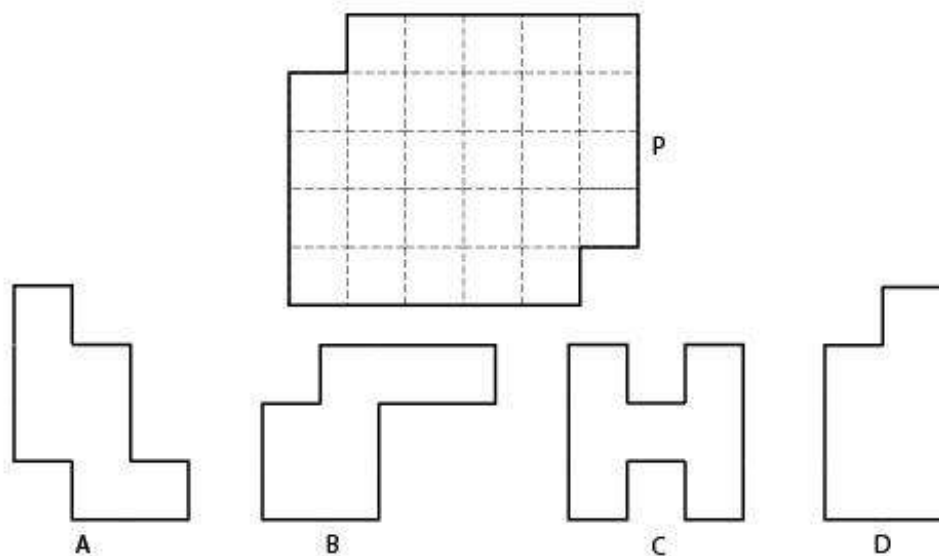

Q.29 Shown below is an isometric view of a cuboidal glass container of size 2 X 2 X 3 units. It contains a solid wooden block and some water. When tilted, which of the options will be the side view(s) of the glass container?

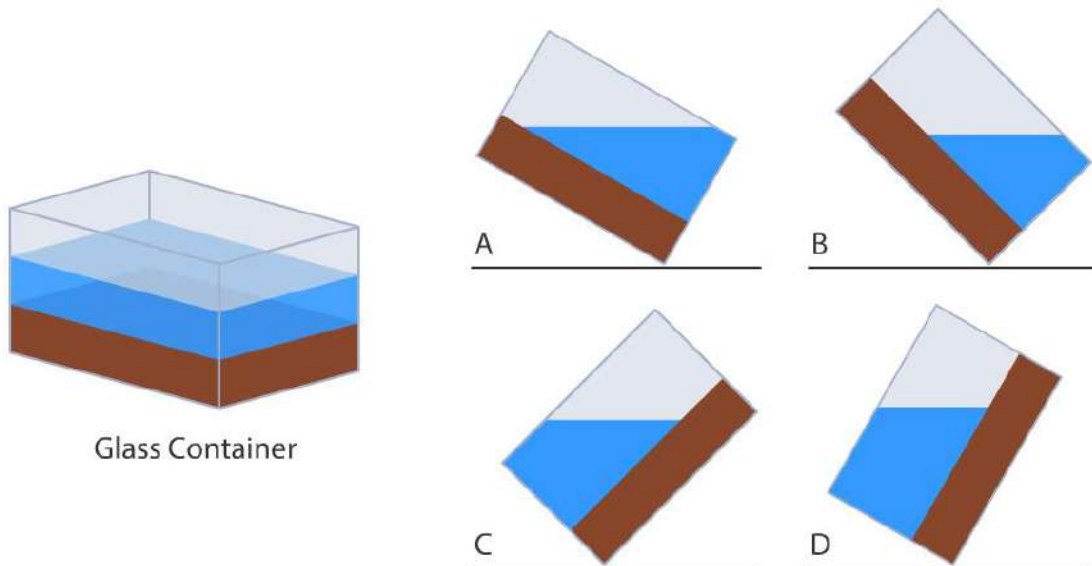

Q.30 Four solid pieces P, Q, R and S are arranged to form a cube. Which of the cubes shown in the options is/are **NOT** possible?

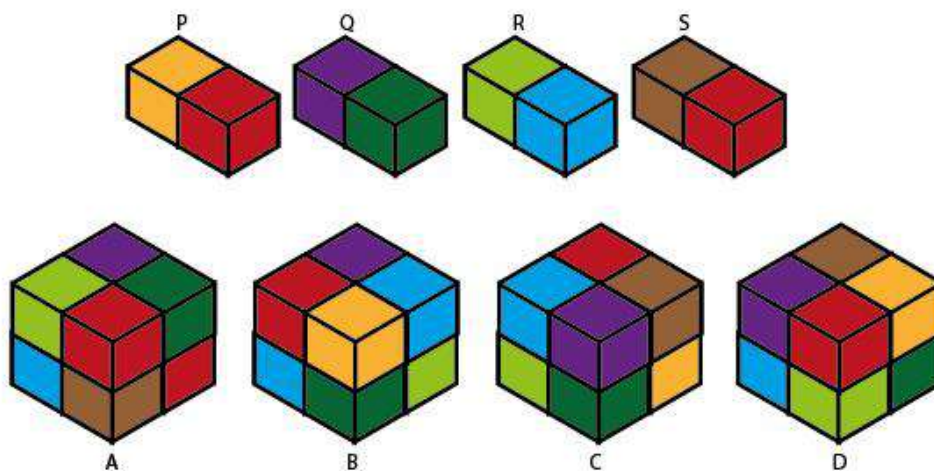

Q.31 A contractor has a set of ceramic tiles of which one tile is shown on the left. Which of the options show(s) the pattern(s) created using this tile?



Ceramic Tile

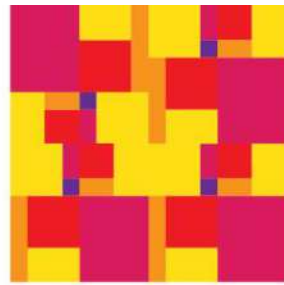

A

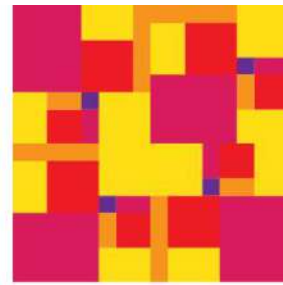

B

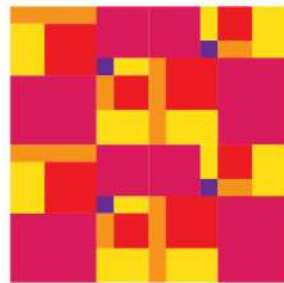

C

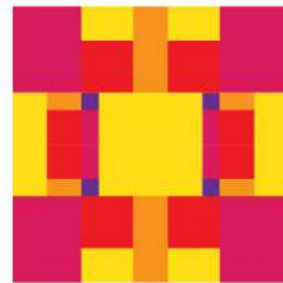

D

Q.32 Which of the options can be made using all the four pieces shown in the top row? Flipping the pieces is allowed.

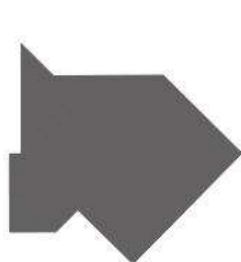
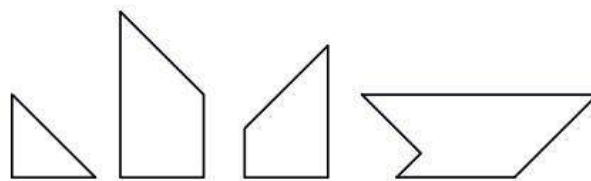

A



B

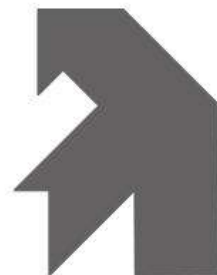

C



D

Q.33 A puzzle board can be covered completely using puzzle pieces, six of which are shown below. Which of the pieces in the options can be used along with these six pieces to cover the board completely? Flipping and rotating of the pieces is allowed. Overlapping of the pieces is NOT allowed.

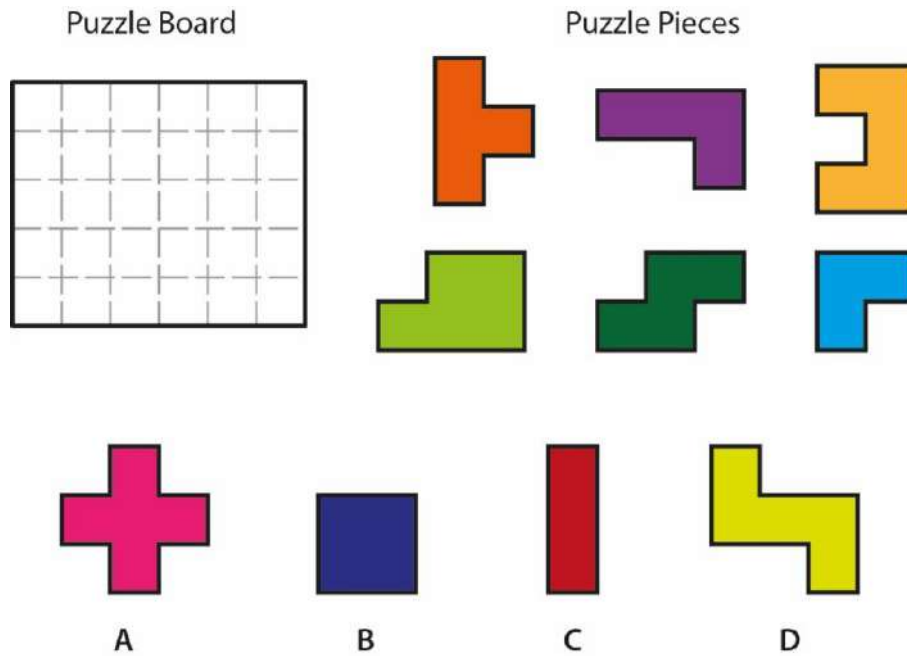

Q.34 Which of the chairs will rock TO AND FRO?

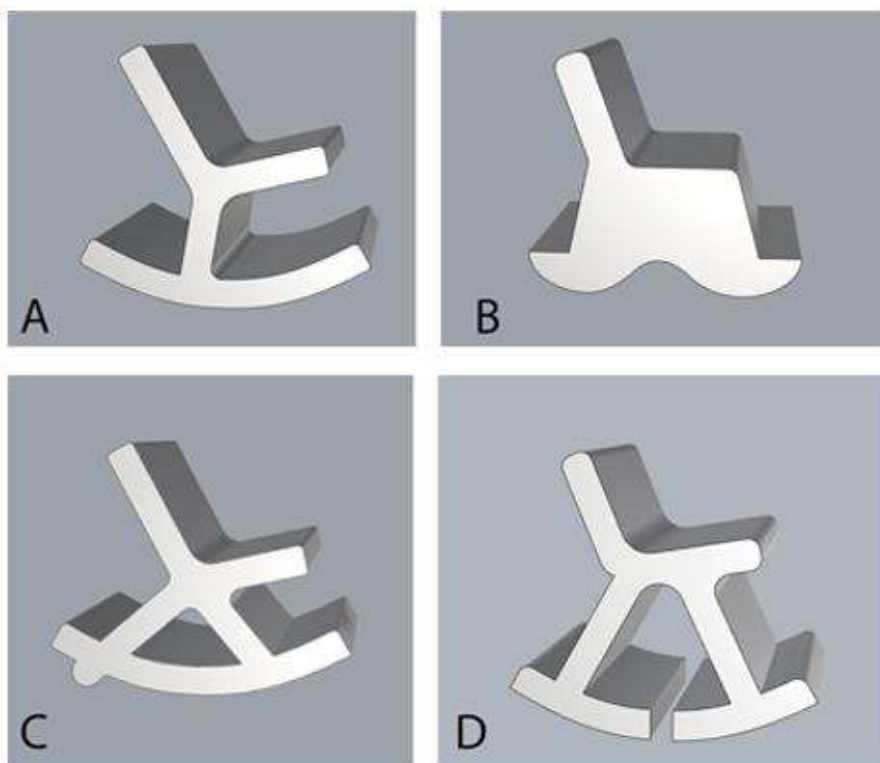

Q.35 Which of the options is/are simple rotation(s) of the image P?

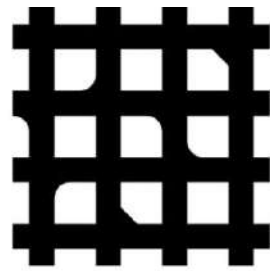

P

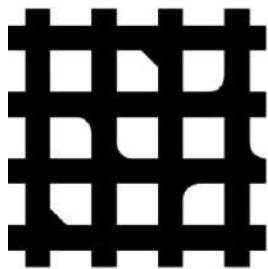

A

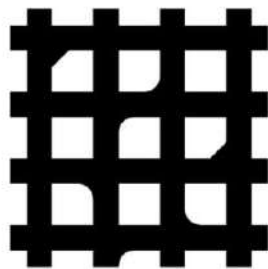

B

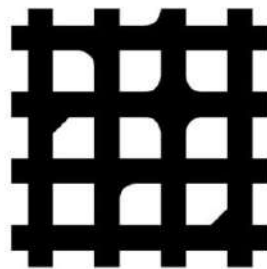

C

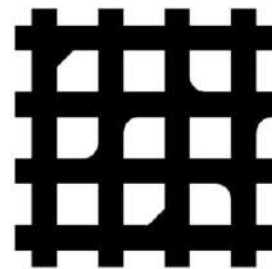

D

Q.36 Shown on the left is the development of a cube. Which of the options can be created when the shown development is folded?

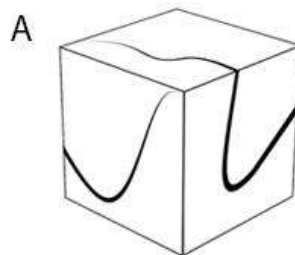
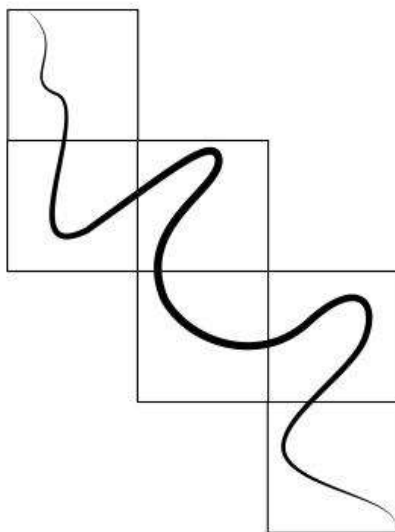

A

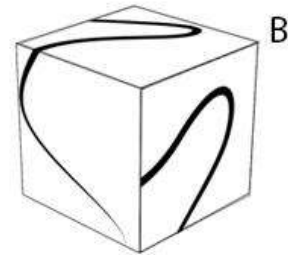

B

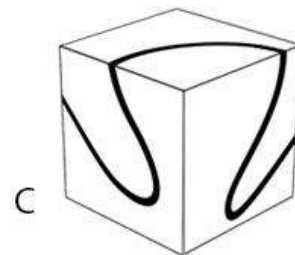

C

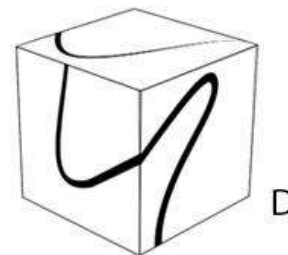

D

Section 3: Multiple Choice Questions (MCQ)

Section 3 (96 Marks) of Part-A contains a total of 32 **Multiple Choice Questions (MCQ)**. Each question has four choices out of which **ONLY ONE** is the correct answer. Questions from 37 to 68 belong to this section.

Q.37 Three paper clips are attached to a paper as shown on the left. Which of the options shows the back side of the paper?

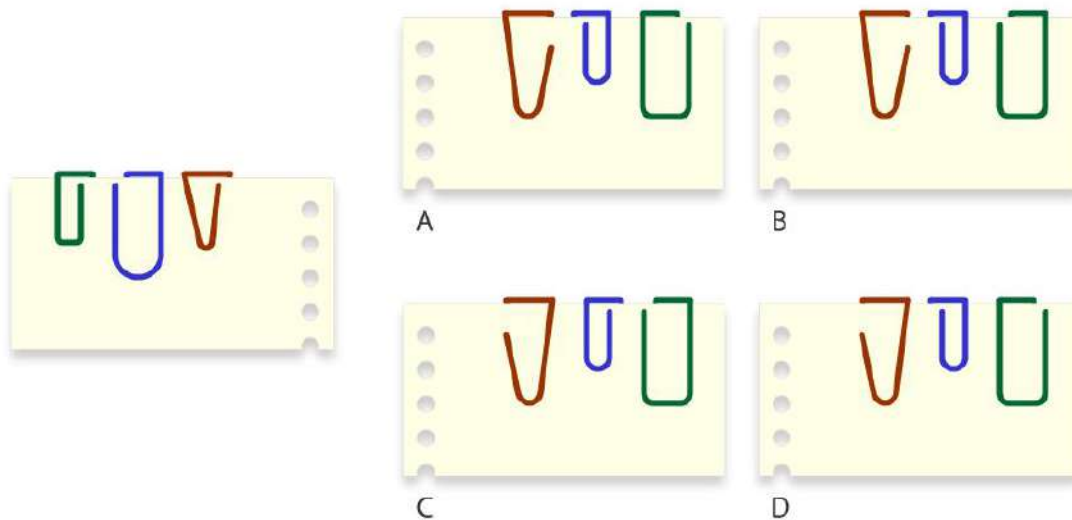

Q.38

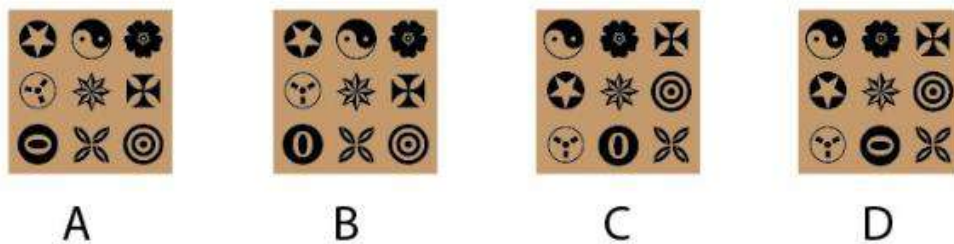
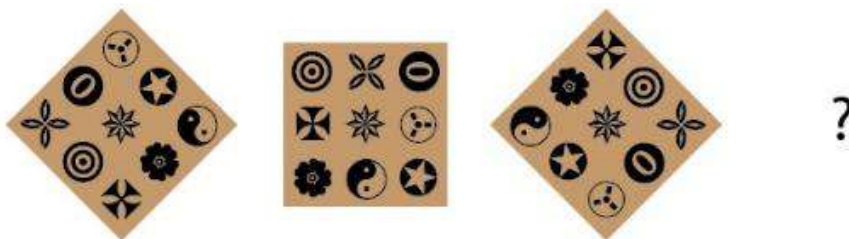

(The following question contains an [animated GIF image](#))

Q.39 An animation of revolving circles is shown on the left. If it is flipped horizontally and then flipped vertically, what will be the resulting animation?

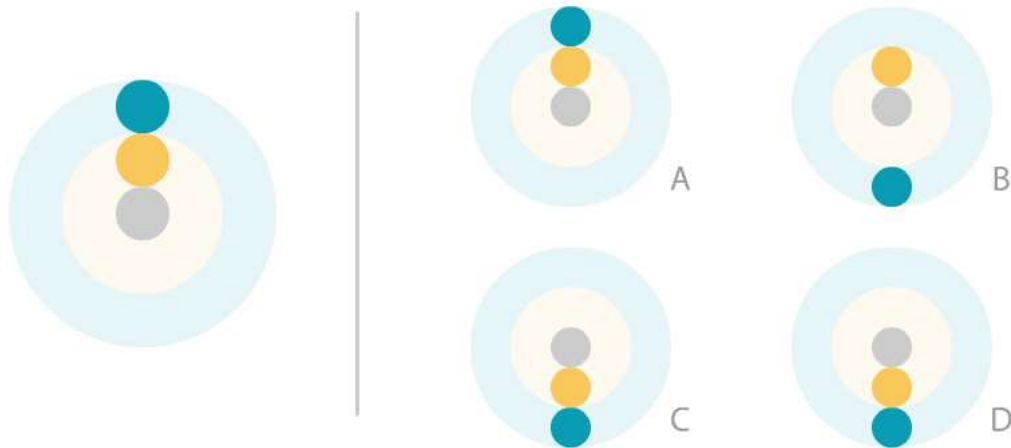

Q.40 You can set preferences in a mobile app by making a series of selections. You want to be notified of promotions and transactions, but do not want to receive newsletters. You want to allow access to your location and mic, but do not want to allow access to your contacts. What is the correct sequence of actions?

- Do not notify me on Promotions
- Send me Newsletter
- Notify my Transactions
- Do not allow access to my Contacts
- Allow access to my Location
- Allow access to my Mic

- A. Check, skip, check, check, skip, check
- B. Skip, Skip, check, skip, check, check
- C. Check, skip, skip, skip, check, check
- D. Skip, skip, check, check, check, check

Q.41 A story depicts Sabina encountering a spider. The continuing scene has to represent the spider's point of view of Sabina. What is the most appropriate option?

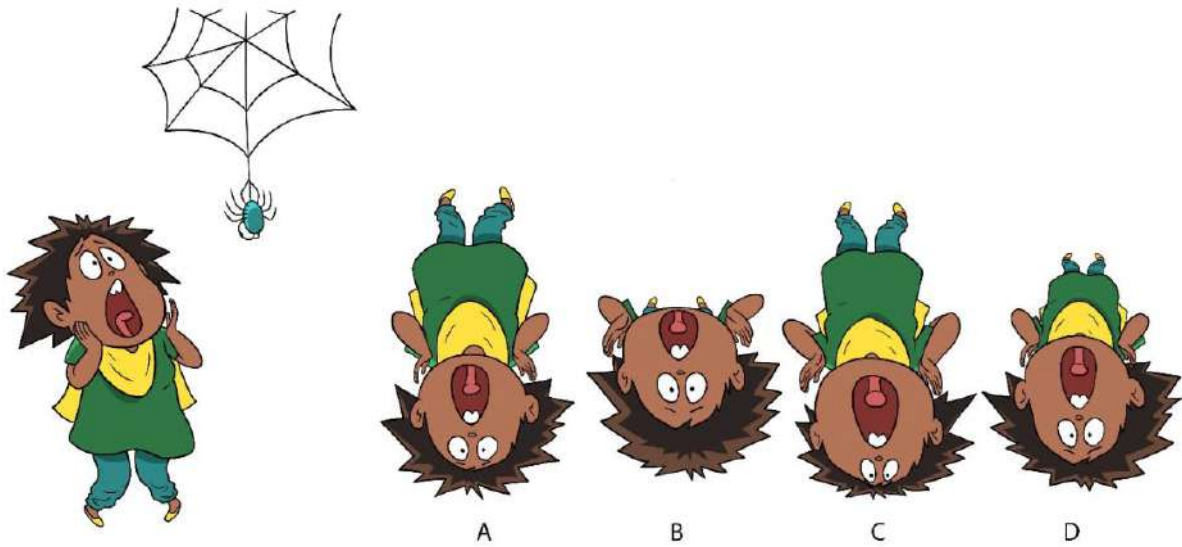

Q.42 Which option is the correct mirror image of the figure given on the left?

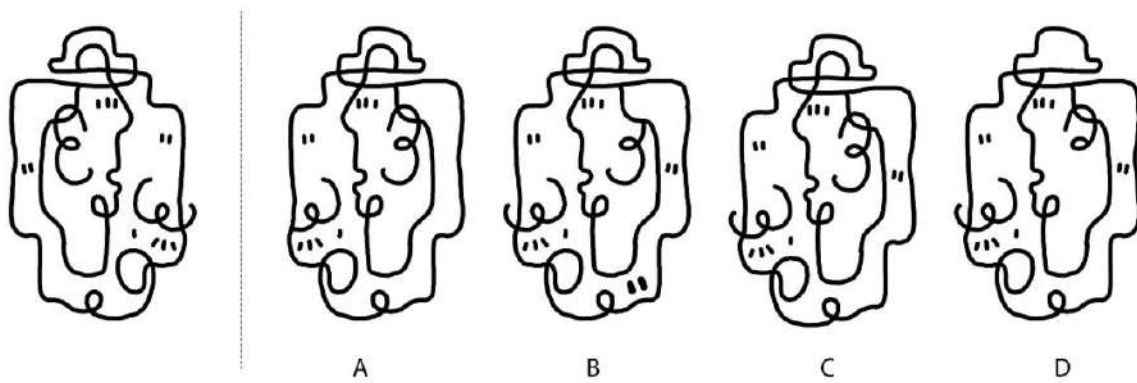

Q.43 A solid sphere is kept on a planar surface. Parallel rays of light are falling on it as shown in the image. Which option correctly represents the shadow cast by the sphere on the planar surface?

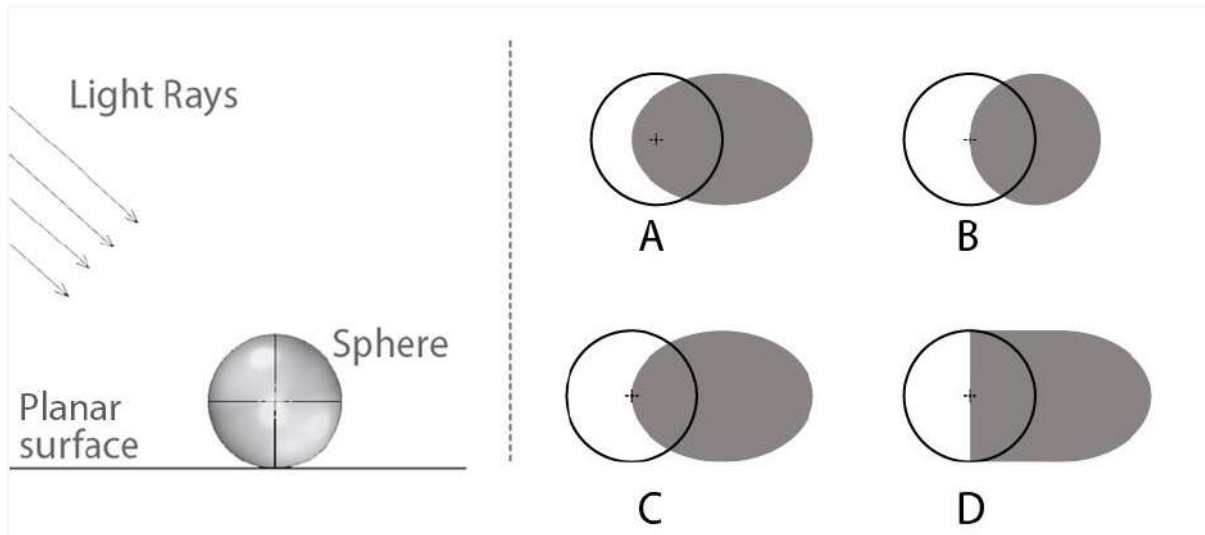

Q.44 Four students were given a task to design a stencil for the word 'pedagogy' for spray painting. Shown in the options are designs of each student that are to be cut into stencils for painting. Identify the design that will **NOT** work as a stencil to paint the given word?

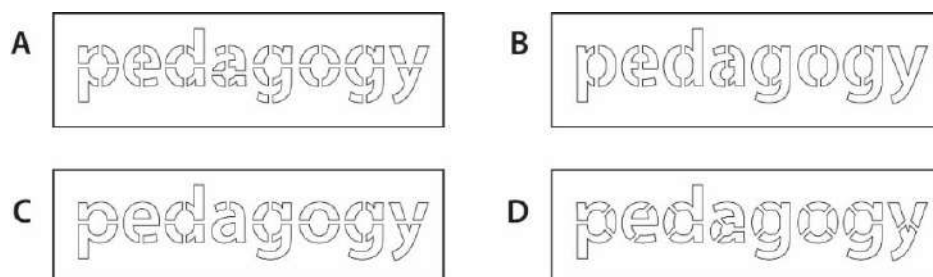

Q.45 A group of friends are on a trek. The sunlight is directly above them. No other light source is present. Identify the most appropriate lighting for this scene.



A



B



C



D

Q.46 Identify the odd one.

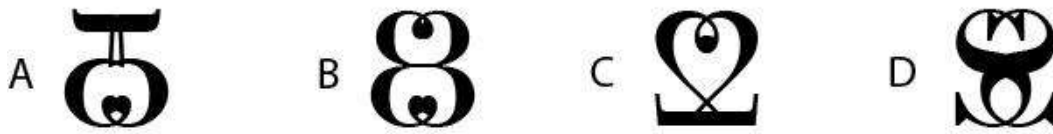

Q.47 Shown below are the 2 views of a cube. If face P is opposite to 1, Q is opposite to 2 and R is opposite to 3, which option can be folded to make the cube?

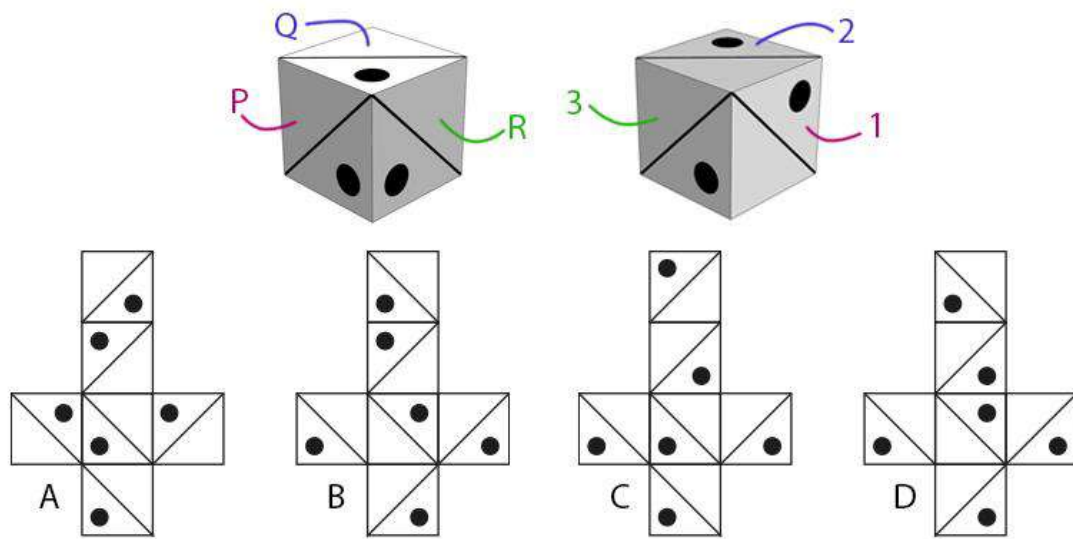

Q.48

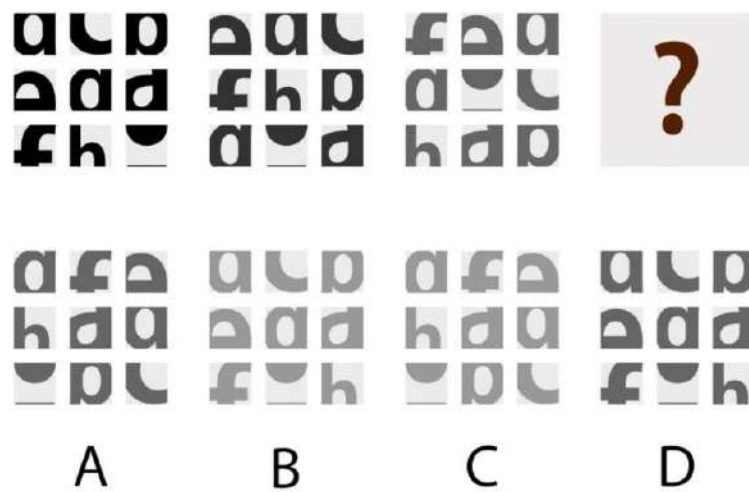

Q.49 The options show maps of some states of India. In only one of the options, the map has been scaled (either up or down). Which is that option?

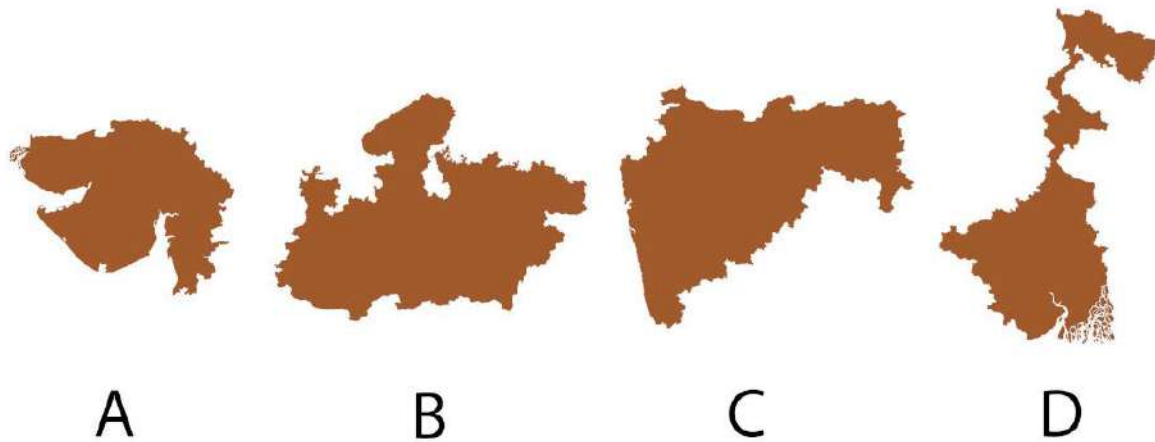

Q.50 Gita placed some objects on a white plate. She took a photo with a camera. Without disturbing the arrangement of objects, she took two more photos while turning the plate. Soon after, Shefali placed same objects on a similar plate and under similar lighting conditions, took a photo. Which option shows Shefali's photo?

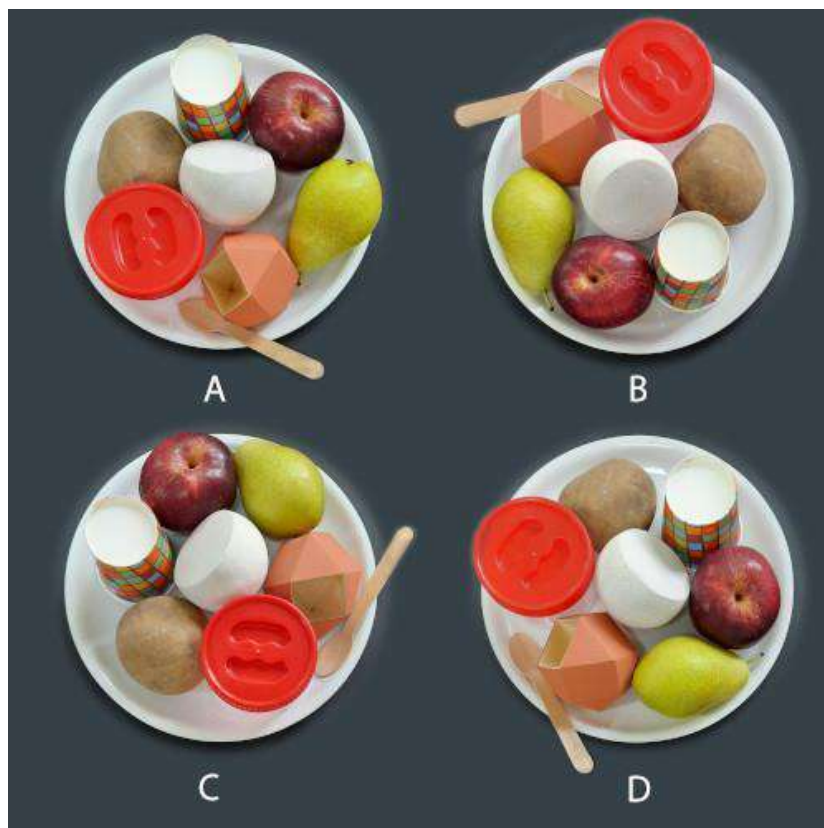

Q.51 Two views of the same object are shown in the box. Which option depicts the same object?

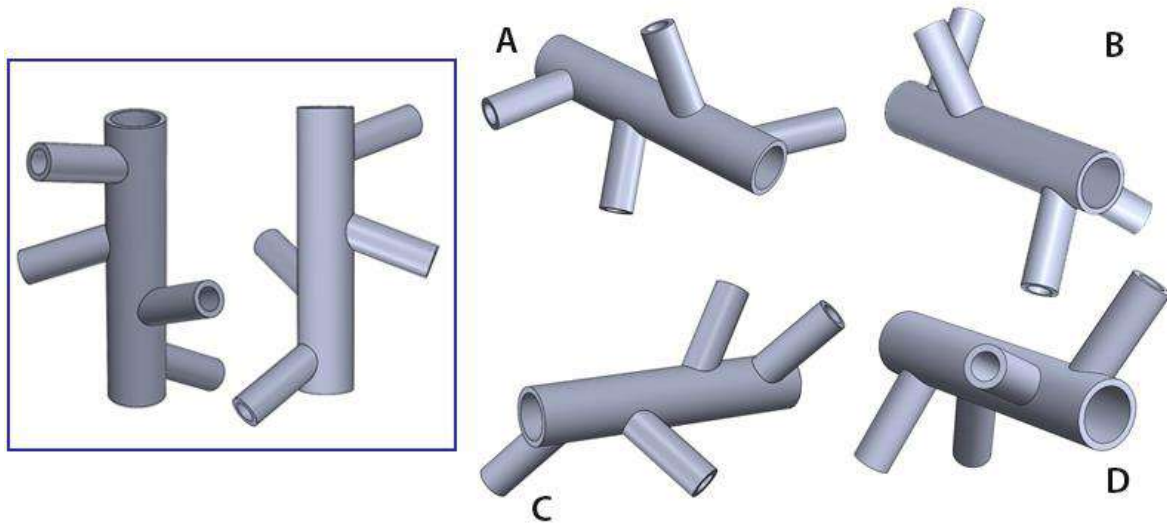

Q.52 The image shown below is made up of triangles only, from which the central portion is missing. Identify the missing portion.

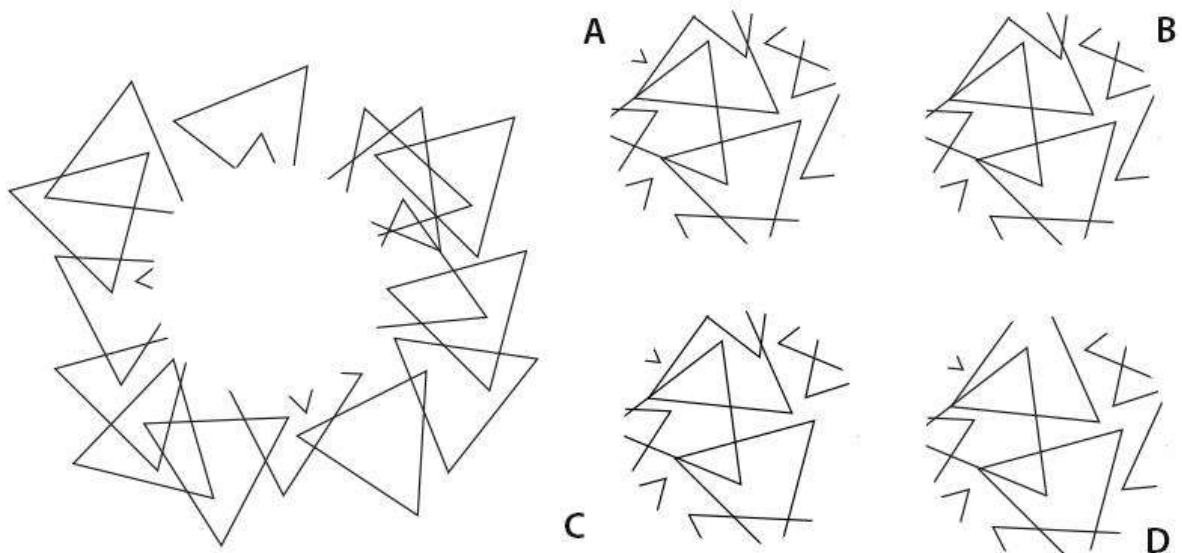

Q.53 The figure shown below is mirrored along the axes P, Q, R, S, T and U. What would be the resultant figure?

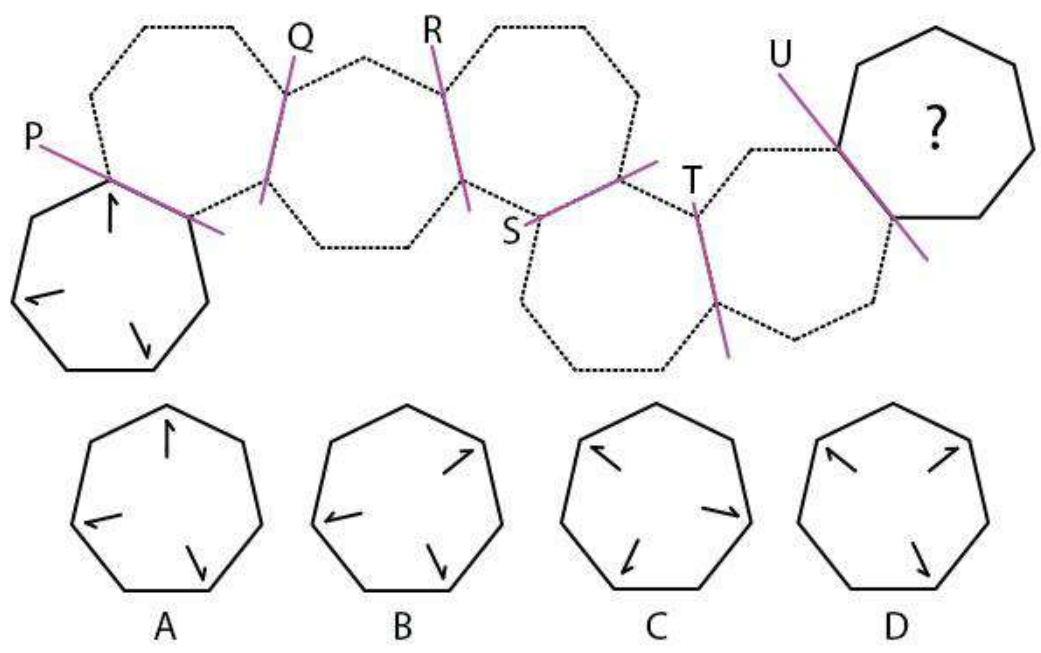

Q.54

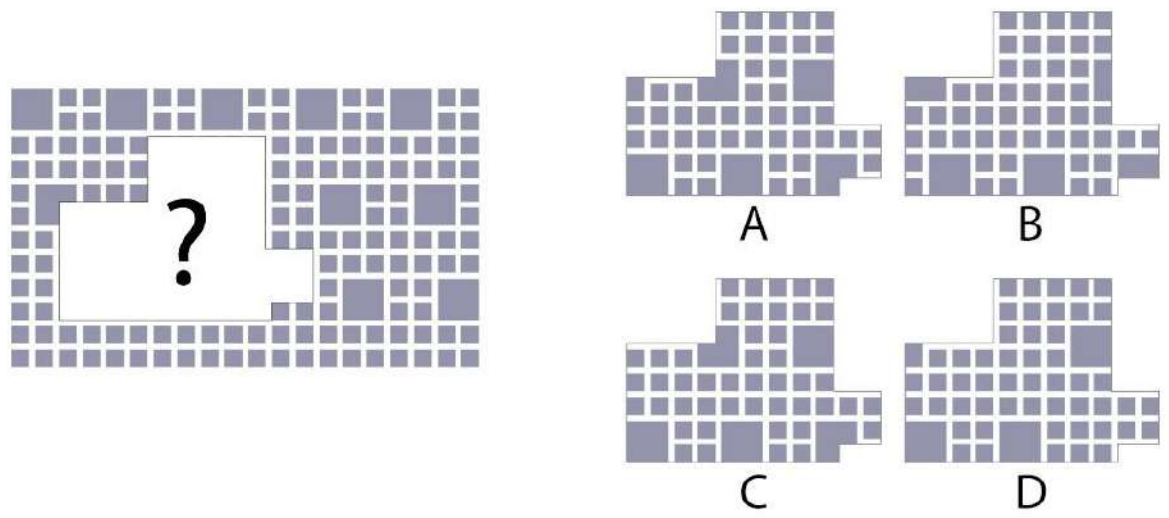

Q.55 An A4 size paper is cut as shown below and folded across the dotted lines such that it has eight faces named from 'P' to 'W'. It is further folded to make a small booklet for the purpose of a zine design. From the given options, select the correct sequence of pages.

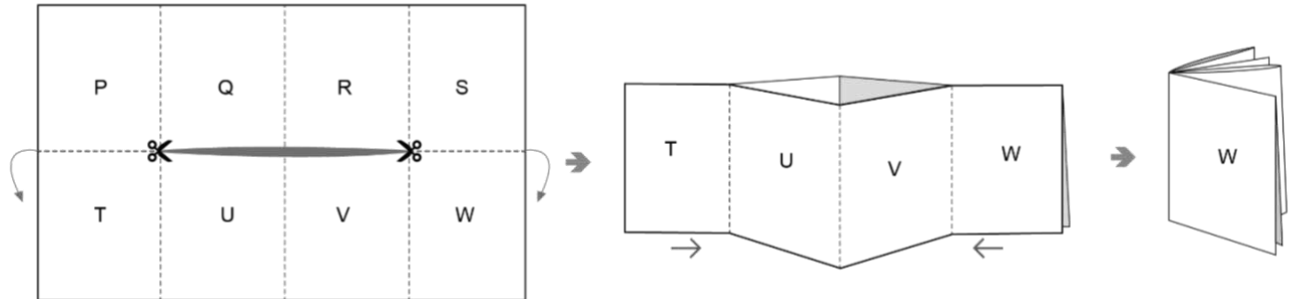

- A. P, Q, R, S, T, U, V, W
- B. W, S, R, V, U, Q, P, T
- C. W, S, R, Q, P, T, U, V
- D. W, V, U, T, S, R, Q, P

Q.56 The left image below shows Nandu's study room. The image is sliced in 9 equal parts. From the given options, find the correct set of images.

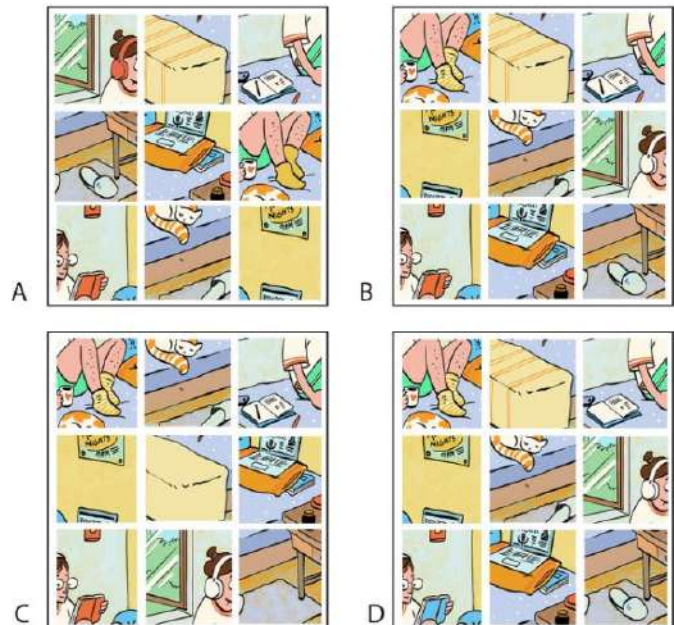

Q.57

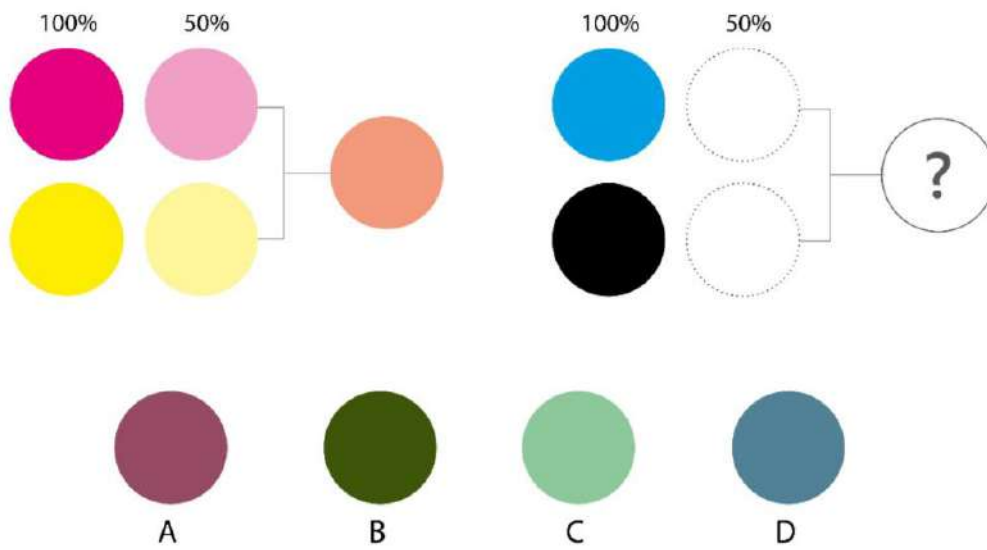

Q.58 Fill in the blank with the same font.

INDIAN_

S
A

S
B

S
C

S
D

Q.59 A folding paper fan P is dipped in orange colour and then in red colour as shown. Which option is the closest representation of the resultant fan?

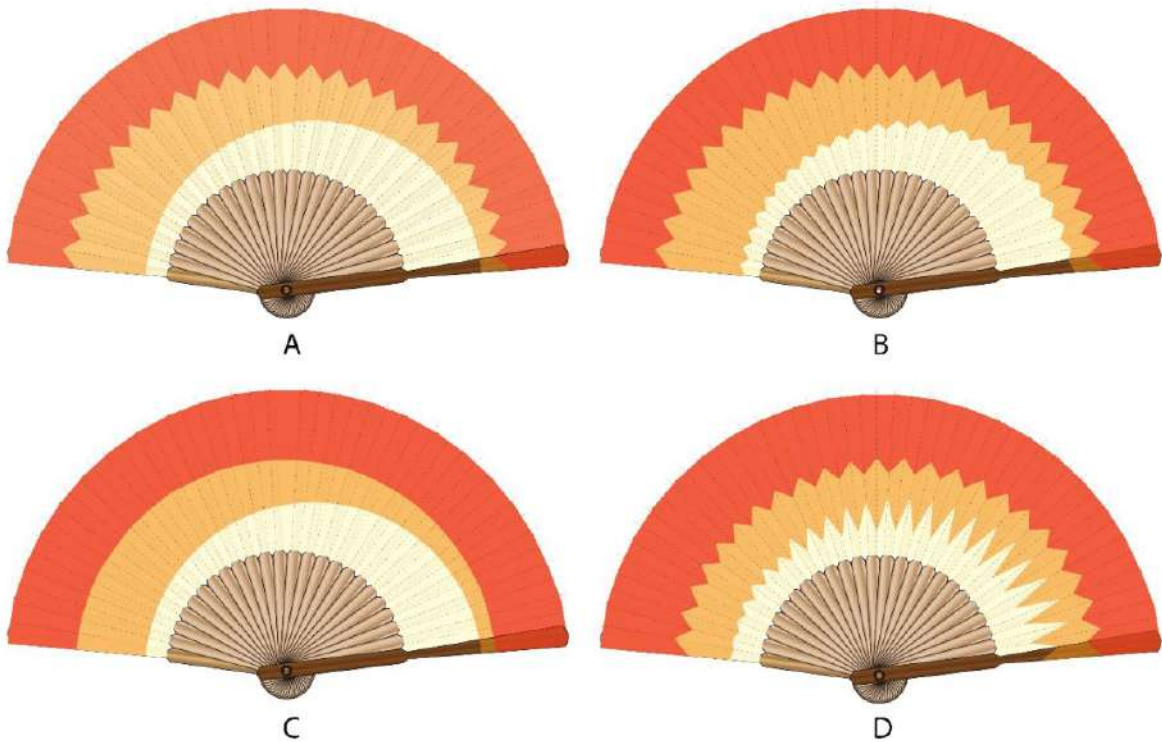
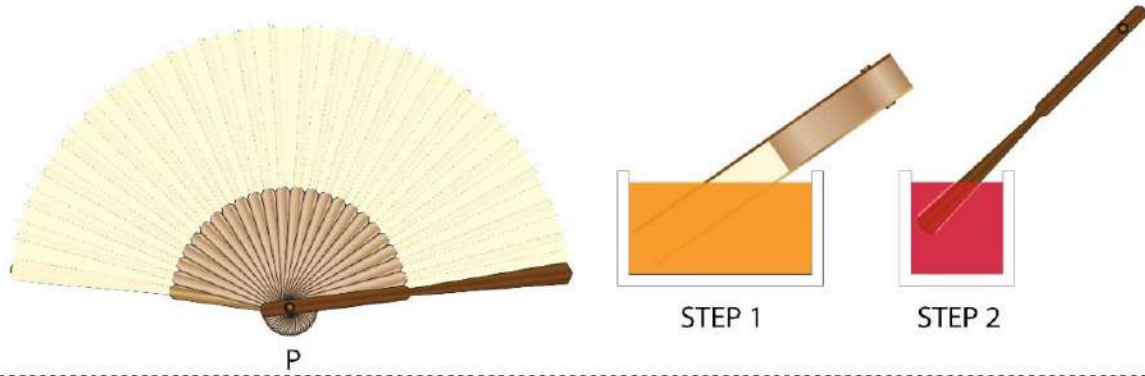

Q.60 A painting was created on the road as shown in the image. From the given options, identify which image was used to plan the painting (as seen from the top view).



A



B



C



D

Q.61 A game board was set with multiple decks of cards arranged in such a way that sum total of the cards on each side was equal ($1+2+3+4=10$). However, a new card was added on one side (blue card) and the cards were rearranged to maintain the rule, namely, that the sum total equals 10. How many cards can be added (starting from original position as shown on the left) before the game ends and no more cards can be added? Assume that every position must have at least one card and the sum total rule of 10 must be followed.

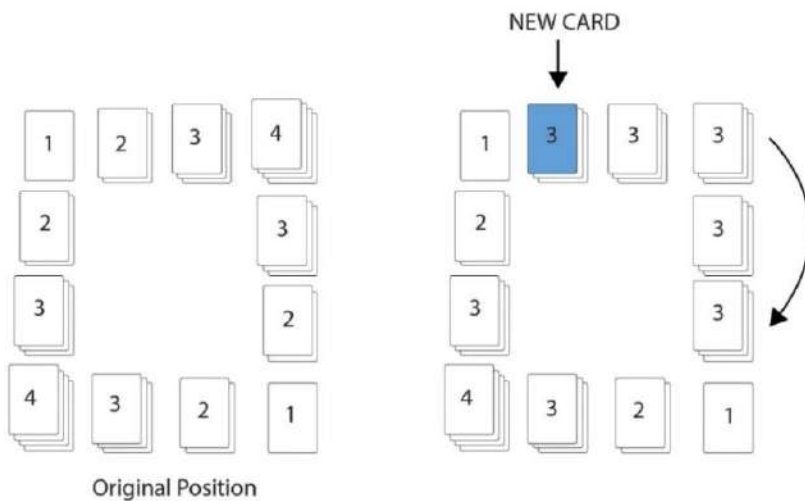

- A. 4
- B. 6
- C. 8
- D. 10

Q.62 Fatima is shown kicking the football. Identify the most appropriate illustration of the scene observed from behind.

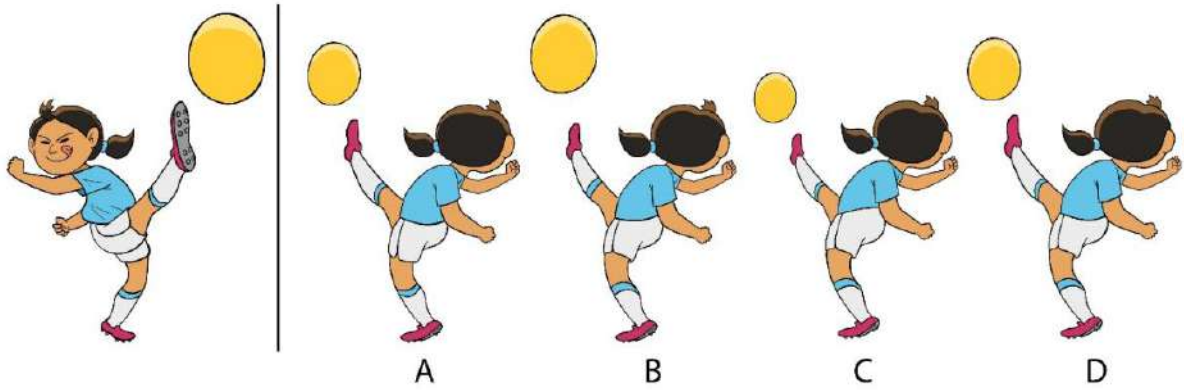

Q.63 Identify the correct silhouette of the coloured dragon.



Q.64 Shown below are trajectories of 4 flies over the juice glasses. Identify the fly that crossed over the maximum number of glasses.

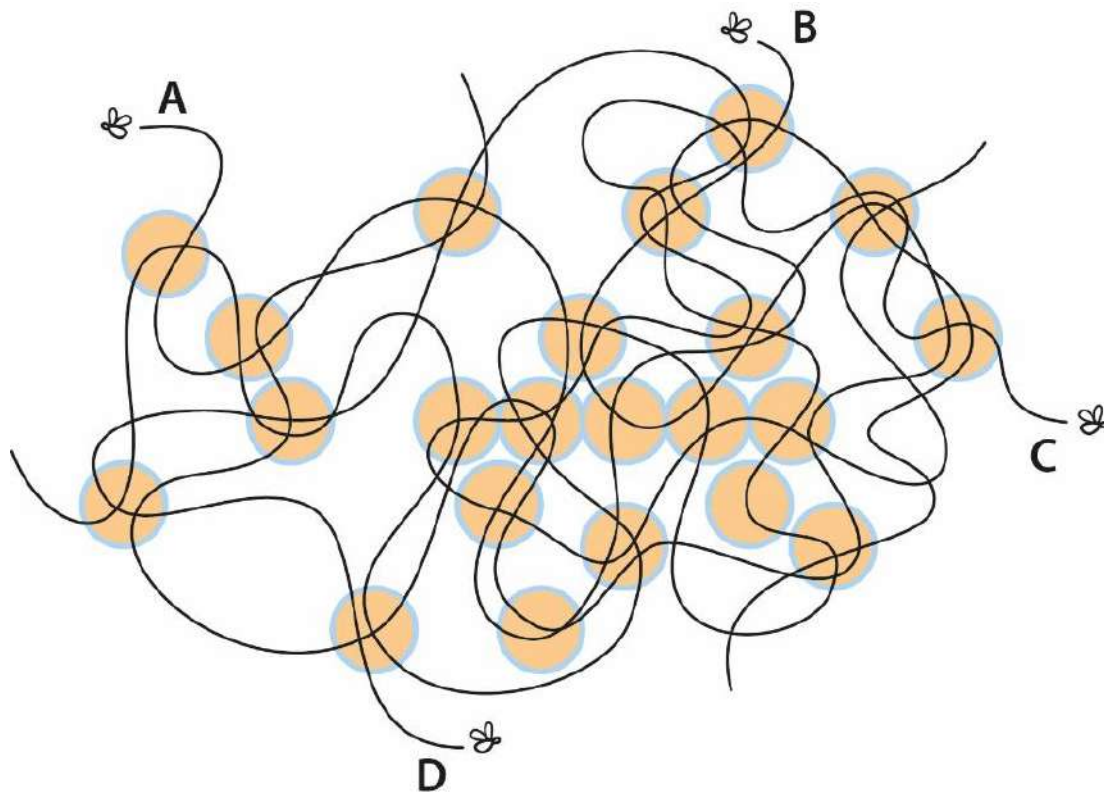

Q.65 A list of 8 country names in Vietnamese (shown in red), and their English translations (shown in blue) are given below. The translation list is mixed up. Which of the following statements is **TRUE**?

Áo, Ba Lan, Bỉ, Đan Mạch, Hà Lan
Na Uy, Phần Lan, Thụy Điển

Finland, Austria, Denmark, Norway,
Netherlands, Belgium, Sweden, Poland

- A. Đan Mạch is Denmark, Thụy Điển is Sweden, Phần Lan is Poland
- B. Hà Lan is Netherlands, Áo is Austria, and Ba Lan is Poland
- C. Bỉ is Belgium, Hà Lan is Finland, and Na Uy is Norway
- D. Na Uy is Netherlands, Thụy Điển is Denmark, and Phần Lan is Finland

Q.66 India and Australia are playing the finals of World Cup T20 cricket match. India won the toss and decided to bat. At the end of 5 overs, India scored 24 runs with one wicket down. From there on, in every 5 overs, India scored 50% more runs than the previous 5 overs and lost two wickets. From the options, identify the correct graph that shows India's final score.

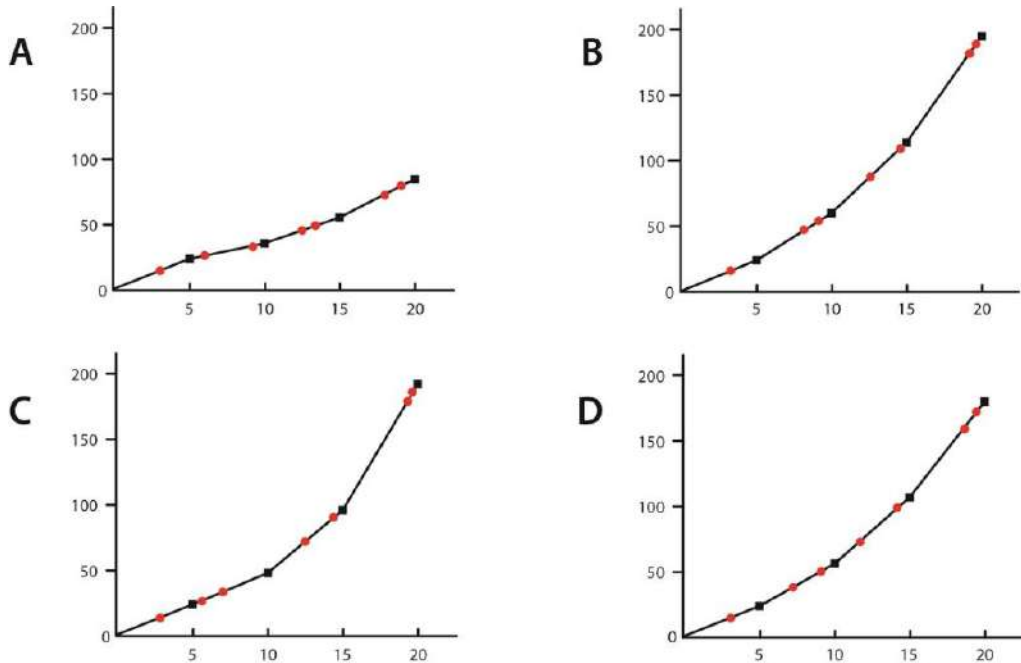

Q.67 Figure P shows a profile of a bus with circular wheels on a flat road. The options below show profiles of 4 wheels and corresponding roads. If the 'wheel' always moves without slipping or sliding, which of the options will result in the bumpiest ride?

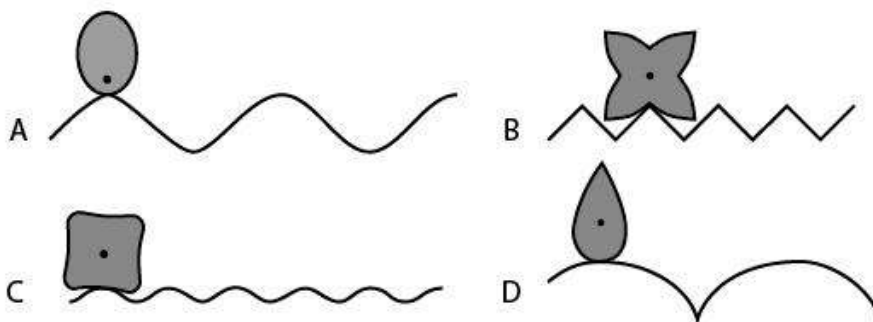
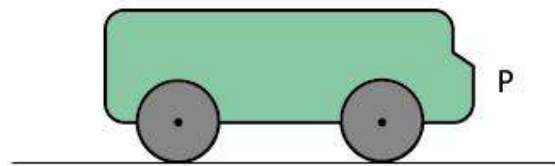

- Q.68** In the figure shown below, the drive wheel P engages with the driven wheel Q through a pin marked in red. Which of the options describes the movement of Q, when P moves in the clockwise direction?

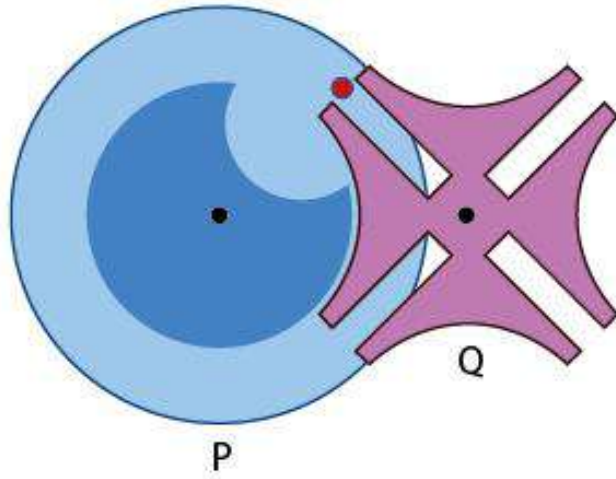

- A. Continuously anti-clockwise
- B. Intermittently anti-clockwise
- C. To and fro
- D. Intermittently clockwise

PART-B

Q. 69 Sketching (Mandatory question)

(30 minutes – 60 marks)

Read and visualize the following:

- A rat is spotted inside a school canteen.
- A school boy is afraid and standing on a stool/chair.
- A brave school girl is chasing the rat out of the canteen.
- A tiffin box is falling on the floor.
- Two school bags and two water bottles are kept on a table.
- A few plates are broken and lying on the floor.
- The canteen owner is watching this in shock, standing on top of the counter table.

Sketch this scene from the canteen owner's point of view.

Note:

- Make a pencil sketch only
- Do not use colours

Evaluation Criteria:

- Perspective
- Proportion
- Composition
- Observation
- Imagination
- Quality of sketch
- Attention to detail

UCEED 2021
FINAL ANSWER KEY

SECTION – A (NAT)

Q. No.	KEY RANGE	Q. No.	KEY RANGE	Q. No.	KEY RANGE	Q. No.	KEY RANGE	Q. No.	KEY RANGE
01	4900	02	21	03	16	04	35	05	6.28
06	233	07	9	08	6	09	7	10	21
11	48	12	13	13	2044	14	16.12 (15.00~16.50)	15	24 OR 49
16	600	17	40	18	2				

SECTION – B (MSQ)

Q.No.	KEYS	Q.No.	KEYS	Q.No.	KEYS	Q.No.	KEYS	Q.No.	KEYS
19	A,D	20	A,B,C,D	21	C,D	22	A,B	23	B,C,D
24	A,B,D	25	A,B	26	B,C	27	B,C	28	C
29	B,C,D	30	A,B,C,D	31	B,D	32	A,C	33	C,D
34	B,C	35	A,C	36	B,C,D				

SECTION – C (MCQ)

Q.No.	KEY	Q.No.	KEY	Q.No.	KEY	Q.No.	KEY	Q.No.	KEY
37	C	38	D	39	C	40	B	41	B
42	C	43	C	44	C	45	C	46	A
47	D	48	B	49	B	50	D	51	A
52	D	53	C	54	C	55	A	56	C
57	B	58	B	59	C	60	D	61	A
62	A	63	C	64	D	65	B	66	D
67	C	68	B						

Undergraduate Common Entrance Examination for Design

UCEED 2021

PAPER

Paper Specific Instructions

1. The total duration of the examination is 3 hours. The question paper contains two parts – Part A and Part B. The duration of Part A is **2 hours and 30 minutes**. Part B will begin after Part A ends. Part A is divided into three sections, 1, 2 and 3. All sections are compulsory. Questions in each section are of different types. There are a total of **68 questions** carrying a total of 240 marks. Questions of Part A will appear on the computer. Answers to **Part A** have to be entered in the **computer**. **Part B** is also compulsory and contains **1 drawing question** of 60 marks.
2. Marking scheme of Part A is as follows:

Section	Number of questions	Marks for each correct answer	Marks for each wrong answer	Marks for each question not attempted	Total marks for the section
NAT	18	4	0	0	72
MSQ	18	4	-0.19	0	72
MCQ	32	3	-0.71	0	96
Total	68				240

3. **Section 1 (72 Marks)** of Part A contains a total of 18 **Numerical Answer Type (NAT)** questions. For each question, the answer is a **real number with decimal digits up to two decimal places** that needs to be entered using the virtual keyboard on the monitor. No choices will be shown for these questions. There is **NO NEGATIVE MARKING** for this section. Questions from 1 to 18 belong to this section.
4. **Section 2 (72 Marks)** of Part A contains a total of 18 **Multiple Select Questions (MSQ)**. Each question may have **one or more than one correct choice(s)** out of the four given. A question is considered correctly answered if ALL the correct choices and NO wrong choices are selected for that question. There is **NEGATIVE MARKING** for this section. There is NO PARTIAL MARKING for this section. Questions from 19 to 36 belong to this section.
5. **Section 3 (96 Marks)** of Part A contains a total of 32 **Multiple Choice Questions (MCQ)**. Each question has four choices out of which ONLY ONE is correct. There is **NEGATIVE MARKING** for this section. Questions from 37 to 68 belong to this section.
6. **Part B (60 Marks)** contains one drawing question. There is **NO NEGATIVE MARKING** in this section. Answers to **Part B** have to be given in the **answer book** provided by the invigilator.
7. Calculators, charts, graph-sheets, mathematical tables, mobile phones, smart watches and/or other electronic gadgets are **NOT** allowed in the examination hall.
8. Blank sheets of paper will be provided for rough work.

PART A

Section 1: Numerical Answer Type (NAT)

questions

*Section 1 (72 Marks) of Part A contains a total of 18 Numerical Answer Type (NAT) questions. For each question, the answer is a real number that needs to be entered using the virtual keyboard on the monitor. No choices will be shown for these questions. There is **NO NEGATIVE** marking for this section. Each correct answer will be awarded 4 marks. Questions that are not attempted or answered incorrectly will be given zero mark. Questions from 1 to 18 belong to this section.*

- Q.01** Four identical pieces of wood of length 50 cm x 8 cm x 2 cm are arranged as shown in the figure. Another larger square is generated by rotating all the wooden panels along the outer edges and extending the outermost edges till they touch each other. What is the area of this larger square thus constructed?

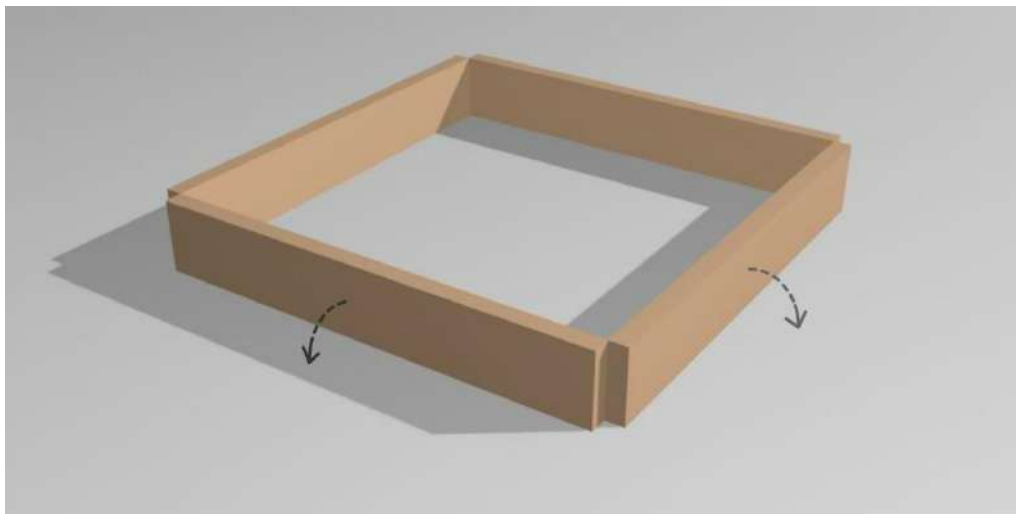

- Q.02** A cricket team has 10 blue pairs of gloves and 10 white pairs of gloves in a cricket kit. If a batter reaches into the kit and pulls out one glove at a time without looking at it, what is the least number of gloves she must pull out to make sure that she has a **pair** of gloves of the **same** colour?

Q.03 Chinnu was excited about the New Year when she bought a new calendar to keep on her study table. While playing, her baby sister poked a hole through the entire calendar from January through December as seen in the image. If every page had the same 5 week table structure for each month, and if all the consecutive months were printed back to back, which date in the month of April has a hole in it?

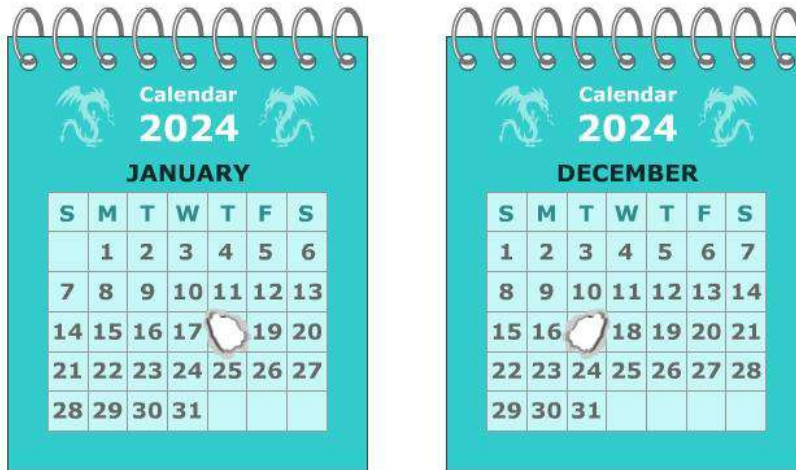

Q.04 How many triangles are there in the figure shown?

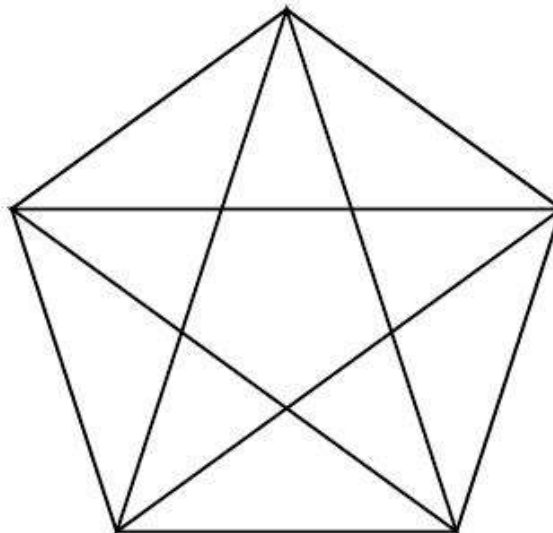

- Q.05** The corners of the green and red triangles coincide with the centres of the circles. All the circles have equal diameters and adjacent circles touch each other. If the area of the green triangle is 3.14, what is the area of the red triangle?

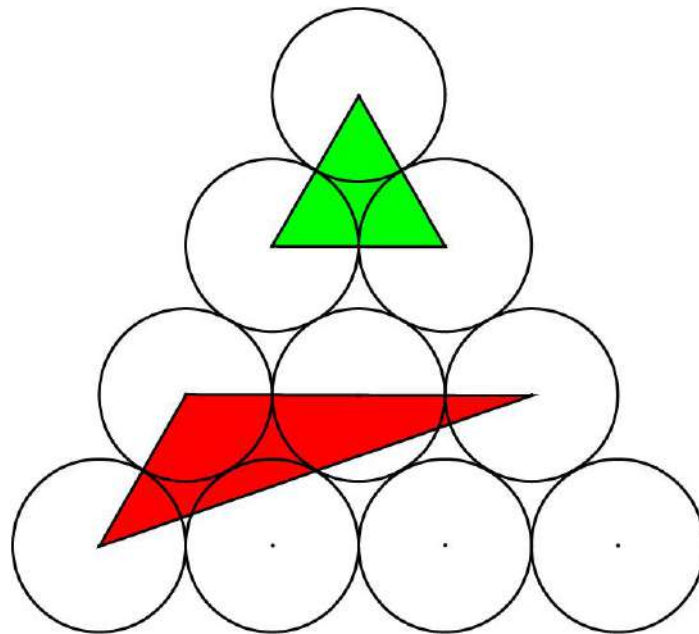

- Q.06** A Street has 13 houses in a row as shown in the figure. Some residents in the first house tested positive for COVID-19. The virus spreads in two ways: it can spread to the next house, or jump directly to the third house. Residents of house number 2 can get infection in only one way, the house number 3 in two ways, the house number 4 in 3 ways, the house number 5 in 5 ways and so on. If the virus **only** progresses from **Left to Right** direction, in how many ways can the residents of the house number 13 get infected?

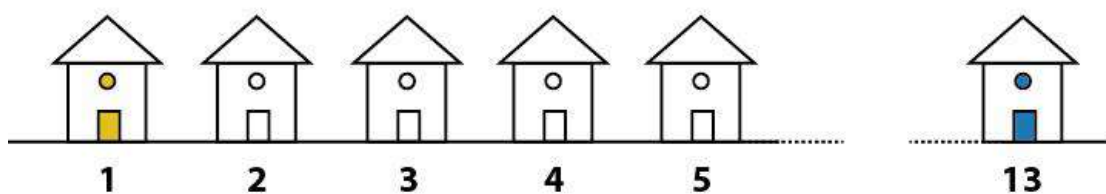

Q.07 In the container given below of dimensions (40 cm X 20 cm X 20 cm), four objects are dipped in water. Objects **P** and **Q** are made of some light material while objects **R** and **S** are made of iron and copper, respectively. The object **P** is a cube of edge 4 cm with $1/10^{\text{th}}$ floating above water; object **Q** displaces 50 cc of water while floating. The volumes of objects **R** and **S** are 295.4 cc and 397 cc, respectively. If all the objects are removed from the container, what would be the new water level inside the container measured from the bottom?

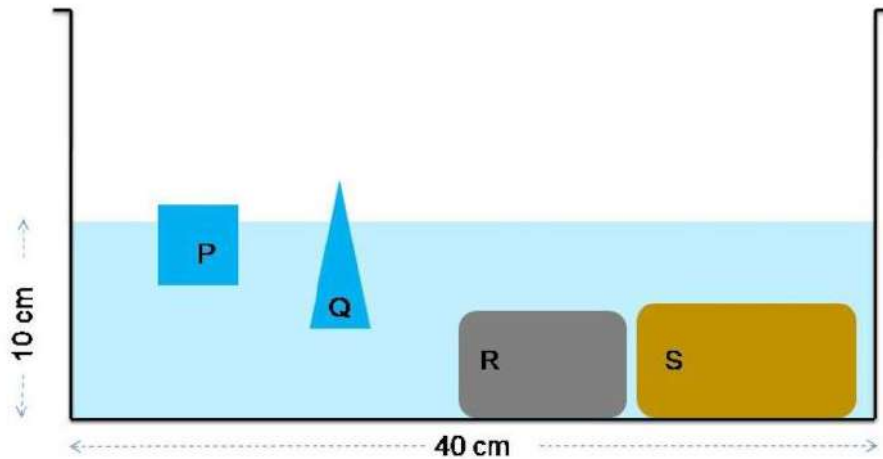

Q.08 If you start from the **circle** and end at the **triangle**, what is the minimum number of straight lines required to pass through all the dots without retracing any route? You are allowed to pass through a dot more than once.

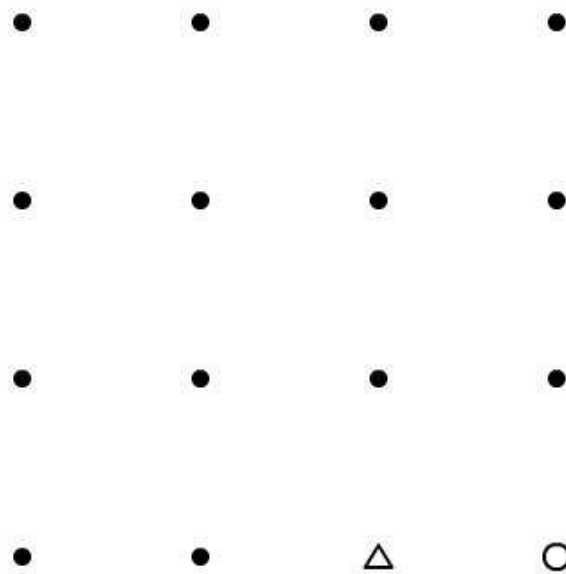

Q.09 If each word is written in a single font and normal and bold versions of the same font are not to be counted separately, how many fonts are used in the given set of words?

पाठव पाठव पाठव पाठव
पाठव पाठव पाठव पाठव
पाठव पाठव पाठव पाठव

Q.10 The figure shows views of the same solid. Count the number of surfaces.

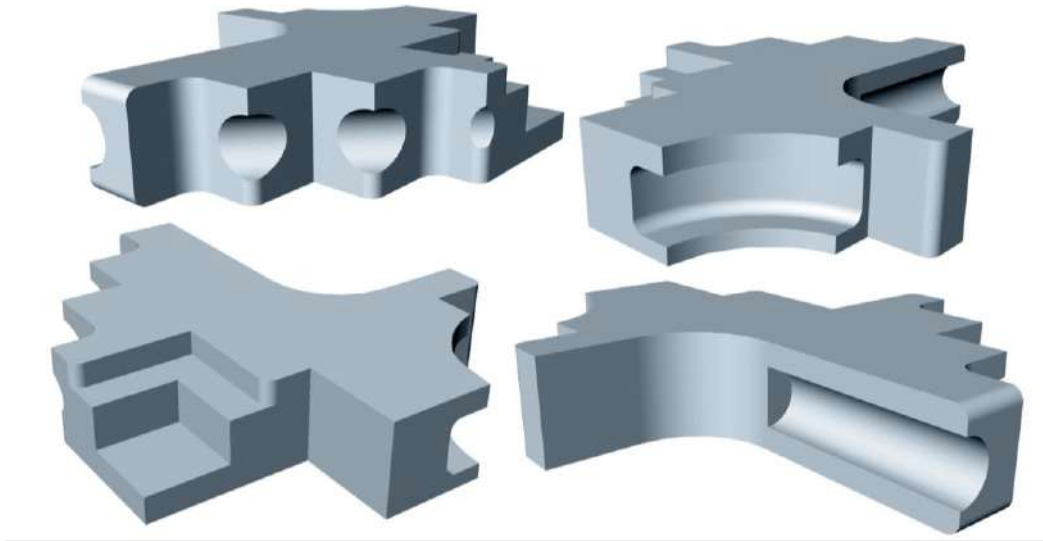

Q.11 There are apples and oranges in a basket that can carry a maximum of 50 fruits. Some fruits are rotten and some are good. The number of rotten apples is twice the number of good apples. The number of good oranges is twice the number of rotten oranges. The number of oranges is thrice the number of apples. If there are more than 40 fruits in the basket, what is the total number of apples and oranges?

Q.12 Four views of a convex solid are shown. How many surfaces does the solid have?

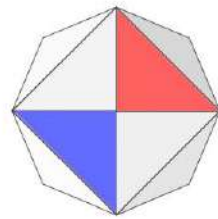

Top view

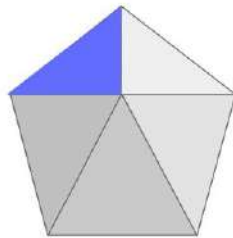

Front view

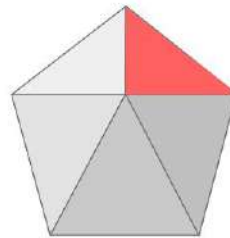

Side view

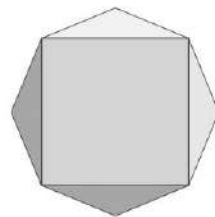

Bottom view

Q.13 When young Moosa started selling dosas on a street corner to support his daughter Lisa's education, his age was six times that of Lisa's. He started selling dosas for ₹2 each and he increased its price by ₹1 every year. Lisa grew up to be a successful lawyer and on Moosa's 60th birthday she gifted him with a small shop near their house, the board of which is seen in the image. In which year Lisa will celebrate her 60th birthday?

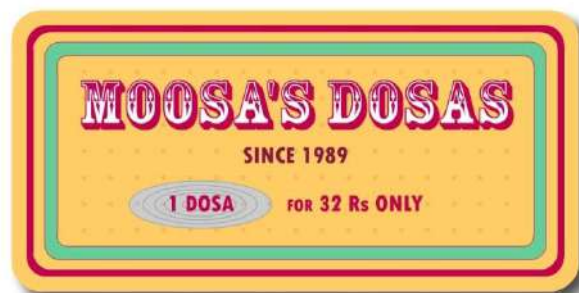

- Q.14** Three circles of radius 10 cm are drawn inside an equilateral triangle as shown below. The area of the red coloured region (in sq. cm., up to two decimal places) in the figure is ____.

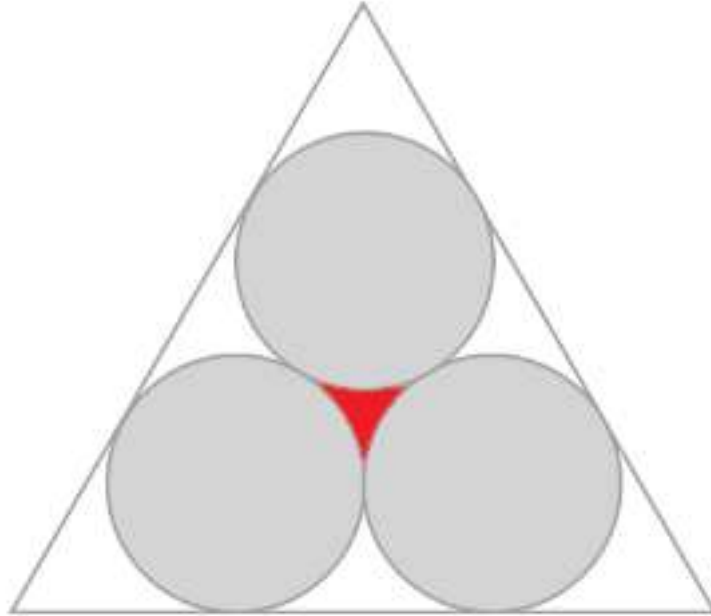

- Q.15** A smaller square of 5 cm is placed inside a bigger square such that all 4 corners of the smaller square are touching the sides of the bigger square. If the smallest distance between the corners of the two squares is 3 cm, what is the area of the bigger square in sq. cm that falls outside smaller one?
- Q.16** A digital clock reads hours and minutes. The sum of the digits it displays at 12:00 is 3 (1+2+0+0). At 12:01 it is 4 (1+2+0+1) and so on. What is the sum of all the digits it displays from 12:00 to 12:59?

Q.17 A rhombus is inscribed in a rectangle which in turn is inscribed in a circle as shown in the figure below. **P** is the centre of all three shapes, **PQ=QR=5** units. What is the perimeter of the rhombus?

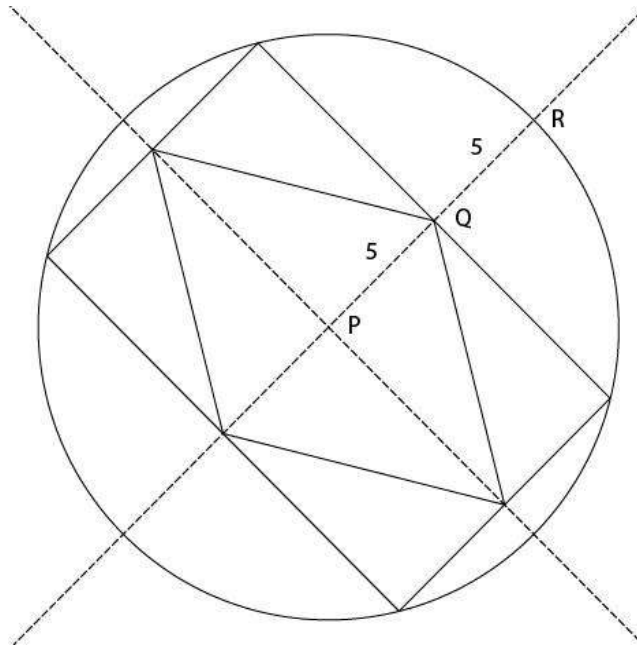

Q.18 If colour and size differences are not to be counted as unique, how many types of leaves occur only once?



Section 2: Multiple Select Questions (MSQ)

Section 2 (72 Marks) of Part A contains a total of 18 **Multiple Select Questions (MSQ)**. Each question may have **one or more than one correct choice(s)** out of the four given. A question is considered correctly answered if **ALL** the correct choice(s) and **NO** wrong choice(s) are selected for that question. There is **NEGATIVE MARKING** for this section. Each question answered correctly will receive 4 marks. Each question wrongly answered will receive -0.19 (minus zero point one nine) mark. There is **NO PARTIAL MARKING** for this section. Questions not attempted will be given zero mark. Questions from 19 to 36 belong to this section.

Q.19 Which of the options is/are rotation(s) of the given figure?

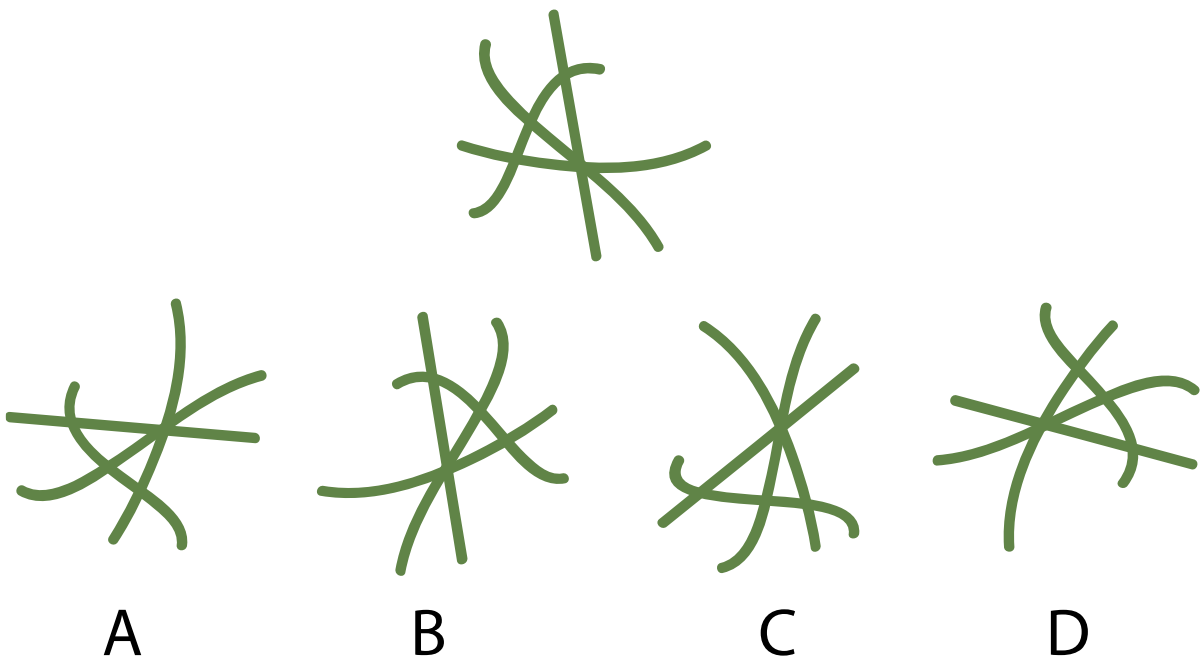

Q.20 Consider the following quote from J C Kumarappa's ***Economy of Permanence***:

"Man comes nearest to his God, the creator, when he utilizes his brain power to marshal mechanical forces to serve his purposes. To do so in a way that will bring blessings and not destruction, he has to follow closely nature's way to get the best out of it. We cannot get the co-operation of nature purely on our own terms. Any attempt to do so will bring violent destruction in its wake."

Which of the options is/are implied by the quote?

- A. Utilizing brain power to marshal mechanical forces to serve our purposes, if not done properly, can lead to destruction.
- B. Utilizing brain power to marshal mechanical forces to serve our purposes can bring man nearest to his God.
- C. While utilizing brain power to marshal mechanical forces to serve our purposes, the best way to proceed is to follow nature's way.
- D. Dealing with nature purely on our own terms will bring violent destruction.

Q.21 Which four pieces of a jigsaw puzzle can be combined to form a square?

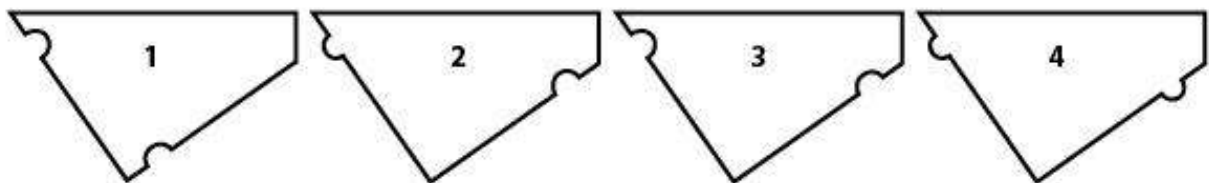

- A. 1, 2, 3, 4
- B. 3, 2, 4, 4
- C. 2, 2, 2, 2
- D. 2, 2, 3, 4

Q.22 After retiring, eight friends: Balram, Bhandari, Das, Munshi, Nadkarni, Parmar, Patel and Sethuraman purchased a square plot of land. They divided the land in 8 equal plots and a common back garden as shown. Parmar was allotted plot number 1. Balram preferred a house on the west. Patel chose to stay the farthest from Nadkarni's house. Munshi and Bhandari became neighbours of Nadkarni. Sethuraman became a neighbour of Patel. Nadkarni hails from the North East, so he chose the plot on the North East.

Which of the options **MUST BE** true?

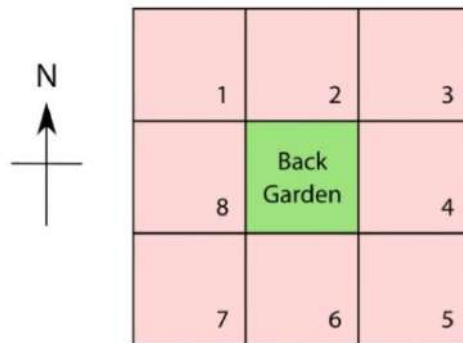

- A. Das stays in plot number 5.
- B. Munshi could be a neighbour of Parmar.
- C. Balram and Nadkarni could be neighbours.
- D. Balram shares a wall with Bhandari.

Q.23 Letters of the alphabet of a font are shown below. The cyan letters H, A and B illustrate how some of them can be folded once to form new shapes. They may be further transformed by rotation. Which of the black shapes given in the options have been folded once and rotated?

A B C D E F G H I J K L M
N O P Q R S T U V W X Y Z



- Q.24** Three friends **P**, **Q** and **R** go for morning walks around a ground. They start out together from the gate in the same direction, but walk at different speeds. **R** walks half as fast as **P**. **Q** walks 1.5 times faster than **R**. **P** takes 1 minute to take one round around the ground. If they all stop when **R** has finished 4 rounds, which of the options must be **true**?

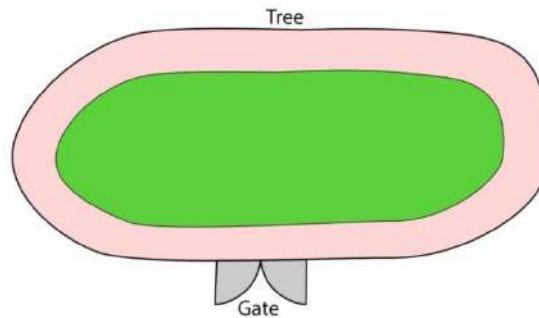

- A. Between the start and the end (not counting the start and the end instances), **P** and **R** meet each other thrice.
- B. Between start and the end (not counting the start and the end instances), **P** meets **Q** only once.
- C. **Q** will overtake **R** once near the Tree.
- D. At the end, **P**, **Q** and **R** will reach the gate at the same time.
- Q.25** Image shows part of a poster made by CDC in the context of COVID-19. Which of the statements is/are true?



- A. It effectively communicates physical distancing.
- B. It is gender neutral. It promotes mask usage.
- C. It is faith neutral and age inclusive.
- D. It effectively communicates all Covid-19 related safety measures.

Q.26 A toy was created using a piece of paper, the two sides of which are shown in the image. When dropped from a height it spins like a fan. Which of the options depict(s) the correct pattern formed while it spins?

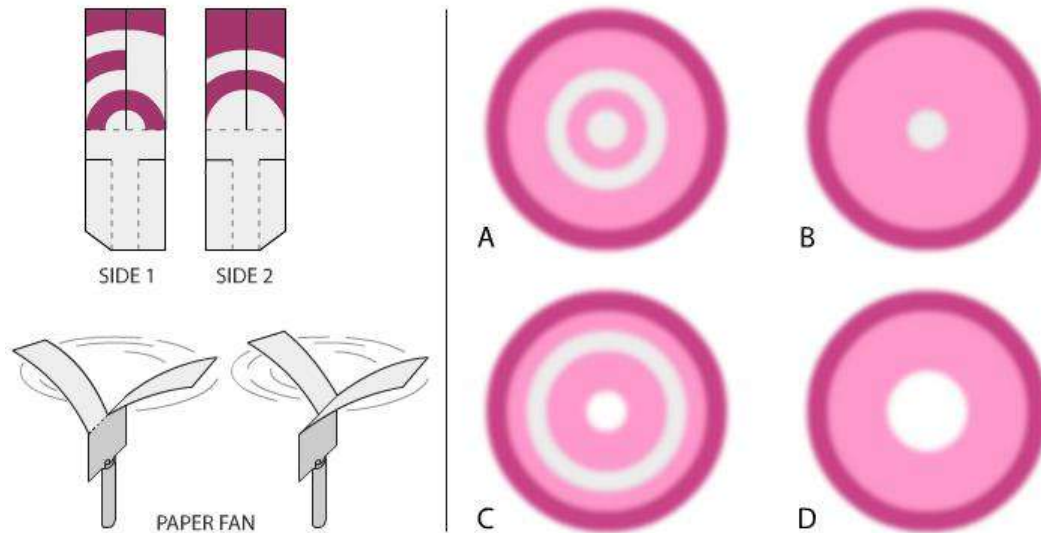

Q.27 Which option(s) can be folded to form the cube shown?

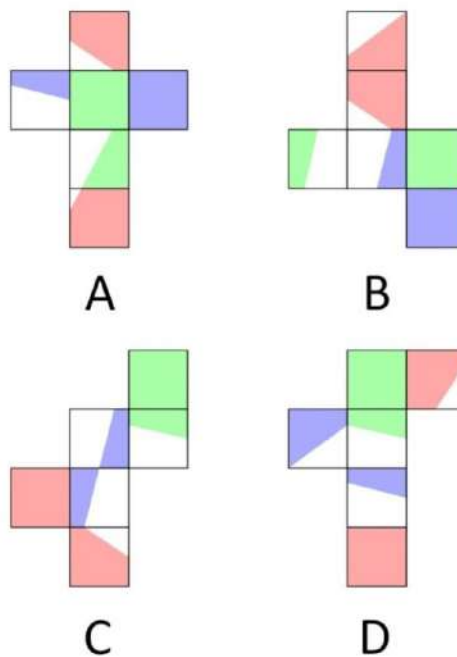
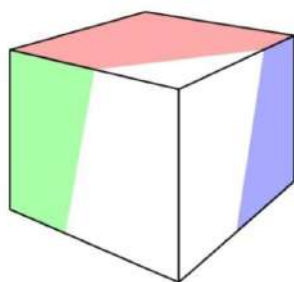

Q.28 Pressure cookers are sometimes made using copper and stainless steel. In such a pressure cooker,

- A. The bottom is made up of stainless steel and the rest is made up of copper because it is aesthetically pleasing.
- B. The bottom is made up of stainless steel and the rest is made up of copper because copper is a germicide.
- C. The bottom is made up of copper because it is a better conductor of heat compared to steel and hence it is more energy efficient.
- D. The bottom is made up of copper because that is the only way such a cooker can be heated using an induction stove.

Q.29 Rep-tile is a shape that can be dissected into smaller copies of the same shape without leaving any remainder. For example a square can be cut into various numbers of smaller copies of square shape.

If no flip is allowed, which of the options is/are rep-tiles?

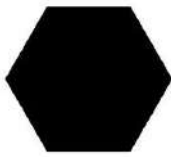

A



B



C



D

Q.30 Which of the object(s) given in the options can produce the top and front view as shown in the figure? Arrow shows the direction of front view.

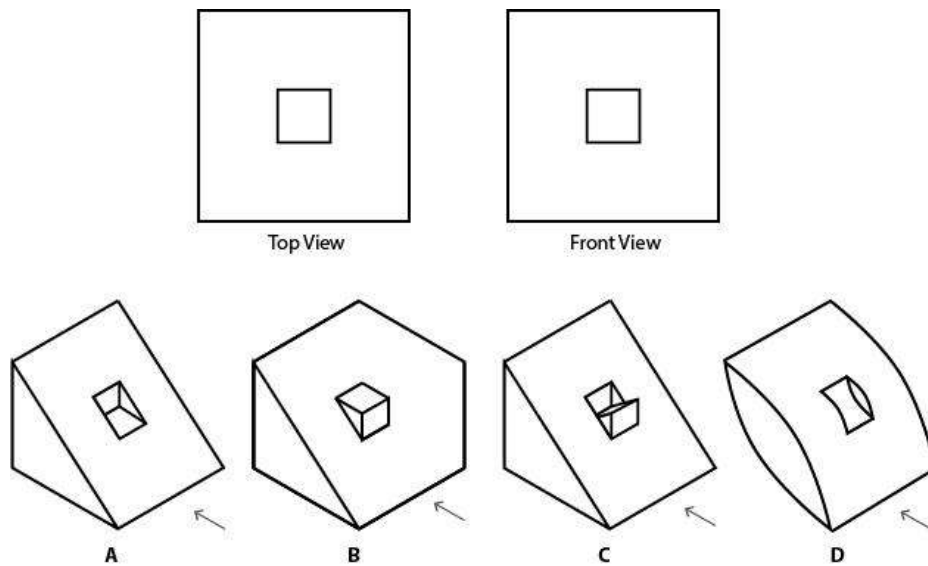

Q.31 [This question contains an animated GIF image. Please refer to that image]

A designer has created an infinitely looping animation as shown in the image. It has 24 frames playing at a speed of 12 frames per second. Which of the statements is/are true?

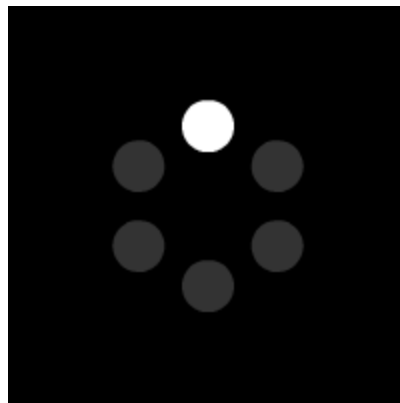

- A. The duration of one circular loop is 3 seconds.
- B. Each dot turns white for 4 frames in each loop.
- C. If this animation is played at 8 frames per second, the speed of animation will be faster.
- D. This animation with same duration is possible with 6 frames played at 3 frames per second.

Q.32 Three squiggles were drawn on three transparent square sheets in semi-transparent ink and piled together. Some sheets may be rotated. Additionally, in some options, some squiggles are different than the ones shown. In which option(s), do the squiggles look different?

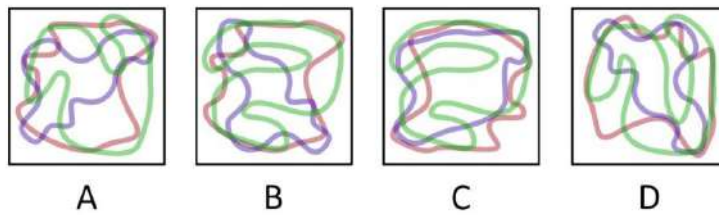
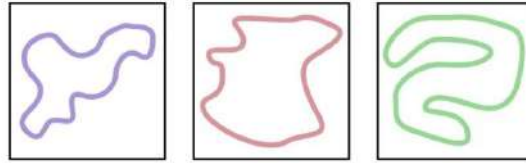

Q.33 A beat policewoman is starting her midnight walk. Starting from the signal **P1**, she heads west and takes the second right. Thereafter, she continues her journey, taking the second left, second left, third right, third right, and after that she goes and ends her beat walk at the next signal. In the given map, some of the intersections have traffic light signals and are marked with dots. Which of the options is/are true?

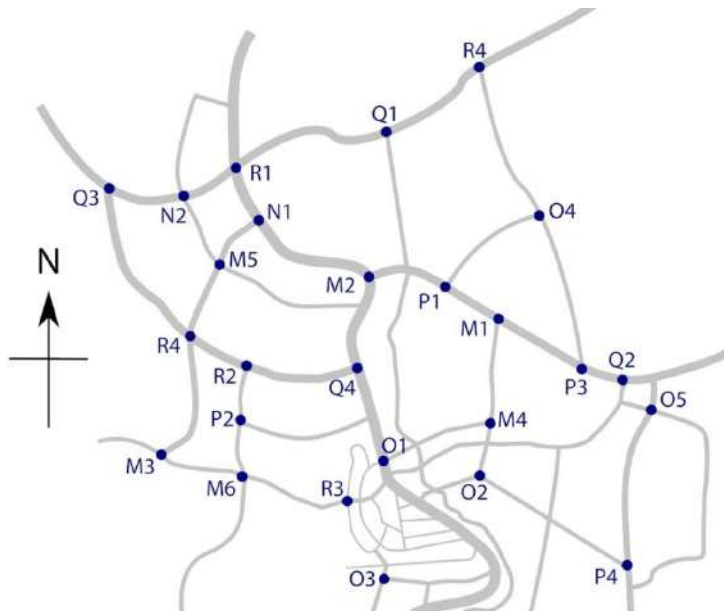

- A. The policewoman visits the signal **M6** twice
- B. She passes signals **M6**, **P2** and **R2** in that sequence
- C. She visits **R4** before **R2**
- D. She ends her beat walk at **R3**

Q.34 Which of the following relationships can be represented using the Venn diagram shown below?

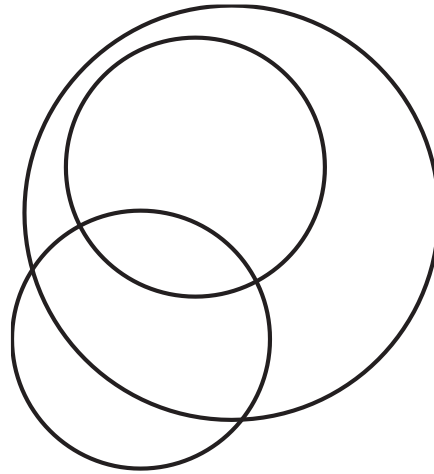

- A. Snack, Food, Dosa
- B. Female, Doctor, Mother
- C. Parrot, Pet, Bird
- D. Designer, Teacher, Painter

Q.35 From one side of a solid cube of side 2 units, a square pyramid of height 1 unit was removed as shown in the image, resulting in a solid with 9 surfaces. If one more pyramid of the same dimensions is removed from another side of the resultant solid, how many surfaces can the new resultant solid have?

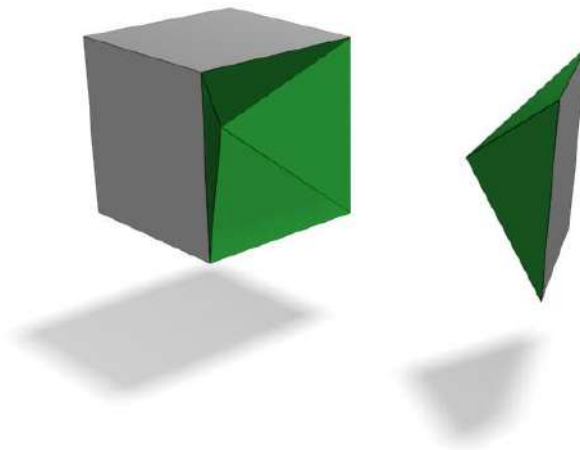

- A. 10
- B. 11
- C. 12
- D. 13

Q.36 If a solid octahedron as shown in the figure is cut by a plane into two pieces, what is/are the possible shape(s) of the cross-section?



- A. Triangle
- B. Square
- C. Pentagon
- D. Hexagon

Section 3: Multiple Choice Questions (MCQ)

Section 3 (96 Marks) of Part A contains a total of 32 **Multiple Choice Questions (MCQ)**. Each question has four choices out of which **ONLY ONE** is the correct answer. There is **NEGATIVE MARKING** for this section. Each correct answer will be awarded 3 marks and each wrong answer will receive -0.71 (minus zero point seven one) mark. Questions not attempted will be given zero mark. Questions from 37 to 68 belong to this section.

- Q.37** Consider the configuration in the given figure. If rotating and flipping are **not** allowed and pieces given in an option need not be placed in the given sequence, which combination would complete maximum number of horizontal black rows?

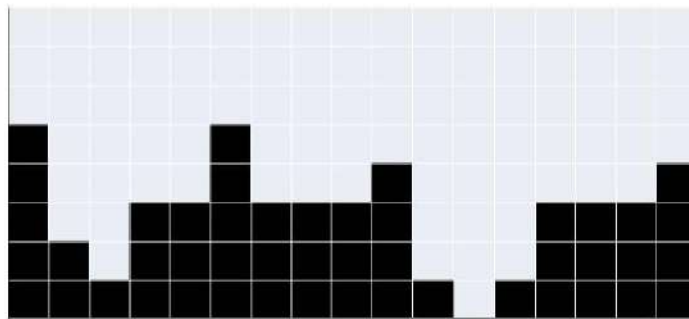

- A
-
- B
-
- C
-
- D
-

Q.38 Which of the options is the correct logo?

Amul
A

Amul
B

Amul
C

Amul
D

Q.39



P



Q



R



S

- A. **P** – Mauryan Empire, **Q** – Pallava Empire, **R** – Vijayanagar Empire, **S** – Mughal Empire
B. **P** – Mughal Empire, **Q** – Vijayanagar Empire, **R** – Chola Empire, **S** – Mauryan Empire
C. **P** – Mauryan Empire, **Q** – Chola Empire, **R** – Vijayanagar Empire, **S** – Mughal Empire
D. **P** – Mauryan Empire, **Q** – Chola Empire, **R** – Bahmini Sultanate, **S** – Mughal Empire

Q.40 Figure on the left represents a screen from a shadow puppetry show with the ARRANGEMENT 1 behind the screen. Which of the options will be the closest representation of the screen as a result of ARRANGEMENT 2?

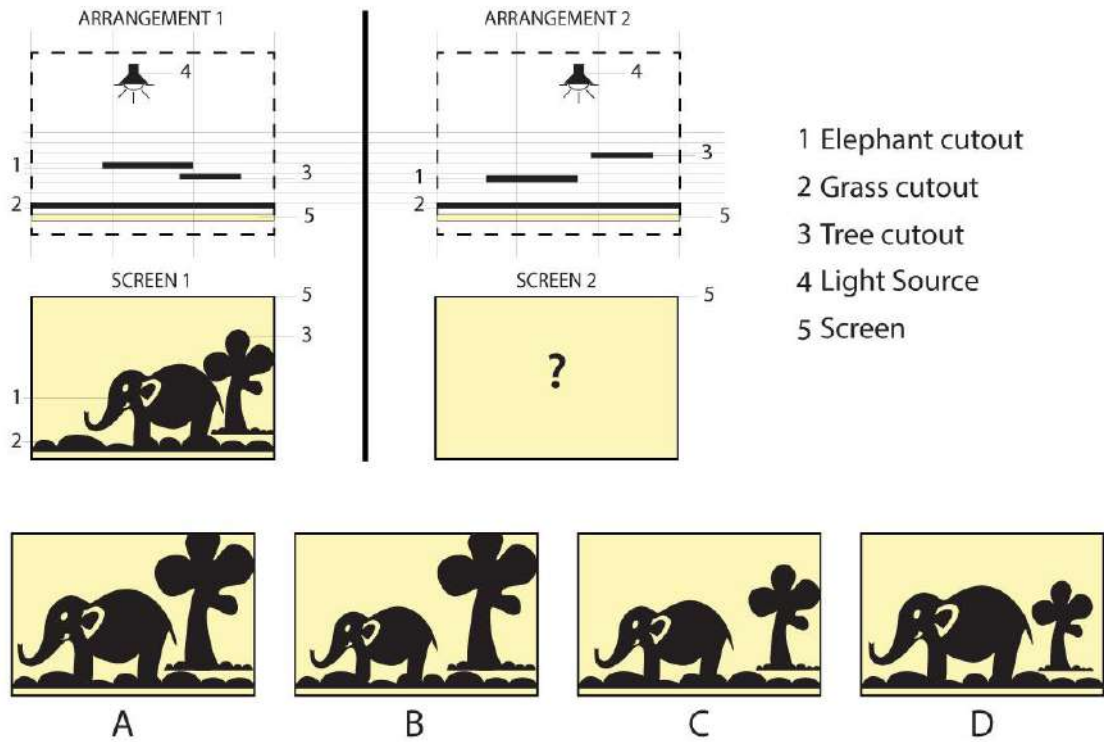

Q.41 The handle was erased from the drawing of a mug. Which of the options represents the part that was erased?

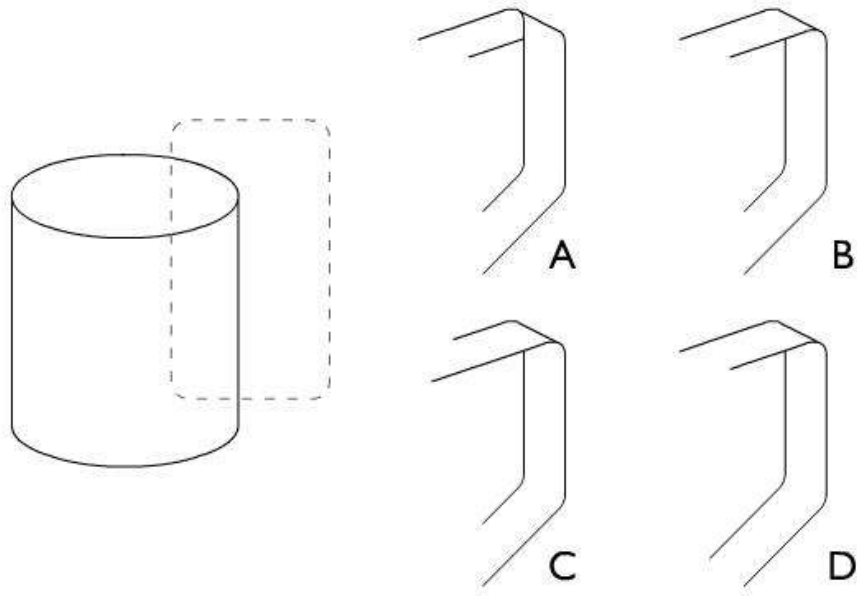

Q.42 Which of the options will replace the question mark in the given sequence?

F K ? U Z

- A. **C**
- B. **O**
- C. **P**
- D. **R**

Q.43 Two of the three lines shown below indicate the tracks made by a bicycle. Identify which is the front tyre track and which is the rear tyre track.

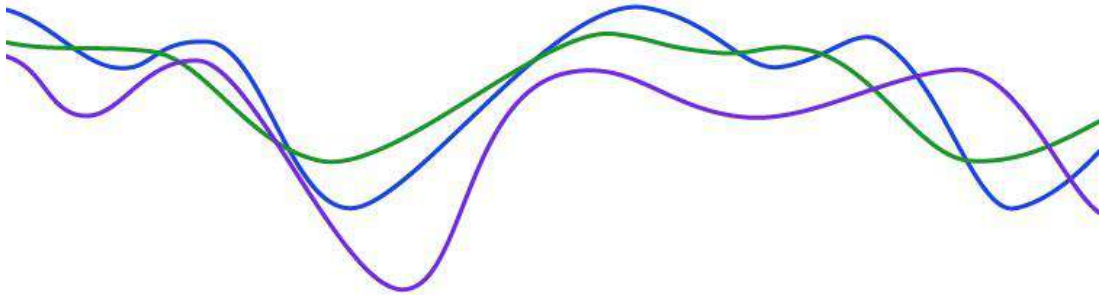

- A. Green is front, Purple is rear
- B. Green is front, Blue is rear
- C. Blue is front, Green is rear
- D. Blue is front, Purple is rear

Q.44 An artwork on a paper creates an illusion of a ladder resting on a wall when the paper is folded and viewed from a specific angle as shown in the image. Which of the options correctly depicts this artwork on the paper when unfolded?

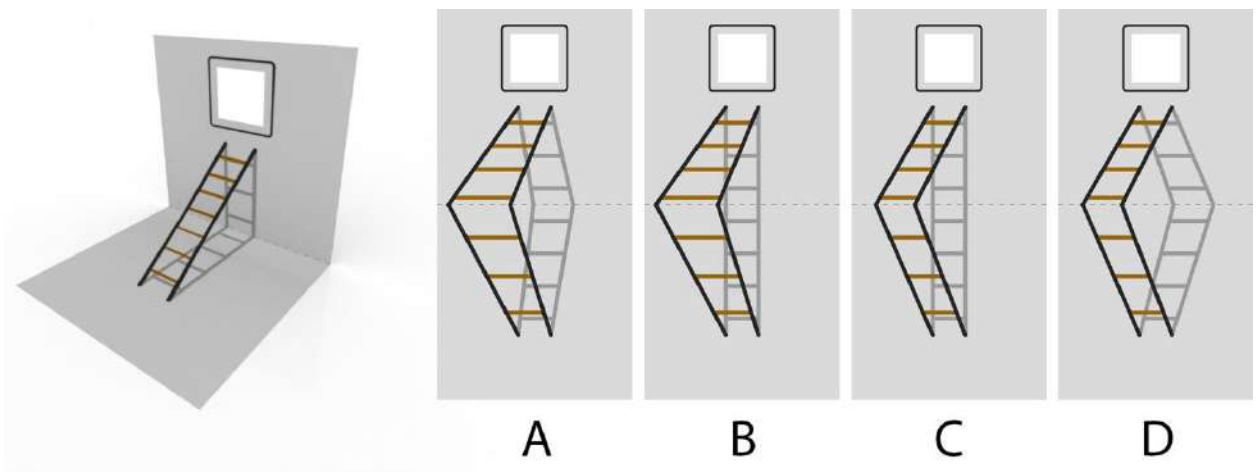

Q.45 On a race track shown below choose the correct starting configuration. The athletes are not allowed to change the tracks. Each grid is 2 m x 2 m.

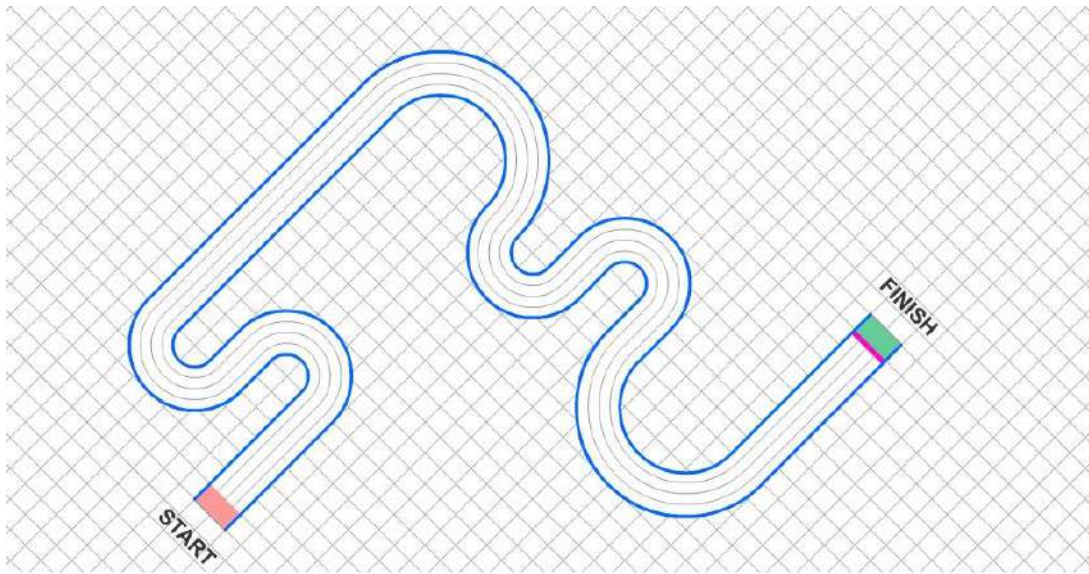

Q.46 Two identical cubes **P** and **Q** are made of smaller cubes in $3 \times 3 \times 3$ and $5 \times 5 \times 5$ configurations, respectively as shown below. Alternate cubes are painted green and white as indicated. Identify the correct option.

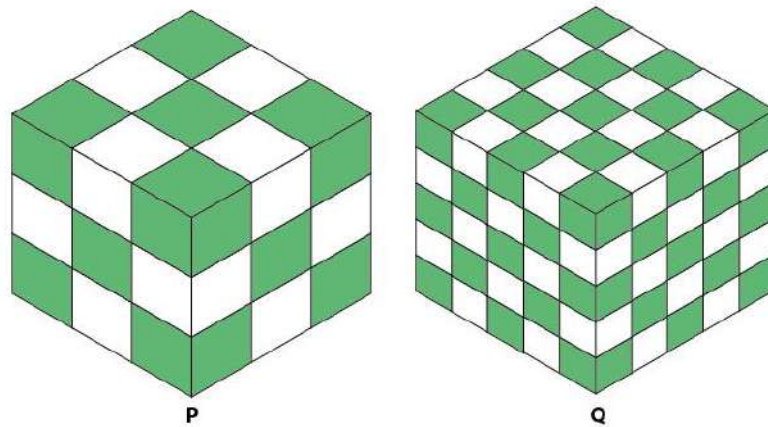

- A. The surface area of green is more in **P** than in **Q**
- B. The surface area of white is more in **P** than in **Q**
- C. The surface areas of green and white are the same in **P** and **Q**
- D. The surface area of green is the same but the area of white is different in **P** and **Q**

Q.47 The image shows the top views of an L shaped sculpture resting on a planar ground. When light falls on it at an angle of 45 degrees from the ground in the directions marked as an arrow in the image, the corresponding shadows are formed on the ground. Which of the options is this sculpture?

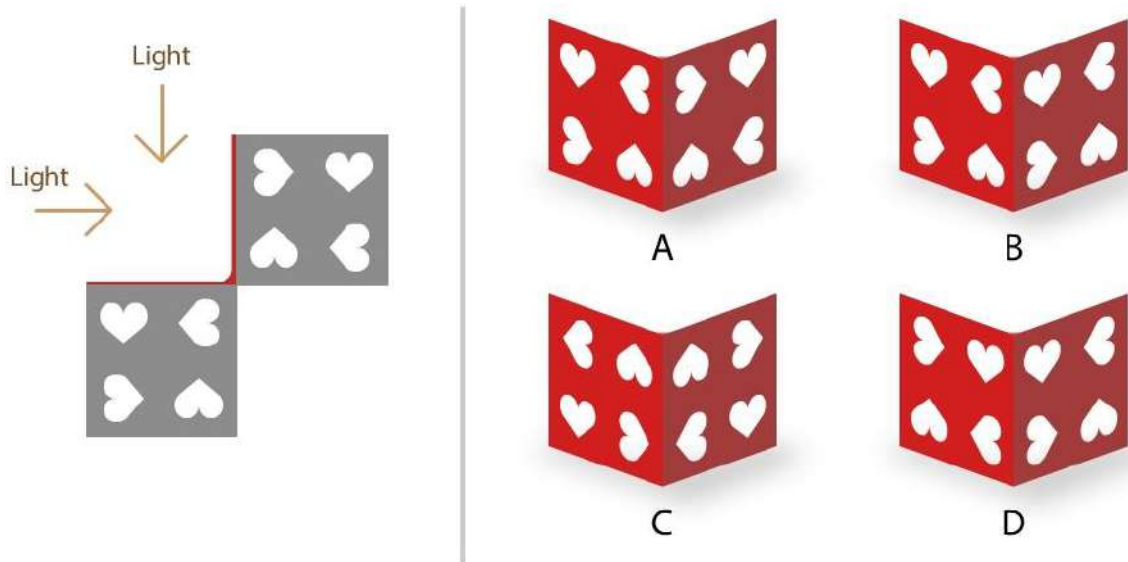

Q.48

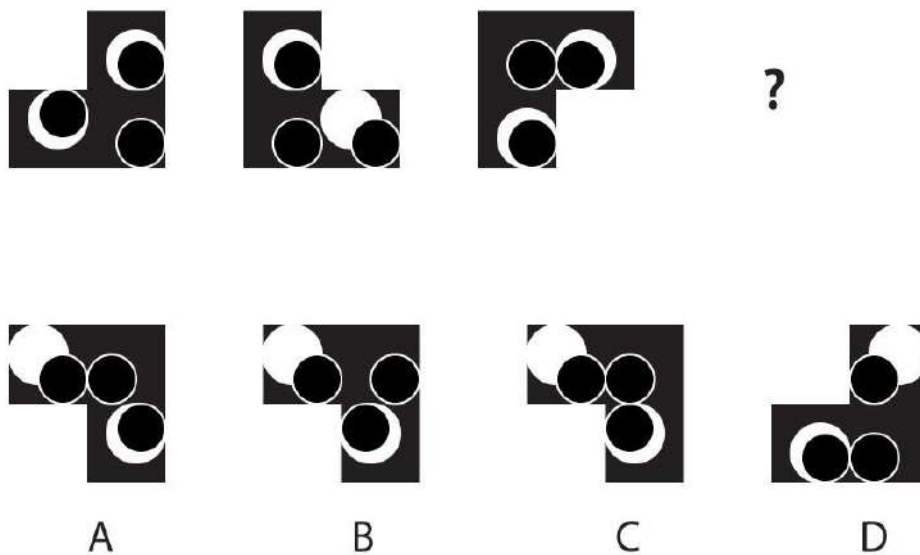

Q.49 An animator was trying out options of various rough poses while planning a frame of a shot. Mirroring and silhouetting are two aspects that animators need to consider when deciding whether a pose is good or not. (The left and right side having the same pose, i.e. mirrors of one another is called Mirroring. Silhouetting refers to the shape of the pose if it was a silhouette, i.e. the outline of the pose.) Based ONLY on these two aspects, which of the options can be considered the **WEAKEST** pose?

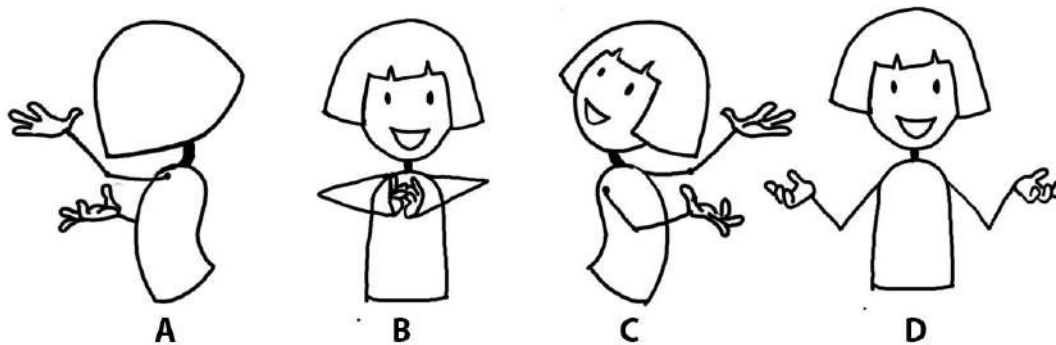

Q.50 At 6:00 pm, the hour hand and the minute hand of an analog clock are at 180 degrees with each other. After approximately how much time will they be at 180 degrees with each other again?

- A. 48 minutes, 40 seconds
- B. 54 minutes, 33 seconds
- C. 60 minutes
- D. 65 minutes, 27 seconds

Q.51 Which of the kettles shown below can hold the most amount of water when placed on an even, horizontal surface?

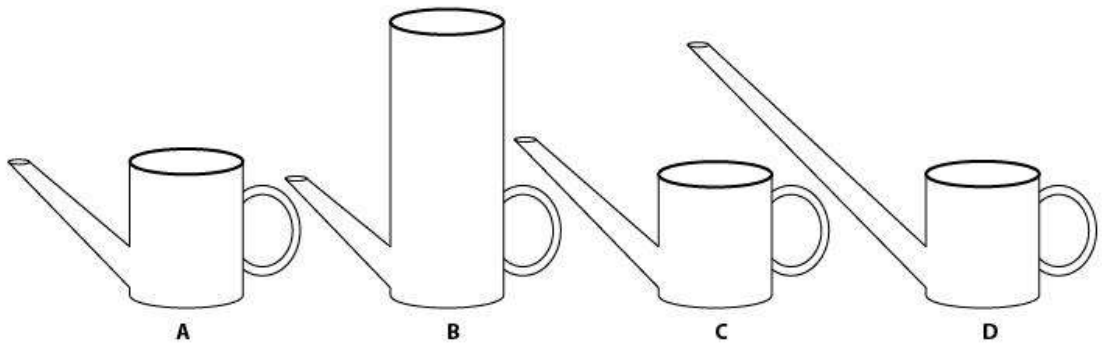

Q.52

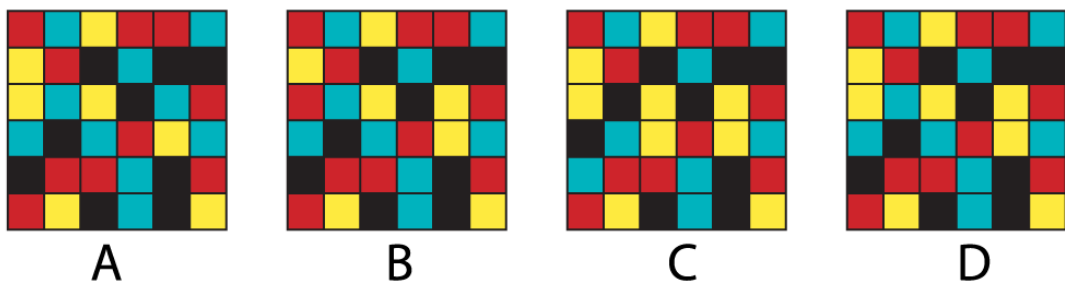
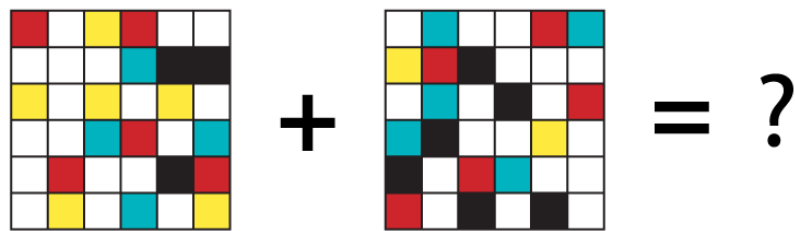

Q.53 A plane is landing smoothly on the airport runway. Select the correct picture.

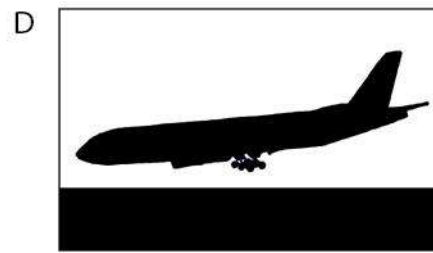
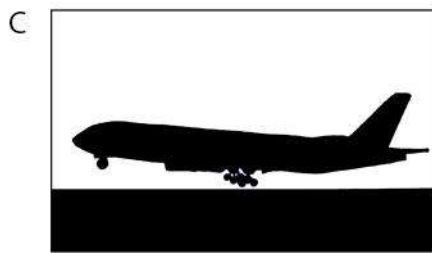
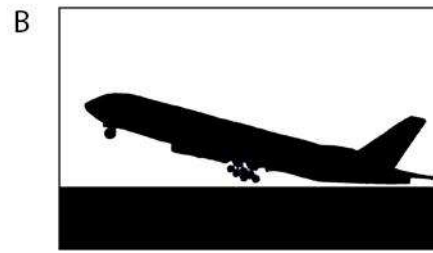
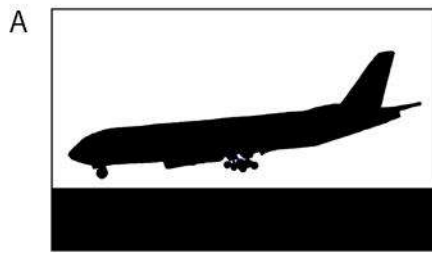

Q.54 In the series given, the first is an equilateral triangle, the second becomes a square by rearranging the pieces, and the third becomes a regular pentagon **without any rotation**. Similarly, the fourth becomes a regular hexagon. Which of the options given therefore replaces the question mark?

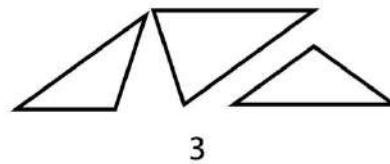
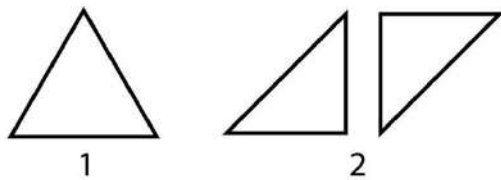

4 ?

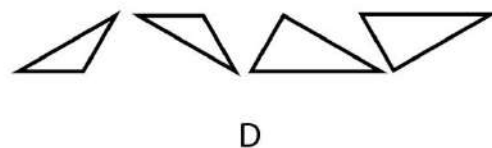
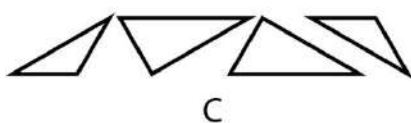
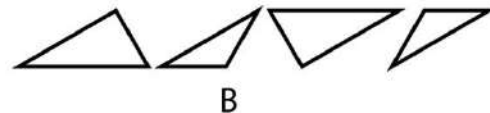

Q.57 Five small triangles of equal size are fitted in a large triangle as shown below. Approximately what percentage (%) of area in the large triangle is **empty**?

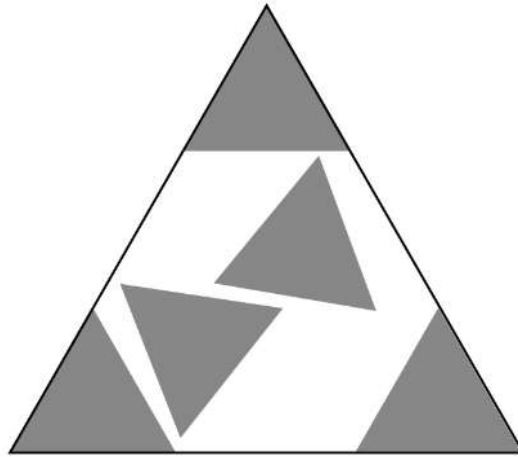

- A. 33
- B. 44
- C. 55
- D. 66

Q.58 The image below shows the developed surface of a cube. Which of the options will **NOT** open up as the shown image?

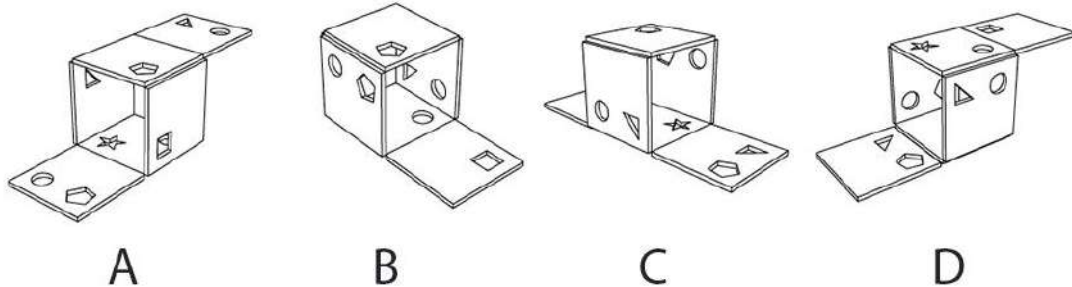
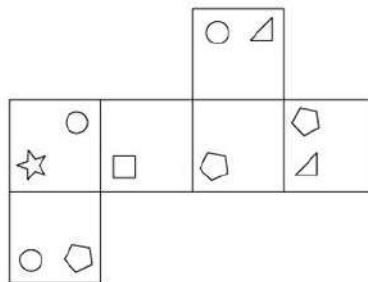

Q.59 A frame of a bouncing ball is shown in the picture. This shows the animation principle of __

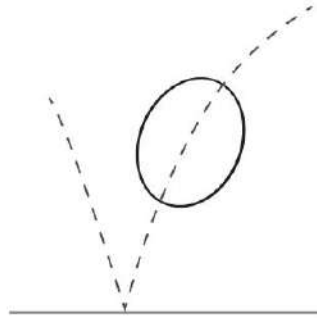

- A. Stretching Principle
- B. Distortion Principle
- C. Squash and Stretch Principle
- D. Motion Principle

Q.60 Two paper loops are joined together as shown in the figure below. If you cut the loops along the blue dotted line, what will be the resultant figure?

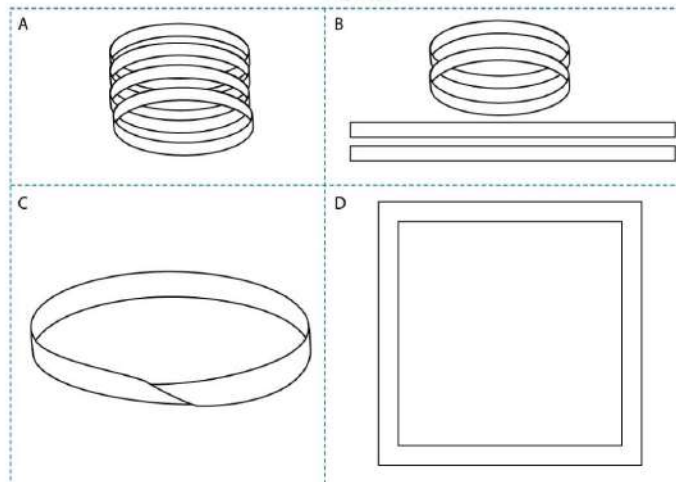
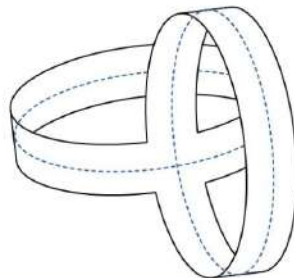

Q.61 Reference image of a square pyramid, P, is provided on the left. Assume Q as an identical pyramid created by mirroring P in upward direction. Q was rotated by 135 degrees around the vertical axis and then brought down so that the two pyramids intersect. Which of the options is the resultant view as seen from the given direction arrow?

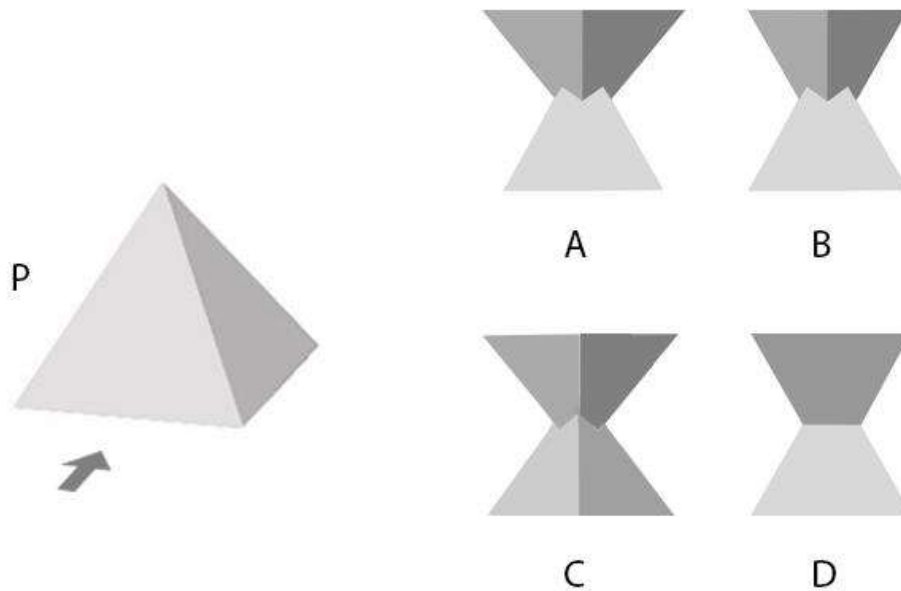

Q.62 Figure shows the top view of a cylinder with mirror finish kept on a paper on which the word 'WARD' is written. Which of following images is the best representation of the word and its reflection?

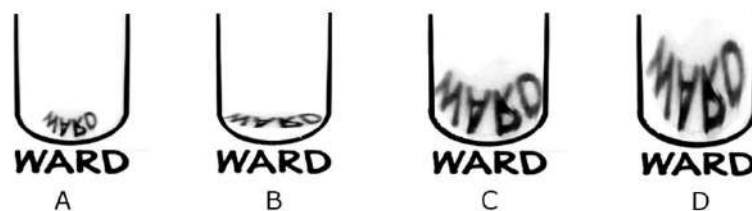

Q.63 Which letter is **NEVER** used while printing the calendar mentioning names of all the days of the week and months in full form?

- A. **W**
- B. **G**
- C. **K**
- D. **V**

Q.64 Which option depicts the reflection of the figure given below?



- | | | | |
|---|--|---|--|
| A | | C | |
| B | | D | |

Q.65 Three white squares overlap the cyan square such that one of their corners meet at the centre of the cyan square as shown in the figure. What is the ratio of the area of the shaded portion to the original cyan square?

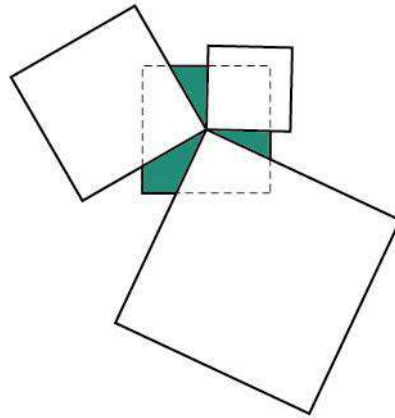

- A. 1/6
- B. 1/4
- C. 1/3
- D. 3/8

Q.66



- | | | | |
|---|--|---|--|
| A | | C | |
| B | | D | |

Q.67 **P, Q, R, S** are competing in the slow cycle race, in which the slowest cyclist wins. A few minutes after the race begins, **P** is physically ahead of **Q**. **R** and **S** are physically behind **Q**. **S** is physically ahead of **R**. **P** got eliminated and **R** overtakes **Q**. Just reaching before the end mark, **S** overtakes **Q**. Which of the options is true?

- A. **R** is winner
- B. **S** is winner
- C. **Q** is winner
- D. **Q** is runner up

Q.68 Select the correct logo



PART B

Mandatory question

Q.1 Sketching

(30 minutes – 60 marks)

[Note:

- 1) This question must be answered in the answer booklet provided by the invigilator
- 2) It is not mandatory for the candidates to mark the Part-B question as 'answered' at the bottom of the screen on the computer]

You are sitting in a well ventilated drawing room. It is 9 in the morning and sun light is streaming through the window on the East casting shadows on the floor. A cat is resting on one of the sunlit patches. A newspaper is placed beside a cup of hot tea on a small side table. There are three freshly watered potted plants in the room; one on the floor and two on the window sill with the watering jug next to it.

From the above description, sketch the scene from your point of view.

Note:

- Make pencil sketches only
- Do not use colours

Evaluation Criteria:

- Observation
- Imagination
- Selection & composition of objects
- Quality of line
- Presentation
- Attention to detail

UCEED 2020 ANSWER KEY

SECTION – A (NAT)

Q. No.	KEY RANGE	Q. No.	KEY RANGE	Q. No.	KEY RANGE	Q. No.	KEY RANGE	Q. No.	KEY RANGE
01	1020	02	33	03	27	04	21	05	140
06	16	07	9	08	10	09	8	10	17
11	3	12	16	13	365	14	4	15	2
16	7	17	44	18	2				

SECTION – B (MSQ)

Q.No.	KEYS	Q.No.	KEYS	Q.No.	KEYS	Q.No.	KEYS	Q.No.	KEYS
19	A, C	20	B	21	A, C, D	22	C, D	23	A, C
24	B, C, D	25	B, D	26	B, D	27	C, D	28	A, B, C
29	D	30	B, D	31	A, B, C	32	C, D	33	A, B, C
34	A, B, D	35	B, D	36	FULL MARKS				

SECTION – C (MCQ)

Q.No.	KEY	Q.No.	KEY	Q.No.	KEY	Q.No.	KEY	Q.No.	KEY
37	A	38	C	39	D	40	B	41	A
42	C	43	A	44	C	45	B	46	D
47	C	48	B	49	C	50	B	51	D
52	C	53	C	54	B	55	D	56	A
57	D	58	D	59	B	60	B	61	C
62	A	63	A	64	FULL MARKS	65	FULL MARKS	66	B
67	C	68	A						

Q36. Full marks are given to all the candidates as it is possible to have more than one solution

Q64. Full marks are given to all the candidates as it is possible to have more than one solution

Q65. Full marks are given to all the candidates as it is possible to have more than one solution

Undergraduate Common Entrance Examination for Design

UCEED 2020
QUESTION PAPER

Paper Specific Instructions

1. The total duration of the examination is 3 hours. The question paper contains two parts – Part A and Part B. The duration of Part A is **2 hours and 30 minutes**. Part B will begin after Part A ends. Part A is further divided into three sections, 1, 2 and 3. All sections are compulsory. Questions in each section are of different types. There are a total of **68 questions** carrying a total of 240 marks. Questions of Part A will appear on the computer. Answers to **Part A** have to be entered in the **computer**. **Part B** is also compulsory and contains **1 drawing question** of 60 marks.
2. Marking scheme of Part A is as follows:

Section	Number of questions	Marks for each correct answer	Marks for each wrong answer	Marks for each question not attempted	Total marks for the section
NAT	18	4	0	0	72
MSQ	18	4	-0.19	0	72
MCQ	32	3	-0.71	0	96
Total	68				240

3. **Section 1 (72 Marks)** of Part A contains a total of 18 **Numerical Answer Type (NAT)** questions. For each question, the answer is a **number** that needs to be entered using the virtual keyboard on the monitor. No choices will be shown for these questions. There is **NO NEGATIVE** marking for this section.
4. **Section 2 (72 Marks)** of Part A contains a total of 18 **Multiple Select Questions (MSQ)**. Each question may have **one or more than one correct choice(s)** out of the four given. A question is considered correctly answered if **ALL** the correct choices and **NO** wrong choices are selected for that question. There is **NEGATIVE** marking for this section. There is **NO PARTIAL** marking for this section.
5. **Section 3 (96 Marks)** of Part A contains a total of 32 **Multiple Choice Questions (MCQ)**. Each question has four choices out of which **ONLY ONE** is the correct answer. There is **NEGATIVE** marking for this section.
6. **Part B (60 Marks)** contains one drawing question. There is **NO NEGATIVE** marking in this section. Answers to **Part B** have to be given in the **answer book** provided by the invigilator.
7. Calculators, charts, graph-sheets, mathematical tables, mobile phone, smart watches and/or other electronic gadgets are **NOT** allowed in the examination hall.
8. Blank sheets of paper will be provided for rough work.

PART A

Section 1: Numerical Answer Type (NAT) questions

*Section 1 (72 Marks) of Part A contains a total of 18 Numerical Answer Type (NAT) questions. For each question, the answer is a real number that needs to be entered using the virtual keyboard on the monitor. No choices will be shown for these questions. There is **NO NEGATIVE** marking for this section. Each correct answer will be awarded 4 marks. Questions not attempted or answered incorrectly will be given zero mark. Questions from 1 to 18 belong to this section.*

- Q.01** The figure shows illustrations of six metal rods which have internal or external screw thread patterns at their ends. The shaded portion in the figure shows the cross section view. What is the maximum length possible by connecting the rods? Threads cannot be connected partially.

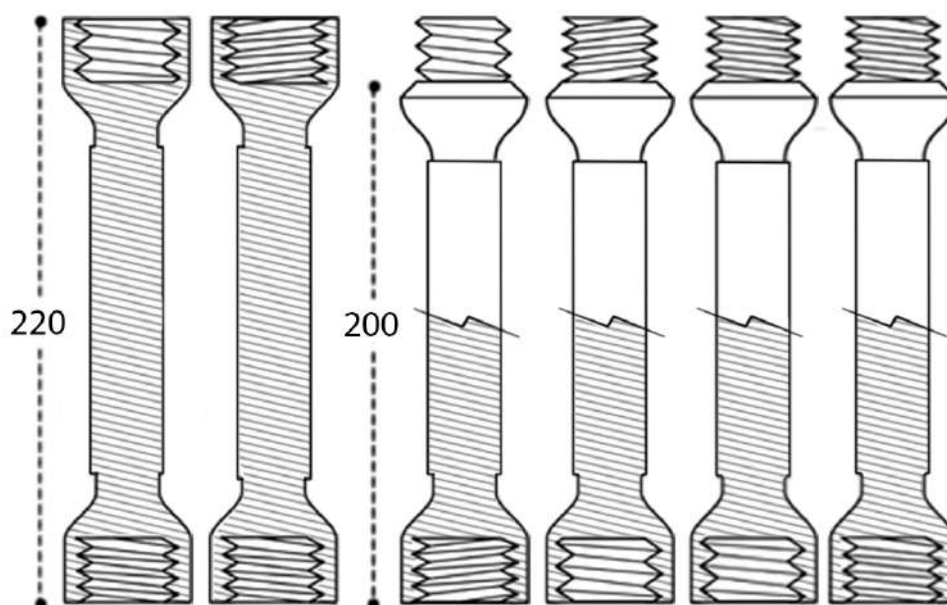

Q.02 The attached image shows a corridor floor that is covered with square tiles of the same size. How many tiles are covered by the green patch?

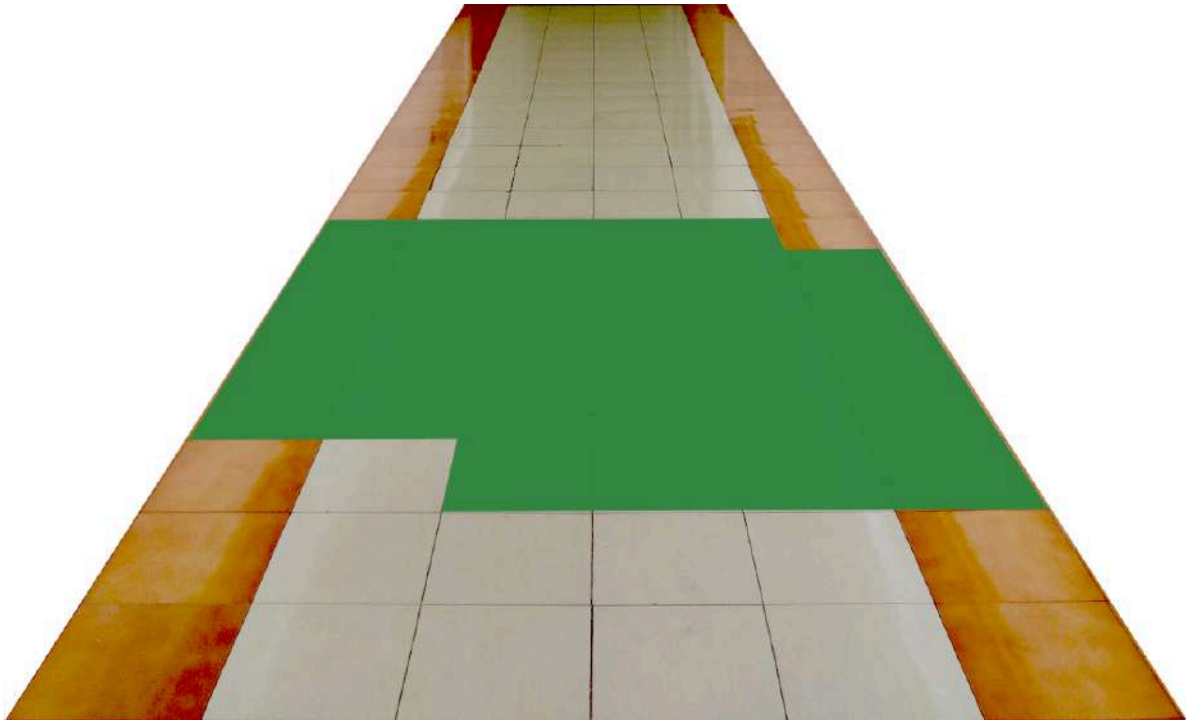

Q.03 Figure to the left shows an unfolded pattern of a die. If four such identical dice are stacked one on top of another, as shown on the right, what is the sum of the numbers appearing on the faces which are parallel to the ground?

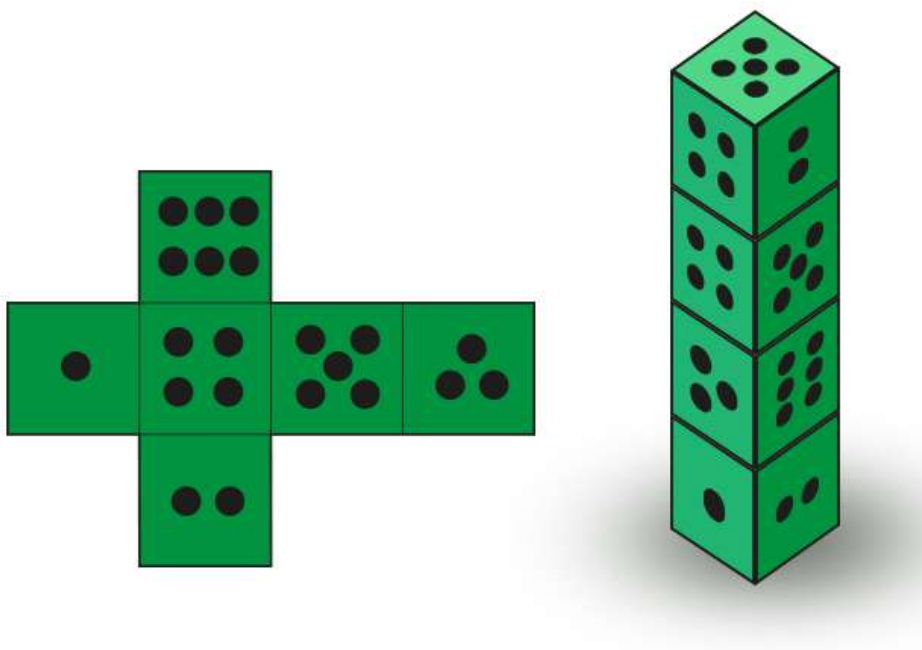

Q.04 Twenty points are arranged on a plane as shown in the figure below. What is the highest number of squares that can be drawn using any four points as corners?

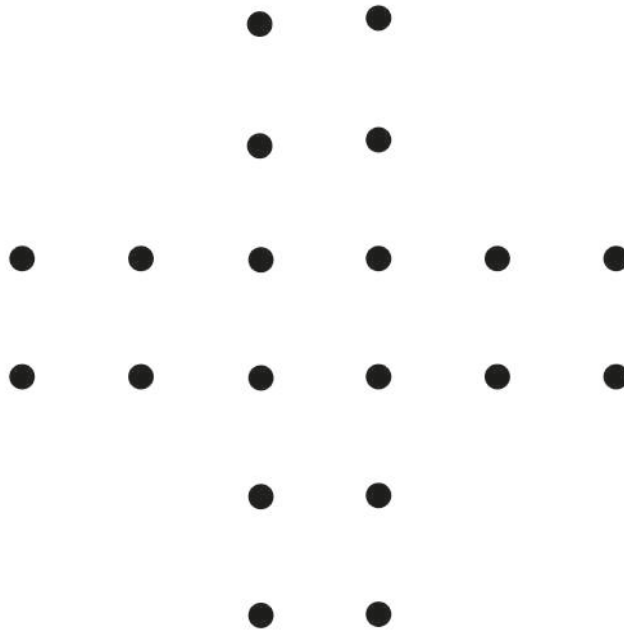

Q.05 Area of black surface in the following image is _____ cm^2 .

Note: 1. All curves have same radii. 2. Use the value of π as $22/7$

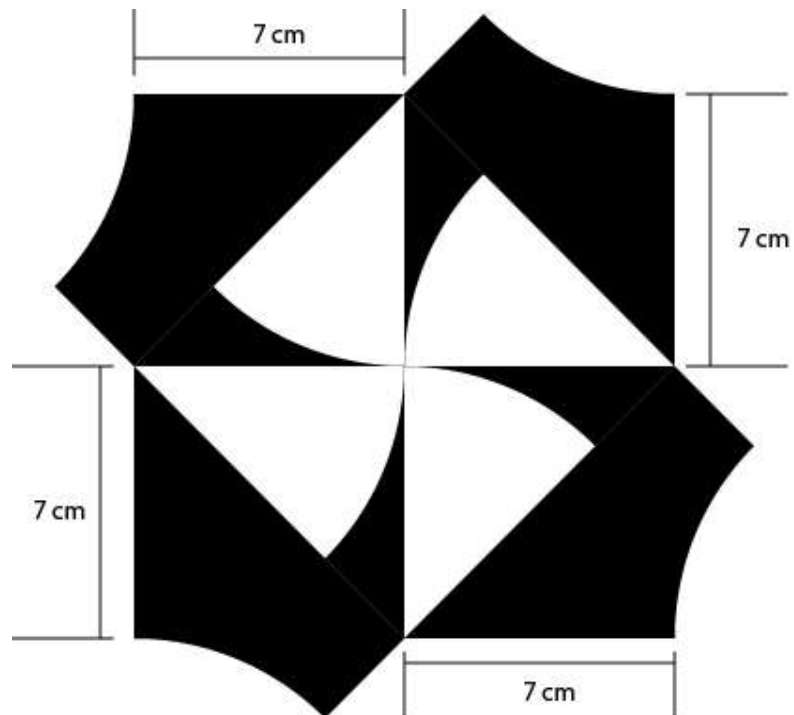

- Q.06** The image is a ceramic tile of dimension 20 cm x 20 cm. How many distinct patterns can you create by using two such ceramic tiles in a rectangular patch of 40 cm x 20 cm on the wall?

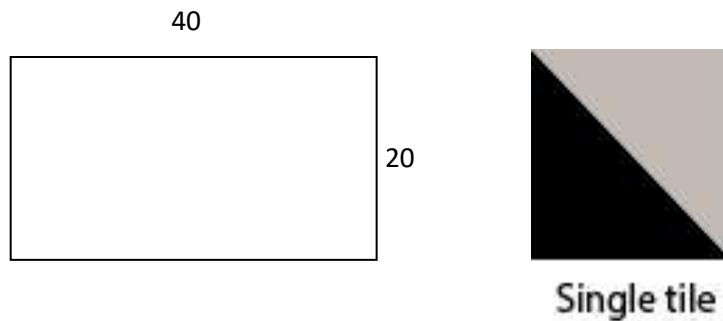

- Q.07** A cube is created by stacking 27 smaller cubes as shown in the figure. A plane, going through vertices A, B and C, cuts the cube as shown in the figure. How many smaller cubes will get cut?

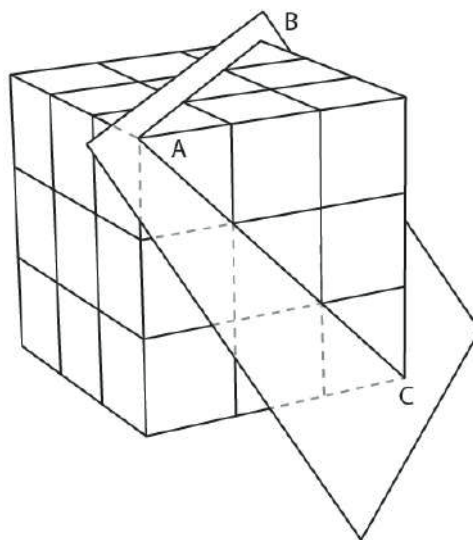

Q.08 At most how many triangles can appear by adding two straight lines to the figure?

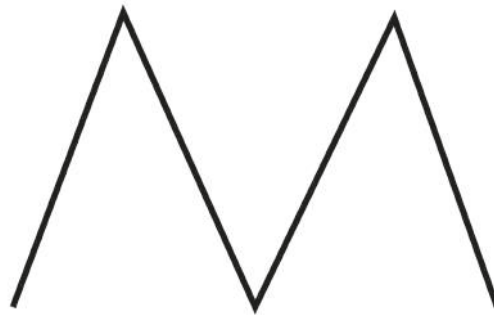

Q.09 How many distinct motifs appear in the figure on the right? Flips and rotations are to be counted separately, for example the motifs P and Q are distinct.

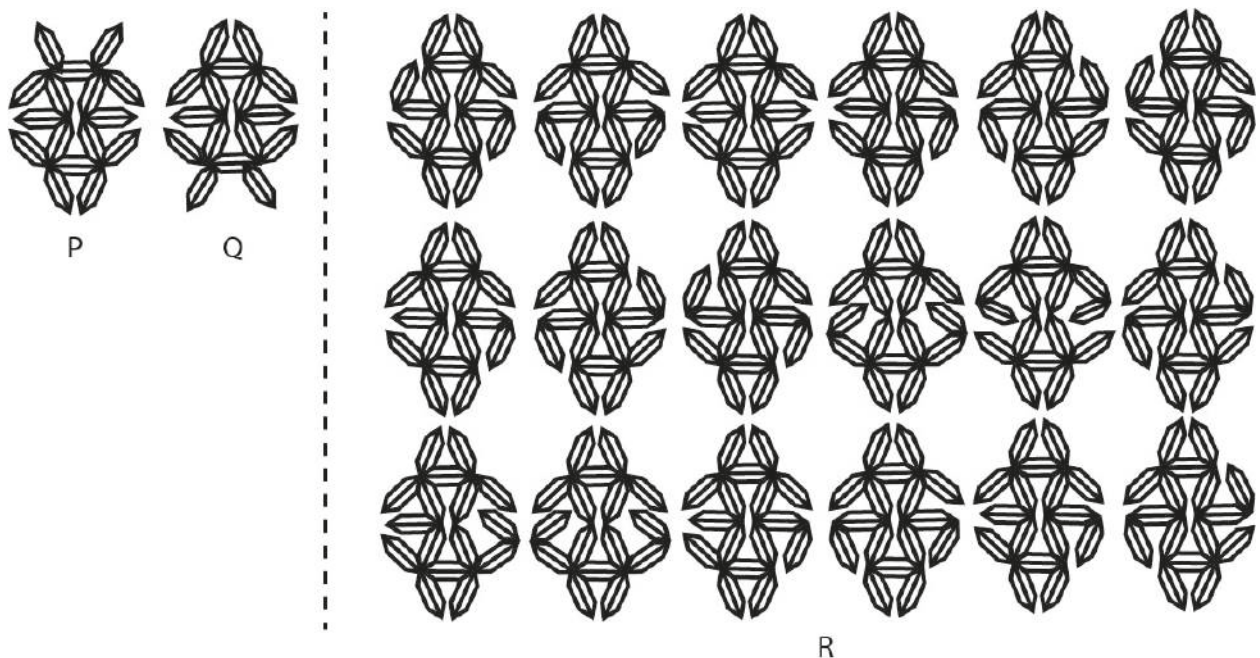

Q.10 A family of four—grandfather, father, son and daughter—are caught in a heavy rain and are stranded at a bus stop close to their home. However they have only one umbrella with them. The umbrella can take a maximum of two people without either of them getting wet. The four members of the family take different times to walk from bus stop to home. The grandfather is slowest of all, taking 10 minutes, followed by the father who takes 5 minutes. The son takes 2 minutes, while the daughter takes only a minute. What is the minimum total time (in minutes) for all four members of the family to reach home without any of them getting wet?

- Q.11** Six cards are laid out on a table as shown in the figure below. Each of the cards has a number on one side and a letter on the other side. What is the minimum number of cards you need to flip and see to make sure the rule, “cards that have a vowel on one side always have an even number on the other side” is TRUE?



- Q.12** X1 is a 3D form generated from the shape X, using certain 3D operations. It has 14 surfaces in total. If the same operations are carried out on shape Y, how many surfaces would the resulting 3D form have?

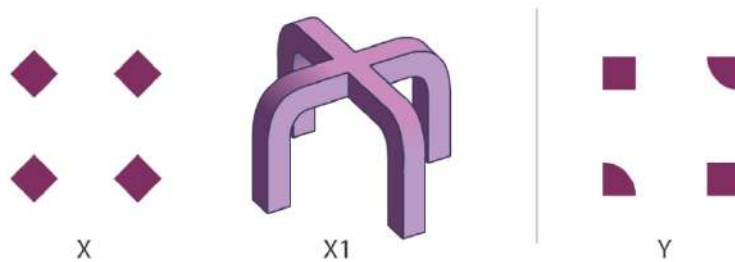

- Q.13** In 2018, a person spent half the time working, a third in sleeping and one-eighth in cooking. He spent the rest of the time exercising. How many total hours did he spend exercising?

- Q.14** If the given shape in the figure is used to tile the grid on the right without any overlaps, what is the minimum number of units that will be left uncovered? Flips and rotations are allowed.

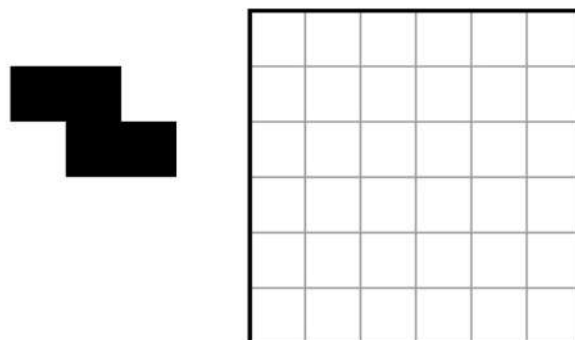

Q.15 A rectangular wooden plank has another smaller rectangular hole cut into it as shown in the figure given below. What is the minimum number of cutting planes that can divide the wooden plank into four parts of equal volume?

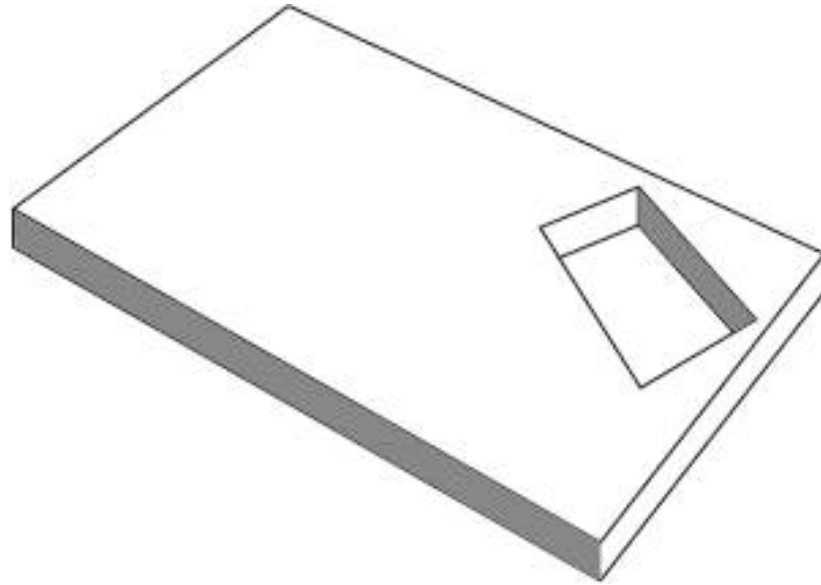

Q.16 Count the number of differences between the two images shown below.

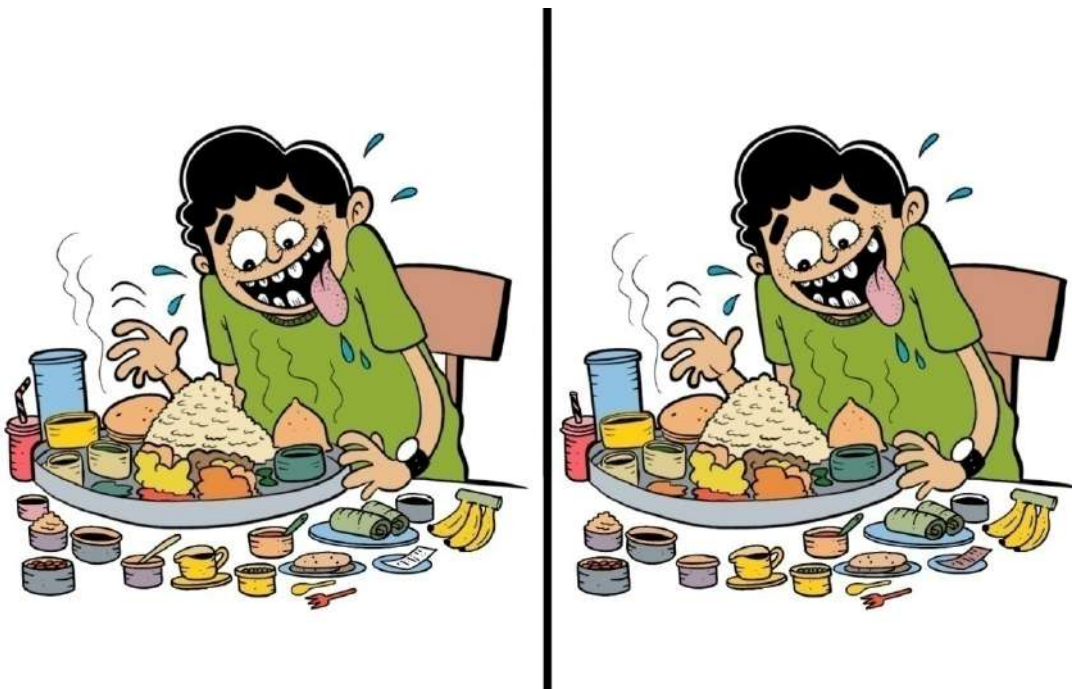

Q.17 An intersection is where two or more lines and/or curves meet or cross. How many intersections are there in the figure?

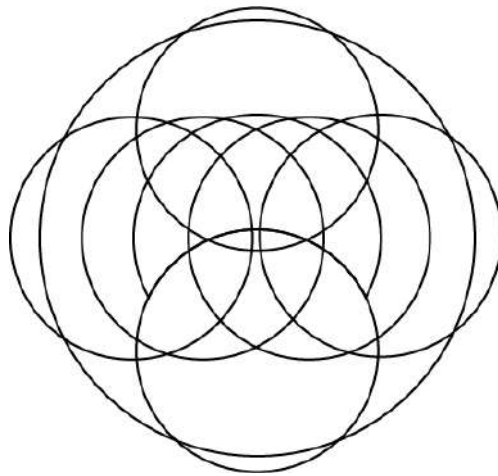

Q.18 There are different types of pineapples in the given figure. How many pineapples appear only once?

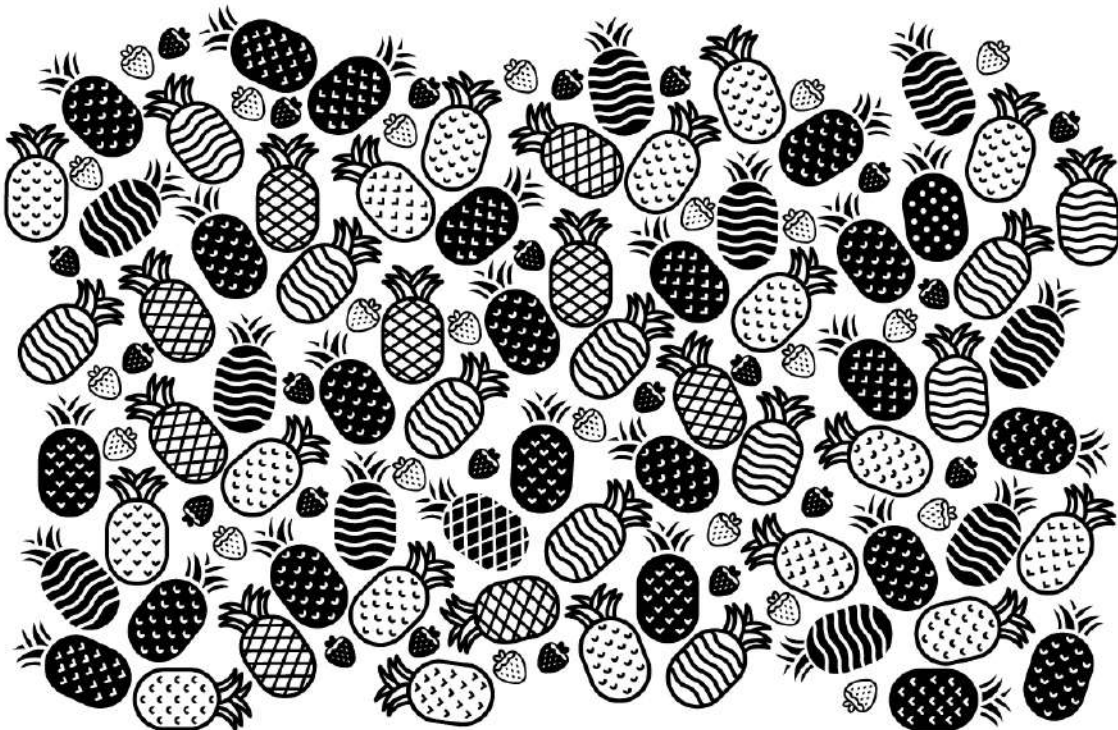

Section 2: Multiple Select Questions (MSQ)

Section 2 (72 Marks) of Part A contains a total of 18 **Multiple Select Questions (MSQ)**. Each question may have **one or more than one correct choice(s)** out of the four given. A question is considered correctly answered if **ALL** the correct choices and **NO** wrong choices are selected for that question. There is **NEGATIVE** marking for this section. Each question answered correctly will receive 4 marks. Each question wrongly answered will receive -0.19 (minus zero point one nine) mark. There is **NO PARTIAL** marking for this section. Questions not attempted will be given zero mark. Questions from 19 to 36 belong to this section.

- Q.19** Two transparent discs with markings on them are shown. Which of the options can be created by overlapping and/or rotating them?

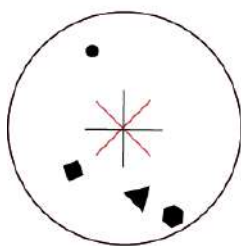
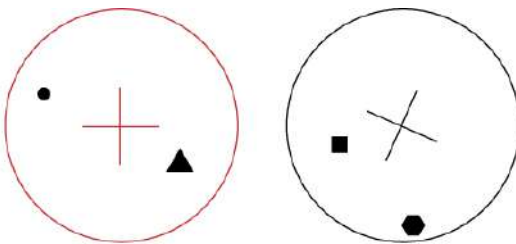

A

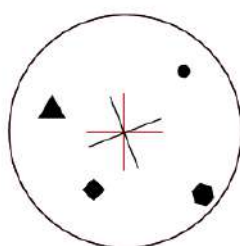

B

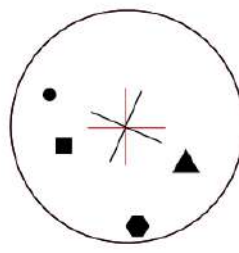

C

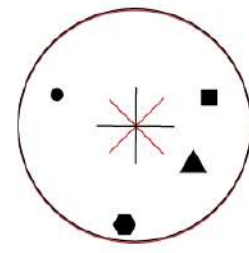

D

Q.20 Read the paragraph given below and answer the question that follows:

... Turkle describes the computer as an evocative object, one that raises new questions regarding our common sense of the distinction between artefacts and intelligent others. Her studies include an examination of the impact of computer-based artefacts on children's conceptions of the difference between categories such as "alive" versus "not alive" and "machine" versus "person." In dealing with the questions that computer-based objects evoke, children make clear that the differentiation of physical from psychological entities, which as adults we largely take for granted, is the end product of a process of establishing the relationship between the observable behaviour of a thing and its underlying nature. Children have a tendency, for example, to attribute life to physical objects on the basis of behaviours such as autonomous motion or reactivity, though they reserve humanity for entities evidencing such things as emotion, speech, and apparent thought or purposefulness. Turkle's observation with respect to computational artefacts is that children ascribe to them an "almost aliveness" and a psychology, while maintaining their distinctness from human beings: a view that, as Turkle points out, is remarkable among other things for its correspondence to the views held by those who are the artefacts' designers.

Which of the following statements is/are TRUE of the paragraph above?

- A. Turkle argues that children get confused when encountering computational artefacts and mistake them as human-like
- B. Turkle argues that children are able to differentiate between physical and psychological entities by establishing relationship between how a thing behaves and its nature
- C. Turkle concludes that children and adults react and categorise computer-based artefacts in a similar manner
- D. Turkle finally concludes that children have a hard time understanding computer artefacts whereas adults can understand these artefacts far more easily.

Q.21 Shown below is a T-shaped image on a transparent sheet of paper. Which of the options IS/ARE made by overlapping and/or rotating multiple copies of the transparent sheet?

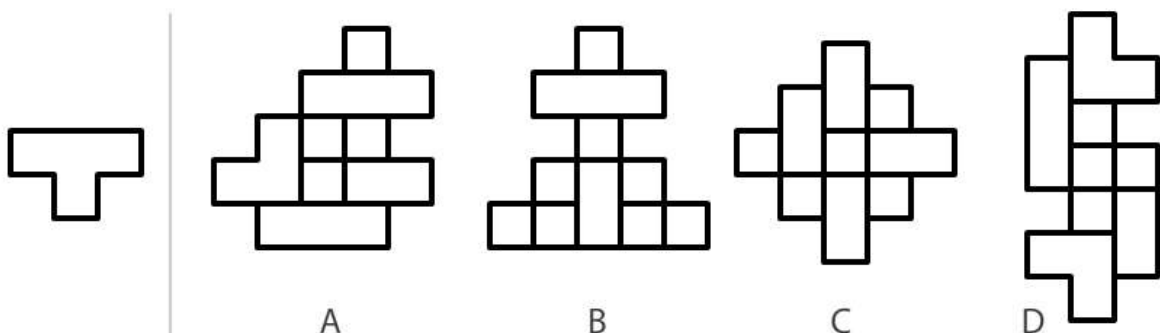

Q.22 Five friends Puru, Qadir, Roy, Sham and Tom live on five vertices of a regular pentagonal ground in a clockwise order. One day while Puru was walking to meet Roy, met Qadir who was on the way to meet Tom. Qadir changed his mind and decided to go with Puru to meet Roy. After meeting Roy all three went to Tom's house for a cup of tea.

If all of them took shortest routes cutting through the ground, which of the following statements is/are TRUE?

- A. Till Tom's place, Qadir walked more distance than Puru
- B. Till Tom's place, Puru walked more distance than Qadir
- C. Till Tom's place, Qadir walked double the distance than Roy
- D. While returning to their respective homes from Tom's place, Puru has to travel the least.

Q.23 A sphere, a cylinder and a cone, with equal heights are resting on a surface along a straight line. If the source of light is fixed and the light rays are parallel, which of the options show(s) the shadows correctly?

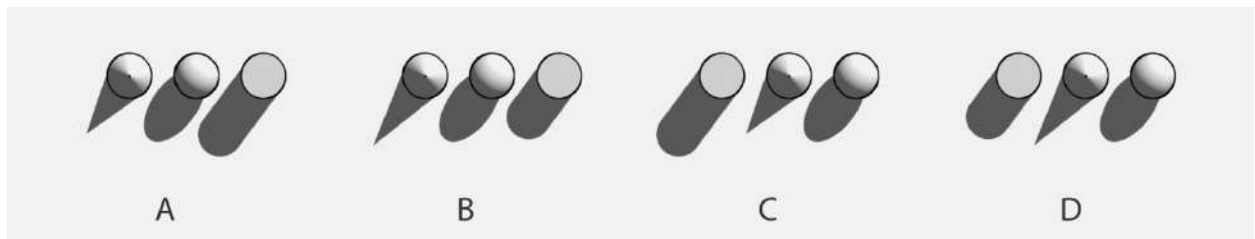

- Q.24** Which of the following statements would you consider to be TRUE about the hour and minute hands of analogue clocks?
- The hour hand and the minute hand would make 90 degrees angle with each other 24 times in a day
 - The hour hand and minute hand will overlap less than 24 times in a day
 - The hour hand and minute hand will overlap exactly on the hour number marker only once every half a day
 - The hour hand and minute hand will make acute angle to each other for almost as long as it will make obtuse angle to each other during the entire day

- Q.25** Two friendly bugs were on their usual walk in the north-east direction. When the sun was in the east, they had an argument and one of them turned 45 degrees anticlockwise and walked away. Which of the images below correctly represent(s) their shadow now, when viewed by a person from top?

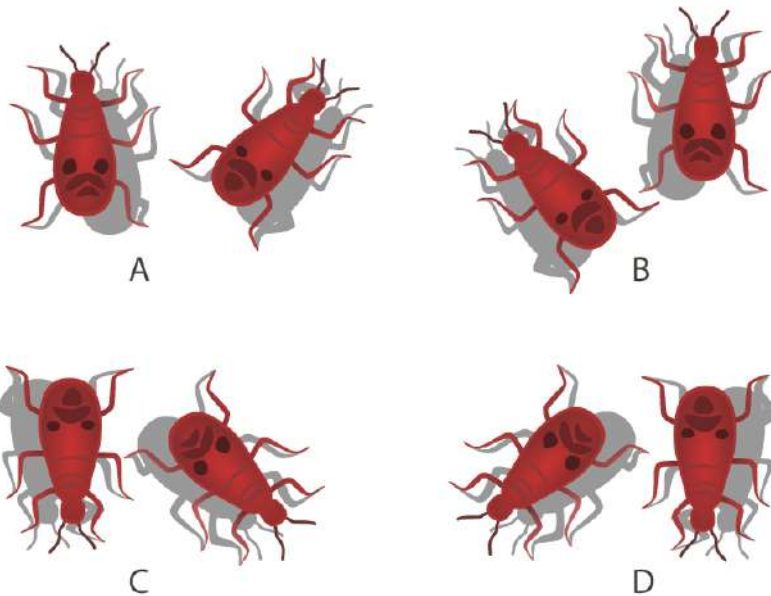

Q.26 A pencil with pentagonal cross-section was sharpened using a pencil sharpener. Which of the options correctly represent(s) side view of the pencil?

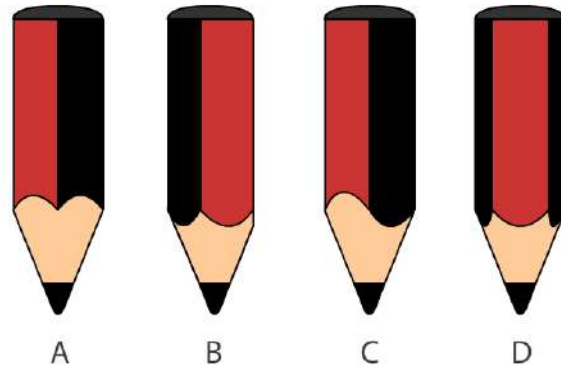

Q.27 A paper strip with a different colour on each side is joined as shown in the figure. If this strip is cut along the dashed line, which of the options correctly represent(s) the result(s)?

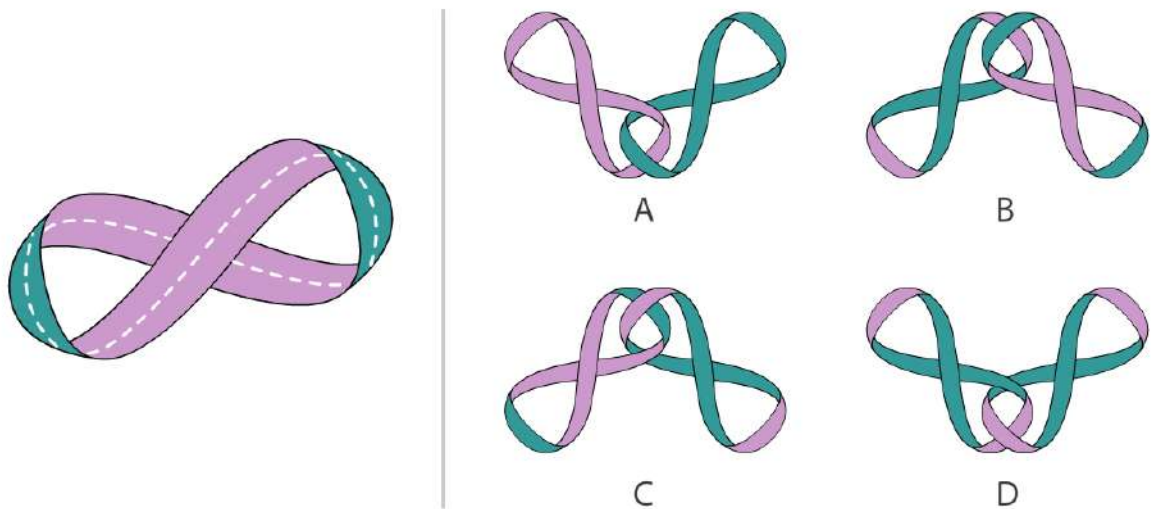

Q.28 Sundays are longer than Mondays. Mondays are shorter than Fridays. Wednesdays are shorter than Saturdays, which are in turn shorter than Sundays. Thursdays are shorter than Saturdays. Tuesdays are longer than Saturdays. Wednesdays and Thursdays are both longer than Fridays. If all of these are true, which of the options is/are also TRUE?

- A. Wednesdays could be as long as Thursdays.
- B. Tuesdays could be the longest days of the week.
- C. Mondays are the shortest days of the week.
- D. Fridays could be as long as Sundays.

Q.29 Which of the options CANNOT be folded along the dotted lines into a package as shown in the image? For simplicity sake, cut lines have not been shown in the given schematic. The cross section of the package is an equilateral triangle.

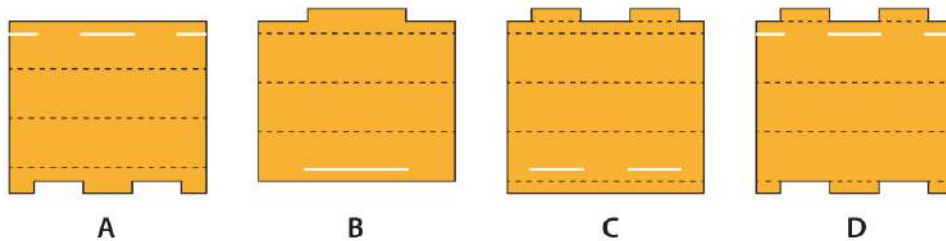
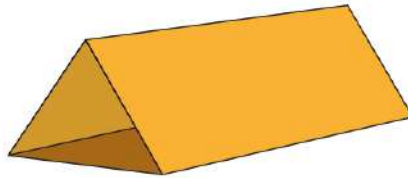

Q.30 Each of the options shows a pair of two different pieces. Which of the options CAN NOT be cut out of the given figure?

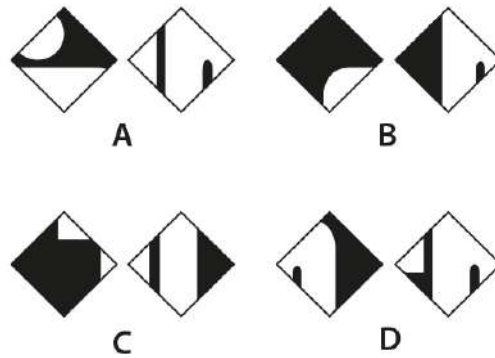

Q.31 Shown below is an image that represents how cups should stack on top of each other in a stable manner. Among the given different types of cups, which of the cups CANNOT stack on itself in a stable manner?

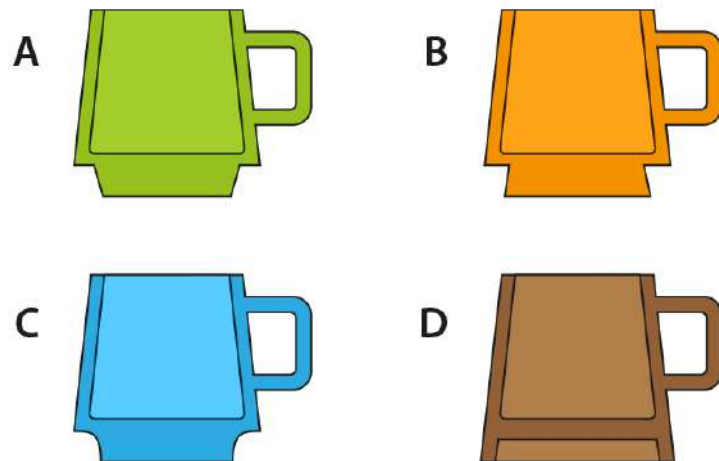
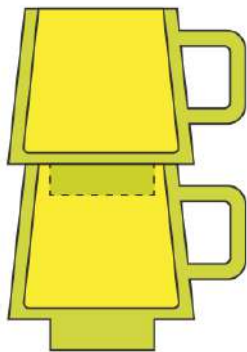

Q.32 In the image shown, objects have been duplicated and rotated. Which object(s) is/are NOT arranged around a perfect circle?

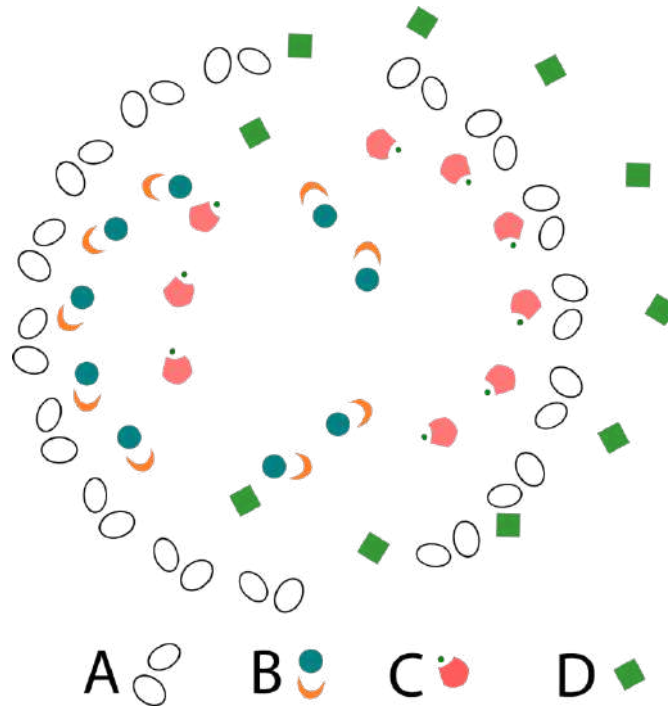

Q.33 Figures 2 and 3 can be derived from figure 1 by overlapping some of the given options one at a time. If flipping and rotations are allowed, which option(s) will allow you to derive figure 2 and 3?

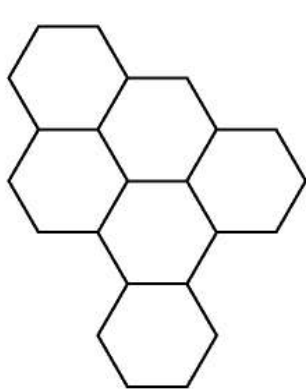

1

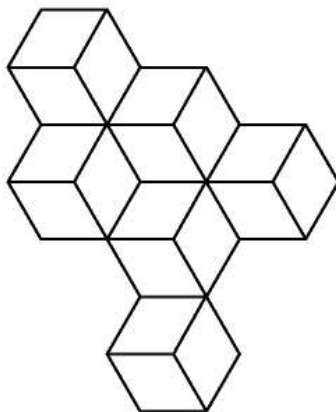

2

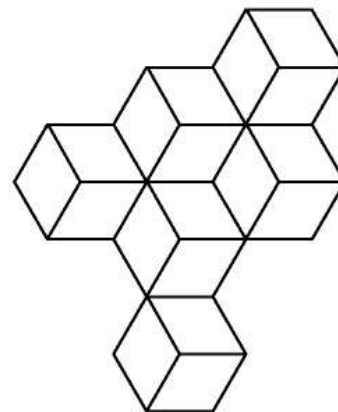

3

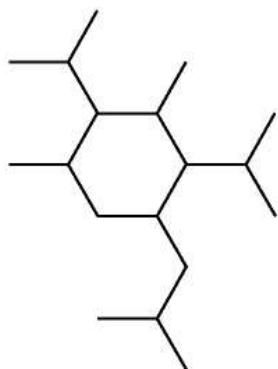

A

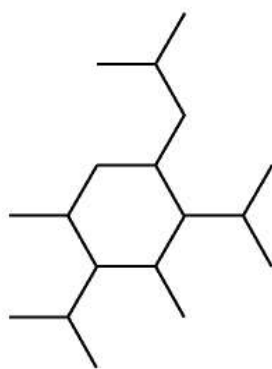

B

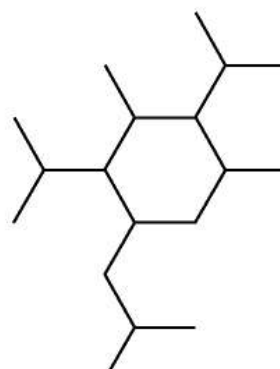

C

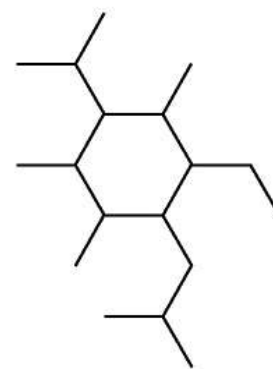

D

Q.34 P, Q, R, S, T, U and V are bees living in separate cells of a 2D hive made of hexagonal cells. T and V are neighbours of P. R and S are neighbours of U. V does not share a wall with T, U or R. Q, being the queen, shares a wall with everyone. Which of the options must be TRUE?

- A. S and V are neighbours
- B. R and T are neighbours
- C. P and U share a wall
- D. S and T are not neighbours

Q.35 The figures show four different schematics of two flexible strings. If all the ends are pulled tight, which of the options will form a knot?

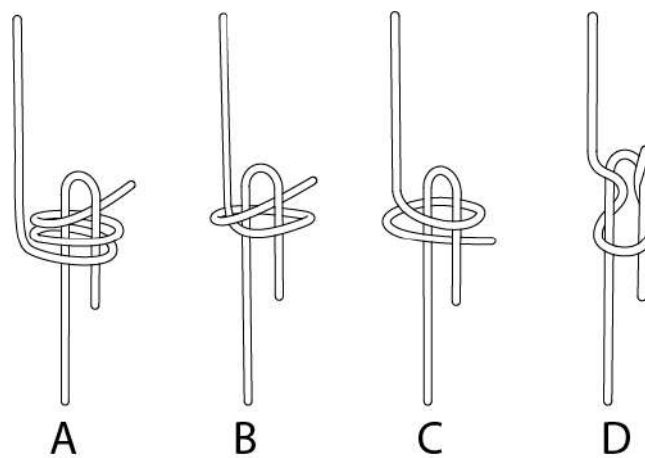

Q.36 Seven identical playing dice are unfolded in an identical manner. Six of the unfolded dice are laid out on a flat surface and are arranged to touch each other without overlapping. The figure shows a portion of the arrangement. Which face(s) from the seventh unfolded dice CAN NOT replace X if overlap must be avoided?

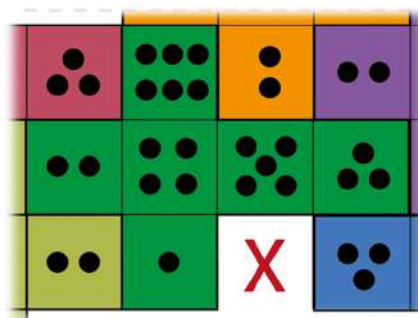

- A.
- B.
- C.
- D.

Section 3: Multiple Choice Questions (MCQ)

Section 3 (96 Marks) of Part A contains a total of 32 **Multiple Choice Questions (MCQ)**. Each question has four choices out of which **ONLY ONE** is the correct answer. There is **NEGATIVE** marking for this section. Each correct answer will be awarded 3 marks and each wrong answer will receive -0.71 (minus point seven one) mark. Questions not attempted will be given zero mark. Questions from 37 to 68 belong to this section.

Q.37 Which option will replace the question mark?

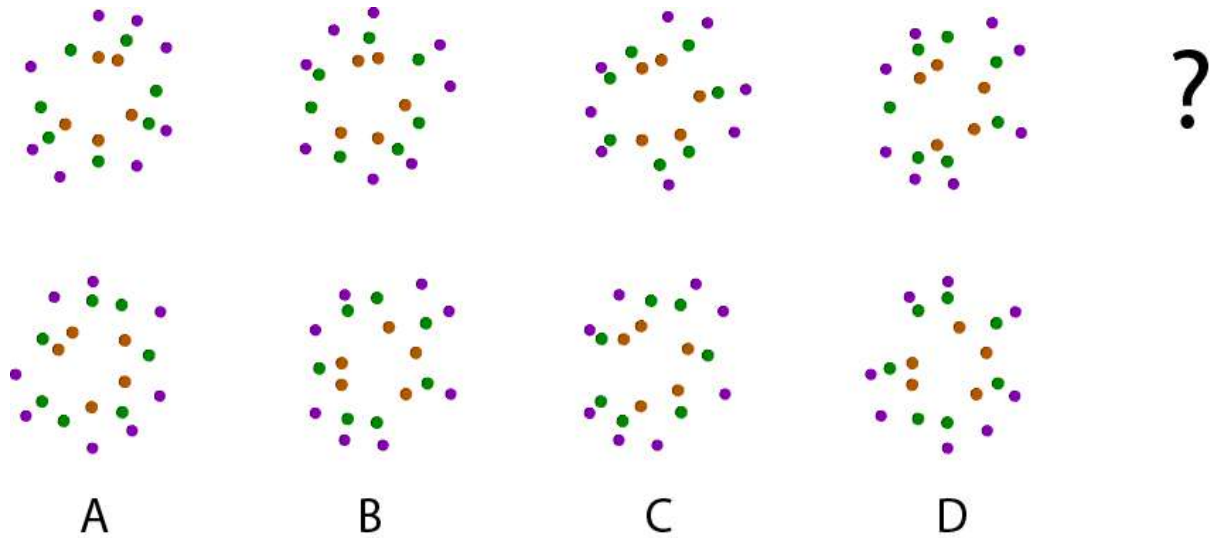

Q.38 A paper strip is rolled and then cut with two planes at 45 degree as shown below. The middle part of the cut paper is unrolled. Which of the options represents this part?

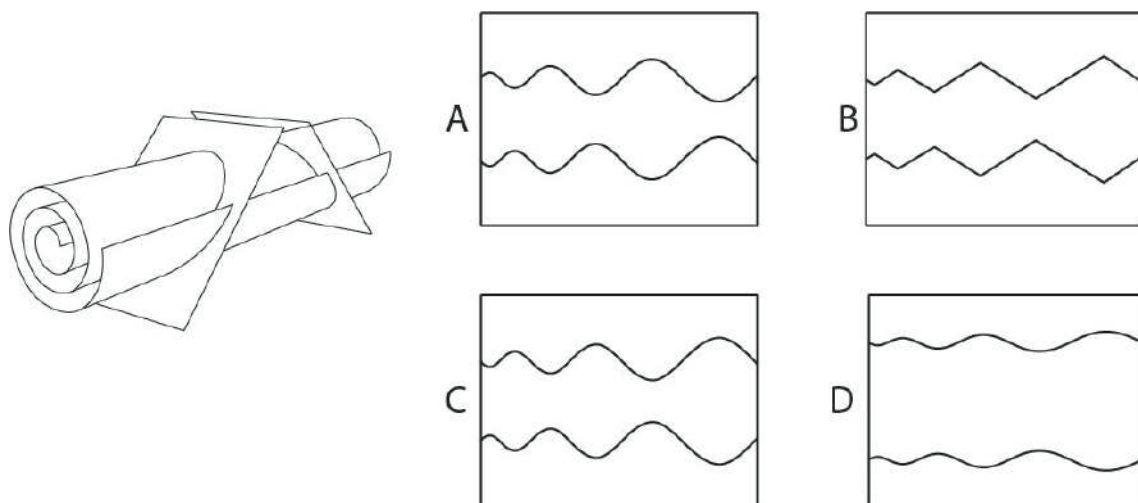

Q.39 The phrase shown below uses a particular font. Which of the options belongs to the same font?

มโหฬาร นชราต

ศย

A

ศย

B

ศย

C

ศย

D

Q.40 Aastha is sailing a paper boat in still water. Which of the given options represents the reflection correctly?



Q.41 An illustration of a walking ant and a pair of glasses lying on the table surface is shown. Which is the correct illustration from the ant's current point of view?

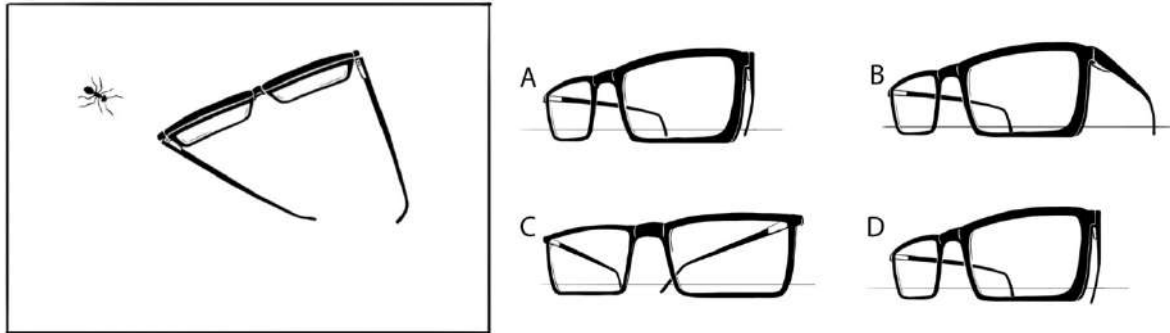

Q.42 If *drassoglitive* means *woodboard*
frassopoolts means *bodystudy*
glitivedrassy means *foodwood*
dressowoolts means *digitalscreen*

Then which word would mean *screensize*

- A. dressoissics
- B. dressodrasso
- C. issicsdresso
- D. drassodresso

Q.43 A rolled yellow paper cylinder is rotating clockwise direction at a constant rate of 1 revolution / 60 seconds. A pencil is touching the paper cylinder and is moving from T1 to T2 in 10 seconds and stops for 10 seconds. Then it moves to T3 in next 40 seconds (total time=60 seconds) as shown in figure 2. What would be the graph on paper when it is unrolled?

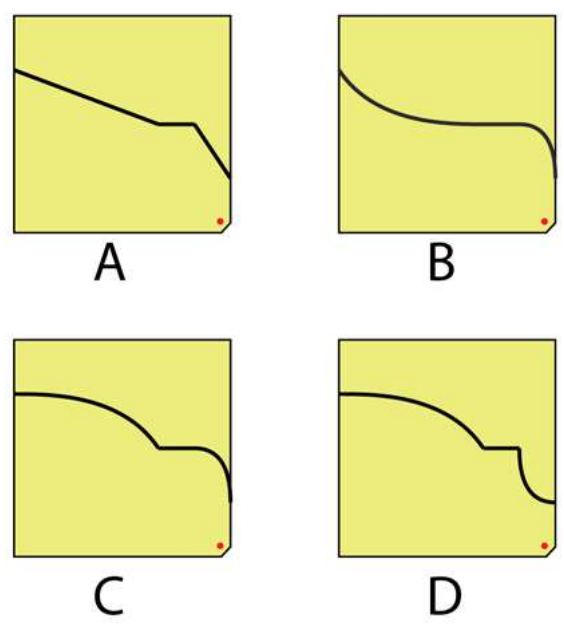
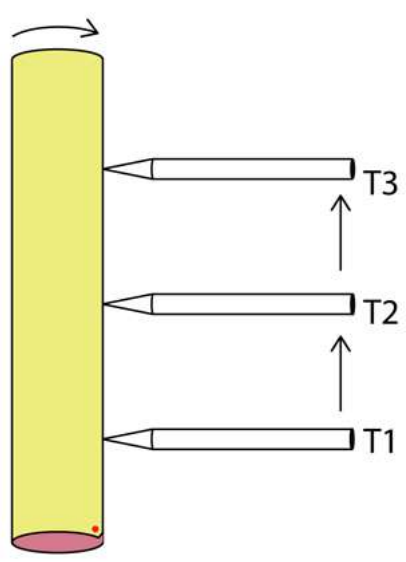

Q.44 An opaque circular disc is parallel to the table top. A beam of sunlight casts its shadow on the table top as shown in the figure. Which of the options represents the shape of the shadow as seen in the top view of the table?

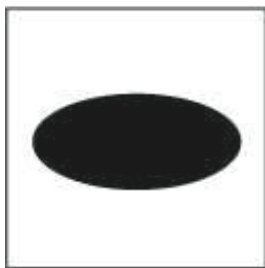
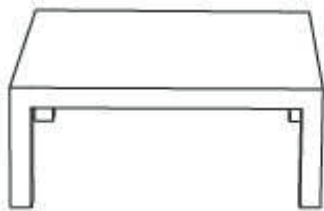

A

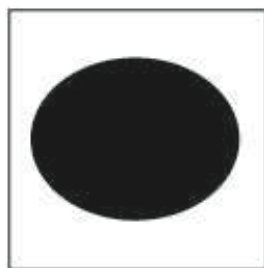

B

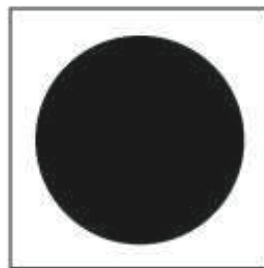

C

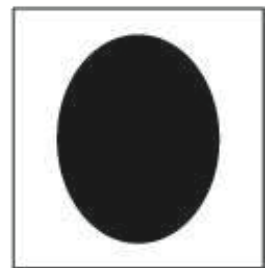

D

Q.45 In a given version of chess, no piece can capture another piece. Instead, each piece is on a mission. In the scenario shown in the figure on the left, the knight is on a mission to the diagonally opposite square marked by X. Assuming that no other piece moves, what is the minimum number of moves it will take the knight to reach there? (Note: In chess, the knight moves as shown in the figure on the right. The knight cannot land on any square that has a pawn, but can jump over it.)

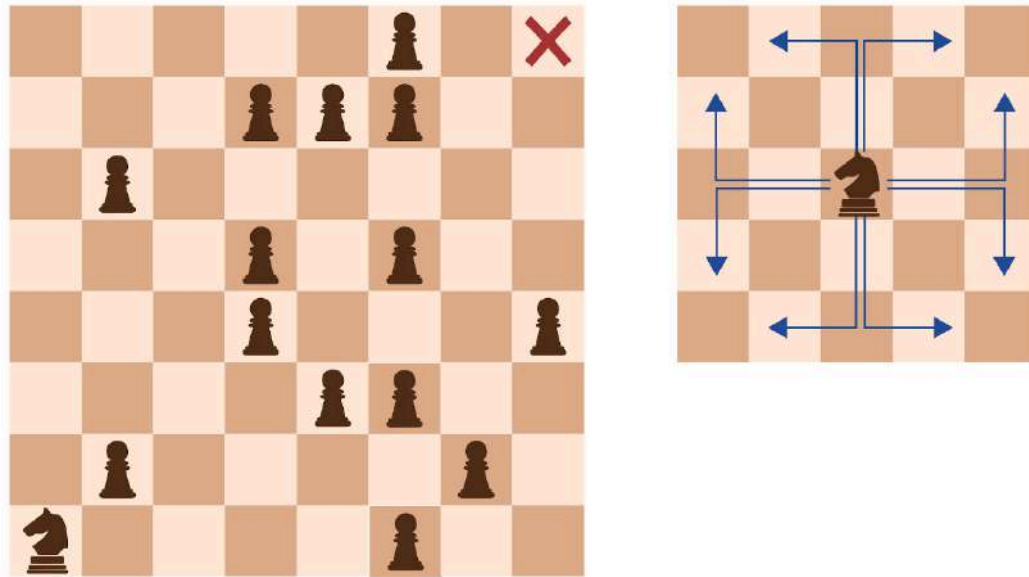

- A. 5
- B. 6
- C. 7
- D. 8

Q.46 Three options are made out of the same set of pieces WITHOUT flipping. Which of the options is NOT possible?

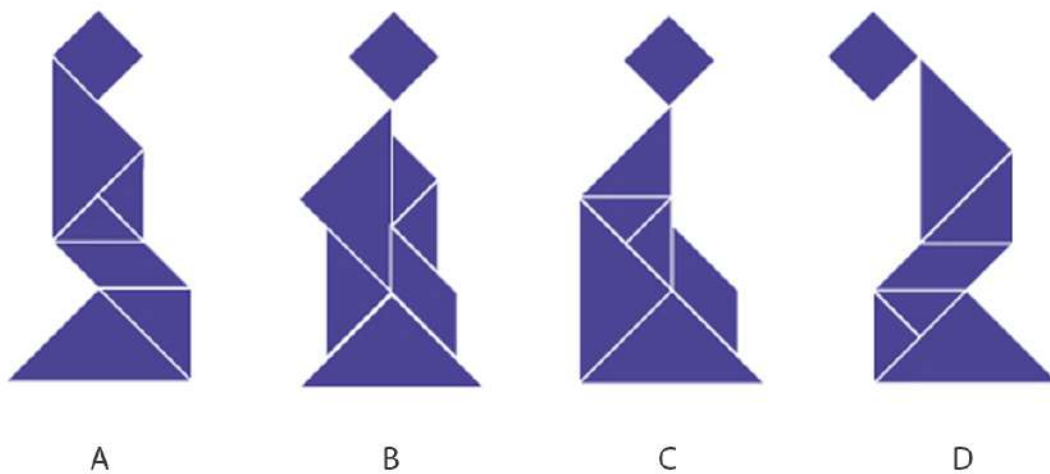

Q.47 A 10 cm tall card with some cut-outs is placed on a long table in front of a lamp in a dark room as shown in the figure. The lamp is 15 cm tall and is placed 15 cm in front of the card. Which of the options shows the correct shadow cast by the card?

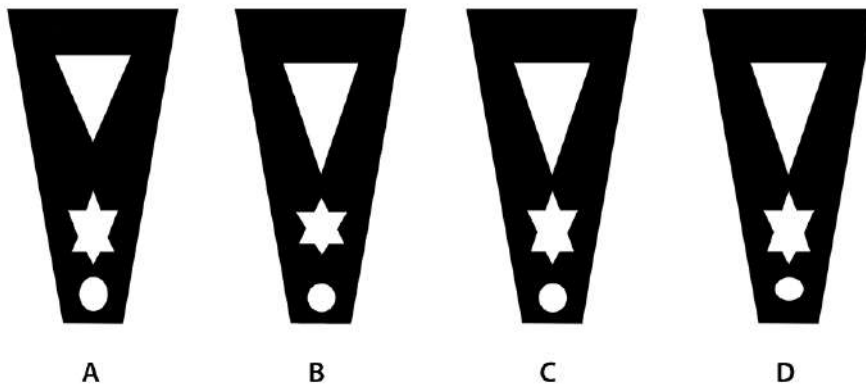
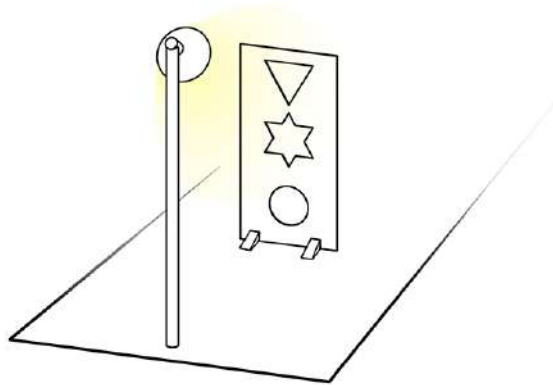

Q.48 Which is the odd one out?

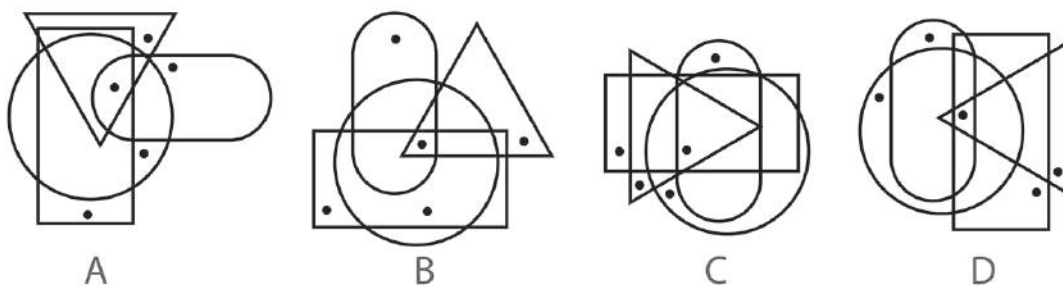

Q.49 Identify the correct set of legs for Mr. Kumar to balance his body as he carries a heavy box.

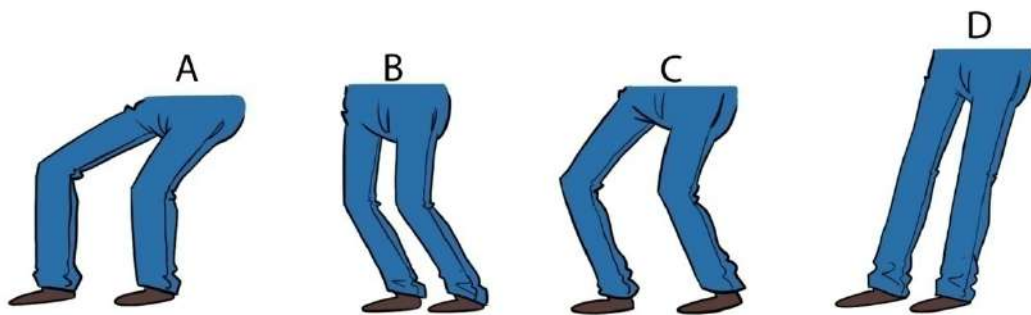

Q.50 Front and back views of a solid are shown. Which of the options can be folded to form this solid?

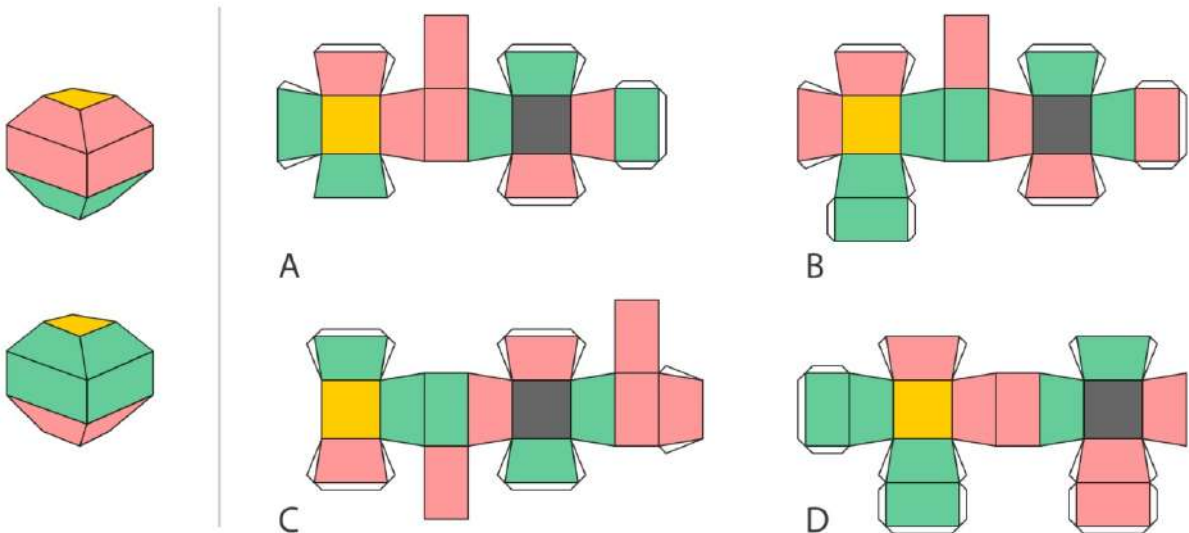

Q.51 Shown below is a paint splatter on a wall surface. A paint squeegee is pulled over it. Which of the options correctly represents the part of the pattern formed?

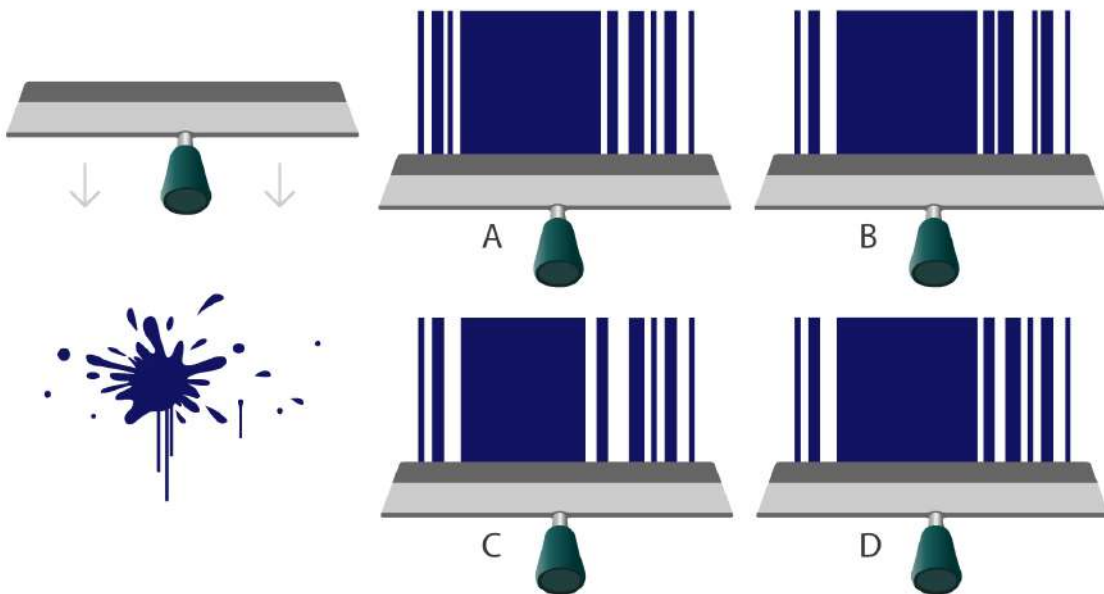

Q.52 The adjacent figure has six compartments. Each compartment consists of six squares. These squares are to be filled with six different colours in such a way that each row, each column and each compartment should have all six colours. Which of the options will replace the question marks?

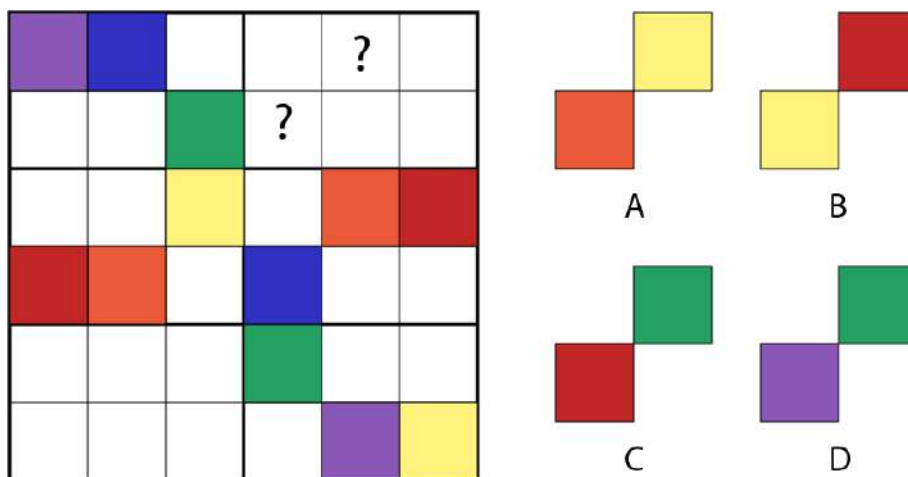

Q.53 A giant creature is walking towards a group of buildings in the city. Which is the correct perspective from the creature's point-of-view?

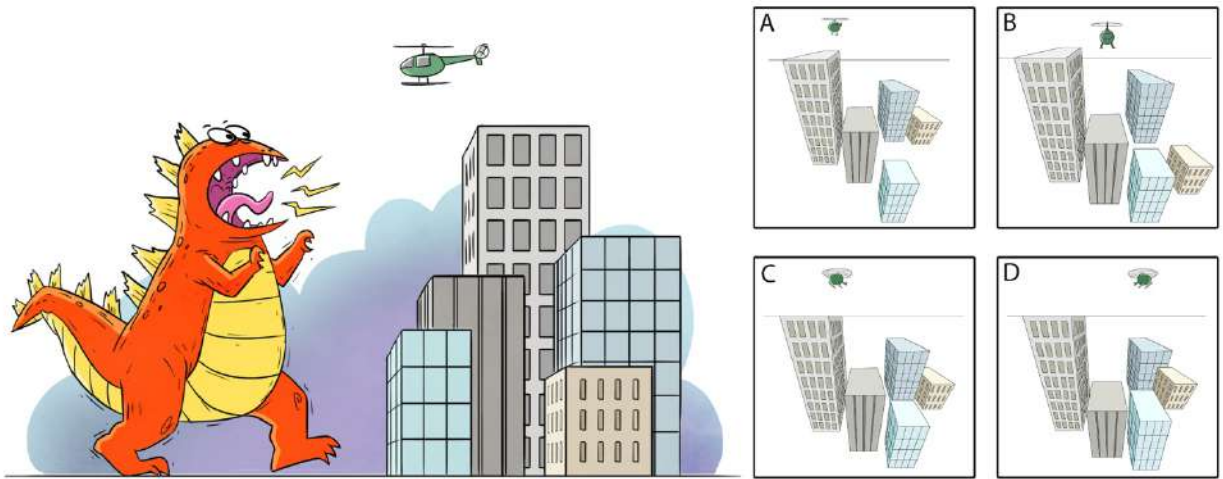

Q.54 Which of the options will replace the question mark?

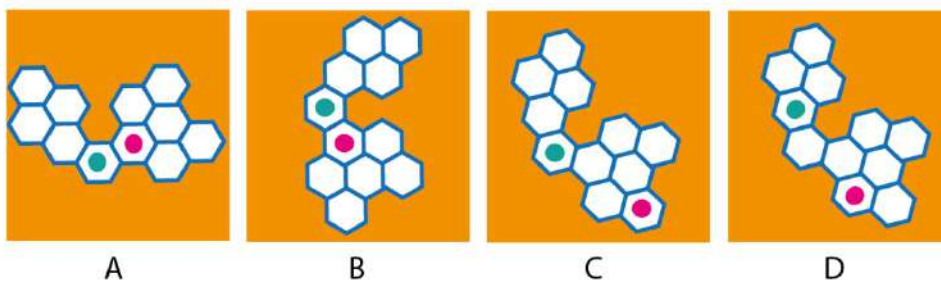

Q.55 The figure shows a mechanism with a disc, two bars and a static surface connected to each other with hinges. The disc rotates about the hinge at its centre as shown. What is the path traced by point X (end point of the longest bar) in this planar set up?

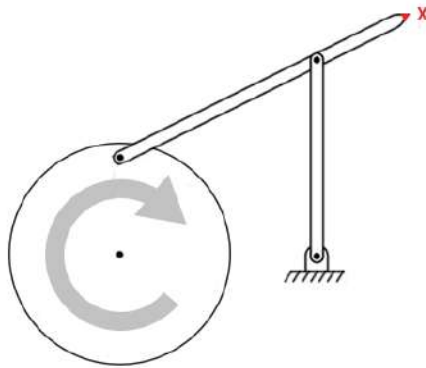

- A.
- B.
- C.
- D.

Q.56 Identify the correct representation of lighting for this scene, given that the lightening strike is the only light source.



Q.57 Which of the following lakes has the largest area?

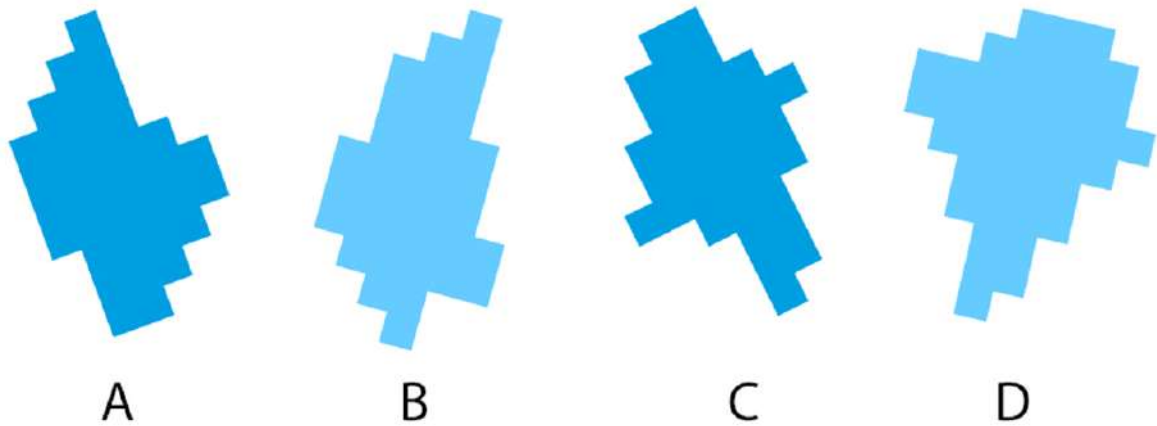

Q.58 Which of the given options matches the patterns (1,2,3,4) with tiles (P,Q,R,S) correctly?

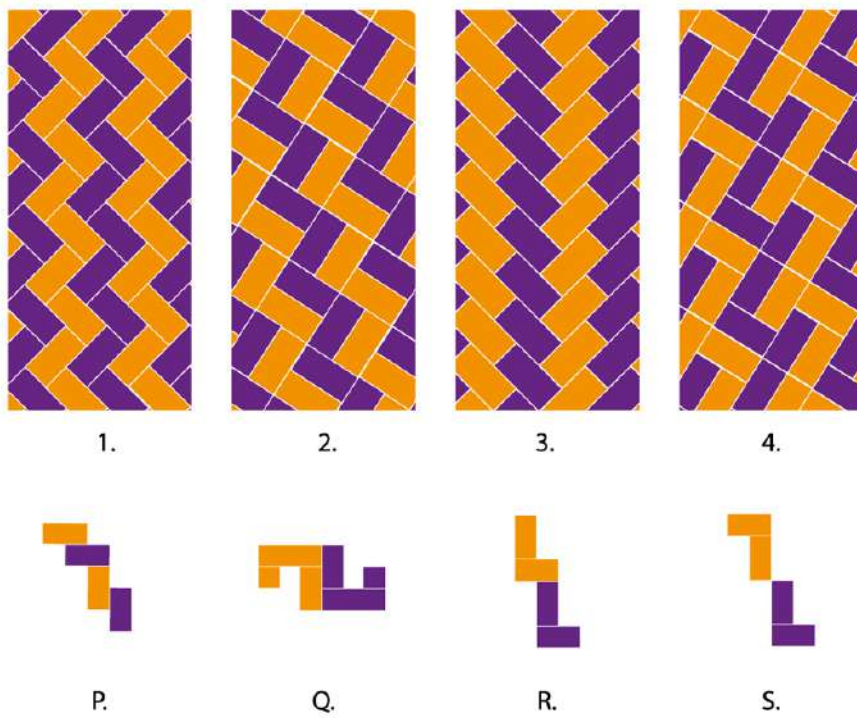

- A. 1-S, 2-P, 3-Q, 4-R
- B. 1-R, 2-Q, 3-P, 4-S
- C. 1-Q, 2-S, 3-R, 4-P
- D. 1-R, 2-S, 3-P, 4-Q

Q.59 Which of the options correctly shows the silhouettes of the given image?

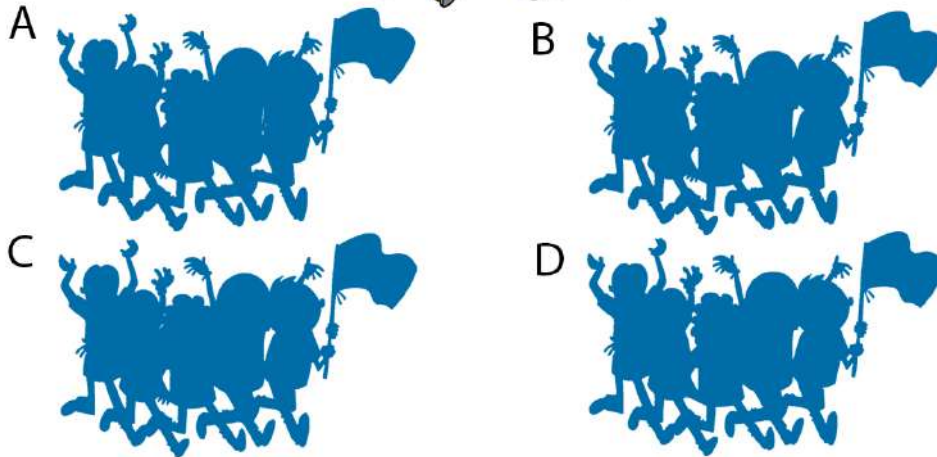

Q.60 Three rings are shown in the figure. They roll in the specified directions and stop when centres of all the rings coincide at line XX' . What pattern would they make?

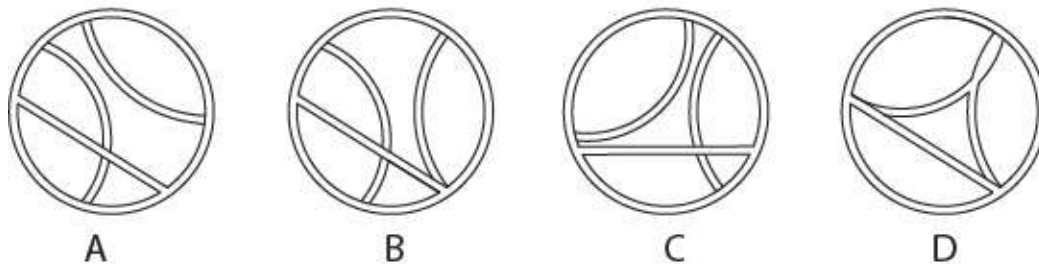
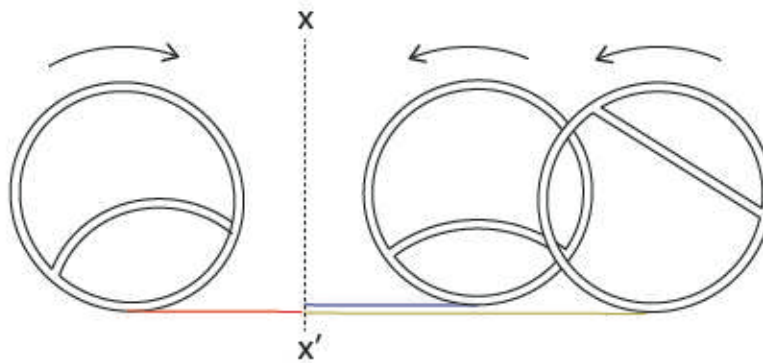

Q.61 Figure shows a clothes line attached to four independent pulleys P, Q, R & S. Which of the options represent the correct rotation of pulleys that would result in lowering the clothes line?

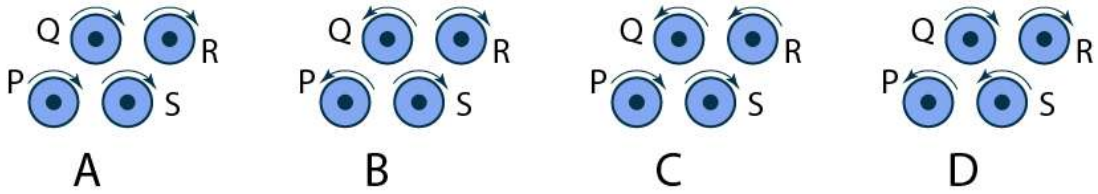
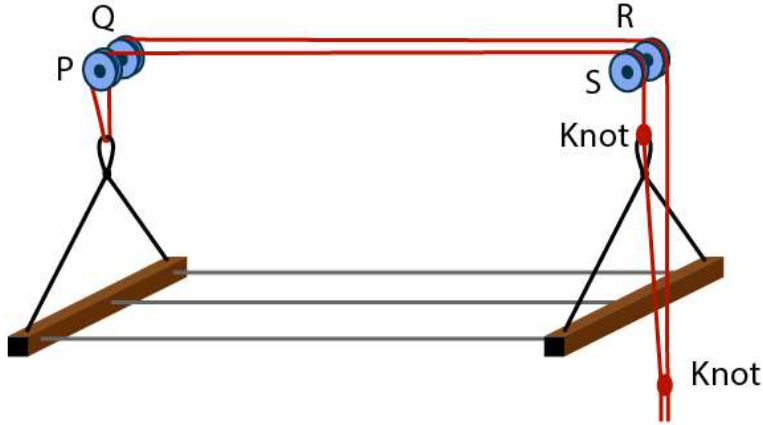

Q.62 Which of the options will replace the question mark?



A B C D

Q.63 Assume that the English alphabet was redesigned, and the new alphabet had alternating upper case and lower case letters. The alphabet starts with uppercase A, and

- 1) all upper case letters were rotated clockwise by 90 degrees
- 2) all lower case letters were rotated anti-clock wise by 90 degrees

Using the new alphabet, the word "HELP" would be written as:

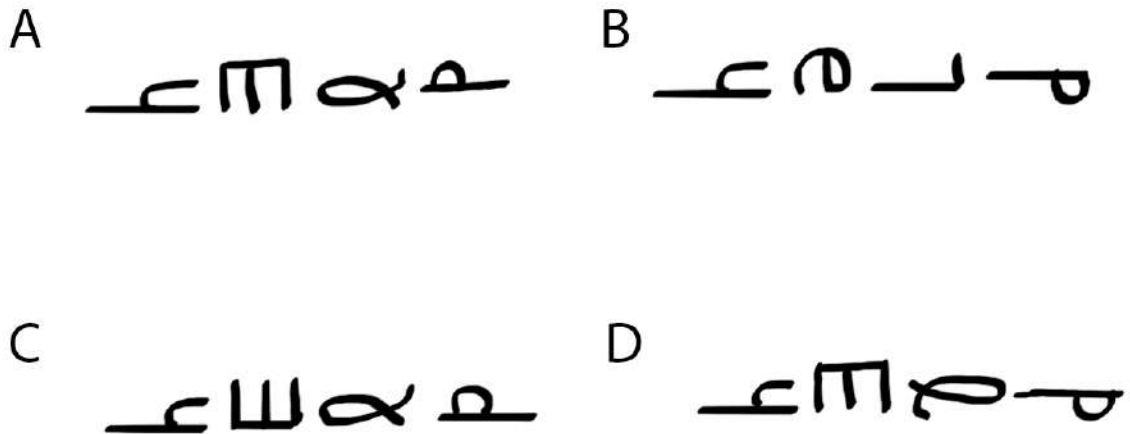

Q.64 If the given figure represents a cube in 3D, which of the options correctly represents its views from different sides?

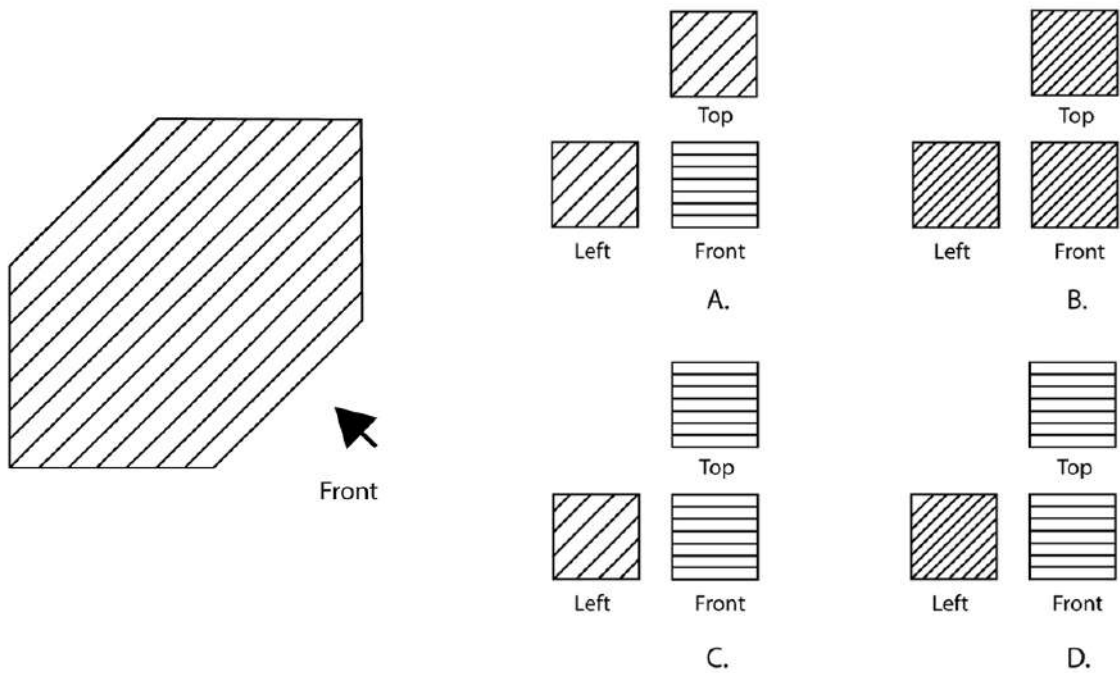

Q.65 A square is cut into 4 pieces. One of the pieces is shown on the left and the remaining three are in the options. Which of the options is NOT a part of the square?

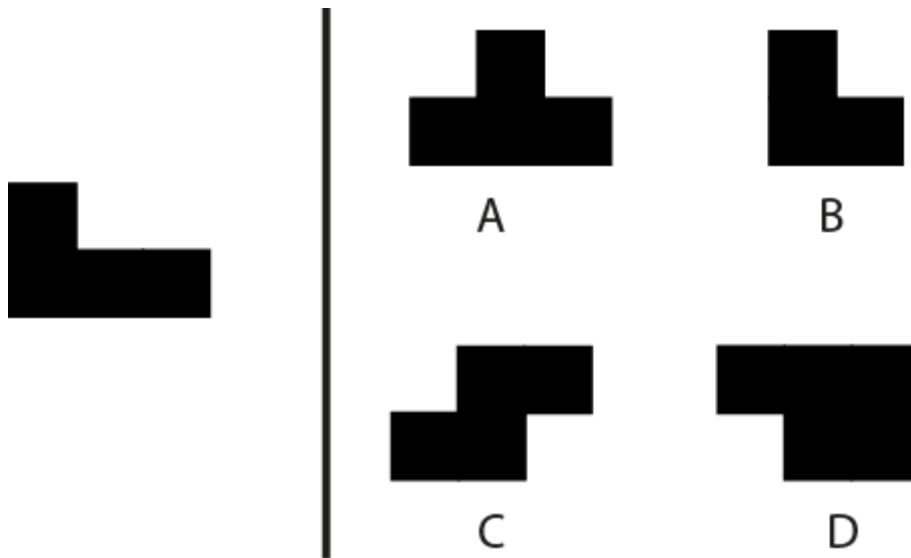

Q.66 In the figure given below which of the options will replace the question mark?

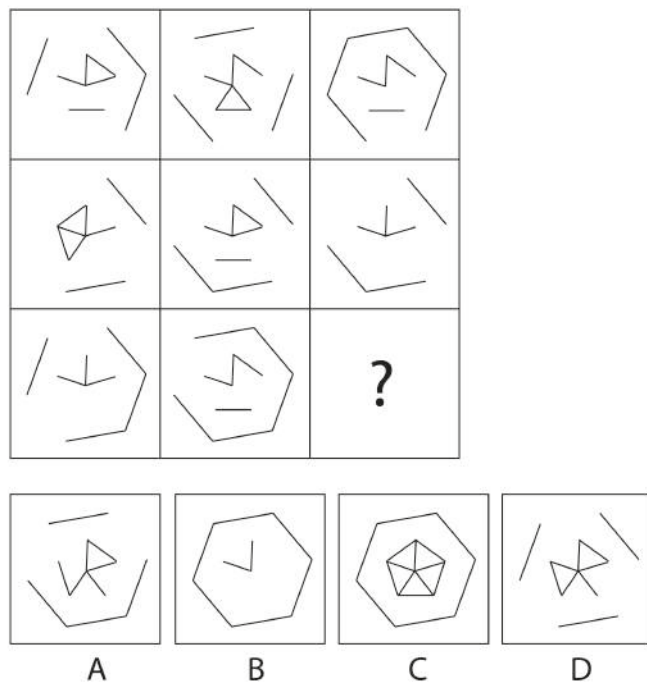

Q.67 Which of the options can be associated with all the objects?

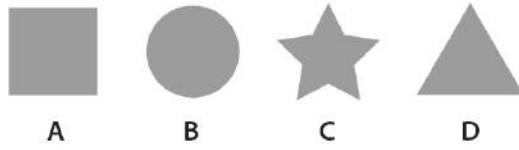

Q.68 Select the correct option.

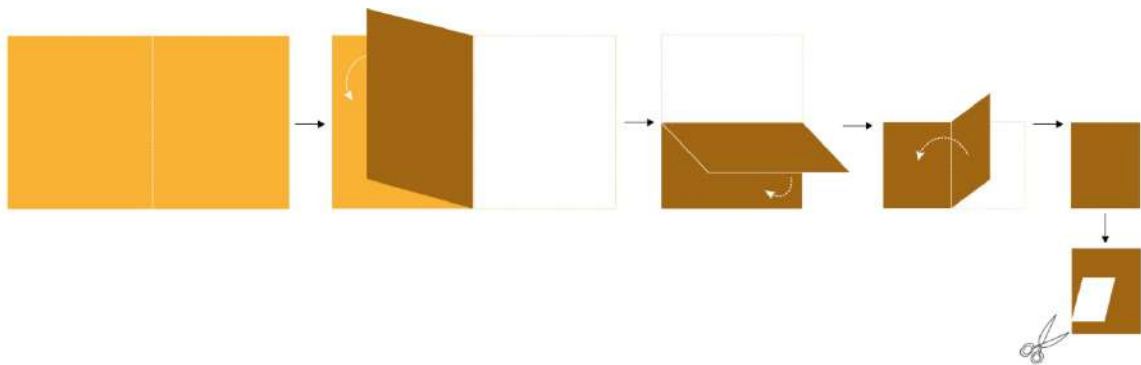

PART B

Mandatory question

Q.1 Sketching

(30 minutes – 60 marks)

Prof. Shastri was checking maths papers when she got a call from her husband. Mr. Shastri was upset that she forgot the diet lunch box that he had specially prepared for her. He was also annoyed that she left the dining table in a mess with all her papers and books piled up. He further accused her of cheating on her diet by eating canteen Pakodas and Aloo Parathas for lunch. Prof. Shastri tried to pacify him by saying that she had been working since morning as she needed to finish checking papers and writing her research proposal by 5 pm that evening and that she even had a headache from skipping lunch. Mr. Shastri was not convinced and reminded her that she hadn't even read the diet book he had sent and was probably using it as a paper weight in her office. He concluded that she wasn't serious about her health and proceeded to declare that he will not be cooking for her from then on. Prof. Shastri hung up the phone and in frustration ordered her fifth cup of tea from the canteen and her second plate of Pakodas.

From the above description, sketch Prof. Shastri's desk from her usual point of view.

Note:

- Make pencil sketches only
- Do not use colours
- Do not draw Prof. Shastri

Evaluation Criteria:

- Observation
- Imagination
- Selection & composition of objects
- Quality of line
- Presentation
- Attention to detail

UCEED 2019 Final Answer Key

The sequence of these Answer Keys corresponds to the sequence of questions in the Question Paper uploaded on the UCEED Website.

Section A: NAT		Section B: MSQ		Section C: MCQ			
Question	Answer	Question	Answer	Question	Answer	Question	Answer
Q01	3	Q21	C D	Q41	D	Q61	B
Q02	22	Q22	A B	Q42	A	Q62	A
Q03	315 OR -315	Q23	B C D	Q43	B	Q63	C
Q04	44	Q24	A B C D	Q44	B	Q64	B
Q05	18	Q25	C	Q45	A	Q65	B
Q06	18	Q26	B D	Q46	A	Q66	C
Q07	20	Q27	C OR C D	Q47	B	Q67	B
Q08	7	Q28	A C D	Q48	C	Q68	B
Q09	9	Q29	A B	Q49	C	Q69	B
Q10	57	Q30	A C	Q50	C	Q70	D
Q11	10	Q31	A C D	Q51	B	Q71	D
Q12	450	Q32	B D	Q52	D	Q72	B
Q13	399	Q33	A B D	Q53	B	Q73	C
Q14	96	Q34	B D	Q54	A	Q74	A
Q15	24	Q35	A C	Q55	A	Q75	C
Q16	1190	Q36	A C	Q56	C	Q76	A
Q17	22 OR 23	Q37	A B D	Q57	D	Q77	D
Q18	9	Q38	A C	Q58	C	Q78	B
Q19	112	Q39	B D	Q59	B	Q79	D
Q20	160	Q40	A B C D	Q60	A	Q80	D
						Q81	B
						Q82	B
						Q83	A
						Q84	C
						Q85	A

Undergraduate Common Entrance Examination for Design

UCEED 2019

Question Paper



Indian Institute of Technology Bombay

Paper Specific Instructions

1. The examination is of 3 hours duration. There are a total of **85 questions** carrying a total of 300 marks. The paper is divided into three sections, **A, B** and **C**. All sections are compulsory. Questions in each section are of different types.
2. **Section A (60 Marks)** contains a total of 20 **Numerical Answer Type (NAT)** questions. For each question, the answer is a real number that needs to be entered using the virtual keyboard on the monitor. No choices will be shown for these questions. There is **NO NEGATIVE** marking for this section. Each correct answer will be awarded 3 marks. Questions not attempted or answered incorrectly will be given zero mark. Questions from 1 to 20 belong to this section.
3. **Section B (60 Marks)** contains a total of 20 **Multiple Select Questions (MSQ)**. Each question may have **one or more than one correct choice(s)** out of the four given. A question is considered correctly answered if ALL the correct choices and NO wrong choices are selected for that question. There is NEGATIVE marking for this section. Each question answered correctly will receive 3 marks. Each question wrongly answered will receive -0.19 (minus zero point one nine) mark. There is NO PARTIAL marking for this section. Questions not attempted will be given zero mark. Questions from 21 to 40 belong to this section.
4. **Section C (180 Marks)** contains a total of 45 **Multiple Choice Questions (MCQ)**. Each question has four choices out of which ONLY ONE is the correct answer. There is NEGATIVE marking for this section. Each correct answer will be awarded 4 marks and each wrong answer will receive -1.32 (minus one point three two) mark. Questions not attempted will be given zero mark. Questions from 41 to 85 belong to this section.
5. Calculators, charts, graph-sheets, mathematical tables, mobile phone, smart watches and/or other electronic gadgets are **NOT** allowed in the examination hall.
6. Blank sheets of paper will be provided for rough work.
7. Marking Scheme for the paper is given in the table below.

Section	Number of questions	Marks for each correct answer	Marks for each wrong answer	Marks for each question not attempted	Total marks for the section
NAT	20	3	0	0	60
MSQ	20	3	-0.19	0	60
MCQ	45	4	-1.32	0	180
Total	85				300

Section A: Numerical Answer Type Questions

Section A (60 Marks) contains a total of 20 Numerical Answer Type (NAT) questions. For each question, the answer is a real number that needs to be entered using the virtual keyboard on the monitor. No choices will be shown for these questions. There is **NO NEGATIVE** marking for this section. Each correct answer will be awarded 3 marks. Questions not attempted or answered incorrectly will be given zero mark. Questions from 1 to 20 belong to this section.

Q.01 Shown below are sole designs of slippers, of which some are matched-pairs (one left foot and one right foot). Identify the total number of matched-pairs in the image.



Q.02 X1 is a 3D form generated from the shape X, using certain 3D operations. It has 11 surfaces in total. If the same operations are carried out on shape Y, how many surfaces would the resulting 3D form have?

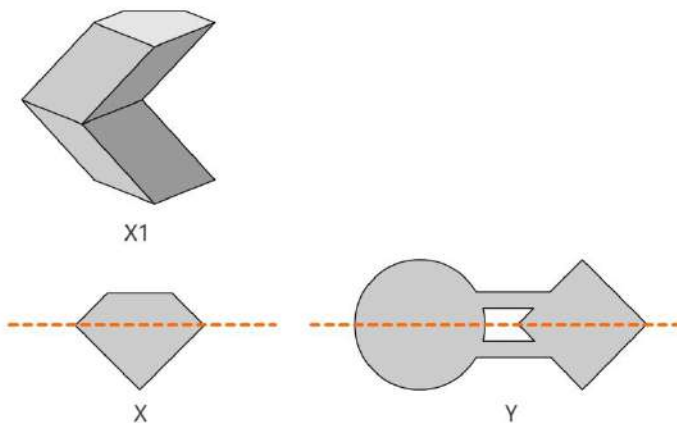

Q.03 Fifteen people from different places came together for a family reunion. Each one of them had two gifts each for every other person. When the gifts were exchanged they hugged each other. What is the difference between the number of hugs and the number of gifts exchanged?

Q.04 A tetrahedral puzzle is made of smaller tetrahedrons. Shown below is one side of the puzzle and a small tetrahedron. Assuming that all the faces of the puzzle are the same, how many small tetrahedrons are there on the faces of the larger tetrahedron?

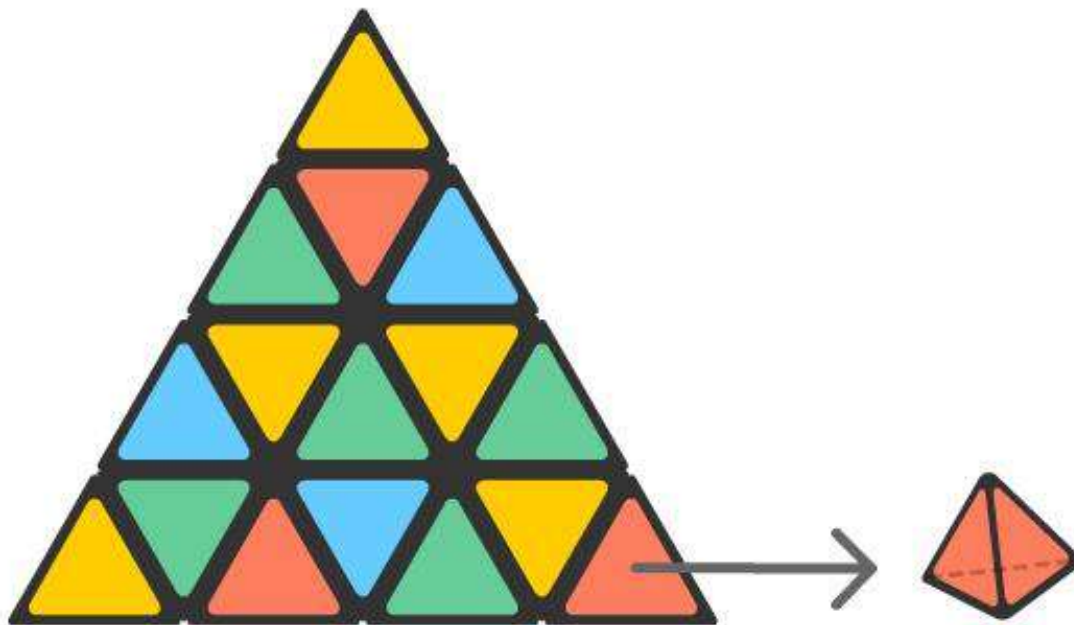

Q.05 The picture shows decimal numbers encoded in colors in some other number system. Encodings of six numbers have been given in the picture on the left. Picture on the right shows a multiplication that we need to perform. What decimal number represents the result of this multiplication?

0		21	
3		23	
10		24	

×

Q.06 A cube has its six faces *numbered* 1 to 6. A school boy tosses up the cube twice and notes down the two numbers appearing on top in these two tosses. He multiplies these two numbers and notes down the multiplication result. How many unique multiplication results can he possibly get through this tossing game?

Q.07 Three transparent glass pieces with different engravings are shown below. They are to be overlapped, one on top of the other, with the red corner exactly matching each other. What is the total number of triangles in the resultant figure?

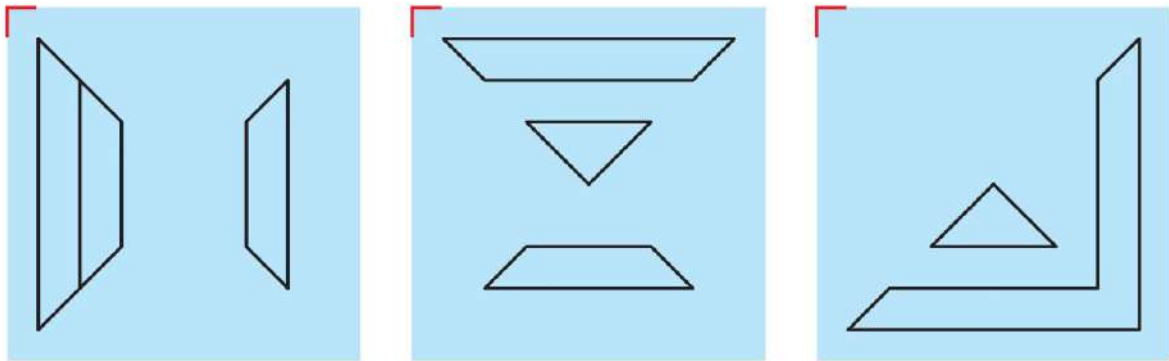

Q.08 A diagram of three blocks A, B and C and their direction of movement is shown below. The blocks move continuously in units and change directions after hitting the side walls. From the given position, if block A moves at a speed of 2 units per second, and block B and block C move at a speed of 1 unit per second, what is the least time (in seconds) that is required for all blocks to align exactly one below the other?

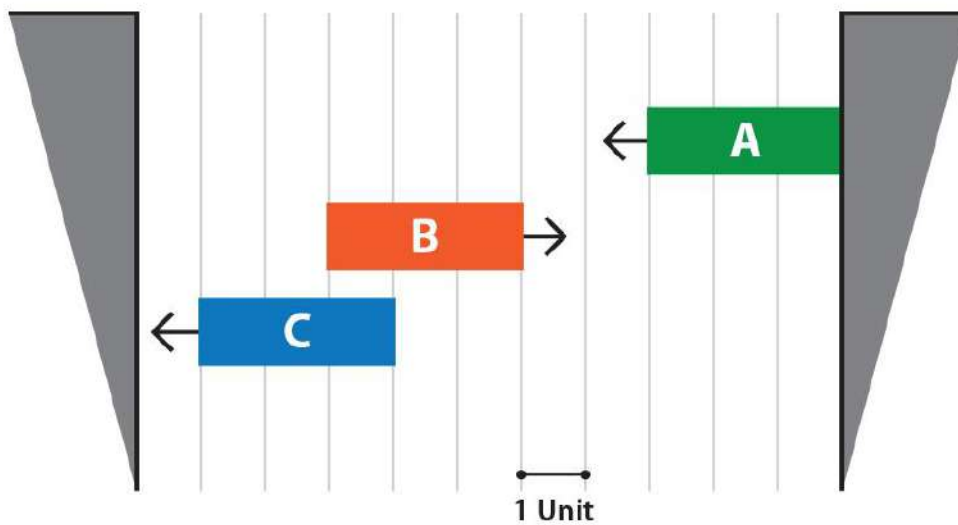

Q.09 A UNION of two solids, a pentagonal prism and a hexagonal prism is shown below. The side view (on the right) depicts how the solids intersect. Visualise the new solid formed by their INTERSECTION (the part common to both of them). How many surfaces will the new solid have?

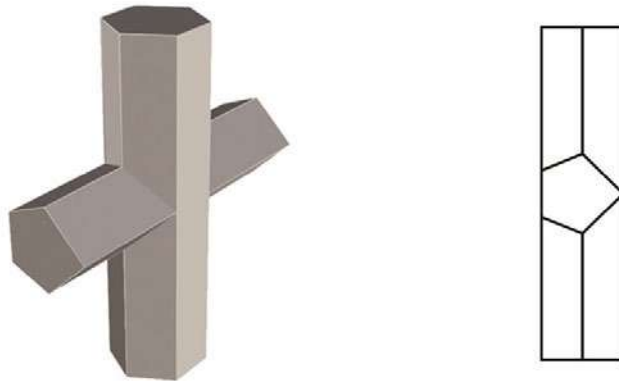

Q.10 A solid object made of cubes is shown below. This object is symmetric about all three axes, and does not contain cavities (no hollow spaces). How many cubes does the solid contain?

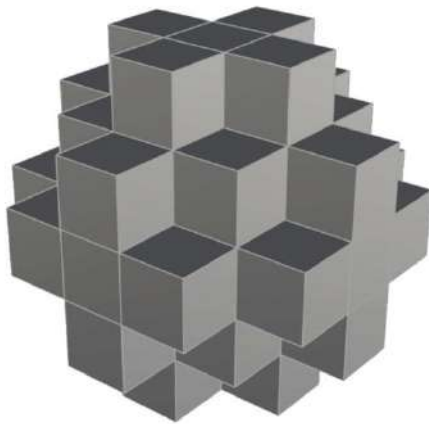

Q.11 A solid is drilled using a cylindrical drill in a direction, as shown below. How many surfaces will the solid have after the drilling is complete?

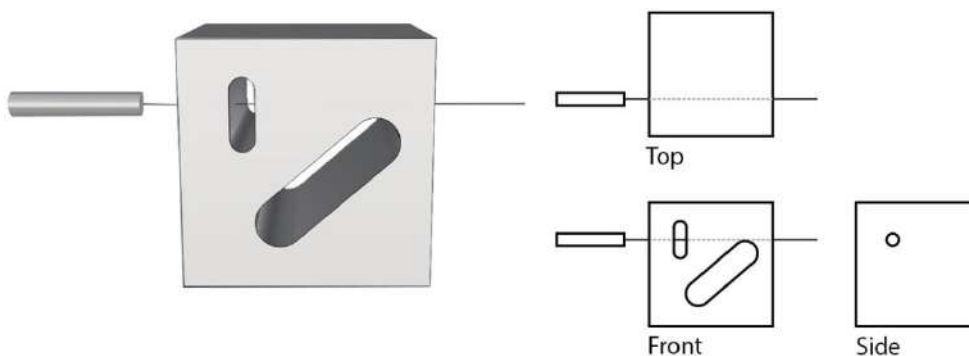

Q.12 The figure below shows a hinged structure made up of 12 sticks. The structure can be elongated and compressed by changing the angle ABR. As shown in the figure, the distance between B and Q is $150\sqrt{6}$ (one hundred and fifty times root six) units when the angle ABR is 90 degrees. What will this distance be when the angle ABR is changed to 60 degrees?

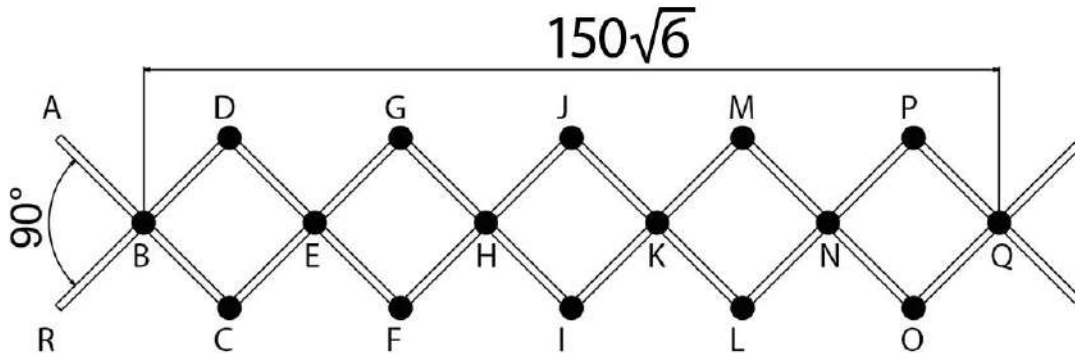

Q.13 In a new form of decimal system, the numbers 0 to 9 are represented by a new set of symbols. For example, the equation $1 + 4 = 5$ is represented as equation (i). If in the solution to equation (iv) one digit appears twice, what number will replace the question mark?

- (i) $1 + 4 = 5$
(ii) $7 + 8 = 9$
(iii) $10 - 1 = 9$
(iv) $898 + 999 = ?$

Q.14 What is the area (in cm^2) of the black portion, if the square is of length 16 cm?

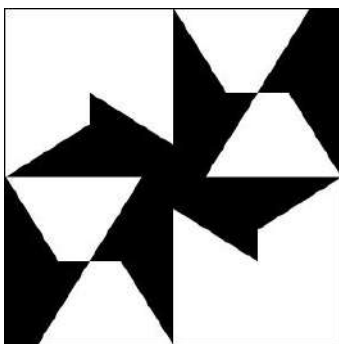

Q.15 The figure shows two concentric equilateral triangles with a circle within, such that the circle touches all the edges of the triangle. If the radius of the circle is $\sqrt{3}$ (square root of three), what is the total length of the star shaped outer border formed by the two intersecting triangles?

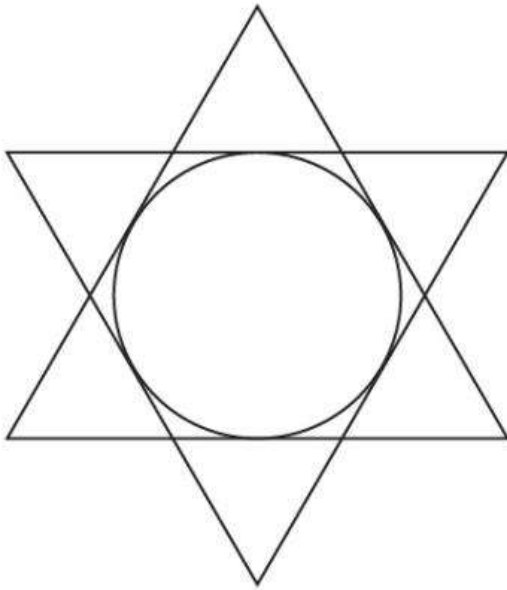

Q.16 Except for one number, all the four-digit numbers given below are written using a single font. Identify the number that does not use the same font as the other numbers.

3697 5574 1767 6367 5985
 7514 3683 3270
 1676 8431 3584 2018
 1450 1070 4208 1190
 3601 1847 8504 8075
 6063 2044
 1502 7070 4338 3015
 6049 1342 8075 4852

Q.17 Two perspective views of the same solid object are shown below. Count the total number of surfaces in the object. Assume hidden surfaces to be flat.

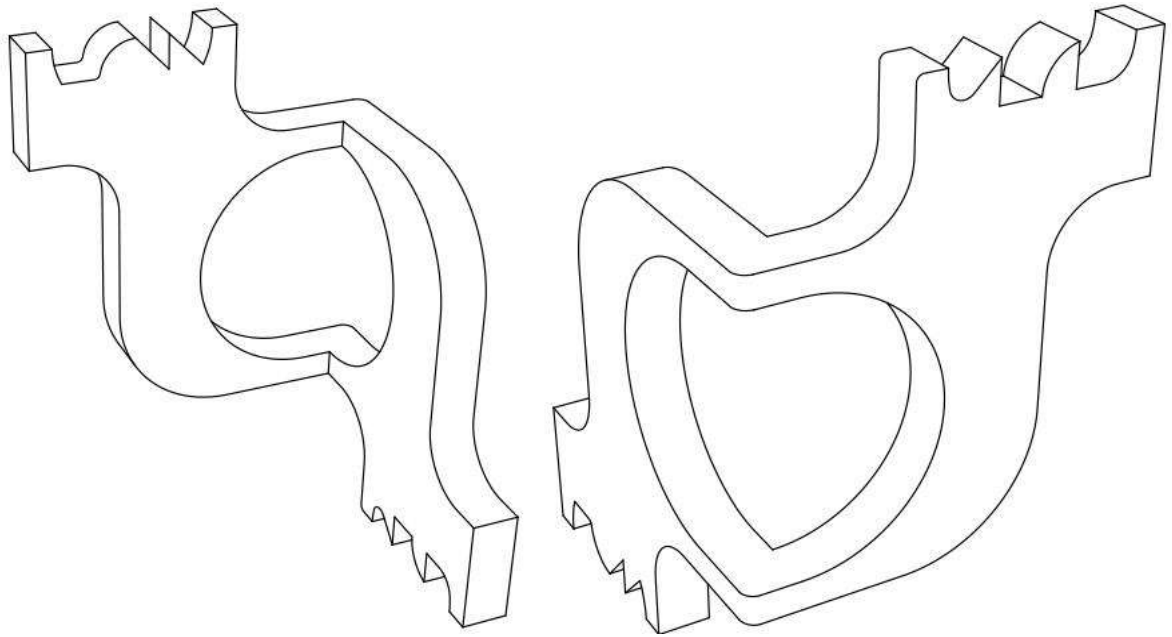

Q.18 The image given below is made out of separate pieces. What is the least number of pieces that need to be moved and/or rotated and/or flipped for achieving symmetry about the central vertical axis?

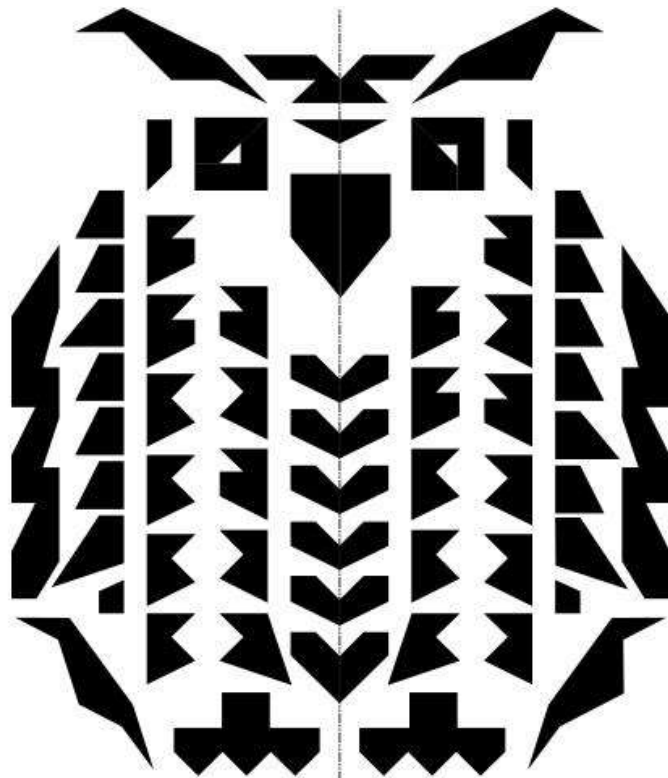

Q.19 A logo was designed by creating a pattern of orange petals using four semicircles. These petals were then inscribed in a green circular shape with an inner diameter of $14\sqrt{2}$ (fourteen times square root of two) units, what is the area of the orange part in the logo? (Assume $\pi = 22/7$)



Q.20 Shyam runs a dairy. In his cattle herd, each white cow gives 12 litres of milk, each brown cow gives 7 litres of milk and each yellow cow gives 10 litres of milk every day. He has drawn a sketch of his herd which is shown below. Using this sketch, calculate the amount of milk (in litres) produced by his dairy per day?

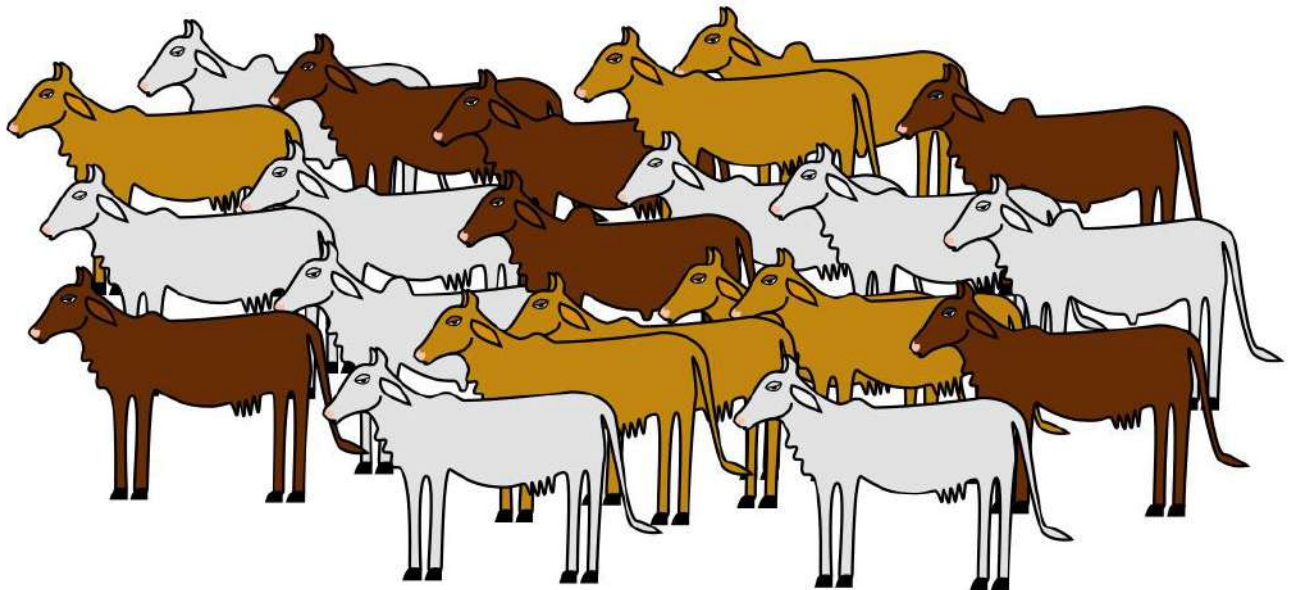

Section B: Multiple Select Questions

Section B (60 Marks) contains a total of 20 **Multiple Select Questions (MSQ)**. Each question may have **one or more than one correct choice(s)** out of the four given. A question is considered correctly answered if **ALL** the correct choices and **NO** wrong choices are selected for that question. There is **NEGATIVE** marking for this section. Each question answered correctly will receive 3 marks. Each question wrongly answered will receive -0.19 (minus zero point one nine) mark. There is **NO PARTIAL** marking for this section. Questions not attempted will be given zero mark. Questions from 21 to 40 belong to this section.

Q.21 Tile X was used to create a seamless pattern when arranged as shown below. Which tile(s) from the options will create a seamless pattern (pattern without gaps)?

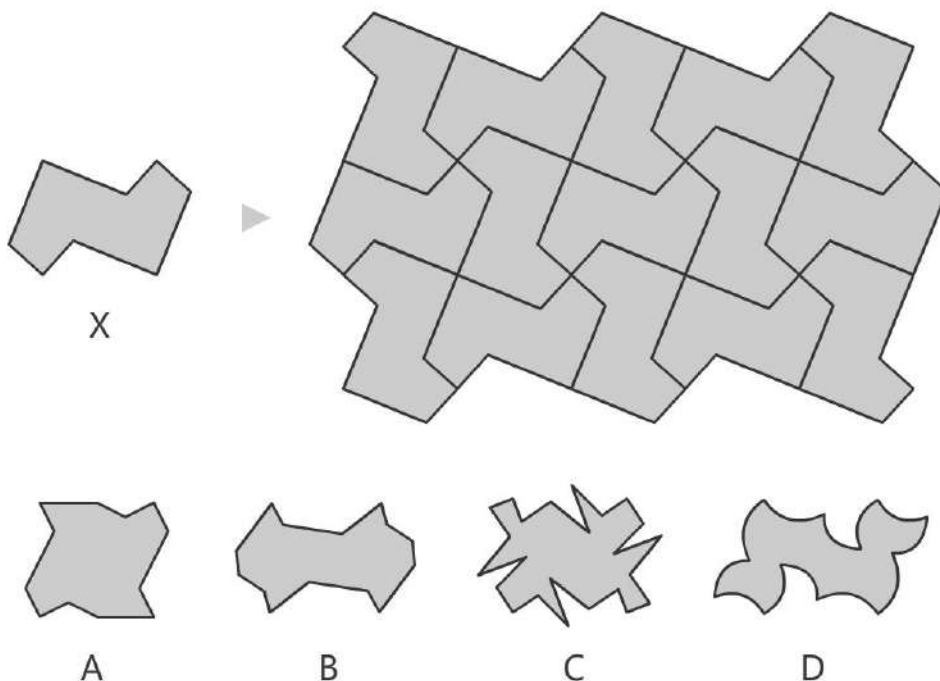

Q.22 Which of the following statements related to Indian musicians is/are TRUE?

- A. Ustad Allah Rakha and Ustad Zakir Hussain are known for playing the Tabla
- B. Pandit Nikhil Banerjee and Ustad Vilayat Khan are known for playing the Sitar
- C. Ustad Ali Akbar Khan, Ustad Amjad Ali Khan and Dr. L. Subramaniam are known for playing the Violin
- D. Pandit Ravi Shankar and Pt. Hariprasad Chaurasia are known for playing the Shehanai

Q.23 Which of the options on the right can be formed by folding the profile shown on the left?

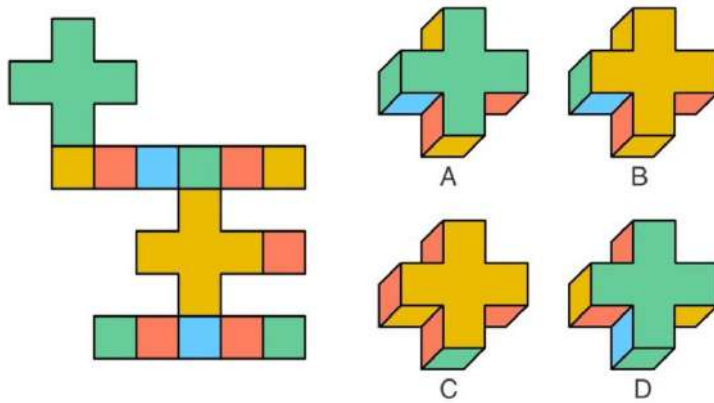

Q.24 In a 3D structure made of cubes of equal size, an L shaped hole is made by removing a few cubes, as shown on the left. Which of the 3D structures in the options on the right would successfully pass through the L shaped hole, given that they are also made of cubes of same size?

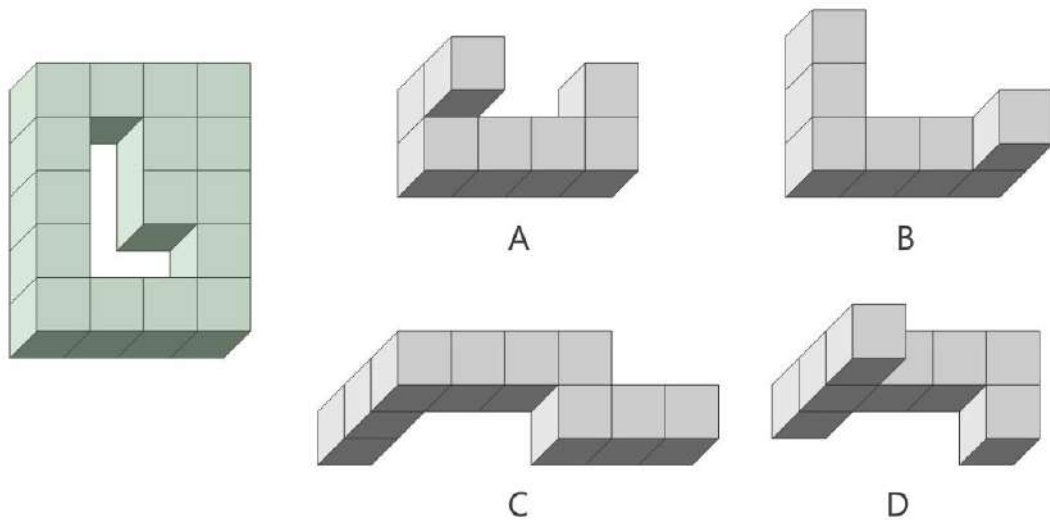

Q.25 The figure given below shows six bar charts corresponding to the volume of agricultural produce from farms of various farmers. The actual quantities are also shown in the figure. Red bars indicate tomatoes, green bars indicate leafy vegetables, and blue bars indicate berries. Assume that they have seen each other's bar charts. Who can correctly make at least one of the following statements?

(i) Everyone who produced any one item more than what I produced, she also produced every other item more. (ii) Everyone who produced one item less than what I produced, she also produced at least one other item less.

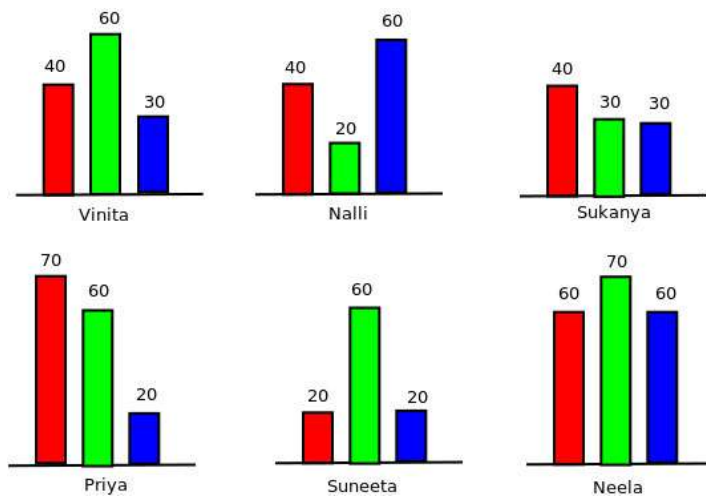

- A. Vinita
- B. Priya
- C. Neela
- D. Suneeta

Q.26 The figure shows four road networks. Which of these four road networks can be traversed by a traveller, such that the following challenge can be satisfied: "The traveller must cover all the roads in the network. She is allowed to visit a city more than once, but she is not allowed to travel on any road more than once. Also, the traveller must come back to the city where she starts."

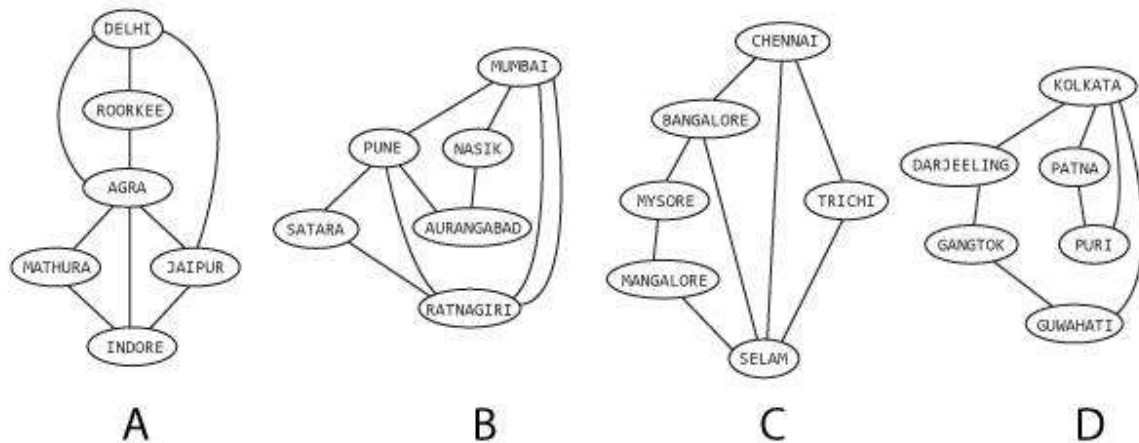

Q.27 The grid of squares shown in the figure is to be tiled (covered with tiles) with the tiles shown in the options. The covering tiles must not overlap and should not have gaps around them. Only four squares in the middle are not to be tiled. Once a tile is chosen, other tiles must be of that type only. Tiles can be flipped and rotated if required. Which of the tiles can be used to tile the given grid?

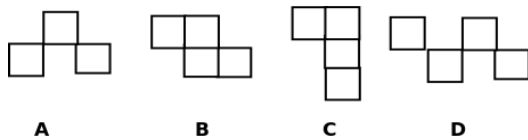
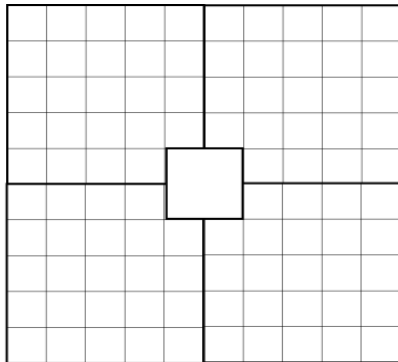

Q.28 Suresh, Biju and Tina bring one gift each. When they meet, they swap their gifts in such a way that no one gets back what they had brought with them. The gifts are, a book, a pen, and a ball.

Suresh says: I gave my gift to the one who gave away the ball.

Biju says: I received my gift from the one who gave gift to the one who gave away the ball.

Tina says: I got what I always wanted.

Biju says: But Tina, you had to give away your pen.

Which of these statements is/are TRUE?

- A. Tina gets the Ball
- B. Tina gets the Book
- C. Suresh gets the pen
- D. Biju gets the Book

Q.29 If the geometric solid blocks shown below, are cut along a single flat plane, which of these can have the cross section of a regular hexagon (all sides equal)? Assume, all blocks are extruded from polygons with sides of equal length.

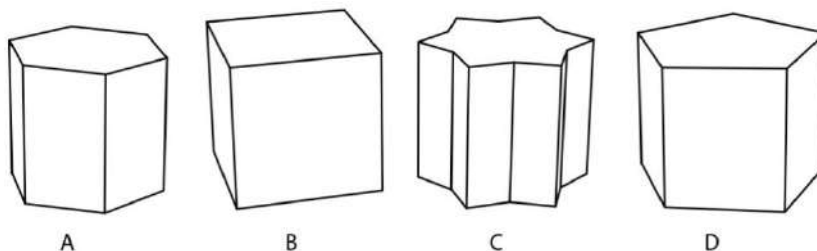

Q.30 The following patterns are made on a wall by using ceramic tiles. Which of the given patterns is/are made from a single type of tile?

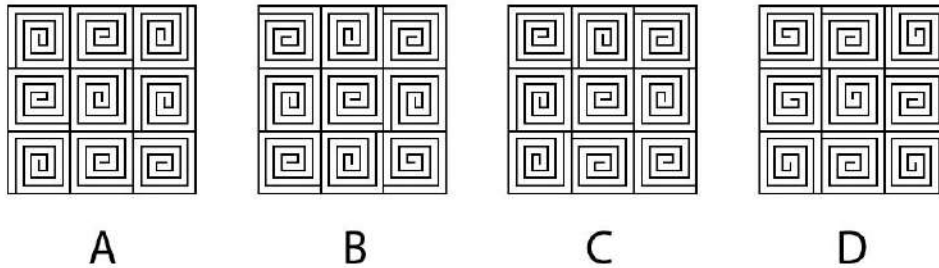

Q.31 Which of the following statements about the areas of Indian states is/are TRUE?

- A. Arunachal Pradesh is larger than Kerala
- B. Punjab is larger than Assam
- C. Chhattisgarh is larger than Jharkhand
- D. West Bengal is larger than Uttarakhand

Q.32 Image P shows a portion of a larger photograph. Some operations have been done on that photograph using an image manipulation software. Image Q shows a portion of the resulting photograph. Identify the option(s) that specifies/specify the correct operations.



- A. Rotate clockwise by 90 degrees, flip horizontally, then rotate clockwise by 90 degrees
- B. Rotate clockwise by 180 degrees, then flip horizontally
- C. Rotate clockwise by 180 degrees, then flip vertically
- D. Rotate clockwise by 90 degrees, flip vertically, then rotate clockwise by 90 degrees

Q.33 Which of the following birds is/are native to (found in) India?



A



B



C



D

Q.34 The word given below uses a particular font. Which option(s) belongs/belong to the same font?

Soulful

2

A

3

B

6

C

5

D

Q.35 A set of two frames with square openings when perfectly overlapped with each other allow light though it in certain patterns. Shown below are four sets of such frames. These frames are either hinged (A and B) or pivoted (C and D) to each other. Assuming that the red frames are fixed and the blue frames are allowed to move, which option(s) will allow light to pass through as in the pattern shown on the left?

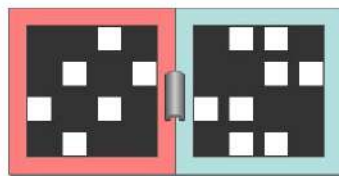

A

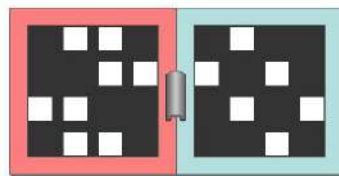

B

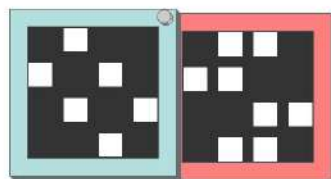

C

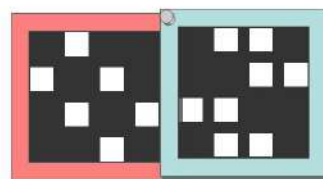

D

Q.36 Refer to the tools below and read the statements. Based on what you can see, which of the following options is/are correct?



- A. All tools have atleast one common working principle
- B. All of them can be used for cutting fabric
- C. Only one has spring back element, at least one has provision to crack nuts
- D. Three of them have a provision to crack nuts

Q.37 Multiple pages of a book are often printed on a single sheet. The sheet is later folded and cut appropriately to get the pages in a correct sequence and orientation. Mistakes happened while printing this particular 16 page booklet. The sheet was printed with pages numbered and oriented as shown on the left. The sheet was folded and cut in the sequence as shown on the right. Given this, which of the options is/are TRUE about the final booklet?

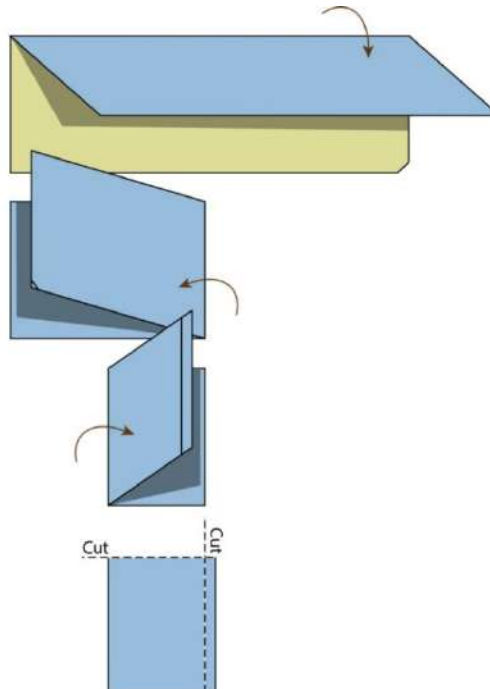
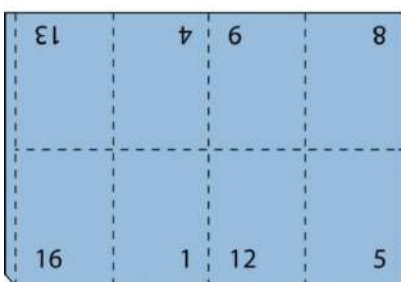
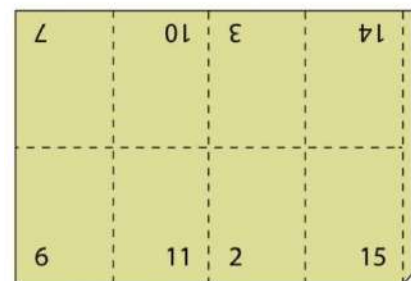

- A. Page 13 appears before page 10
- B. Page 11 is the last odd-numbered page
- C. Page 4 is the first even-numbered page
- D. All pages appear in the correct orientation

Q.38 A bag contains 20 socks, of which 10 are white and 10 are black. If the socks are drawn without replacement, which of the options is/are TRUE?

- A. If 1 sock is drawn at random, the chance that it is white is 50%
- B. If 2 socks are drawn at random, the chance that both of them are the same colour is 50%
- C. If 3 socks are drawn at random, the chance that at least two of them are the same colour is higher than if only 2 socks are drawn at random
- D. If 4 socks are drawn at random, the chance that at least two of them will be the same colour is higher than if only 3 socks are drawn at random

Q.39 In the figure below, a person is putting small packets of potatoes in one of the bins A, B or C. The packets are placed on a table, and the bins A, B and C are placed on tables which are lower in height as compared to table on which the packets rest. Which of the following statements is/are TRUE?

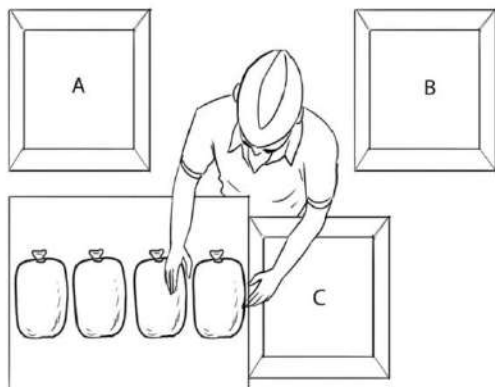

- A. Lifting the bag from the table and placing it in bin B will be less effortful compared to lifting and placing it in bin C
- B. Lifting the bag from the table and placing it in bin A will be more effortful compared to sliding it in bin C
- C. Lifting the bag from the table and placing it in bin B will be less effortful than sliding it to bin C
- D. Sliding the bag from the table to bin C will be less effortful than lifting it and placing it in bin C

Q.40 In a town, there are four kinds of persons: Mizrabs, Frets, Dictions and Scripts. People of any given kind play exactly two musical instruments. An instrument is played exactly by people of two kinds. Some Mizrabs play Tabla. Some Frets play Sitar. The kind that plays Harmonium does not play Sarod. The kind that plays Tabla does not play Sitar. Mizrabs and Dictions do not play the same instrument. Frets and Scripts do not play the same instrument. Dictions do not play Harmonium.

Which of the following is/are TRUE?

- A. Frets do not play Tabla
- B. Scripts play Tabla
- C. Mizrabs play Harmonium
- D. Dictions play Sitar

Section C: Multiple Choice Questions

Section C (180 Marks) contains a total of 45 Multiple Choice Questions (MCQ). Each question has four choices out of which ONLY ONE is the correct answer. There is NEGATIVE marking for this section. Each correct answer will be awarded 4 marks and each wrong answer will receive -1.32 (minus one point three two) mark. Questions not attempted will be given zero mark. Questions from 41 to 85 belong to this section.

Q.41

ඡත්තීස්ගඪ් = Chhattisgarh

කේරල = Kerala

පන්ජාබය = Punjab

ගුජරාතය = Gujarat

Maharashtra = ?

A. තමිල්නාඩුව

B. රාජස්ථාන්

C. ක්‍රිෂ්ණා

D. මහාරාෂ්ට්‍ර

Q.42 The word given below uses a particular font. Which option belongs to the same font?

ප්‍රසිද්ධ

ව ව ව ව

A

B

C

D

Q.43 Which option will replace the question mark?

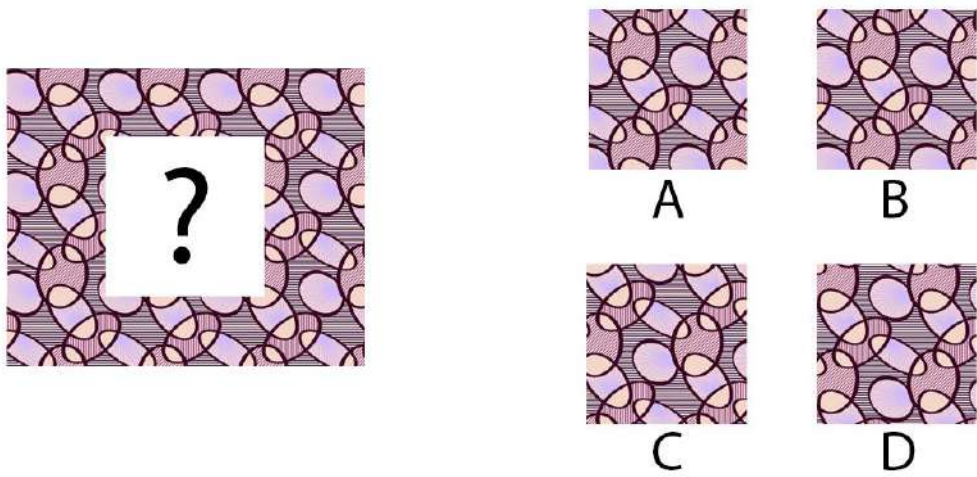

Q.44 An envelope made of a single piece of paper is taken, and a few cuts are made on it. The envelope and the cuts are shown below. Identify the resulting figure when the envelope is unfolded?

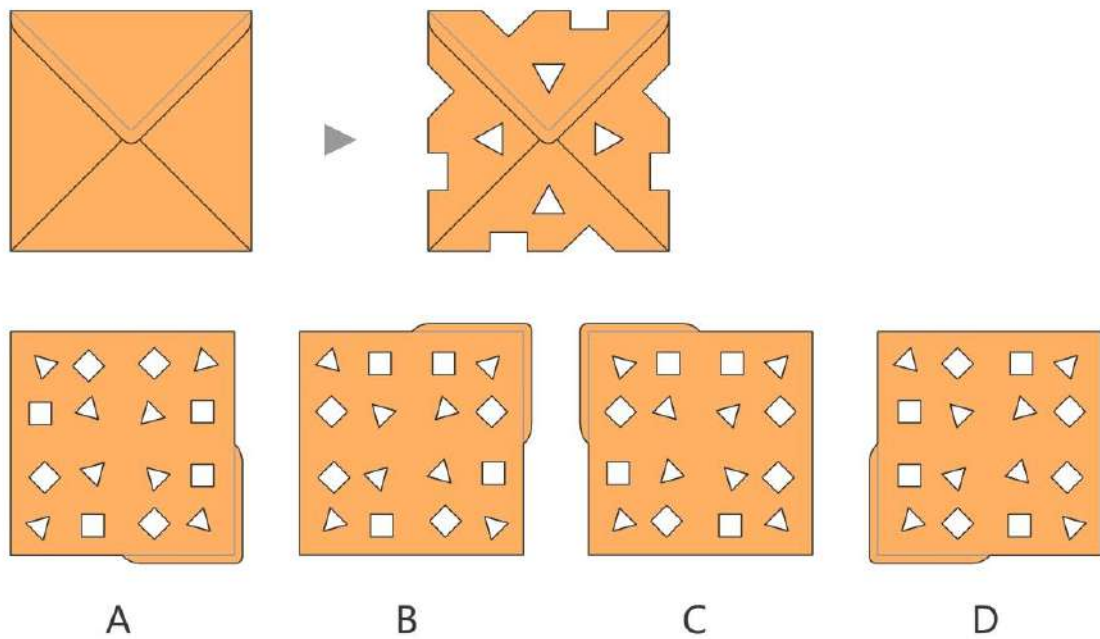

Q.45 Shown in the four figures A, B, C, and D on the right, are broken lines drawn on a transparent sheet. Each figure is folded over along the dotted lines as shown. Identify the correct option that will generate the motif shown on the left.

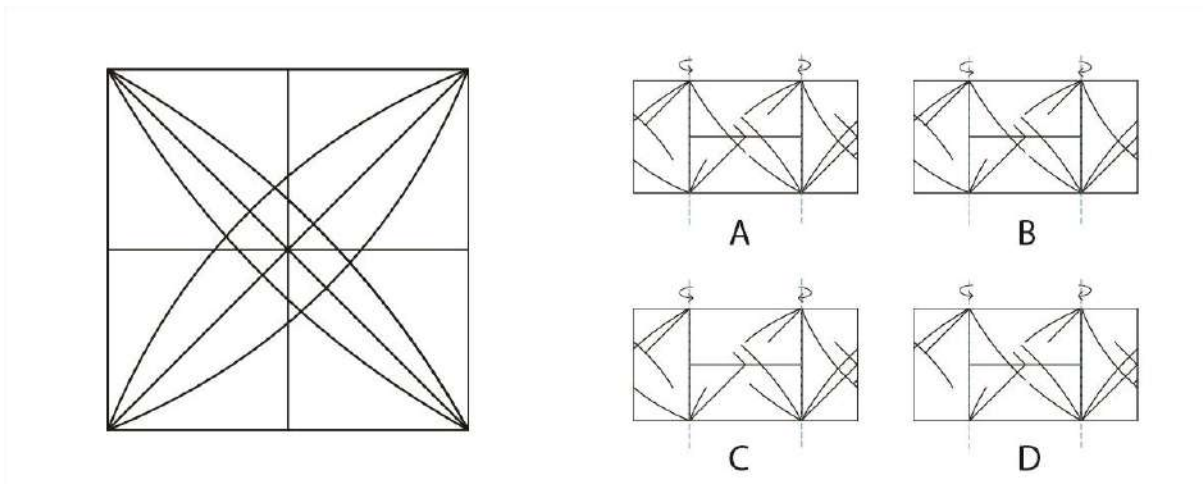

Q.46 A light source is attached to a rod fixed in the centre of the ceiling of a square room. This source rotates 360 degrees with the rod as its axis. This source projects a red beam of light onto the four walls of the room. This setup is shown in the isometric view and the side view in the figure below. Identify the correct path of the beam of light on the four walls of the room.

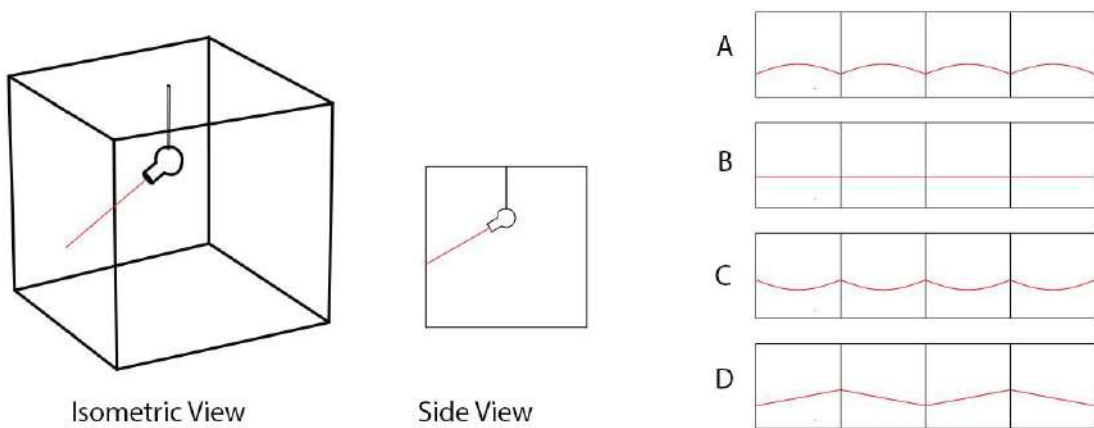

Q.47 The figure below shows the top view, the front view, and the side view of a three-dimensional solid object. What is the minimum number of surfaces that a solid with these views, can have? Assume that there are no hidden lines.

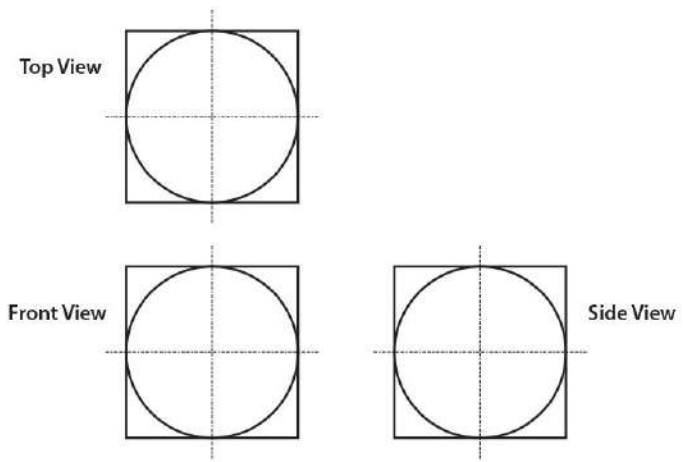

- A. 12
- B. 14
- C. 16
- D. 30

Q.48 Sheetal is running. Which option denotes the most natural pose?

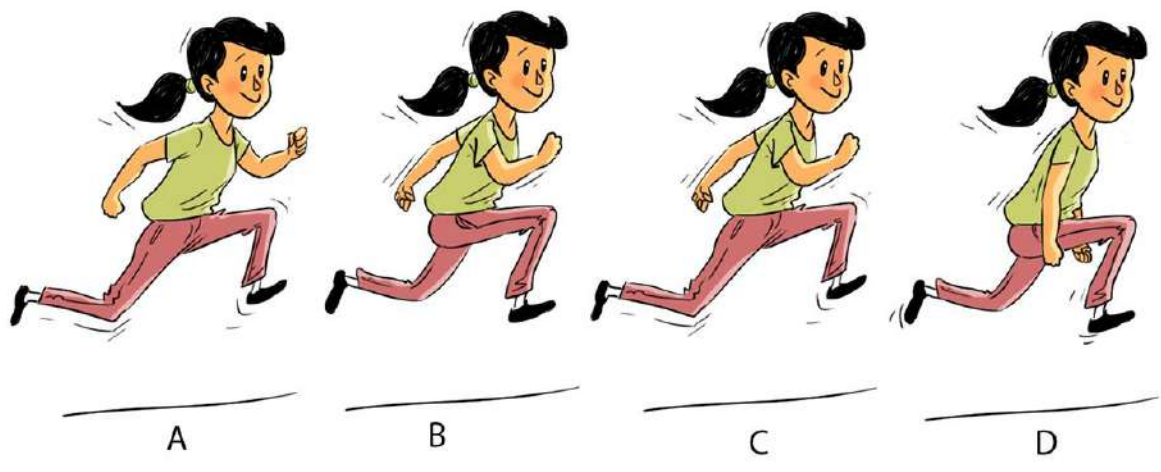

Q.49 Identify the correct profile of the cricketer that corresponds to the given front pose.

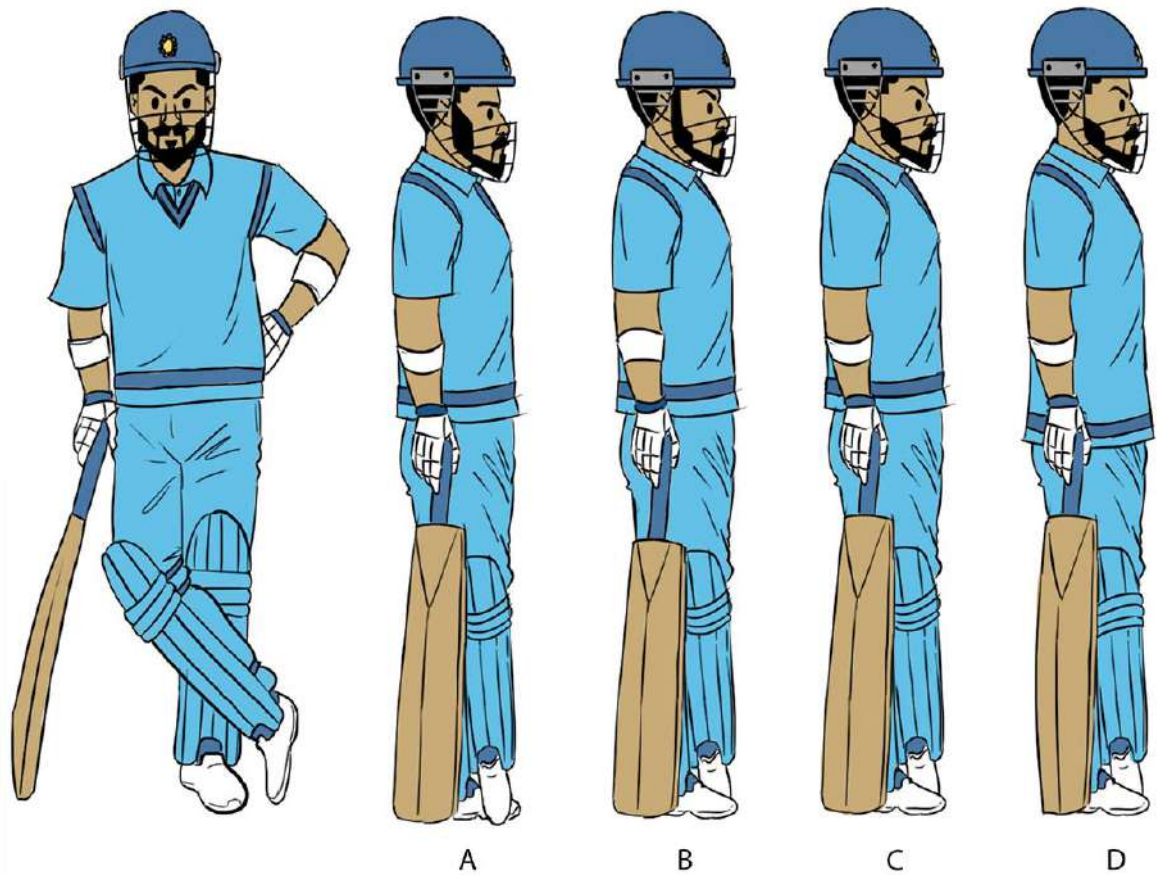

Q.50 Seema on the left, is looking at a mirror. Which option shows her reflection correctly?

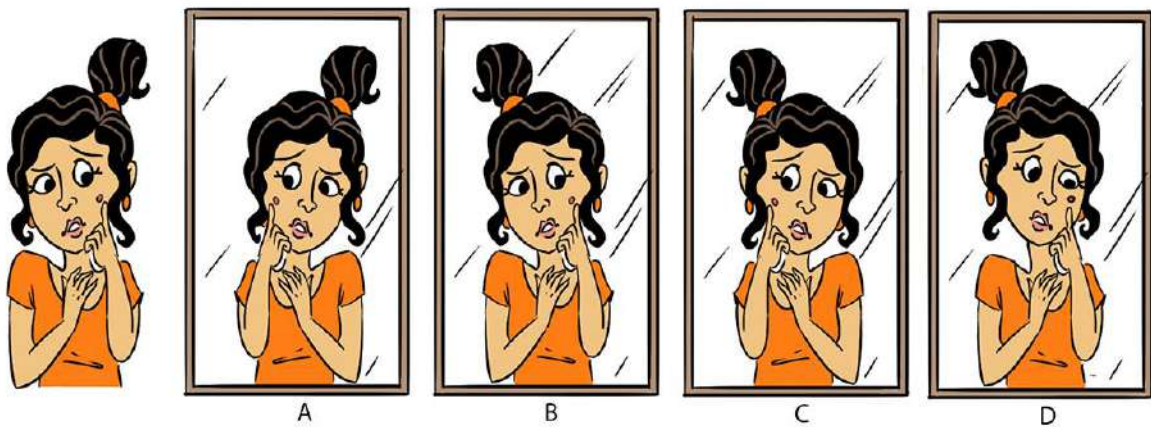

Q.51 Kavita is holding a lit torch below her face as she narrates a ghost story to her friends in a dark room. Which option shows the lighting correctly?

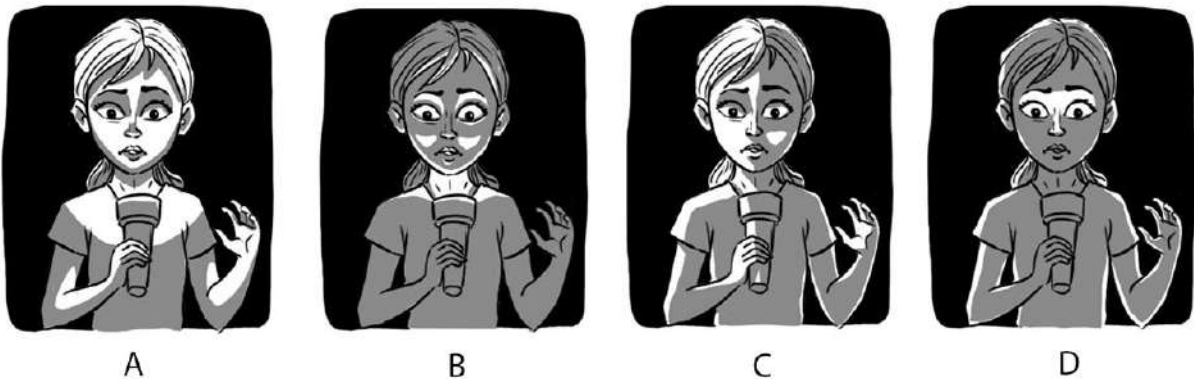

Q.52 Which option correctly represents the top view for the given perspective view?

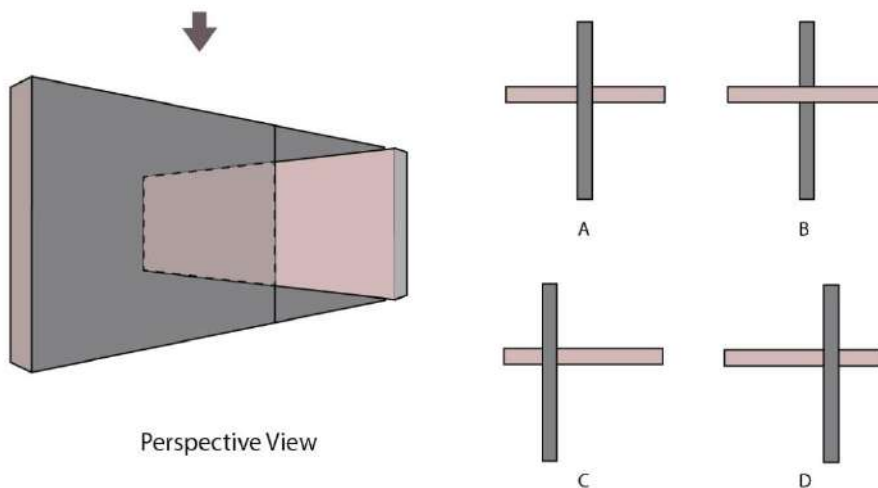

Q.53 A milkman is returning from his trip on his bicycle. He has two empty containers of 5 litres and 3 litres hanging on one side of the bicycle, and a full 8 litres milk container on the other side. He was not able to ride the bicycle properly. So he stopped and decided to distribute the milk, so that the load becomes balanced on the both sides of the bicycle. Unfortunately he has forgotten his measuring cup on his last stop.

How many minimum turns will it take for him to be able to distribute the milk into two equal halves to balance the load? Ignore the weight and other material properties of the containers and the bicycle.

- A. 6
- B. 7
- C. 8
- D. 9

Q.54 Four students P, Q, R and S are shown a box which contains a few white balls, and a few red balls. Their teacher asks each of them individually to make a statement. The teacher knows that exactly one of them is a liar and others are not. From the statements that they make, the teacher is able to find out who the liar is. Given below are the statements made by the students. Who is the liar?

P says: There are equal number of red balls and white balls.

Q says: P is a liar and there are 3 red balls and 2 white balls.

R says: Q is not a liar and there are some red balls and some white balls in the box.

S says: R is not a liar.

- A. P is the liar
- B. Q is the liar
- C. R is the liar
- D. S is the liar

Q.55 Shown below is an image with straight lines, in which, a tilted-square has been cut out. From the given options identify the missing cut out of the square that completes the original image.

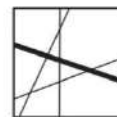
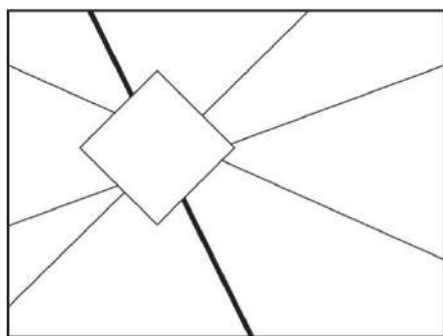

A



B

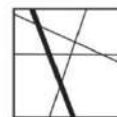

C



D

Q.56 A T-shirt with folding marks and the folding sequence is shown on the left. The folding is done backwards and perfectly along the lines. After completing all the folds, the T-shirt is then turned around. Identify the correct folded T-shirt from the options on the right.

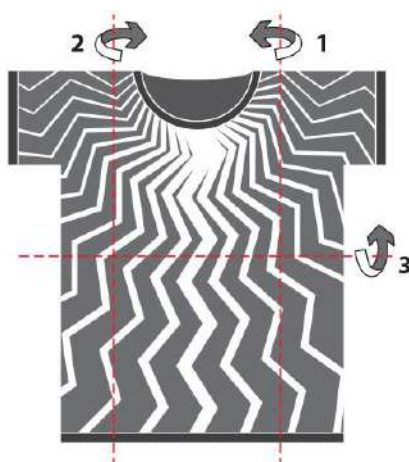

A



B



C



D

Q.57 A paper strip is rolled and then punched by a triangular punch, as shown below. After unrolling the paper strip, what would be the pattern of holes on the paper?

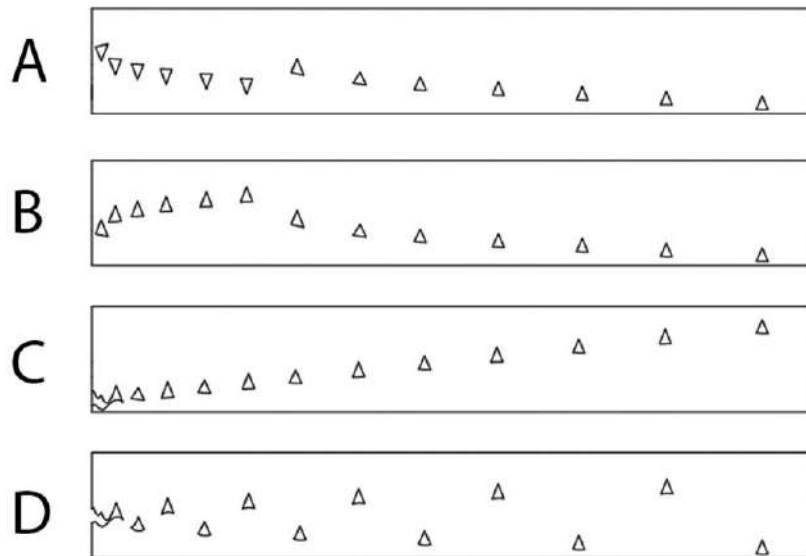
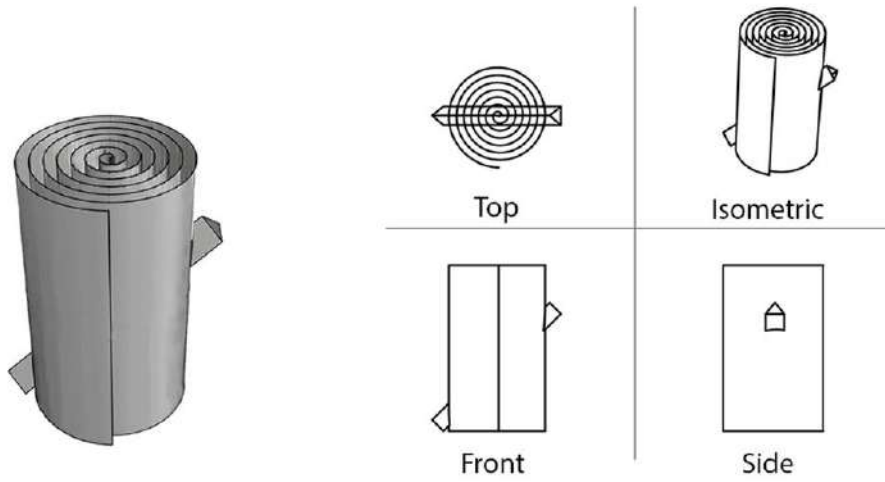

Q.58 Identify the option that will replace the question mark.

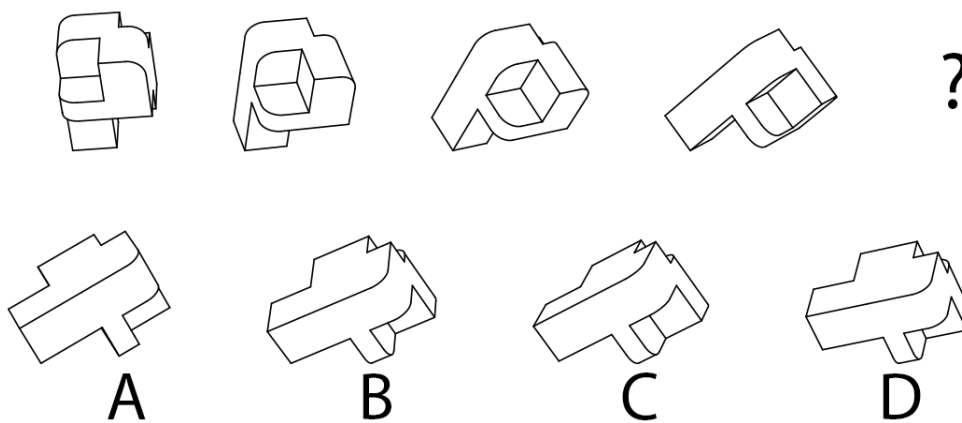

Q.59 How should the two solids be joined in order to form a tetrahedron?

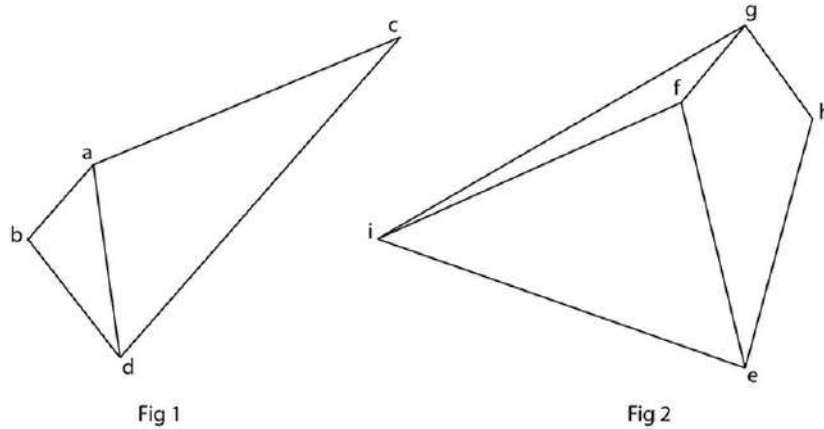

- A. ci, ag, be
- B. af, bg, ci
- C. ae, ci, bf
- D. ci, ae, dh

Q.60 Perspective view of an object is shown below. The object is rotated 180 degrees around y-axis (when viewed from a point on the positive y-axis towards the origin) and then similarly rotated 180 degrees around z-axis. Which of the following perspective view options will be the result of the rotations? Assume positive x and y axes point in the direction of the viewer.

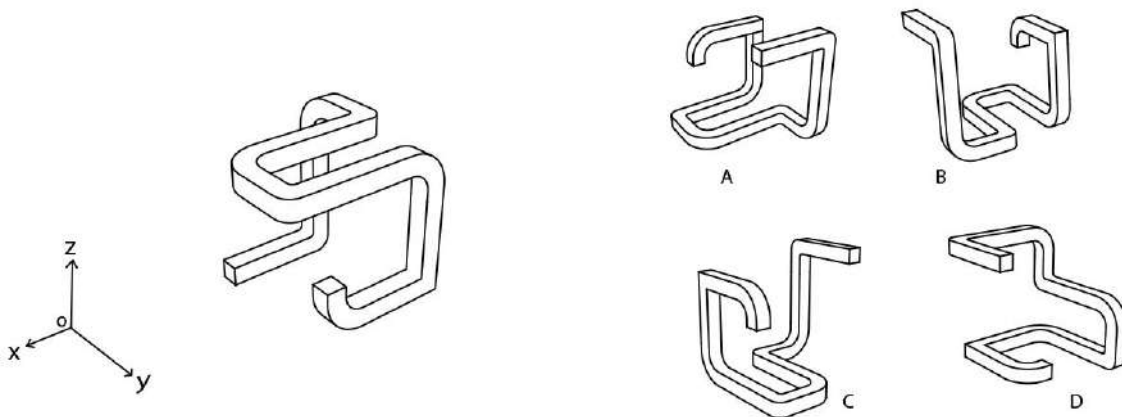

Q.61 On a glass entrance door of a building, there is an arrow sign pointing towards the newly shifted office space on the first floor. The sign is printed on a paper and pasted on the outside of the door using two tapes, one at the top-middle, and other at the bottom-middle. Due to the frequent use of the door, the top tape is peeled off, and the paper falls with the bottom tape holding it. After falling, from inside the building one can see the arrow sign pointing towards the Southwest direction. If that is the case, in which direction was the arrow sign originally pointing to (as seen from outside)?

- A. Southeast
- B. Northeast
- C. Northwest
- D. North

Q.62 A cube and a truncated cone are shown below. The cube has dimensions $10 \times 10 \times 10$ units. The truncated cone has a base diameter of 12 units, height of 11 units and top diameter of 6 units. Imagine these two solids are intersecting while positioned coaxially on the same base. Further imagine the cube vanishes completely along with the intersected portion of the truncated cone. What remains?

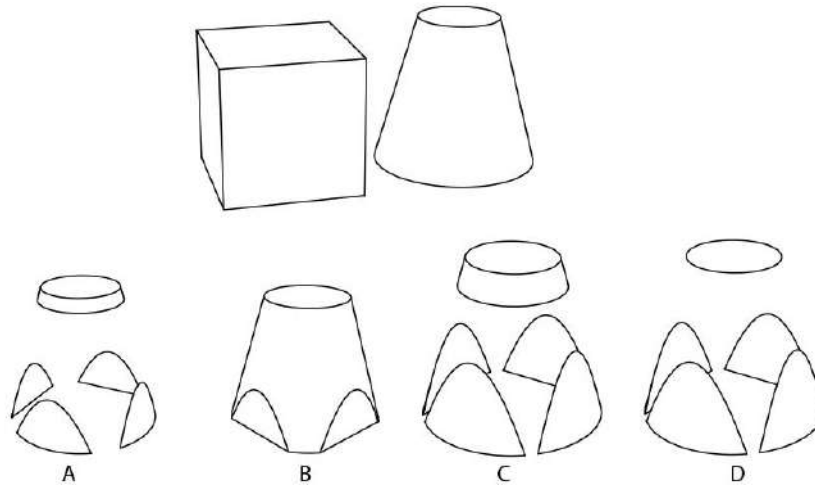

Q.63 Afreen is a teacher. She decides to give biscuits to her students Javed, Jai, Joshua and Jaspreet. She has biscuits of four different sizes, all of which have the same perimeter and thickness. The proportions of the biscuits are shown below. She asks Javed, Jai, Joshua and Jaspreet, in that order, to pick biscuits in descending (largest to smallest) order of volume. Which biscuits should Jai and Jaspreet pick up respectively?

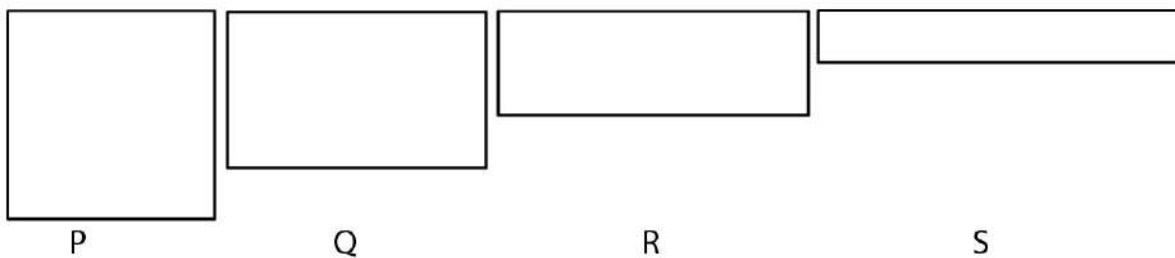

- A. Q and R
- B. P and S
- C. Q and S
- D. P and R

Q.64 A crocodile at point P sees four meatballs at A, B, C and D across the river. The crocodile moves with the same speed on ground as well as in water. If the speed of river is half the speed of crocodile, which meatball can it catch in the shortest time?

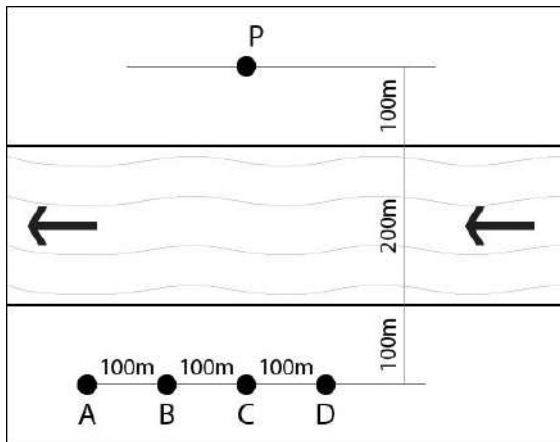

Q.65 Which number will replace the question mark?

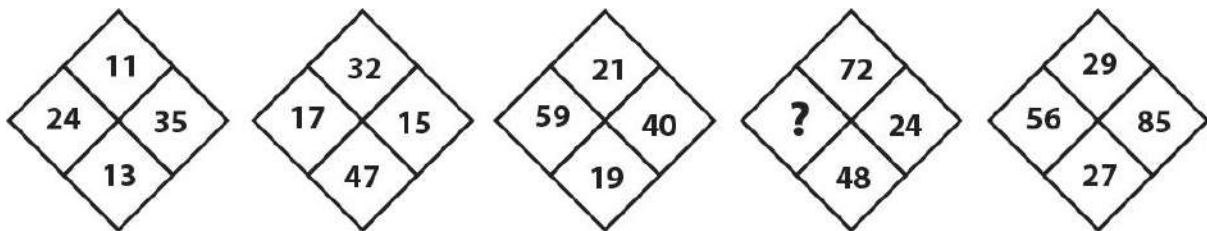

- A. 21
- B. 24
- C. 28
- D. 30

Q.66 Which black shape from the options will match the white shape in the figure, using simple rotation.

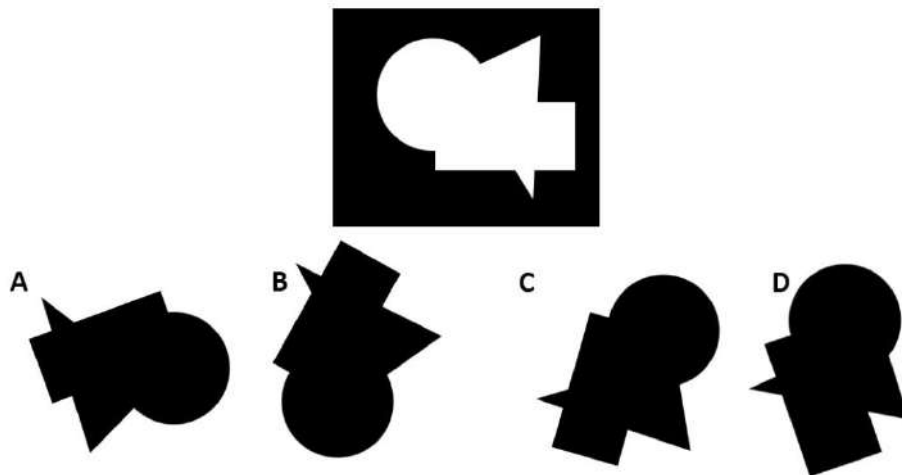

Q.67 The figure below shows a 3×3 cube with 4 colours. The same coloured shapes are detached and shown separately for reference. Identify the shape of the red block from the given options.

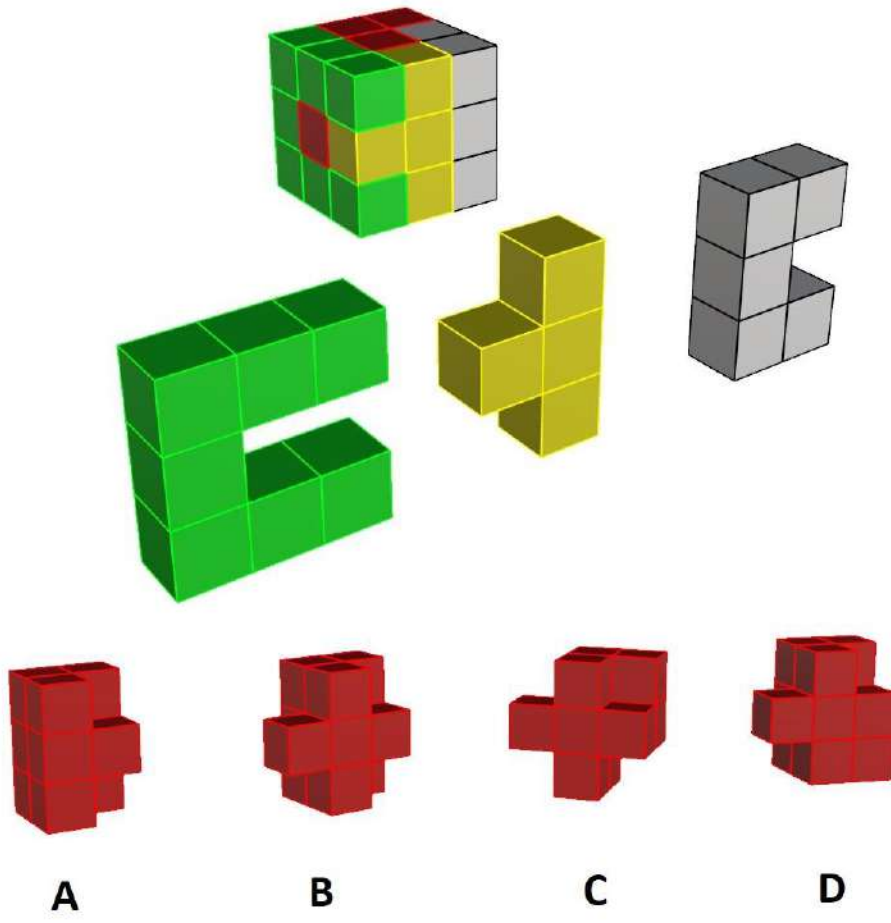

Q.68 Which option will replace the question mark?

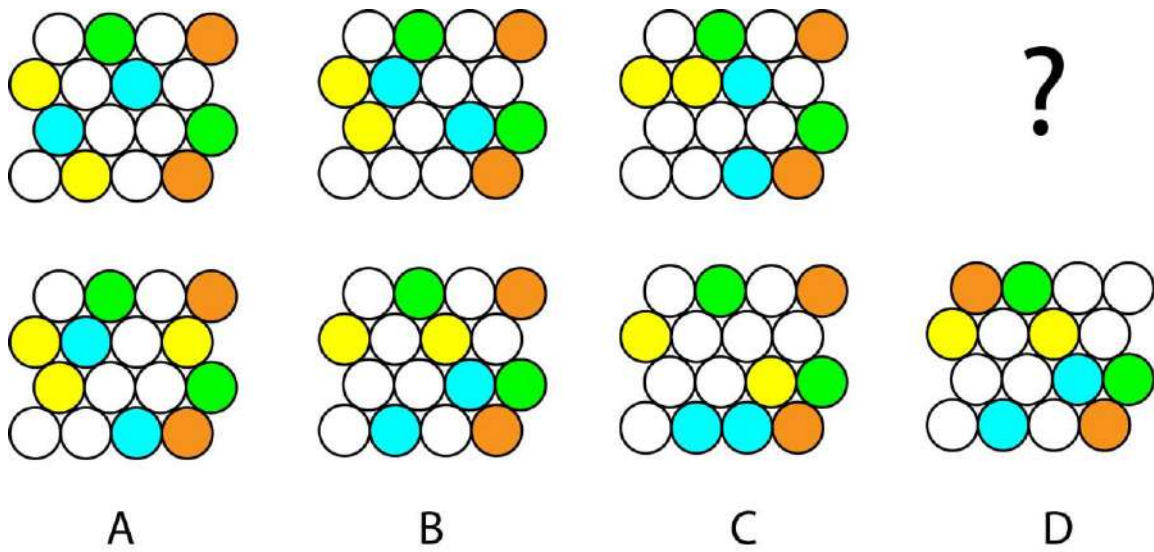

Q.69 Jaya, Sushama, Rama, Dilip, Sudhir and Arun are doctors working in a hospital specialising in gynaecology, neurosurgery, paediatrics, orthopaedics, anaesthesia and intensive care, not necessarily in that order. What is Rama's specialisation if the following conditions are to be met:

- Jaya, Arun and Sushama work together.
- Neurosurgeons always need the help of orthopaedic surgeons in the operation theatre.
- Orthopaedic surgeries cannot happen on the same days that gynaecological surgeries happen.
- Gynaecologists need paediatricians on standby during their operating hours.
- Though Sudhir and Dilip work together, neither has ever met Sushma in the hospital.
- All specialisations except intensive care need to work with Arun, the anaesthetist.
- Doctors don't work together other than as mentioned above.

- Neurosurgery
- Intensive care
- Orthopaedics
- Paediatrics

Q.70 Shown below on the left is a Ferris wheel which is not in motion. A photographer has clicked a photograph of the Ferris wheel while it was rotating at its maximum speed in an anti-clockwise direction. Which of the options below is the image that he has captured?

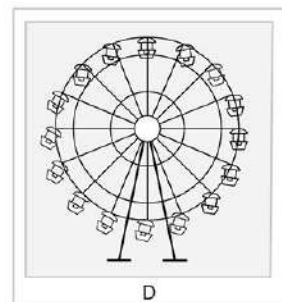
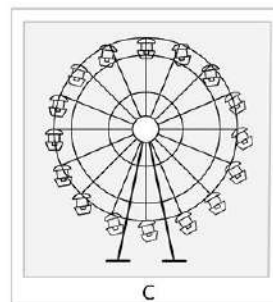
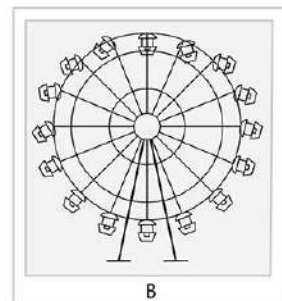
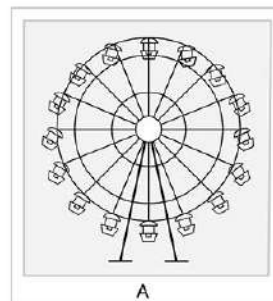
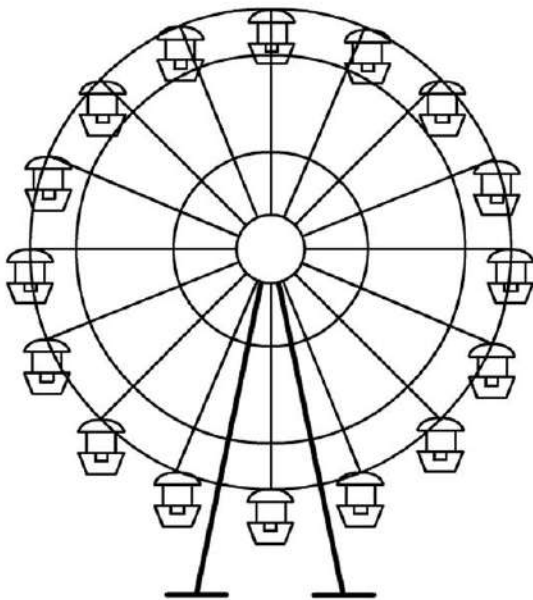

Q.71 Which option will replace the question mark?

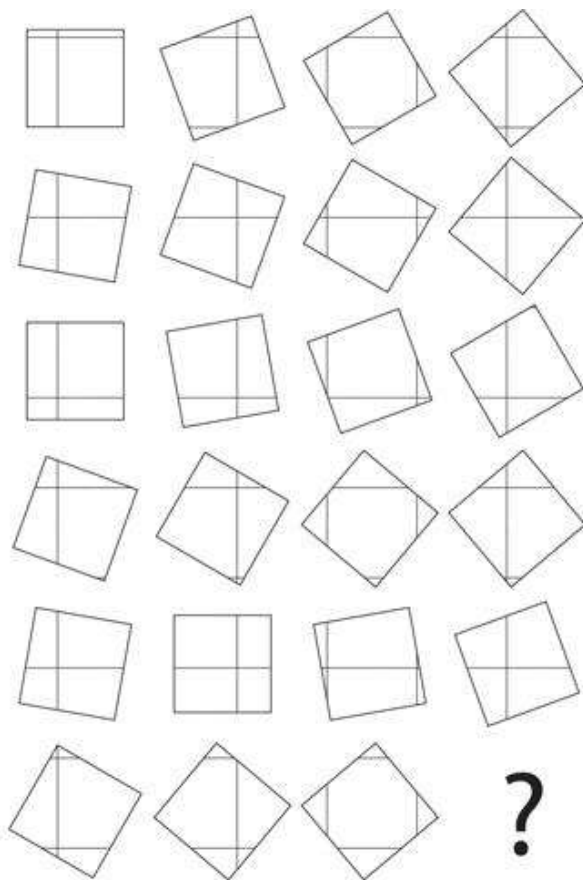

- A.
- B.
- C.
- D.

Q.72 Identify the correct order of rotation.

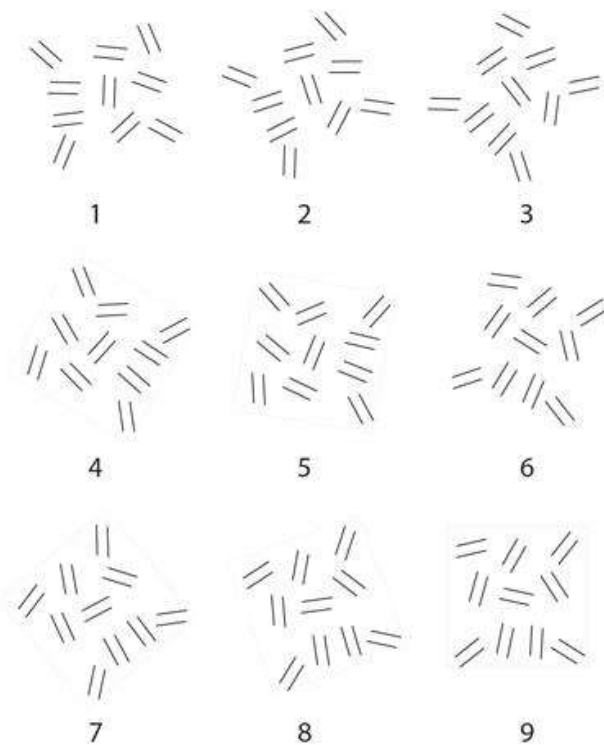

- A. 789654123
- B. 123698745
- C. 147852369
- D. 963258741

Q.73 The following images are iconic art forms/products of certain countries. Identify the correct set of countries they all can be predominantly attributed to. The individual countries in each set are in a random sequence.



- A. India, Turkey, Mongolia, Russia
- B. Mongolia, Burma, Afghanistan, India
- C. India, Russia, Japan, Turkey
- D. Pakistan, Japan, India, Mongolia

Q.74 Refer the following images of a metal artefact made using traditional manual tools, skills and processes. Identify the correct set of operations required to make it.



- A. Forging, Bending, Punching, Twisting
- B. Casting, Bending, Punching, Twisting
- C. Twisting, Drilling, Punching, Bending
- D. Bending, Casting, Forging, Punching

Q.75 Refer to the chairs shown below. Which of the following options is TRUE?



- A. P is most stable in terms of centre of gravity and R is made of least number of visible parts
- B. S is made of least number of visible parts and Q is most stable in terms of centre of gravity
- C. P is most stable in terms of centre of gravity and S is made of least number of visible parts
- D. R is ergonomically comfortable and Q is most stable in terms of centre of gravity

Q.76 Refer to the following image of a wooden product and read the statements below.

1. It has provision for cracking nuts, and it has a good grip
2. It has a good grip, and it has provision for opening cans as well as cracking nuts
3. It has provision for a grinding nuts, and its making involves drilling, twisting, and casting
4. Its making involves drilling, turning, and twisting

Which of the following options is correct?



- A. 1 is true, 2 and 3 are false
- B. 2 is true, 3 and 4 are false
- C. 3 is true, rest are false
- D. 4 is true, 1 and 3 are false

Q.77 Shown is a quadrant that is mirrored first on x-axis and then on y-axis. Identify the correct complete figure from the given options.

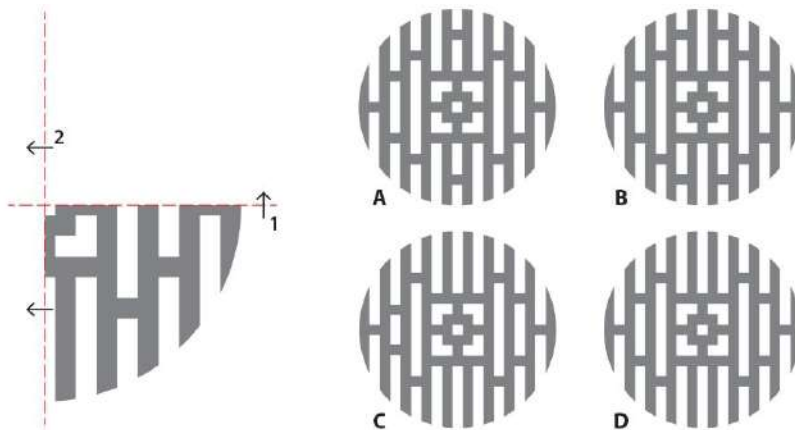

Q.78 Thamarai's father has made a roti for her lunch. She folds the roti in the following sequence and packs it into her lunch box. Identify the folded roti.

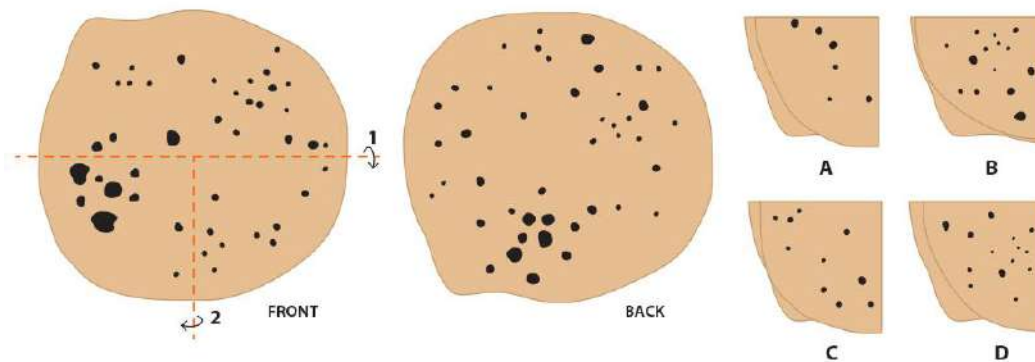

Q.79 An unwrapped cube is shown below. This cube has cuts of specific shapes on all sides. When the cube is folded, what would be the view as seen from direction X?

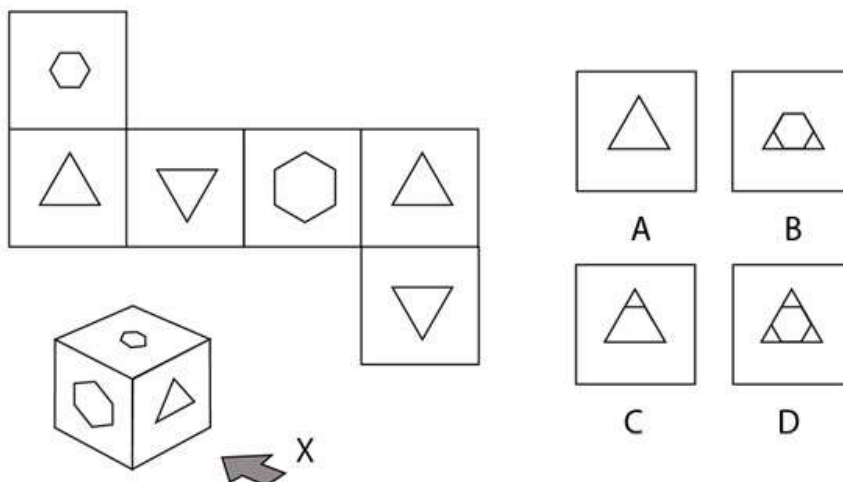

Q.80 The four figures below show a hand gripping a cylinder. In which of these figures, will the grip exert the maximum force?

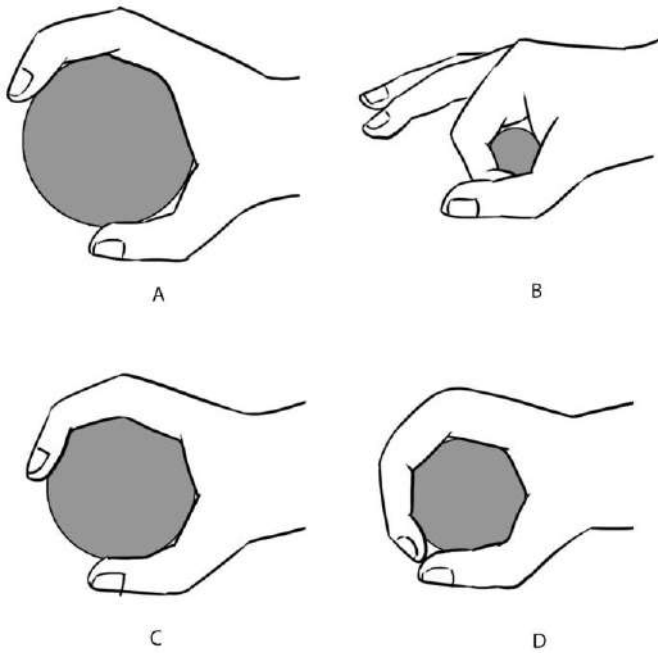

Q.81 Four cut-outs of shapes (labelled p, q, r, s) are shown below. Using one or more of the cut-out pieces, how many unique combinations can be made that will create a square/rectangle?

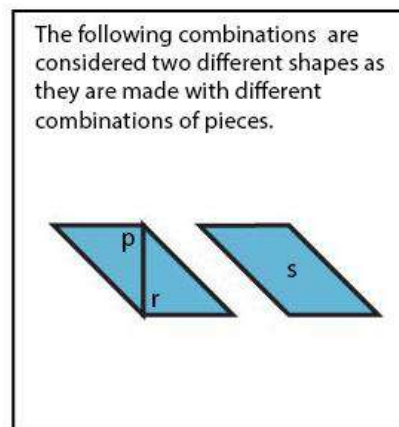
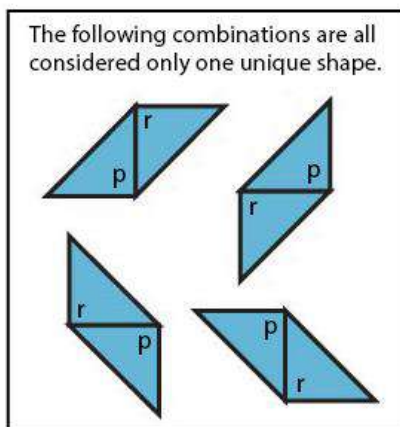
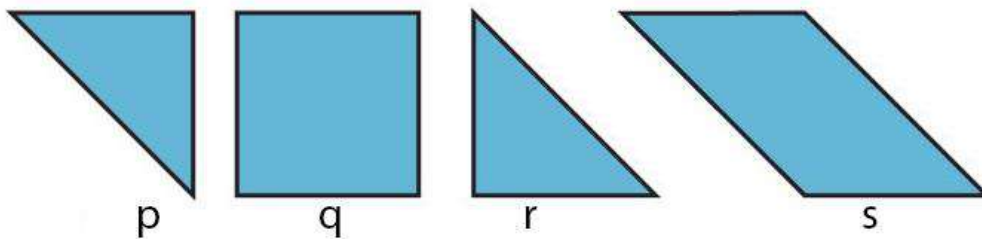

- A. 4
- B. 5
- C. 6
- D. 3

Q.82 The figures show simplified shapes of the neck portion of the vertebral column of a horse. Which of the options is most correct?

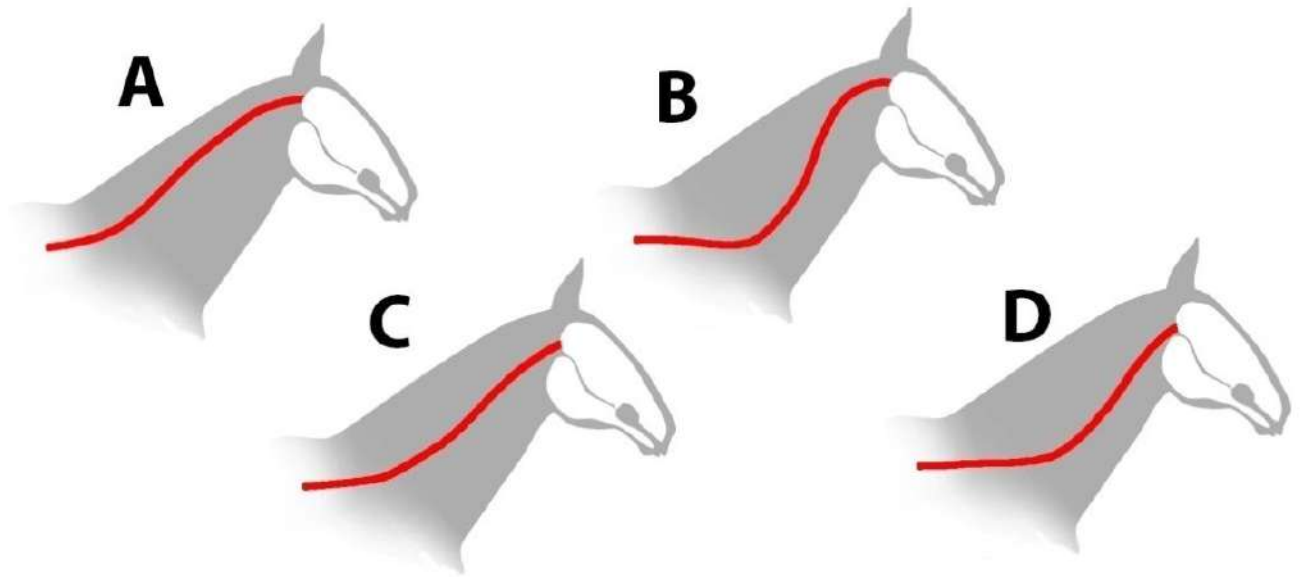

Q.83 How many times is the area of the outermost triangle compared to the area of the innermost triangle?

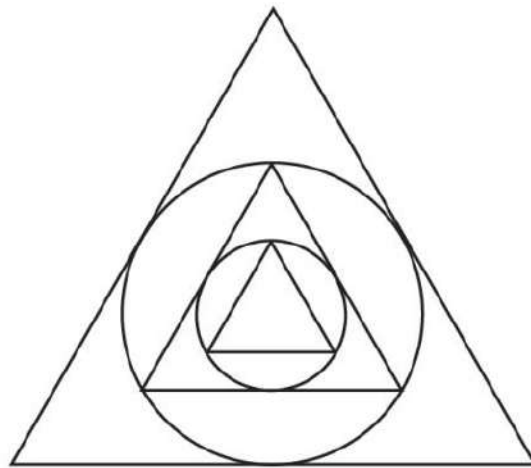

- A. 16
- B. 9
- C. 9.42
- D. 12

Q.84 Which option will replace the question mark as the frog jumps in an animation sequence?

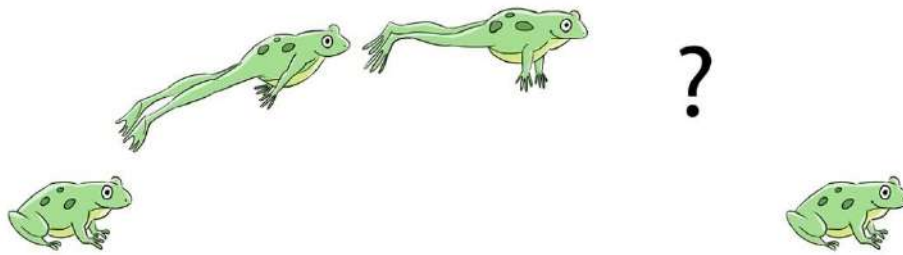

A



B

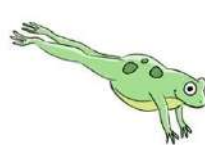

C



D

Q.85 Which option will replace the question mark?



A



B

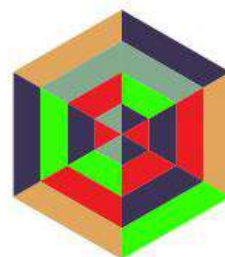

C



D