

CAREERS 360
PREPARATION Series

NID BDes

Question Papers
by Silica Institute (2016–2024)

NID DAT 2024



GAT Questions: (Part I)

1. How many wings does a dragonfly have?

Options: 2-4-6-8

Correct answer - 4

2. Which of the following heavenly bodies are of a similar nature?

- Earth, Sun, Moon, Alpha century, Halley's comet.

Correct answer - Earth & Moon (Similar Pair), Sun - Alpha Centauri - Halley's Comet (Similar Pair)

3. You are positioned in Delhi. If you travel to bhopal and then ahmedabad, What will be your direction of travel from bhopal towards ahmedabad?

Correct answer - West Direction

4. The human eye understands lightness and darkness by using rods and distinguishes colors by use of cones. Which parts of the eye help to control the amount of light entering it?

Options - Pupil, Retina, Eyelashes, Iris

Correct answer - Iris

5. Demography is the statistical study of which of the following?

Correct answer - Population

6. Match the following

Dokra	Chattisgarh
Madhubani painting	Bihar
Papier Mache	Jammu & Kashmir
Bidri Work	Karnataka

Correct answer - Dokra - Chattisgarh, Madhubani - Bihar, Papier Mache - Jammu & Kashmir, Bidri Work - Karnataka

7. Which of the following are right?

- The boiling point of water does not change at all locations.

- Boiling points of water depends on pressure.
- Oxygen is low at high altitudes.
- The air fuels mixture of any vehicle remains the same at all locations.

Correct answer - Oxygen is low at high altitudes

8. Which two pencils are on the same plane

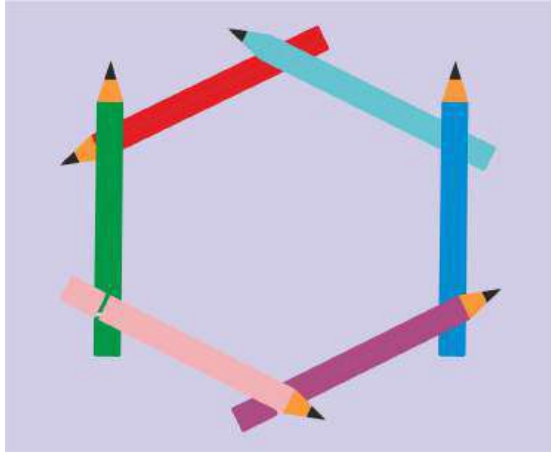

Correct answer - Green and Blue pencil

9. Night flowering plants are typically _____ in color.

- Green
- Purple
- **White**
- Yellow

Correct answer - White

10. Which is the most functional clock (hands of clock in different size)

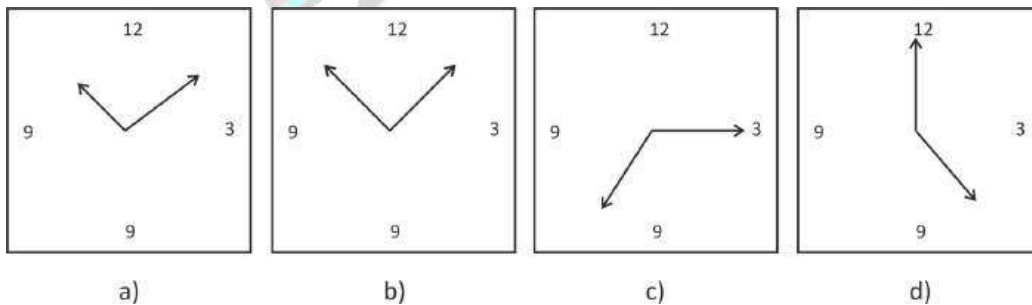

Correct answer - Option A

11. Relation between diversity and homogeneity.

Options - ?

Correct answer - Diversity is primarily focused on race and ethnicity while, homogeneity is usually focused on personality traits, attitudes and values

12. Relation between rights and duties.

Options - ?

Correct answer - Rights are what one want others to do for him or her while, duties are the acts that one should perform for others

13. Find from option a similar pair

Color wheel :

Yellow-orange/yellow/ yellow -green

Red/Orange/Red/Magenta

Purple/Blue/Green

Correct answer - Yellow-Orange-Yellow-Yellow-Green (Analogous colour scheme)

14.

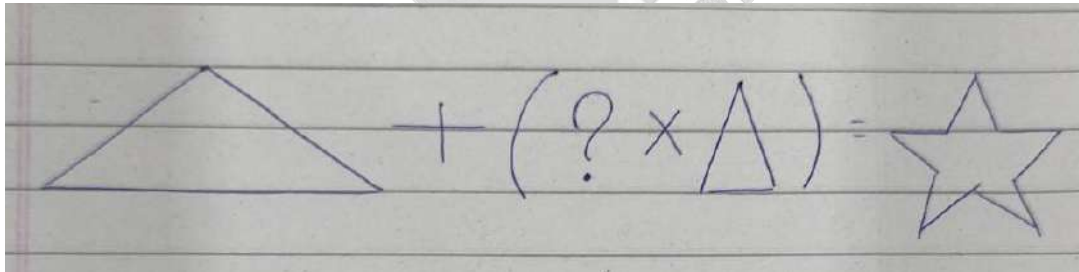

Options - 1, 2, 3, 5

Correct answer - Three

Drawing Questions - (Part II)

Q.1. Your objective is to replicate the given pattern in Image 3 to cover the entire paper. After that, illustrate the dotted lines and fold lines to represent how the paper would look after folding based on the information provided in Image 1 and Image 2.

Draw the opened paper with dotted lines to show the folds and shade in the cut outs

Images:

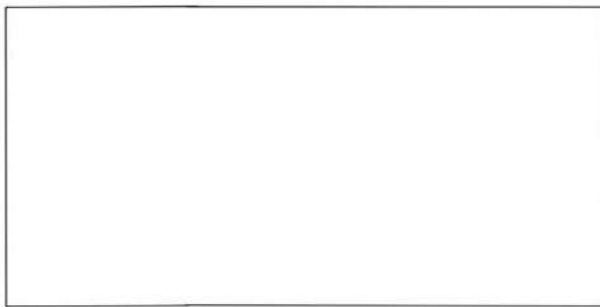
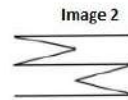
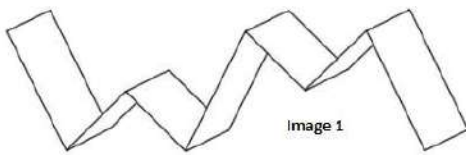

Answer -

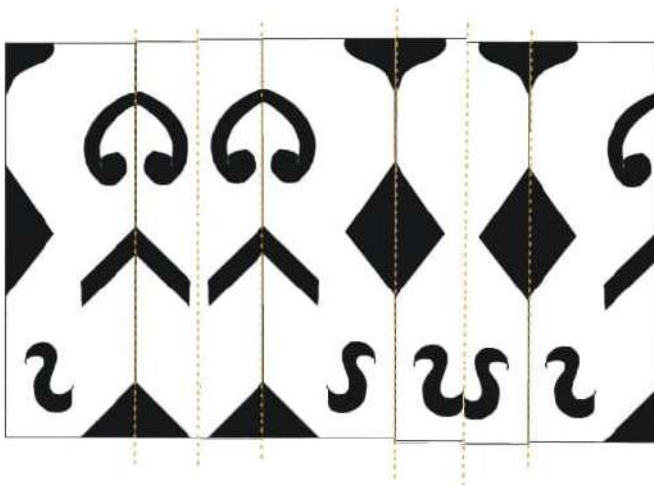

- Q.2.A.** - Create a product to carry 20 liters of water in a mountainous area (12 marks).
- Explain how a person can use this designed product effectively (8 marks).

Answer -

'The Easy Carrier'

Concept : In a mountainous environment, the minimalist design 'the easy carrier' would help grip a 20 litre water bottle with ease. Made out of stainless steel, it locks the top of the bottle and allows one to lift it like a bag. A person can easily lift and transport 2 bottles of 20 litres at a time OR 2 people can hold a single 20 litre bottle by holding one handle each.

Do's: Design a product that aids to carry 20 litres of water with ease on an undulating landscape.

Don'ts: Do not make a complex product that is not practical to use considering slopes of the terrain.

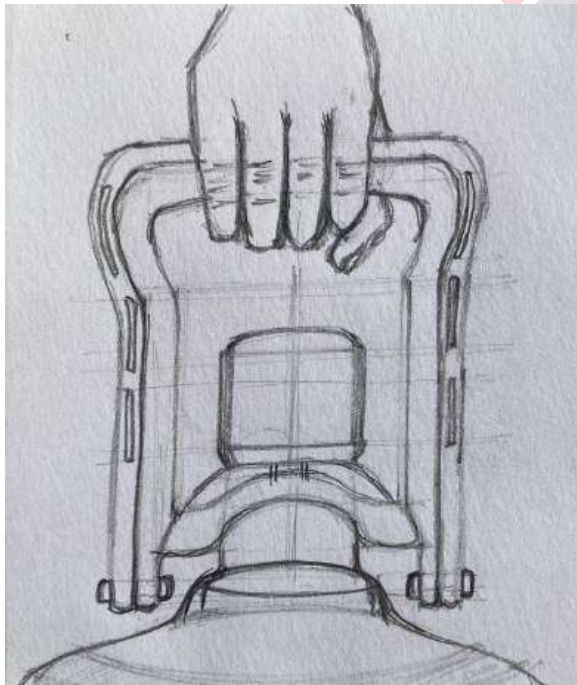

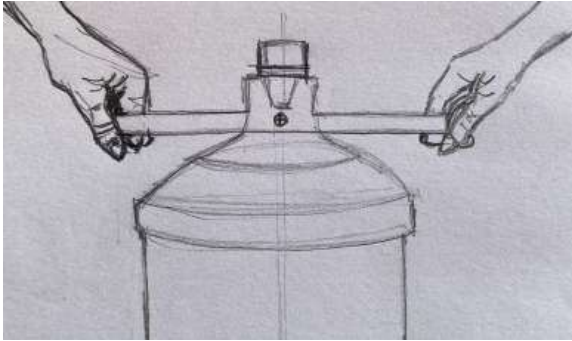

Q.3. Draw 3 key steps for the process Given below

- Potato to chips
- Bees to candle
- Mango/fruit to pickle
- Seashell/beads to jewelry

Answer -

'Three Step Process'

Concept: The process sketches illustrate the 3 steps of making Potatoes to Chips, Mango to Pickle, Beewax to candle and Seashells to Jewellery. The illustrations focus on the three key steps to its making.

Do's: Break down the process to quick illustrations in three important frames. The beginning, the middle and the end.

Don'ts: Do not illustrate a step that is not required. Do not use colors (not required).

1. Potatoes to Chips

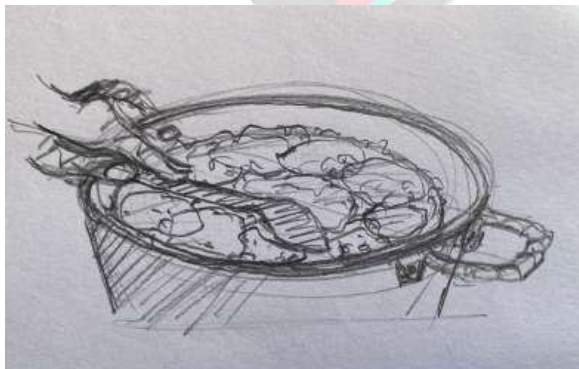
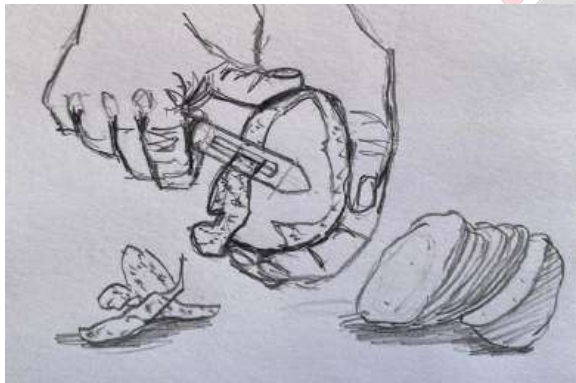



2. Seashell to Jewellery

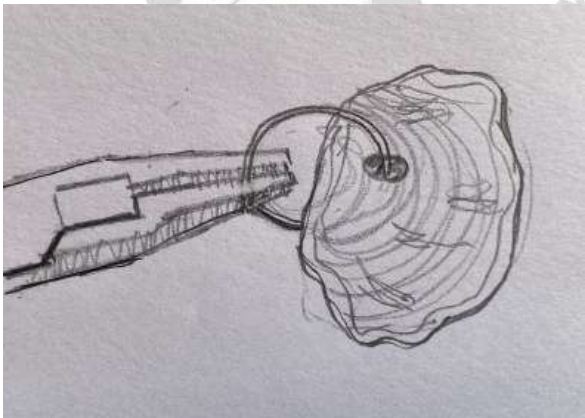
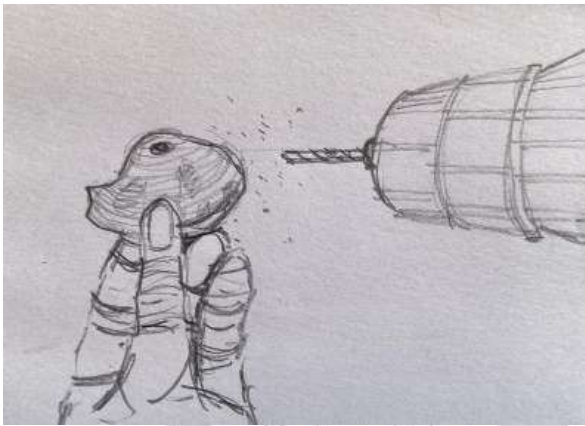

SILICA
YOUR DESIGN CAREER GUIDE

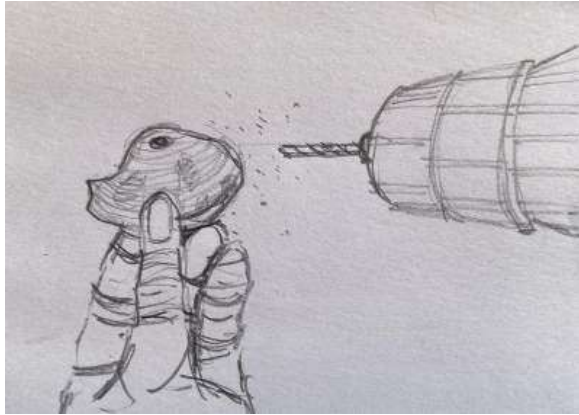

3. Beeswax to Candle

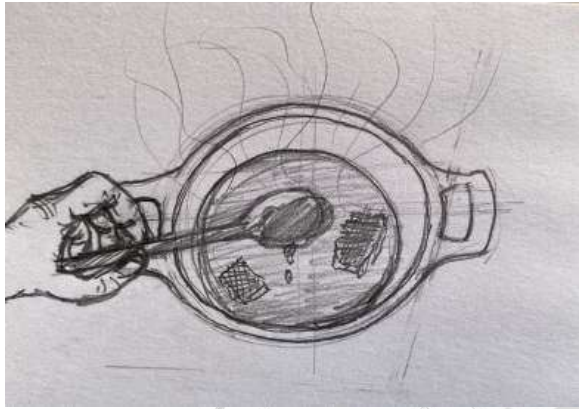

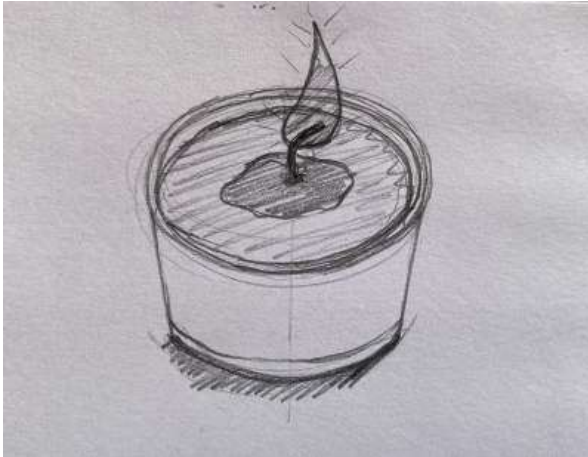

4. Mango to Pickle

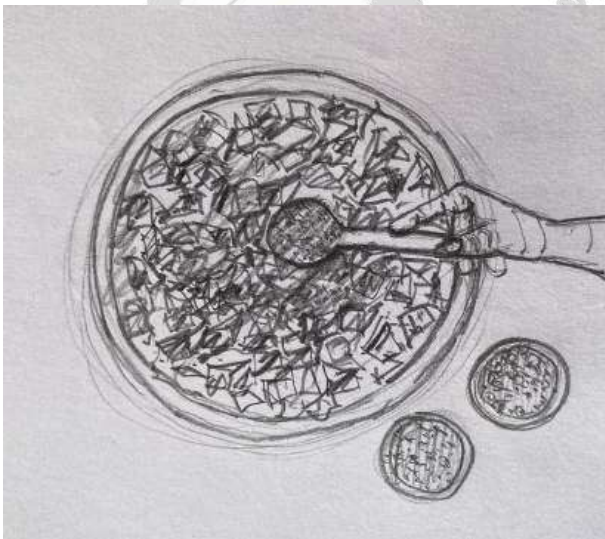
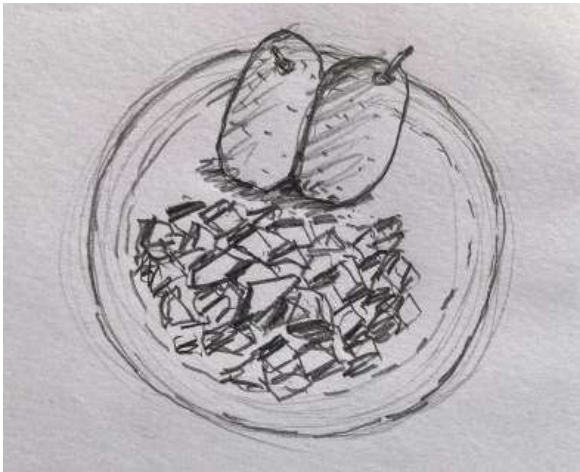

SILICA
YOUR DESIGN CAREER GUIDE



Q.4.A. Draw a room for a person above 50 years old or a child aged 6-10.

- Show where they would be positioned in the room.
- Write a key function / purpose of any product in the picture you draw.
- Describe ways to improve the functionality of the product

Answer -

‘Old man in a Room’

Concept: The illustration shows an elderly man sitting on a wooden rocking chair next to a window with a table lamp and a plant pot. He lives by himself and has relatives and guests coming to his abode every now and then.

The second sketch illustrates a floor lamp and a cushioned sofa. It will help the elderly man sit with comfort and provide softness to his body on the sofa. The table lamp is replaced with a floor lamp with an on/off string.

Do's: Illustrate any one option with the room, an elderly man or a young child of 6-10 years. Illustrate a bit of the environment with certain furniture and objects, then choose an object that can be changed for a better use.

Don'ts: Do not get into unnecessary detailing or ornamentation.



SILICA
YOUR DESIGN CAREER GUIDE

NID DAT Prelims 2023

B.Des Original Paper

Type: Paper based	Marks: Part A = 40 marks, Part B = 60 marks	Time: 3.0 hours
--------------------------	--	------------------------

Part A of NID DAT Prelims 2023 - B.Des Paper:

- Part A questions of the NID DAT Prelims paper are not available. Here is a description.
- There were 28 questions (Q.1 to Q.28) for 40 marks.
- There were 7-8 questions on General Knowledge.
- There were 7-8 questions on a Passage, like Comprehension.
- There 13-14 questions on Analytical Reasoning & Logical Thinking.

Part B of NID DAT Prelims 2023 - B.Des Paper:

- There were 4 questions (Q.29 to Q.32) for 60 marks.
- Each question was for 15 marks.

Q.29. A rat has suddenly entered from the **bottom right corner** and looks at this scenario. Draw the following image in the given space from a rat's perspective. (Do not use color) - **15 marks**
Image sourced from: Daily Life in South and Center Cameroon 09, a painting by Emmanuel Baliyanga.

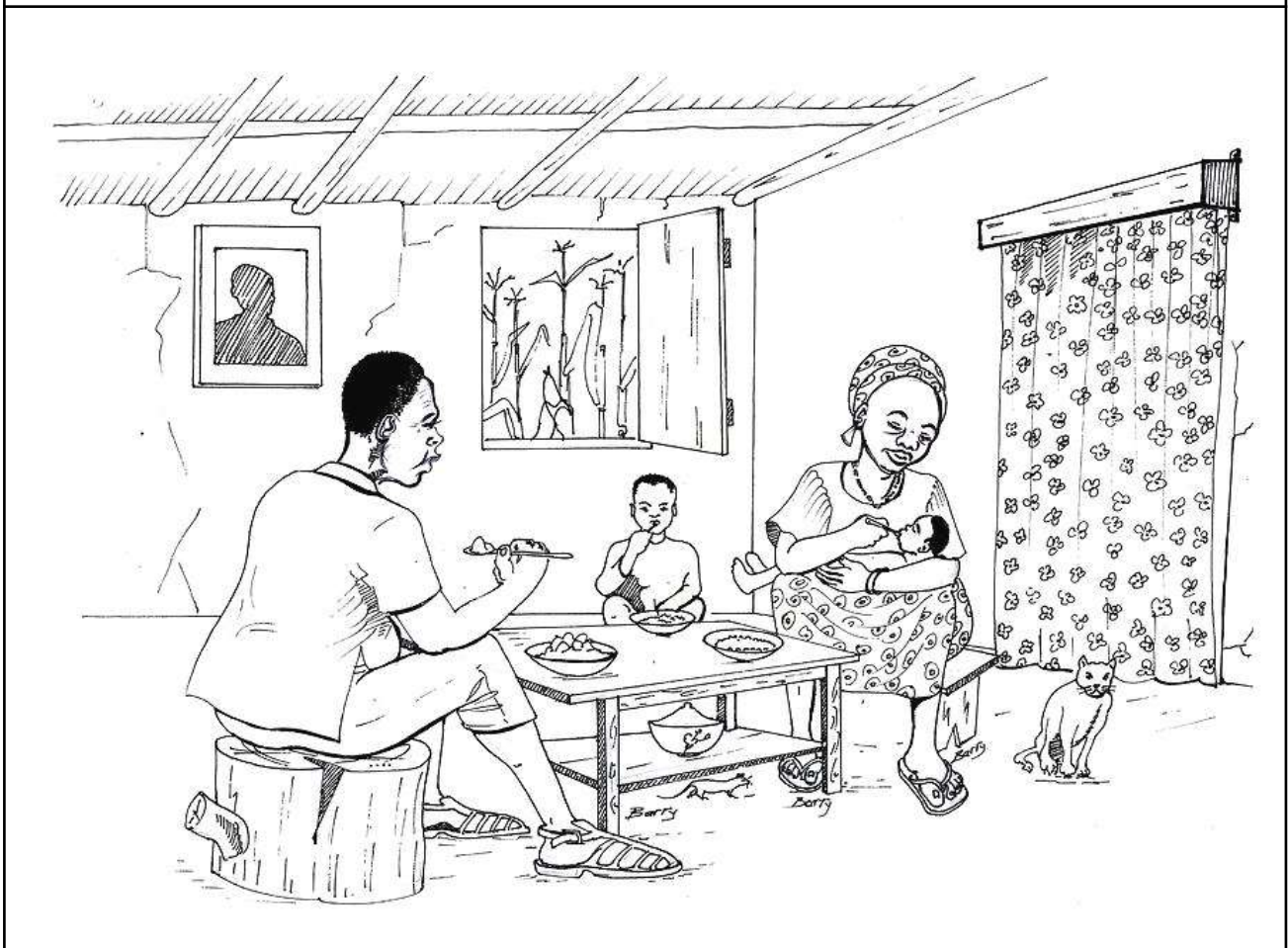

Q.30. Imagine how a **Bucket** and a **Dog** will be used in the short story which starts with the sentence: **“In the backyard of a house, a girl is sitting**

.....

and the story ends with the sentence:

“..... **at last, the bucket is filled with water**”.

Q.30A. Write the story in 150-200 words. - **6 marks**

Q.30B. Represent your story through drawing in the given three frames. - **9 marks**

--

Q.31. Shown below is an example where bad public behavior can be seen even after clear instructions are provided.

Draw 3 creative solutions of the problem shown in the given boxes. Explain each of your solution in 2-3 lines provided next to the frame. - **15 marks**



	<hr/> <hr/> <hr/> <hr/> <hr/>
--	-------------------------------

	<hr/> <hr/> <hr/> <hr/> <hr/>
--	-------------------------------

	<hr/> <hr/> <hr/> <hr/> <hr/>
--	-------------------------------

Q.32. Compose to make an instruction manual for depicting the following process using visuals & word labels in the following frames. **15 marks**

1. Sharpening pencil with a sharpener

2. Combing hair

3. Cutting nails

----- THE END -----



NID B.Des 2022

Original Paper

(Part B)



Q. 1- Modify / Redesign a Tap for:

- A 6 year old kid
- An artist
- A visually impaired person

Answer -

- **For a 6 year old kid**



Concept: For a 6 year old kid, the tap is playful in form and shape. It is safe for a kid to use as it is curved with no sharp edges and an easy to use knob for adjusting the water flow.

- **For an artist**

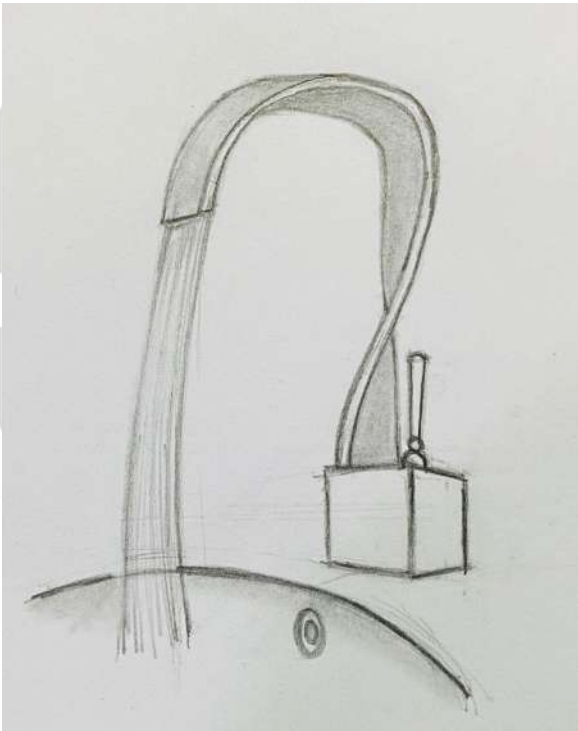
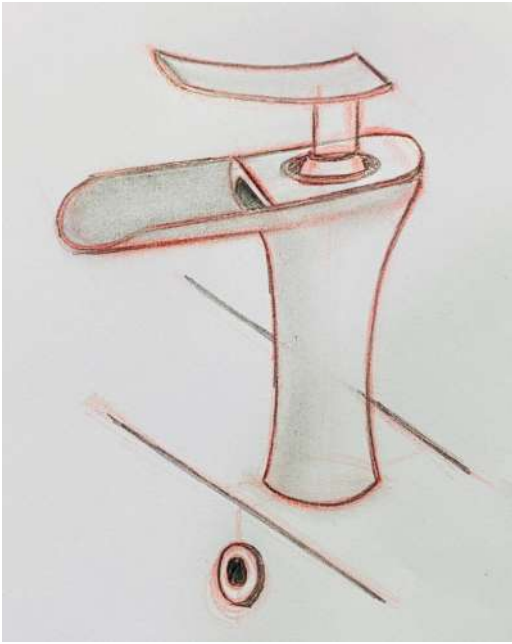

Concept: For an Artist, the tap is bold and artistic in its form. The water gently flows from the outlet like a river. The tap knob pivots up and down for easy use and control.

- For a visually impaired person

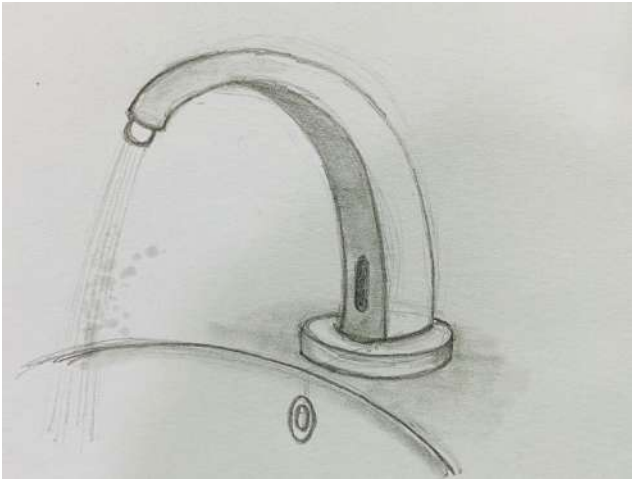

Concept : For a blind person, the water tap has a censor, a timer and a beep sound for automatically turning on and off the flow of water, when a hand is placed near it. The beep sound generated enables the blind person for awareness and a sign. It is a no touch water tap making it convenient for use. The flow of water is gentle on the hands and flows like a shower.

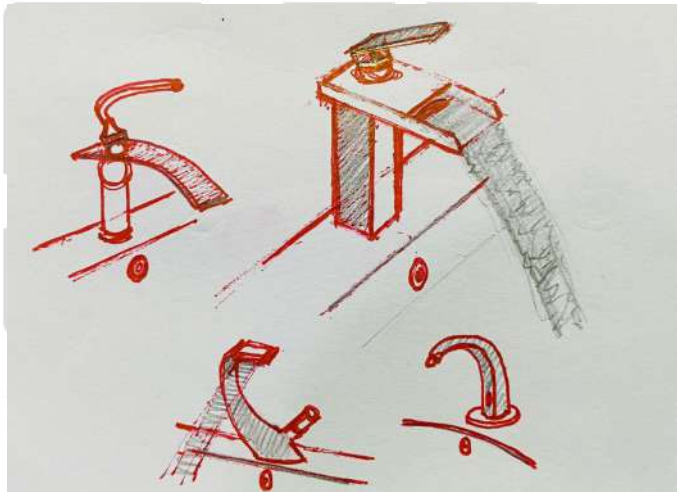

ICA
CAREER GUIDE

Do's: Try to finish all 3 solutions of water tap design within 20 minutes. Visualise in 3D, the overall form of the tap and it's user context. Make very quick thumbnail sketches for all in under 2 minutes for ideation. Think out of the box. You can also label your sketches with arrows for added information. Complete it on time.

Don'ts: Do not spend more than 20 minutes on the solution. Do not make the surrounding context and the kitchen. Only make the water tap design.

Visual Thinking

Q. 2 - Storyboarding of a heated argument between a Kingfisher(bird) and Fisherman.

Answer -



Concept: The story is illustrated in 4 frames. The kingfisher catches a fish from the fisherman's usual fishing spot. The fisherman is vividly angry with the annoying kingfisher for hunting his prey. He grabs the fish from the kingfisher's beak and swings the fish towards it, to whack the kingfisher. Terrified, the kingfisher flies away in anger, leaving the fish for the fisherman.

Do's: Make the storyboards in around 25 minutes. Quickly sketch out the basic composition in the boxes provided and then add details. Show depth in the frame to give context to the story. Focus mainly on the kingfisher and the fisherman. Choose frames which is easy to compose. Practice quick sketching.

Don'ts: Do not draw outside the box. Do not spend more than 25 minutes on the storyboard. Finish it on time.

Object drawing

Q. 3 - Draw a Cycle in correct proportion with the parts given below:



Answer -



Concept: This is a memory related solution. Visualise the cycle and draw a human figure riding the cycle to give scale and proportion.

Do's: Quickly draw the basic frame of the cycle from the given parts in 20 minutes time. Draw a side view of the cycle as it will give the viewer the best information. Make a human figure on the cycle to give scale and proportion.

Don'ts: Do not draw the surrounding context, it is not required or asked. Do not spend more than 20 minutes to complete the sketch.

Creative Memory Drawing

Q. 4 - Draw a room from the perspective of the person outside the window.

Answer -



Concept: The solution is all about perspective view and correct eye level. A person is looking inside the room from outside. The hand in foreground holding the window grill establishes the person looking inside and gives his/her point of view. The room is in 1 point perspective. The couple inside the room are admiring a photo frame sitting on the floor next to the bed.

Do's: Make the room in 1 point perspective or 2 point perspective, depending on your choice. Add human figures inside the room for giving scale and proportion. Add furniture, wall arts, lights, etc. to give an aesthetic look to the room. Complete the sketch in about 20-25 minutes.

Don'ts: Do not make a top view of the room. Do not make it in 2D. Do not take more than 25 minutes.



NID B.Des 2021

Original Paper

(Part B)



Q.1. Draw a scene of a student attending an online class and their sibling troubling them during the class. The scene should also include the scene inside the room eg. student's things, door, table, cupboard and anything else. (15 marks)

Answer :

Students attending online class & siblings troubling them during the class.

- environment not specified Students have attended classes while they were traveling, attending a function, relatives place or at home showcasing & sharing life experience can help
- relate it with real life & observe / remember your sibling did. The energy level needs to be showcased,
- details of the environment are important. Layout of keyboard, the app you're using and other things which need to be shown.
- You were helpless when your sibling was troubling you because your camera was on! How did your sibling make use of that opportunity ?

Step 1	Step 2	Step 3
1. Define eye level & Vanishing point 2. Create environment	1. Roughly place object & sibling with correct scale & proportion.	1. Start the detailing with the element closer to viewer

YOUR DESIGN CAREER GUIDE



A
GUIDE

Q.2. Illustrate and depict a funny conversation between X & O of tic-tac-toe in six square boxes.
(Marks 5)

Answer :

- Funny is difficult, Funny is Subjective.
- 'X' 'O' characters! There can be more which are not mentioned, They can help add value to story too.
- A good story always has some comparison or Contrast
- Having a beginning & end is important (connecting two then becomes easy.
- Be a character & think!
- In this scenario. I played the game to see what the conversation could be! It helps.

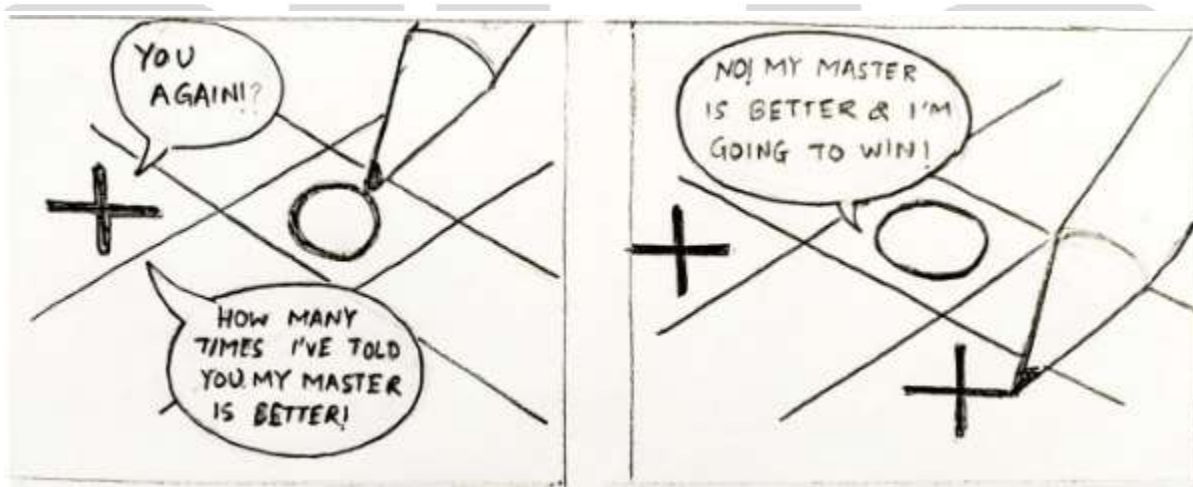

A
GUIDE

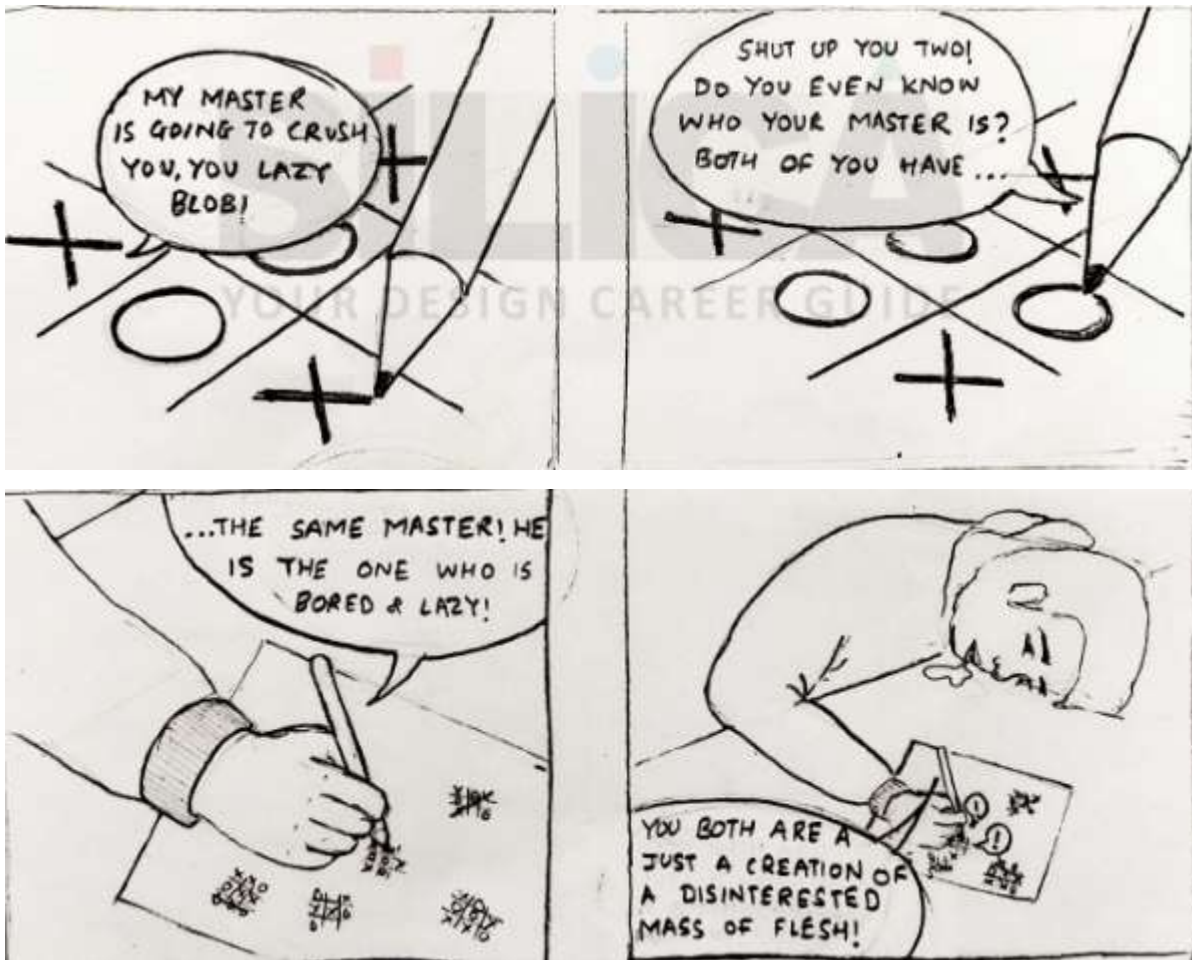

YOUR DESIGN CAREER GUIDE

Q.3. Look at the picture story below and write your interpretation of the story in less than 100 words (5 marks)

- Observe the element in the picture.
- Give names to the characters.
- Think as if it was happening to you. Can you relate to such an incident ?

One fine Summer evening, Leela got a piece of cake to eat. Leela's mother Lata insisted Leela go out & play baseball with her friends and eat the cake. Disappointed Leela had No choice but to go out and play. but knowing Leela's nature, Lata Decided to hide the cake & play a prank on her saying a rat ate the cake. As expected, Leela. Tried to Sneak's inside house as she Could stop her irresistible urge to eat, Her excitement Was shot down She Started crying As the cake was nowhere to found where She & her mother kept it safely.

Q.4. Create and design Poster against “bullying“ (15 Marks)

- Are you aware of this type of bullying ?
- Were you bullied ever? Have you ever bullied anyone? why? understand the reason to express why bullying is bad ?
- Simplify elements. Symbolic/ abstract illustration will be helpful.
- Do not use topic /theme name as caption) create your own
- emphasize on a certain element! Avoid multiple elements.
- Mountain balance & hierarchy



SILICA
YOUR DESIGN CAREER GUIDE

FOOL

TUPO

TUPIO

LOSER

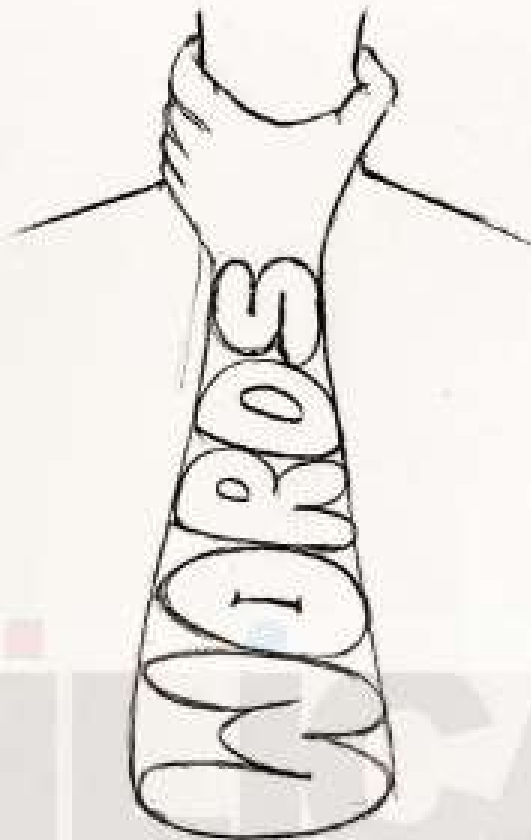

ABUSE HAS MANY FORMS

!YOUR WORDS CAN BE SUFFOCATING!

SAY NO TO BULLYING!



TAKE A PLEDGE TODAY!
#beabuddynotabully



www.beabuddily.com

SCAN FOR
MORE



5. In 6 square boxes, illustrate in steps the process of making tea. (10 marks)

- Make a list of the process
- Every frame needs to have some importance like if the flame is high or low the position of 4 knobs with matter!
- Cleaning part and precaution will be important too!
- Draw the final outcome in the environment?

SILICA
YOUR DESIGN CAREER GUIDE

STEP 01

1/2 cup water
1/2 spoon sugar
⊕ full flame
Ⓛ 1 minute
OR
till it boils

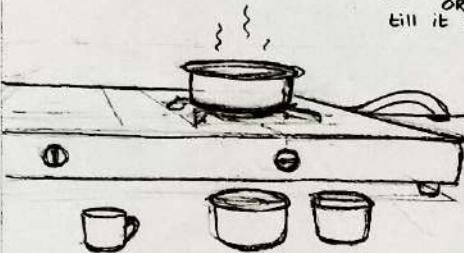

Take 1/2 cup water, 1/2 spoon sugar & put it in a vessel on full flame for a minute to make tea for 1 person

STEP 02

1/2 spoon tea leaves
OR
some ginger
OR
some Masala
Tea powder
⊕ low flame
Ⓛ 1 minute
OR
till it boils

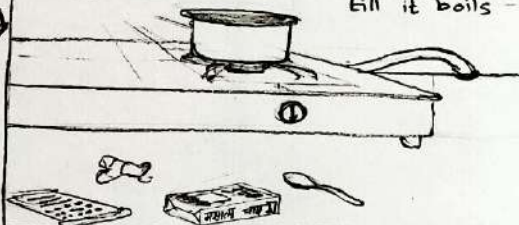

Add 1/2 spoon tea leaves, some ginger or masala tea powder & reduce the flame to low.

STEP 03

1/2 cup Milk
⊕ low flame

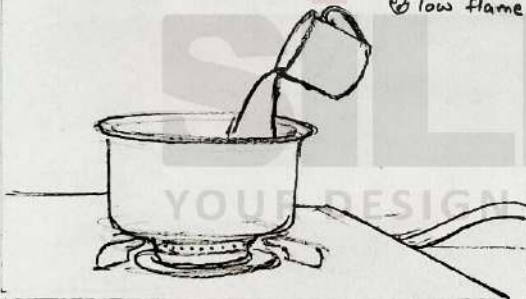

Add 1/2 cup milk to the boiling water. You can add boiling milk later on in the cup directly too.

STEP 04

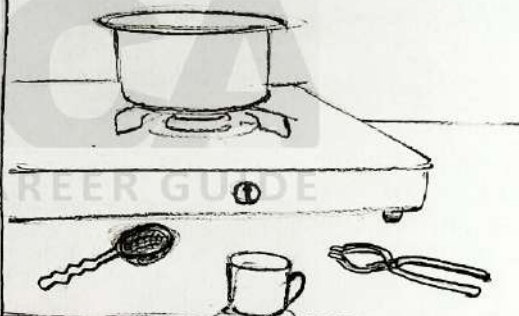

Take a clean strainer & a cup & pour the tea carefully with the tongs.

STEP 06



ENJOY THE HOT TEA!

STEP 05

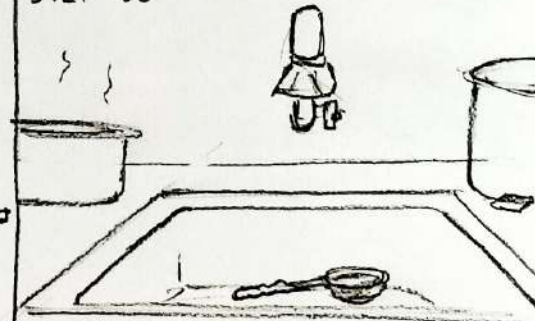

Do not forget to throw the tea leaves in the dustbin. Do not put the hot vessel directly under the water for cleaning.



राष्ट्रीय डिज़ाइन संस्थान
NATIONAL INSTITUTE OF DESIGN

NID B.Des 2020

Original Paper

(Part B)

SILICA
YOUR DESIGN CAREER GUIDE

Q.1. An Open view(2D) of a box was given, students had to draw the 3 sides of the 3D cube. 5 Marks

Answer -

a) Understand:

- Identify the flow of lines.
- Motion and movement across 2D surfaces.
- When folded how are lines moving
- Visualize a rough 3D folding cube.

b) Idea:

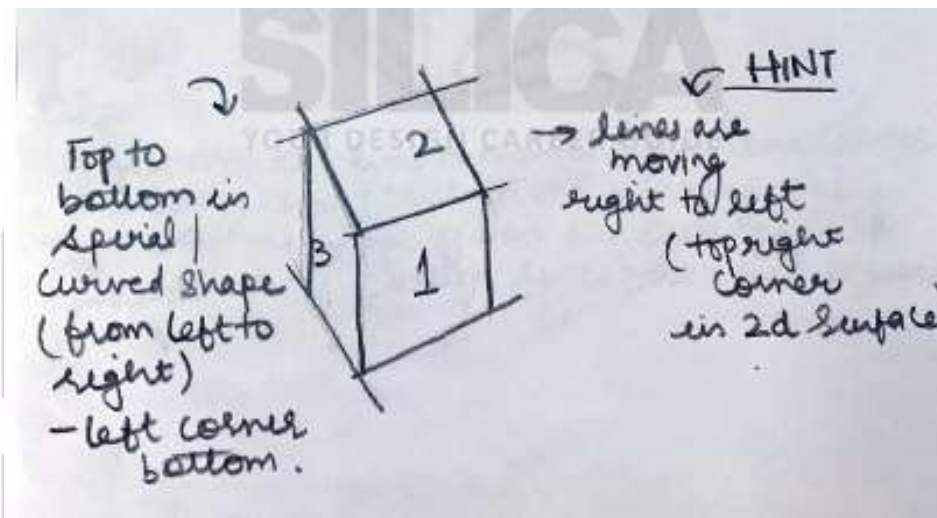

Ps - Understand the pattern of line first, when tilted how they are moving in 3D Surface.

c) Present -

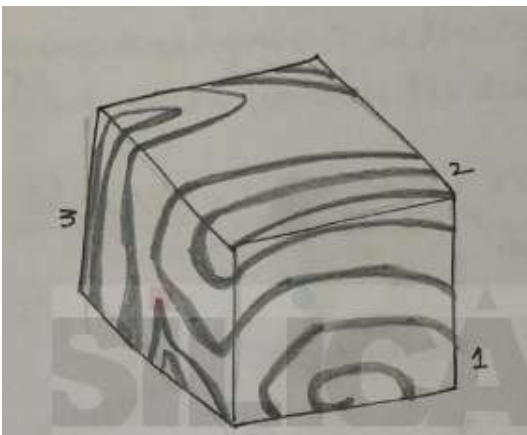

Ps. Understand the line movement from one corner to another and focus on the marking only. Try filtering the shape given in ques. Paper & understand the cutting lines from one square to another.

Q.2. A view of the kitchen given in 2 point perspective from a man's eye level. Draw that same view from a point marked on the picture, and from a 3 year old's point of view. 13 Marks

Answer -

- a) Understand -
- Perspective given from X point of view
 - Understand the size and proportions of the element.
 - Placement and alignment is the key to drawing.
 - Close your eyes and visualize the scenario.

B) How to ideate - Look at the vanishing point in the give image.

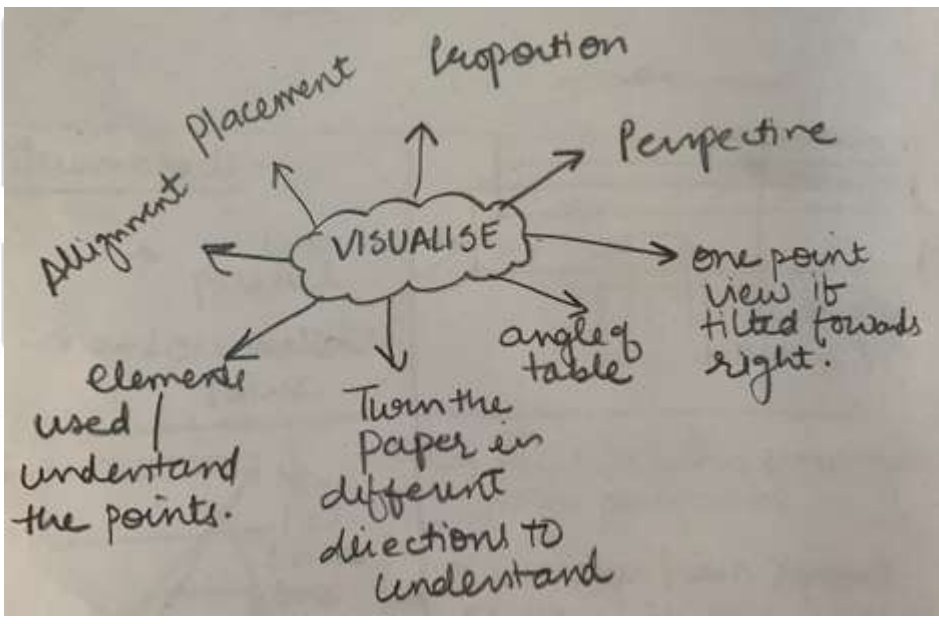

Ps - understand the corner and vanishing point given from the X point of view.

c) How to present -

(C) HOW TO PRESENT:-

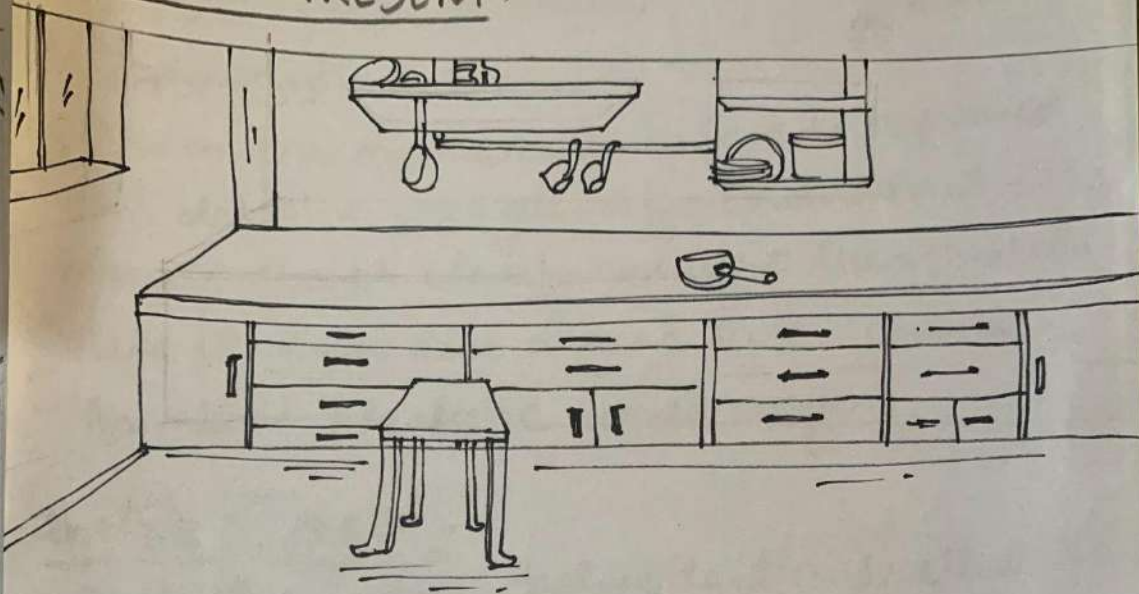

Thumbnailes:-

- lines parallel
- and one Vanishing Point

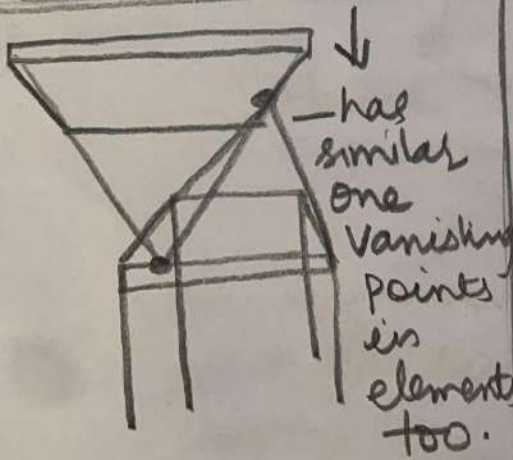
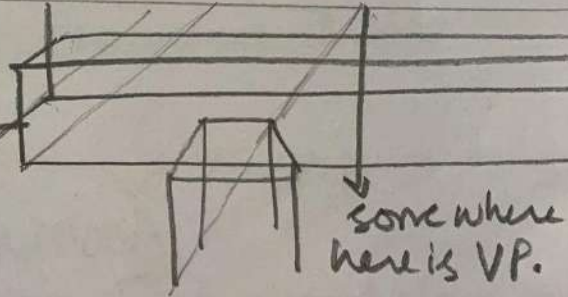

- Point is given from two point perspective
- where as from X point of view, it is one point perspective.
- Identify lines || to each other & Vanishing points



Q.3. Give 5 humorous ways of using an old bulb. Draw and explain. 15 Marks

Answer-

a) Understand -

- Think of creative unusual uses.
- Observe surroundings, replace material to come up with creative ideas.
- The ideas should be funny, creative & usable.

b) How to ideate-

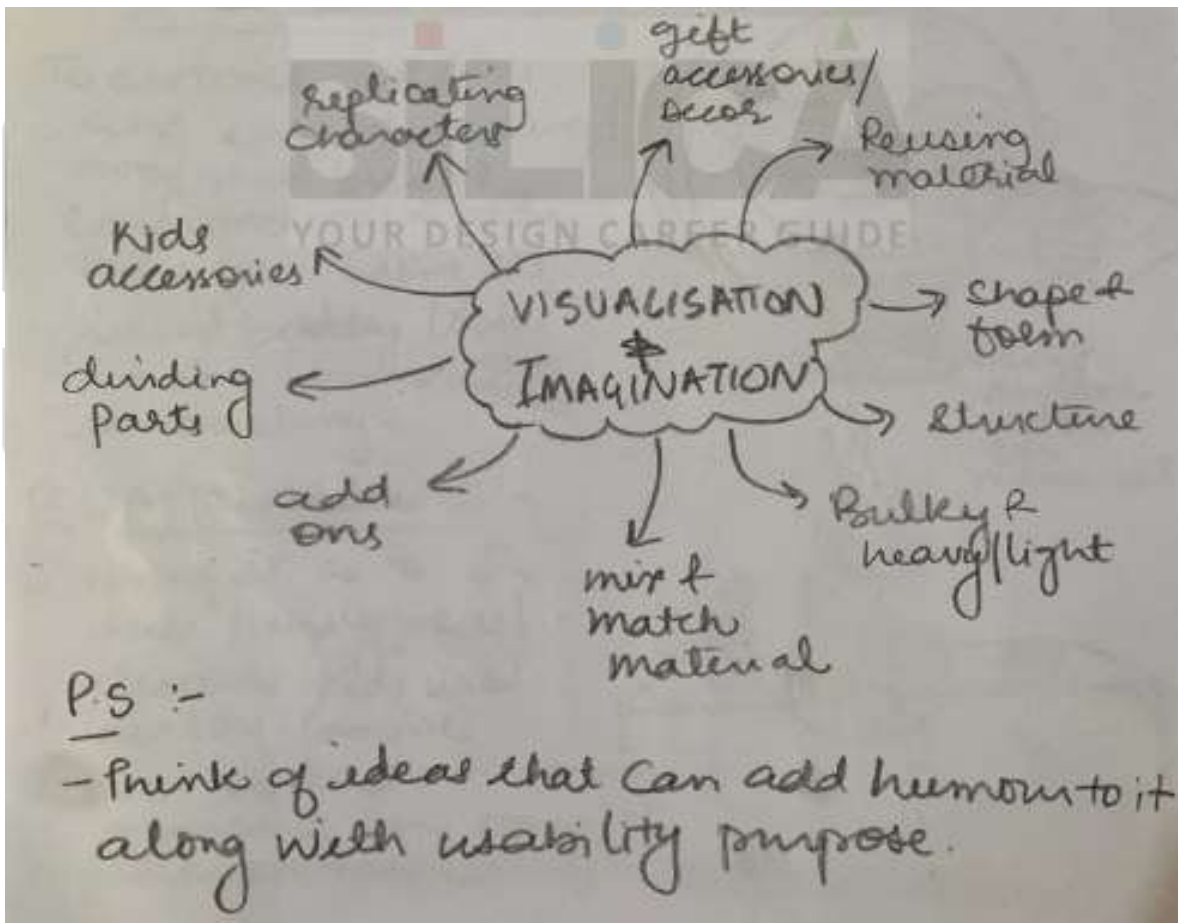

Ps- Think of ideas that can add humans to it along with usability purposes.

c) How to present - Think of creative yet usable & Feasible ideas.

I. Halloween Character - Sketching the idea by using the form of the bulb and glow in the dark purpose to add more humor to an event.



ii. Bobble head - To distract toddlers and infants creating a toy that breaks concentration & has more fun. Using its sound bulky look to make it more interesting.



iii. Gifting/Decor - Using its as a decor/Funny piece/element kids use as a toy. Can be use for decor or saying memories can hang/Place on table.

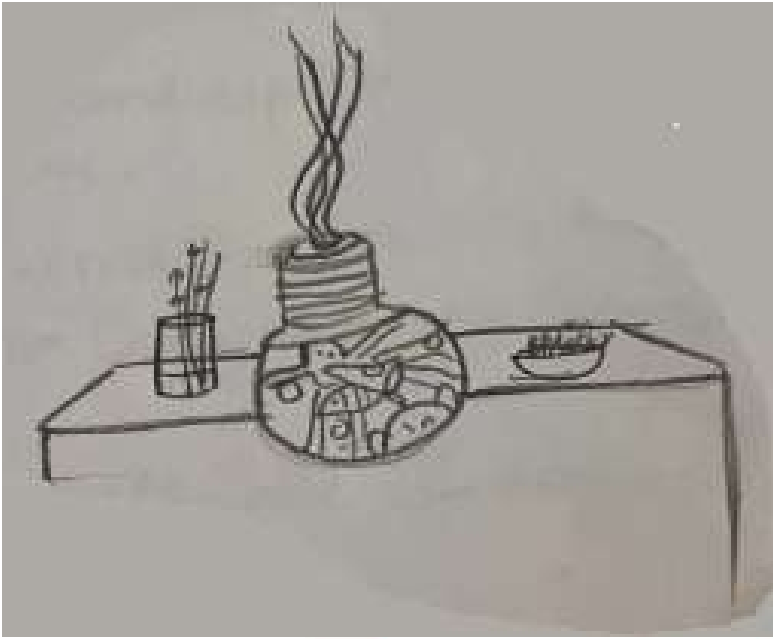

iv. Toys - Creating topy with different expressions and bodies. This can help them in learning about emotions as well as characters. The character hug him self if you hit it or touch it.



v. Astronaut craft - Using it as an astronaut craft where kids can play as a role play toy. Making your character wear clothes in a different way.



Guidelines -

- Think of using elements around.
- Observe funny things and replace or add them into existing ideas.
- Think of adding raw materials or mix and match.
- Creating unusual ideas can make you score more.
- Add extra details/Materiel if required.

SILICA
YOUR DESIGN CAREER GUIDE

Q.4. Design three defensive mechanisms for trees so that they do not get cut down. 15 Marks

Answer-

a) Understand -

- Think of the existing mechanism nature has.
- Ideas can be wild or wacky , But terribly related to touch me not flowers types of mechanism.
- Ideas should be several defenses and also should depict creativity.

b) How to ideate - ideas need to be designed keeping in mind nature & advanced technologies.

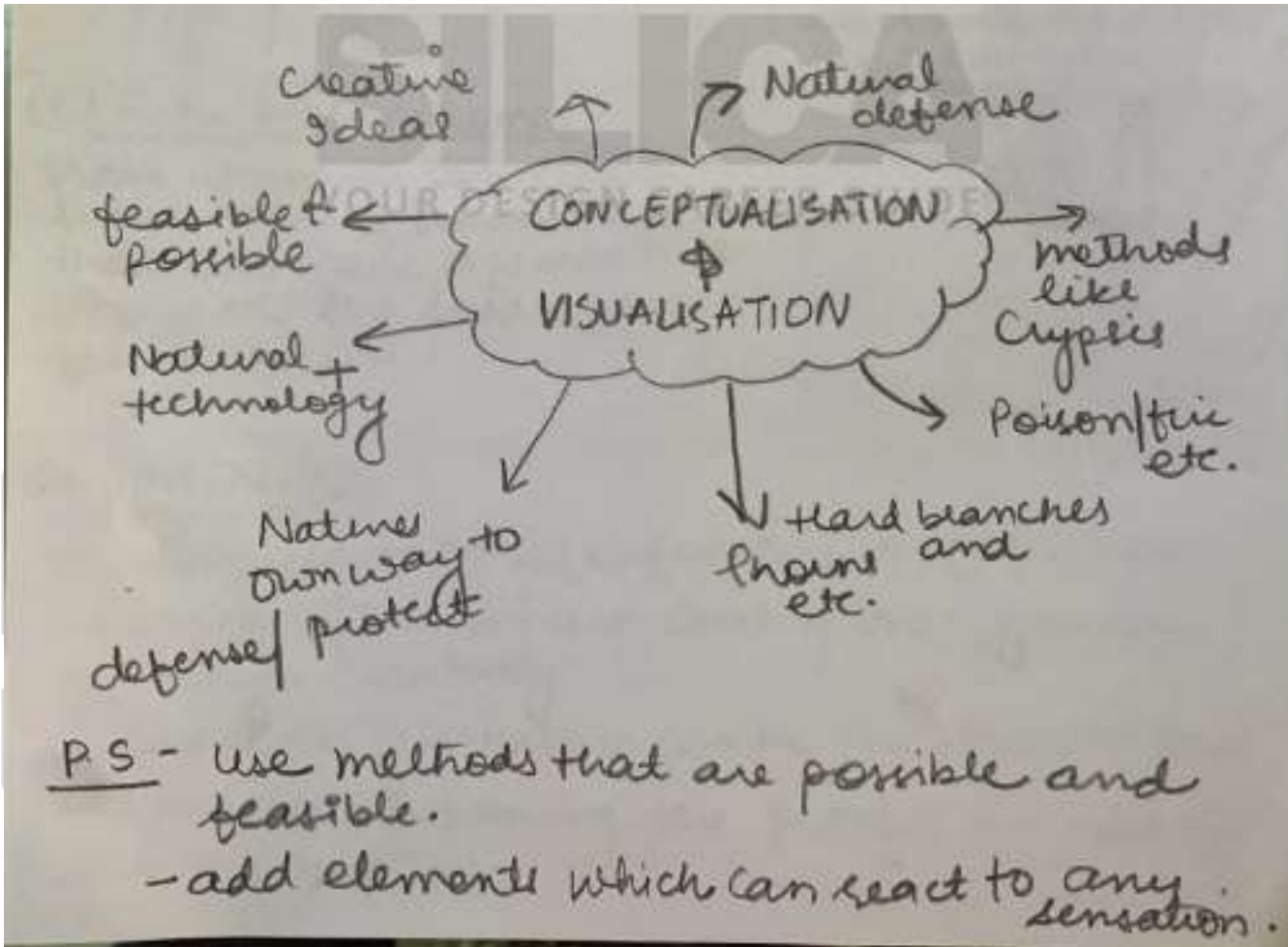

c) How to present -

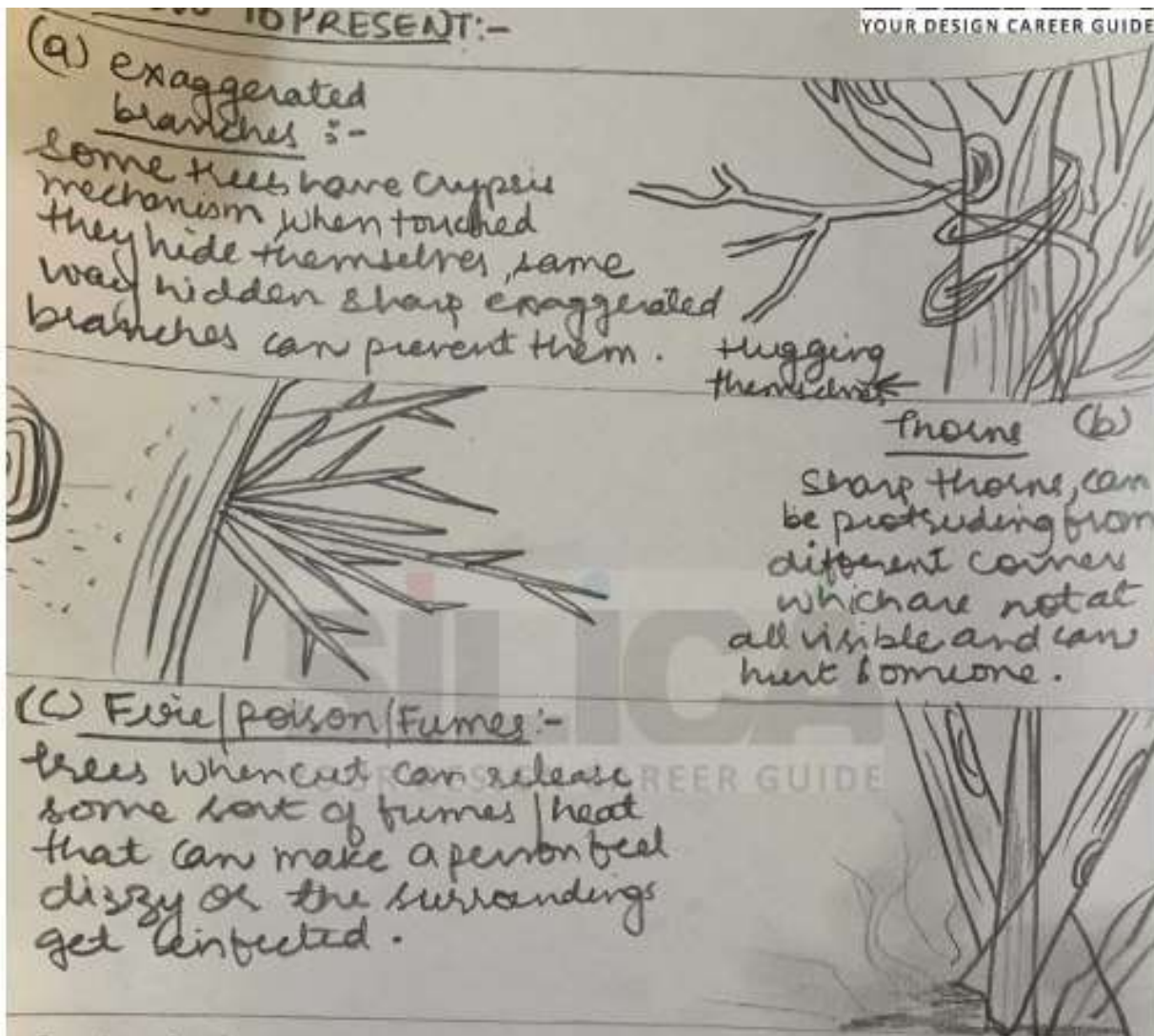

YOUR DESIGN CAREER GUIDE

d) Guideline -

- Visual presentation and defense is the focus here.
- Wax/Glue/Poison are existing ones you can use creatively.
- Sharpness in nature can be a plus point to use.
- Focus on mentioning the process in each of the mechanisms.

Q.5. Ravindranath Tagore once said, "Where the mind is without fear and the head is held high, where knowledge is free..."

The poster depicts the meaning and gives a tagline to it. 10 Marks

Answer -

a) Understand -

- Poster design is a part of visual communication. Focus on easy yet eye catchy, Attractive visuals.
- Tagline is a must, Always look for suitable idioms and phrases/Create one.
- Think about proper breathing & spaces & Alignment.

b) How to ideate -

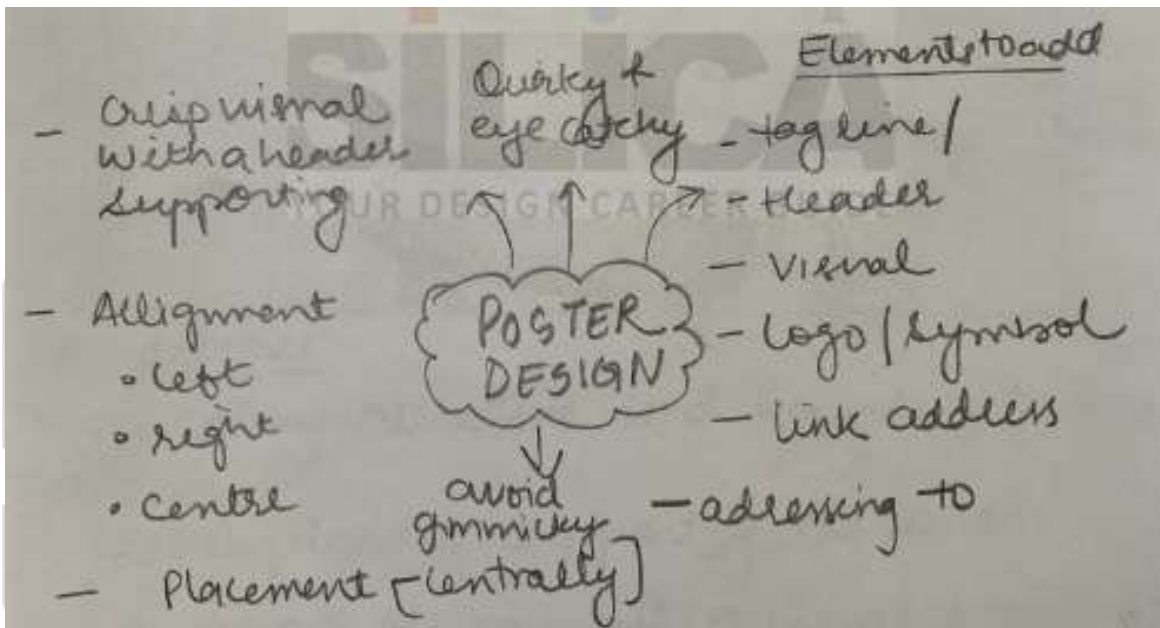

Ps. - Keep in mind, the visual should always compliment the tagline & Vice versa. Use indirect messages to depict the theme.

c) How to present -

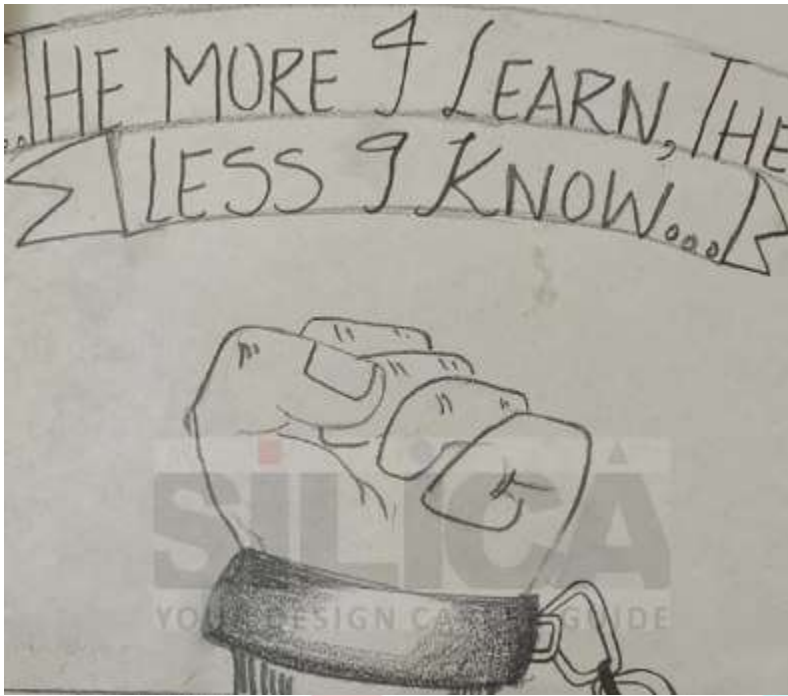

Guideline -

- Eye catchy, attractive visuals according to the theme.
- Tagline/Header should support visuals.
- Placement and alignment of visual & tagline.
- Tag depicting 3D elements in visuals & avoid 2D elements.

1. A person was sitting under a jamun tree and there was a pumpkin patch. The person thinks that the tree is so big but has tiny jamun fruit and wouldn't it be better if the tree had pumpkins. This was a storyboard question and students had to draw it in the three spaces given. 12 marks

Answer -

Answer -

- a) Understand:
 - Focus on the main situation/event happened.
 - Add a detailed foreground/Background to it.

- Visuals should clearly highlight the situation.
- Make it look like a real life scenario.
- Animated/Realistic should work.

b) How to ideate-

- Think of a suitable timeline to it and illustrate major events that happened after mind mapping.

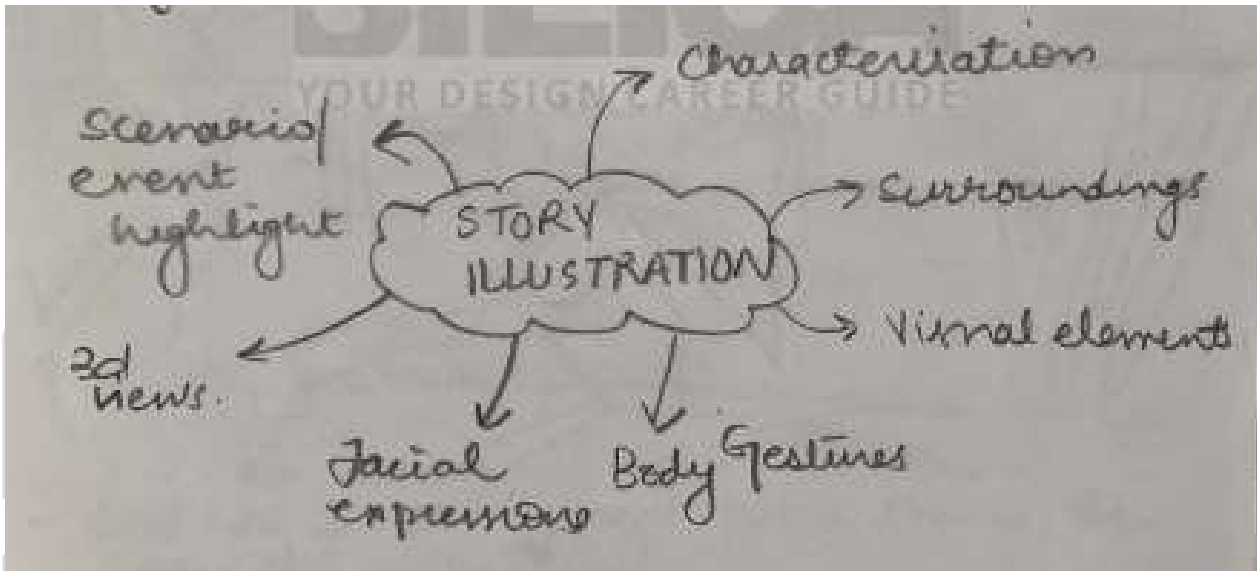

Ps - Keep in mind, detail of the area along with the same size character & proportion.

c) How to present:

YOUR DESIGN CAREER GUIDE

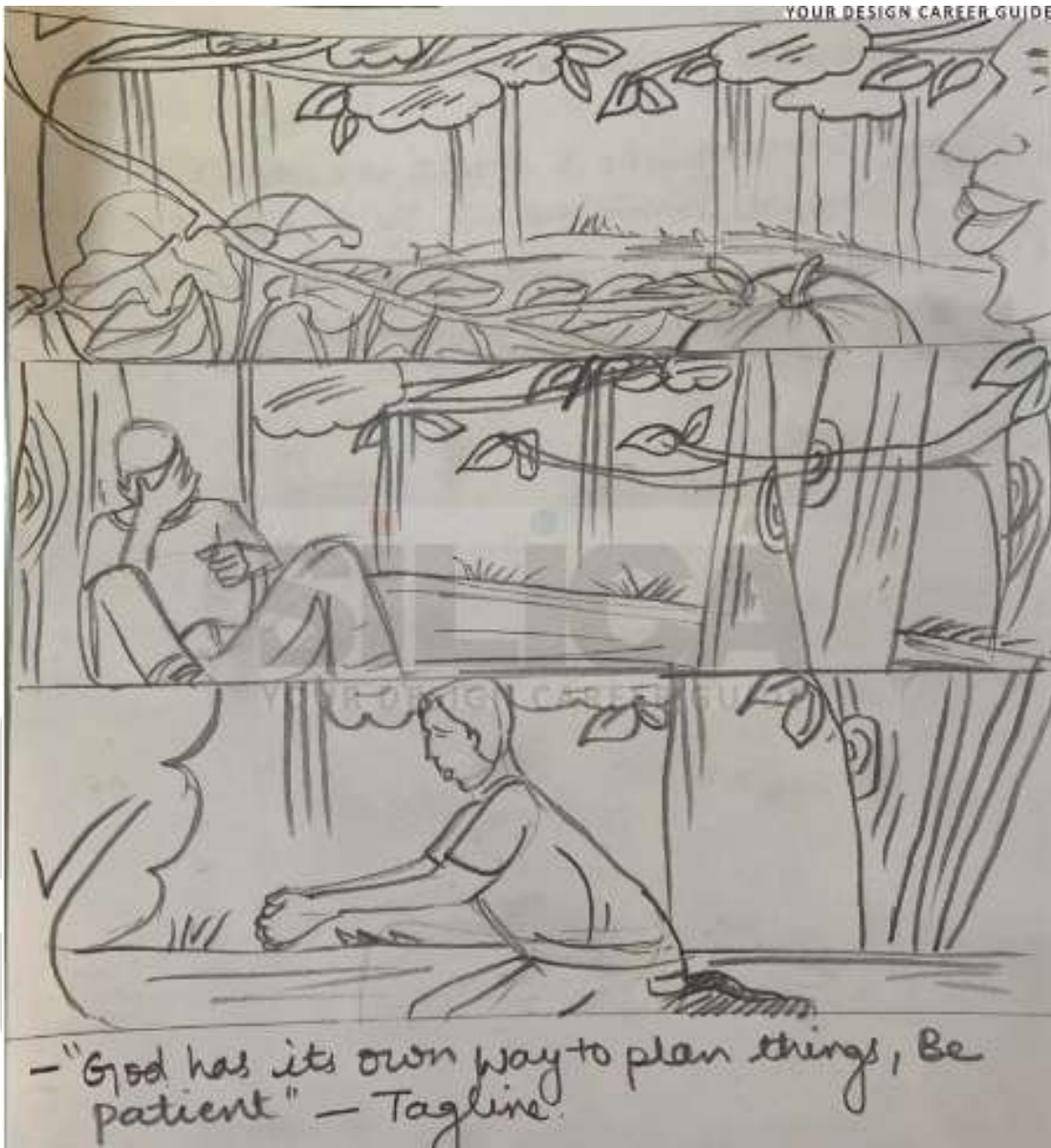

Guideline :

- Don't overdo the detailing by hiding character or the background.
- Focus should be on events & illustrations.
- Don't use text in between lines.
- Visuals can be cartoon, animated or real.
- Focus on detailing of human body/Gesture.

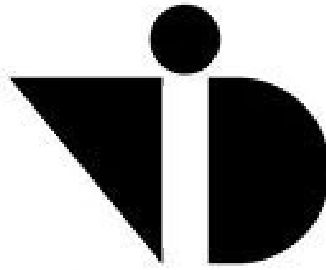

राष्ट्रीय डिज़ाइन संस्थान
NATIONAL INSTITUTE OF DESIGN

NID B.DES 2019 Original Paper Solved From

SILICA
YOUR DESIGN CAREER GUIDE

B.Des./GDPA

DAT Prelims 2019-20

Part I

Questions 1 to 22 are multiple choice questions. Please read the question carefully and select your response from the options provided. The correct answer must be marked in the OMR answer sheet provided separately. Do not write your name anywhere in the booklet. This will lead to disqualification.

Question Nos. 1 to 14 carry 1.0 mark each.

Q1. The icon below is associated with:



- (A) Women (B) Gay
(C) Labour (D) Transgender

Q2. Match the following line strokes with the related tools with which they were created, depicted in sequence from left to right.



- (A) Pen, Flat brush, Calligraphy pen, Round brush
(B) Calligraphy pen, Round brush, Pen, Flat brush
(C) Pen, Round brush, Calligraphy pen, Flat brush
(D) Calligraphy pen, Flat brush, Pen, Round brush

Q3. Which textile craft does the image below represent?



- (A) Kalamkari (B) Tie and dye (Bandhani)
(C) Ikkat (D) Block print

Q4. Which of the following DOES NOT belong with the rest?

- (A) Wool (B) Cotton
(C) Jute (D) Coir

- Q5. Which of these dance forms is NOT a classical dance form?
 (A) Bharatnatyam (B) Manipuri
 (C) Odissi (D) Bihu
- Q6. Annapurna Devi was a famous player of which instrument?
 (A) Sitar (B) Sarod
 (C) Surbahar (D) Sarangi
- Q7. What is the inspiration for the design of the front portion of the Japanese bullet train?
 (A) Cheetah (B) Eagle
 (C) Kingfisher (D) Dolphin
- Q8. During ancient times, people used to navigate with the help of
 (A) The planet Venus (B) The Phases of the moon
 (C) The Pole star (D) Birds
- Q9. Which of the following Indian personalities is NOT known as an artist?
 (A) Raja Ravi Verma (B) Raja Rammohan Roy
 (C) Rabindranath Tagore (D) Ramkinkar Baij
- Q10. Which is the highest sporting award in India?
 (A) Rajiv Gandhi Khel Ratna Award (B) Dronacharya Award
 (C) Dhyan Chand Award (D) Maharaja Ranjit Singh Award

- Q11. Which diagram shown below can best depict the relationship between the following 4 words – Boys/Girls/Sister/Sibling, where each of the categories are represented by circles/eclipses.

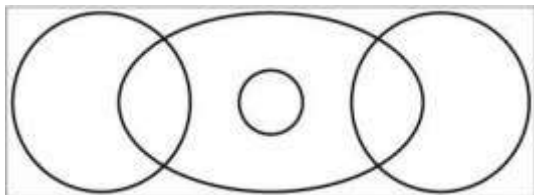

(A)

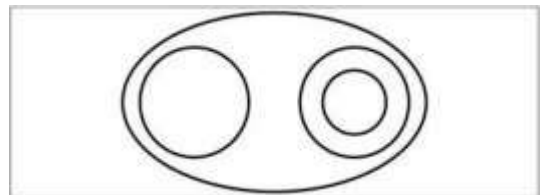

(B)

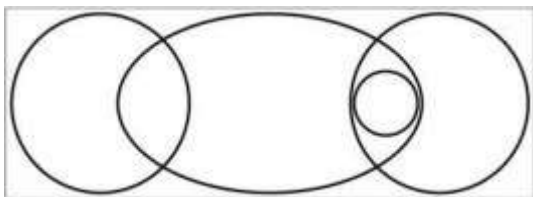

(C)

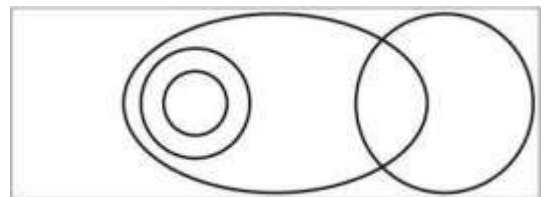

(D)

- Q12. The weight of a mother and her child together is 70 kg. The weight of the father and the child together is 90 kg. The weight of the father and the mother together is 120 kg. What is the combined weight of the family?
 (A) 100 kg (B) 150 kg
 (C) 140 kg (D) 200 kg

Q13. Based on the graphical representation (Figure X) of the physical characteristics of the 4 rectangles – P, Q, R & S based on the four characteristics of *tall*, *thin*, *short* and *fat*, which of the following depiction of rectangles is correct?

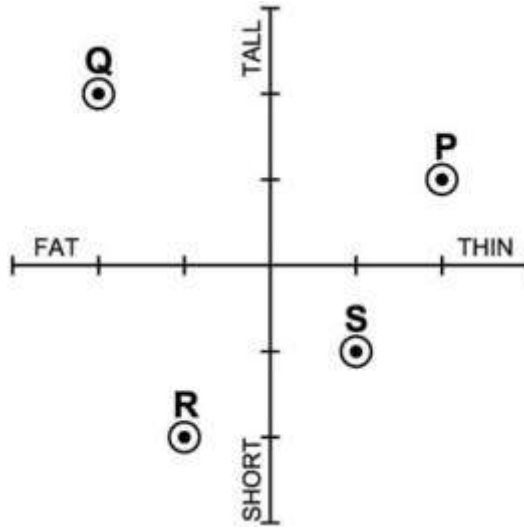
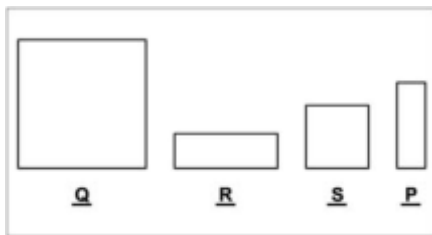
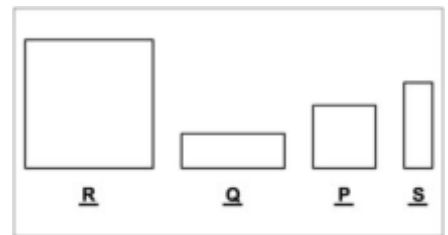

Figure X



(A)



(B)

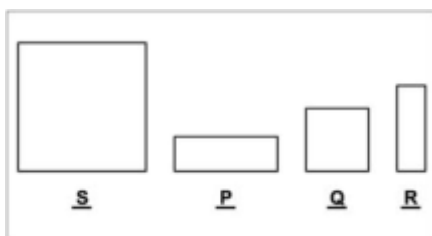

(C)

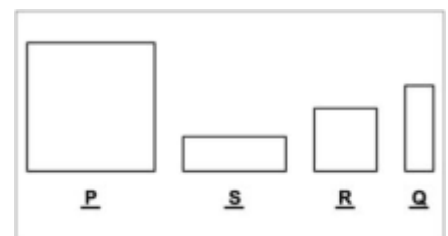

(D)

Q14. If the following profile is rotated along the given axis by 360 degrees,

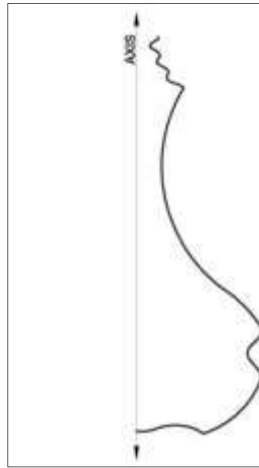

which of the following 3-dimensional form would be created?



(A)



(B)



(C)



(D)

Question Nos. 15 to 22 carry 2.0 marks each.

Q15. In the object given below, four different orientations are shown. Identify the pattern on the face with the “question mark(?)”.

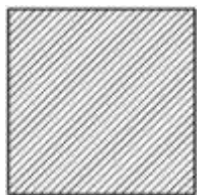
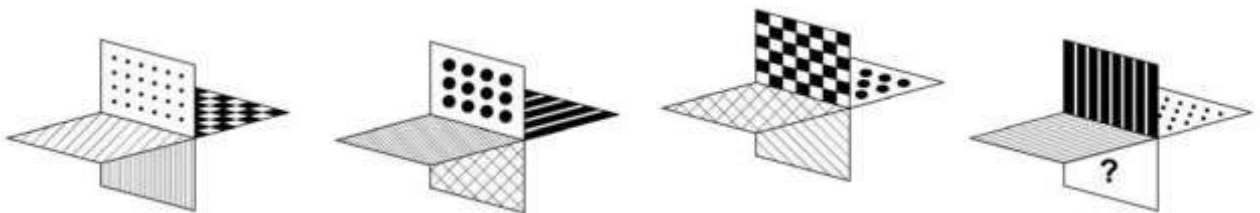

(A)

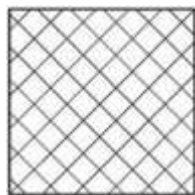

(B)

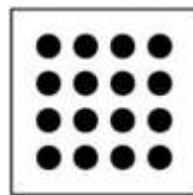

(C)

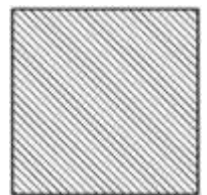

(D)

Q16. Four figures “R”, “S”, “T” and “U” are given below.

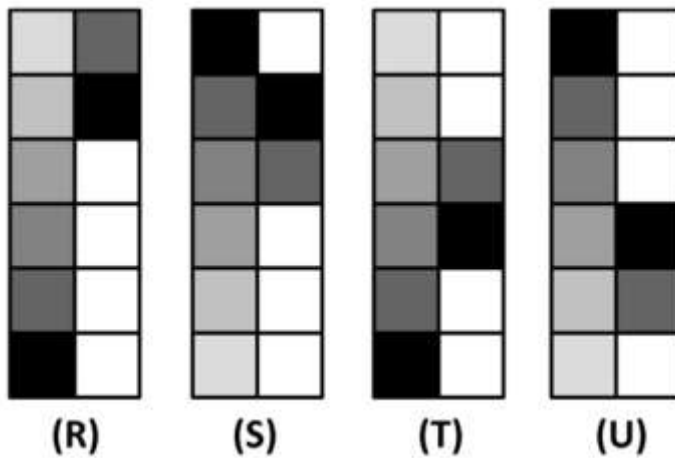

If figure “R” represents “ASC12”, figure “S” represents “DES23”, figure “T” represents “ASC34” and figure “U” represents “DES45”, then which of the following figures will represent “DES12”?

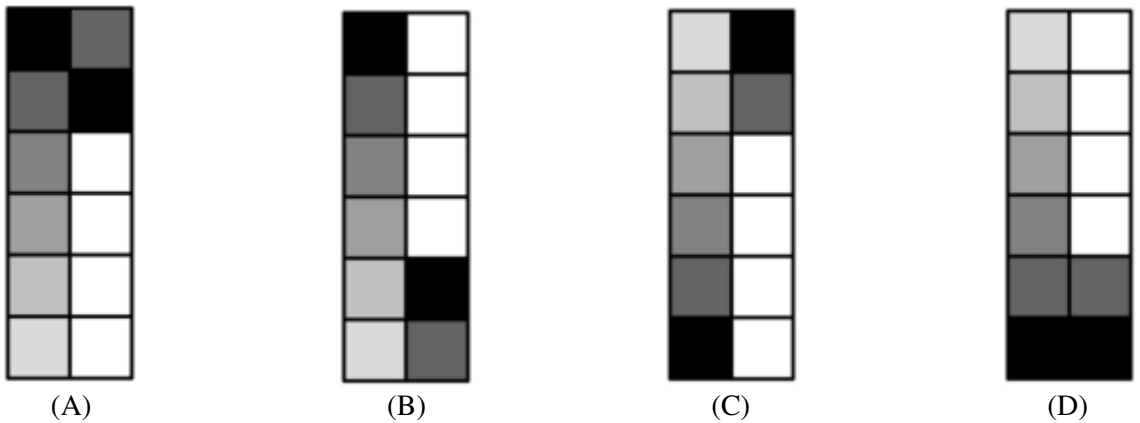

Q17. Observe the images below and indicate which two images are equal in surface area?

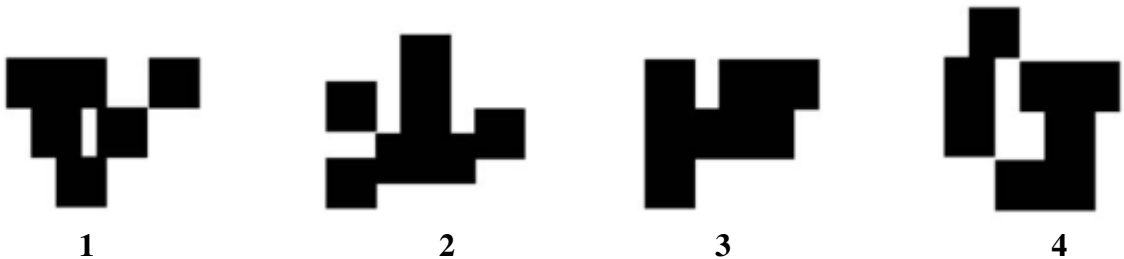

(A) 1 and 2
(C) 1 and 3

(B) 2 and 3
(D) 3 and 4

Q18. How many rectangles are there in the image given below?

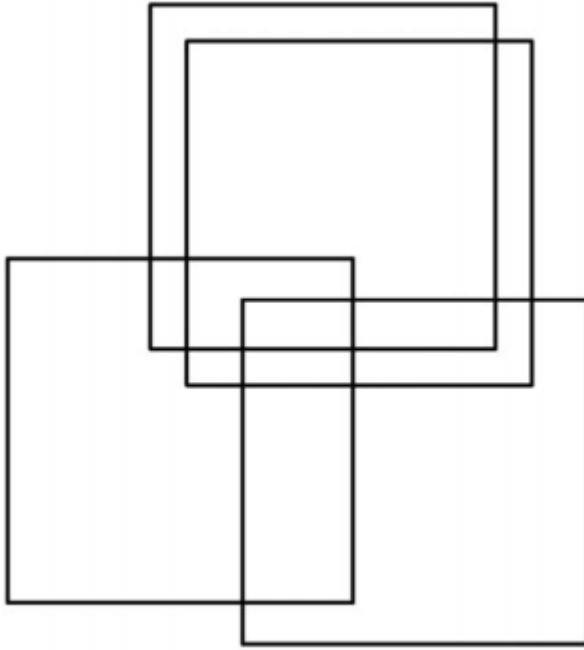

- (A) 15
- (C) 17

- (B) 21
- (D) 19

Q19. Identify the set of shapes which can lead to the following pattern using repetition and combination as a technique.

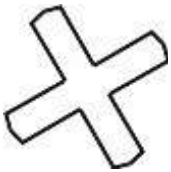
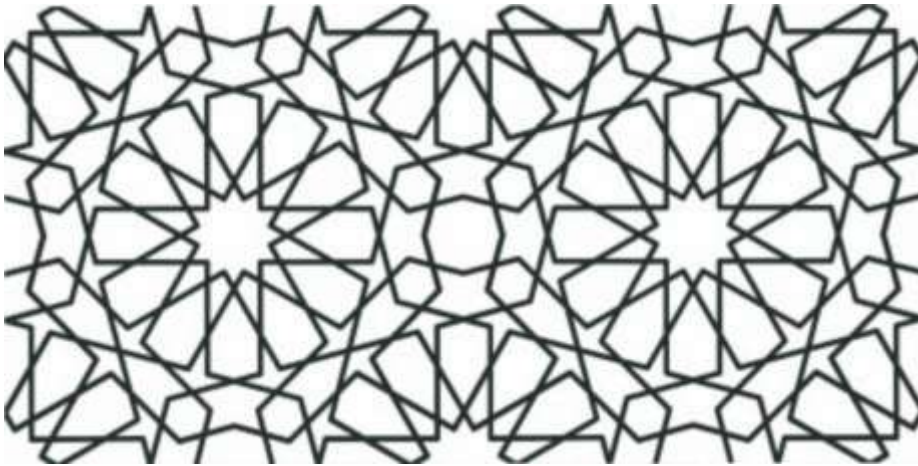

(i)



(ii)



(iii)



(iv)



(v)



(vi)

- (A) (iii) (iv) (v) (vi)
- (C) (i) (ii) (iii) (v)

- (B) (i) (iii) (v) (vi)
- (D) (ii) (iv) (v) (vi)

Q20. Which of the papers sets when folded along the intermediate borders can form the cube as given in the image below?

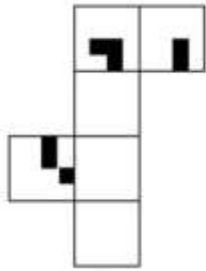
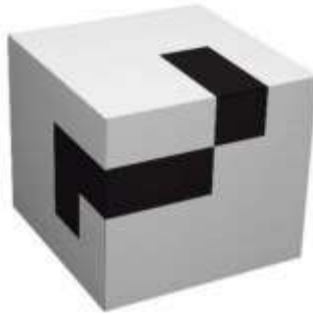

(A)

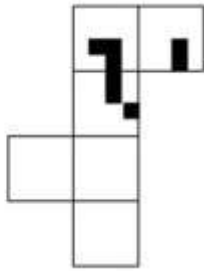

(B)

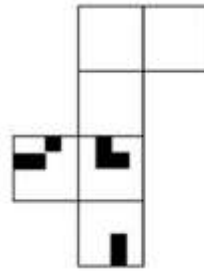

(C)

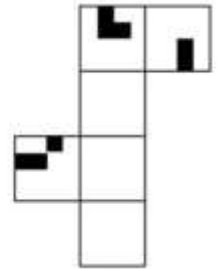

(D)

Q21. Observe the image given.

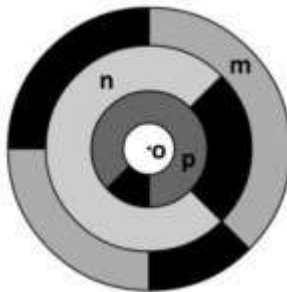

Please imagine the following process –

1. Rotate disc “m” 90 degrees clockwise around the center “o”
2. Rotate disc “n” 180 degrees counter-clockwise around the center “o”
3. Rotate disc “p” 180 degrees clockwise around the center “o”

What will the resultant figure look like?



(A)



(B)



(C)



(D)

Q22. Which of the following figures can be drawn, if you have to draw it without lifting your pencil and without drawing over the line(s) you have already drawn.

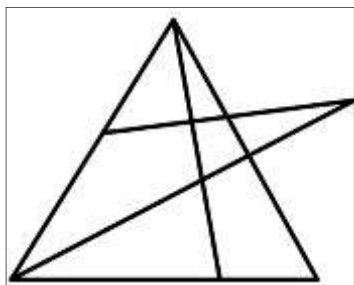

(A)

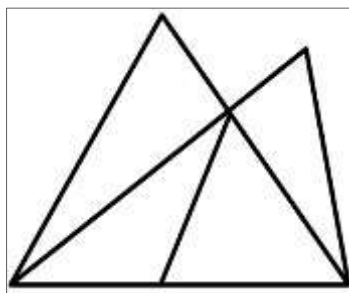

(B)

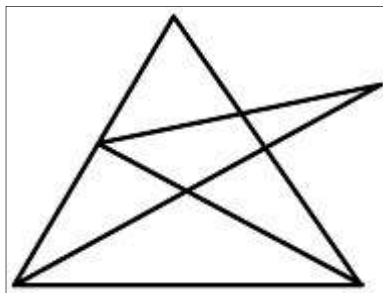

(C)

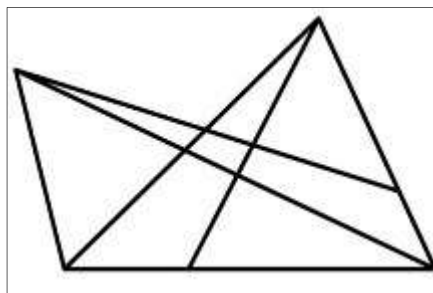

(D)

B.DES./GDPD DAT PRELIMS 2019 (PART I) ANSWER KEYS

Question No	Answers
1.	D
2.	D
3.	C
4.	A
5.	D
6.	C
7.	C
8.	C
9.	B
10.	A
11.	C
12.	C
13.	A
14.	B
15.	D
16.	A
17.	B
18.	***
19.	B
20.	B
21.	A
22.	C
*** 02 Marks awarded to all candidates.	



राष्ट्रीय डिजाइन संस्थान
NATIONAL INSTITUTE OF DESIGN

NID B.Des 2019 Original Paper Solved by NID Alumni

SILICA
YOUR DESIGN CAREER GUIDE

B.Des./GDPD

DAT Prelims 2019-20

Part II

Questions 23 to 26 are of subjective type. Do not write your name anywhere in the booklet.
This will lead to disqualification.

Q23. Observe the image of the scene as given below. A person tries to enter the room by a ladder from outside the window and sees the scene inside the room. Visualise and draw the scene from the person's point of view. No colour to be used. (15 marks)



THUMBNAILS-

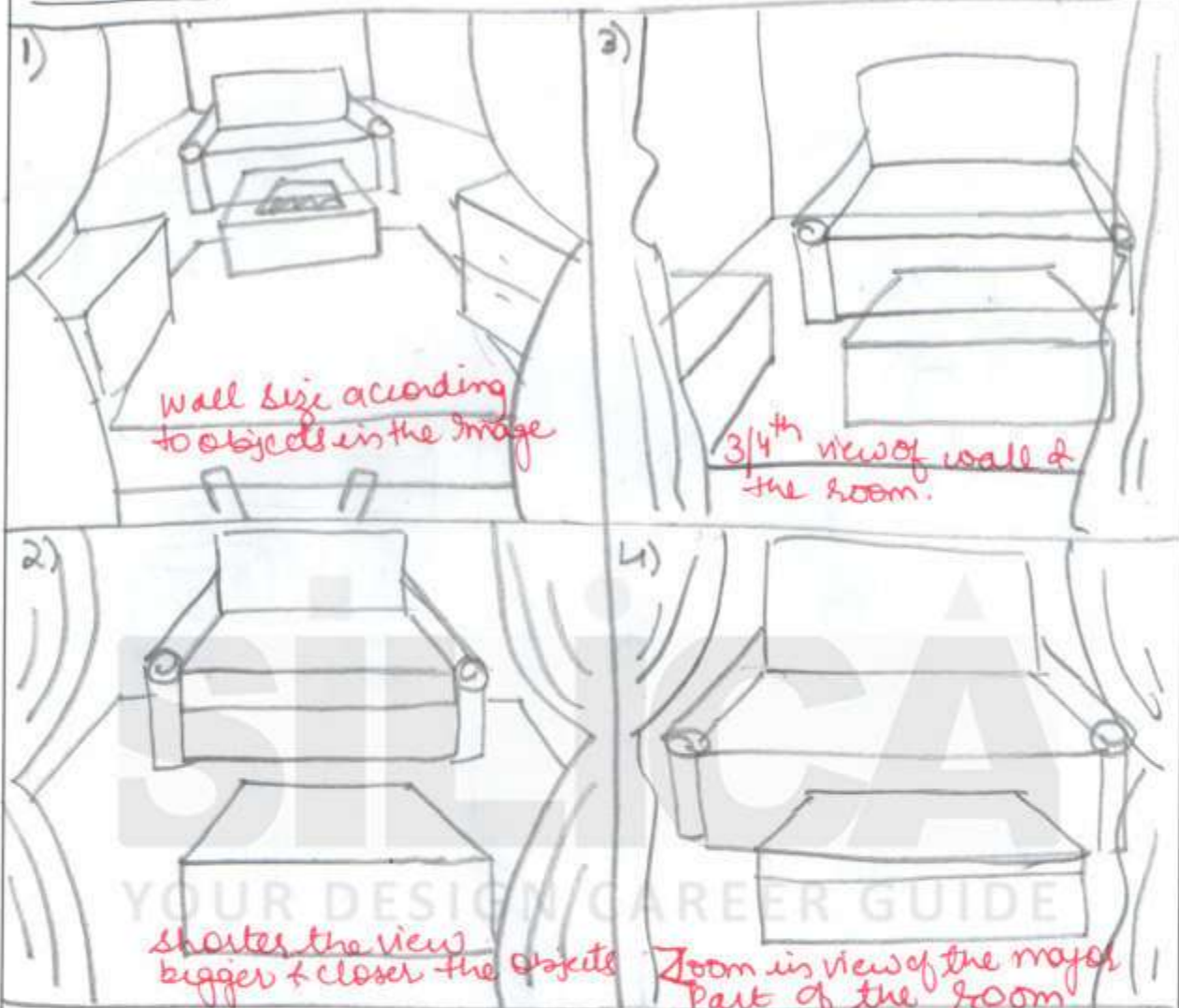

GUIDELINES-

- While sketching keep in mind about 1 point perspective view as the man entering is facing the front wall.
- Proportion & placement of objects in response to each other in the room should be the primary focus.
- Along with proportion, the alignment of human figure lying on the floor with objects.
- The visual should resemble the view given in question.
- Don't forget details (text, texture & pattern)

TIPS-

- Can use small wall & background to focus on objects.
- details & textures to be the main focus in foreground.
- Visualise yourself entering the room & that makes it easy to draw.
- Imagined point on the major elements first.
- Mark the objects according to proportion one by one.

FINAL WORK -

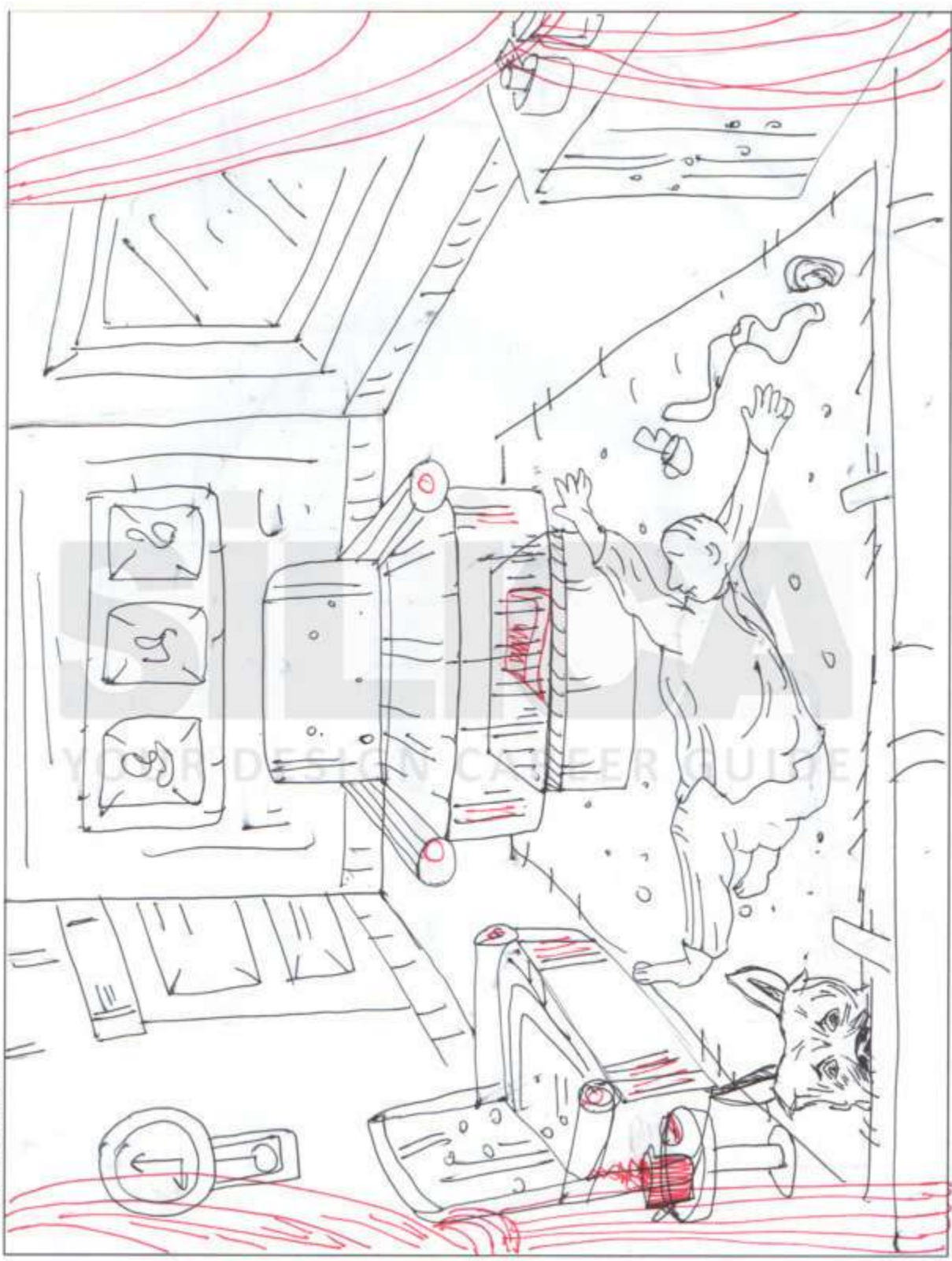

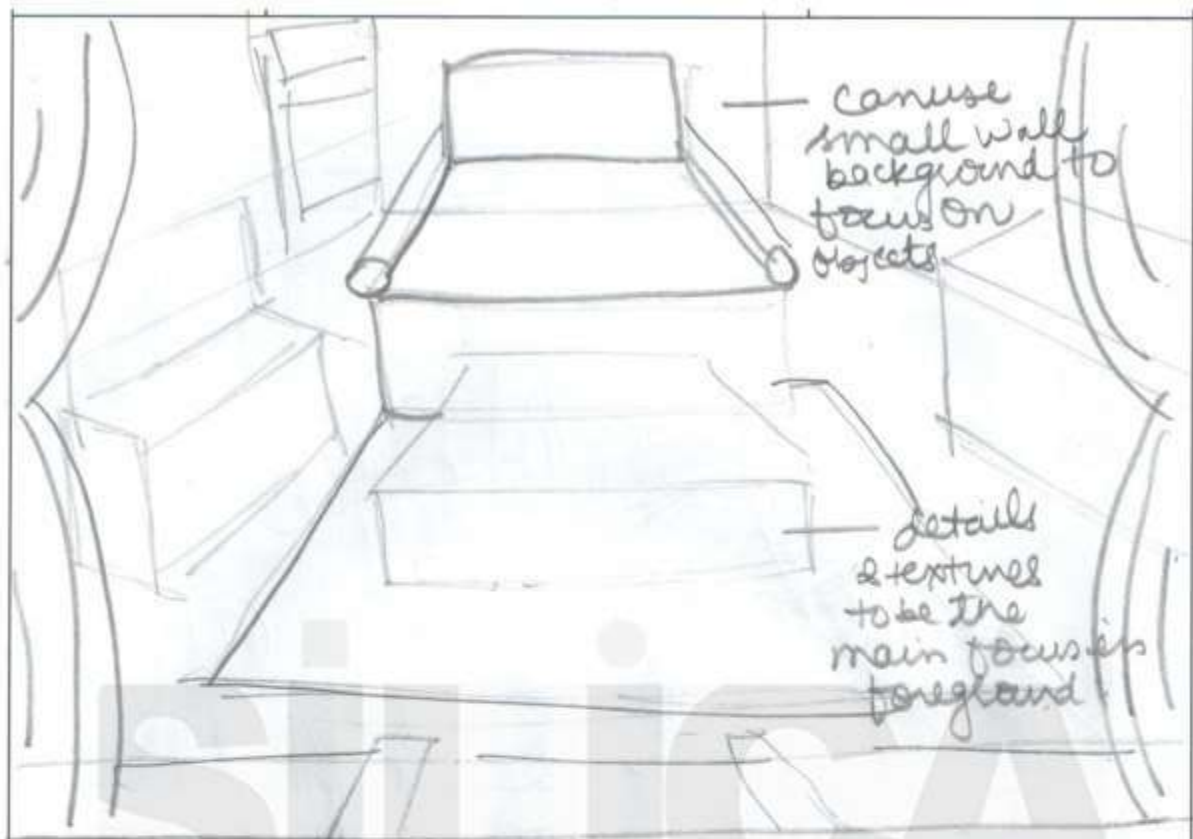

GUIDELINES -

- While sketching, keep in mind one point perspective view as the man entering is facing the front wall.
- Proportion of the objects & Placement in response to each other in the room should be primary focus.
- Along with proportion, the alignment of human figure lying on the floor & fallen objects on the floor.
- The visual should resemble the view given in the Question Paper.

P.S -

- Don't forget the details - (Text, Texture, Background)
- Major Details like curtains & floor while entering.

Q24. Imagine and draw a real life situation which represents "All that is gold does not glitter" in a meaningful way. Use the space given to draw and explain your interpretation in 5 lines. No colour to be used.

(20 marks)



It is true to say that "All that is gold does not glitter" - Here the rich is compared to gold (man with a car) But the real happiness to his son (running towards the balloon seller) is playing with balloons which is being sold by the old poor man. Always money/gold which shines bright can't buy happiness. Thus my artwork represents the two way society view.

Q25. To commemorate the 150th birth anniversary of Mahatma Gandhi, the Government of India has invited ideas to design a CIRCULAR postage stamp (Rs.20) from young minds. Depict your idea for the stamp in the given format. (you need to use colours). (15 marks)



Guidelines -

- Think of metaphors / images & relevant subject related to Gandhi ji.
- Add that subject in the background to make it as national stamp.
- Don't forget to add date / year & Anniversary details

Thumbnails -



150TH
GANDHI
JAYANTI



YOUR DESIGN CAREER GUIDE

TIPS -

- Mention the birth date & year
- celebrating the anniversary
- Date | Denomination
- Country name
- Tagline if Required
- most important is to use a unique visual for the stamp.

Q26. Visualise & draw the following as instructed. Do not use colour.

- A Draw a person sitting at a dining table with a plate, stainless steel spoon and fork laid out in front of him/her. (8 marks)



P.S - Using one point perspective is the scenario.

- B. An ant is sitting on the tip of a spoon handle. Draw the view of the table from the point of view of an ant. (6 marks)

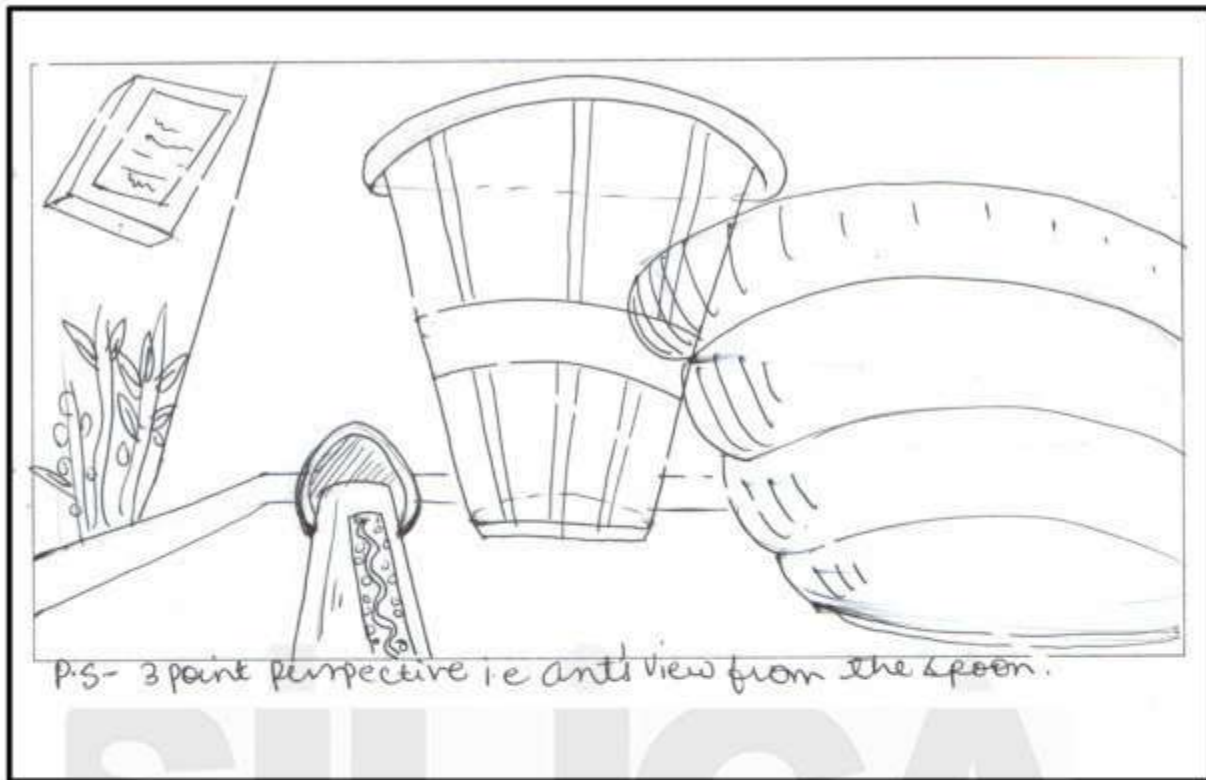

- C. Visualise and draw a stainless steel spoon and fork tied into a knot at their handles. (6 marks)

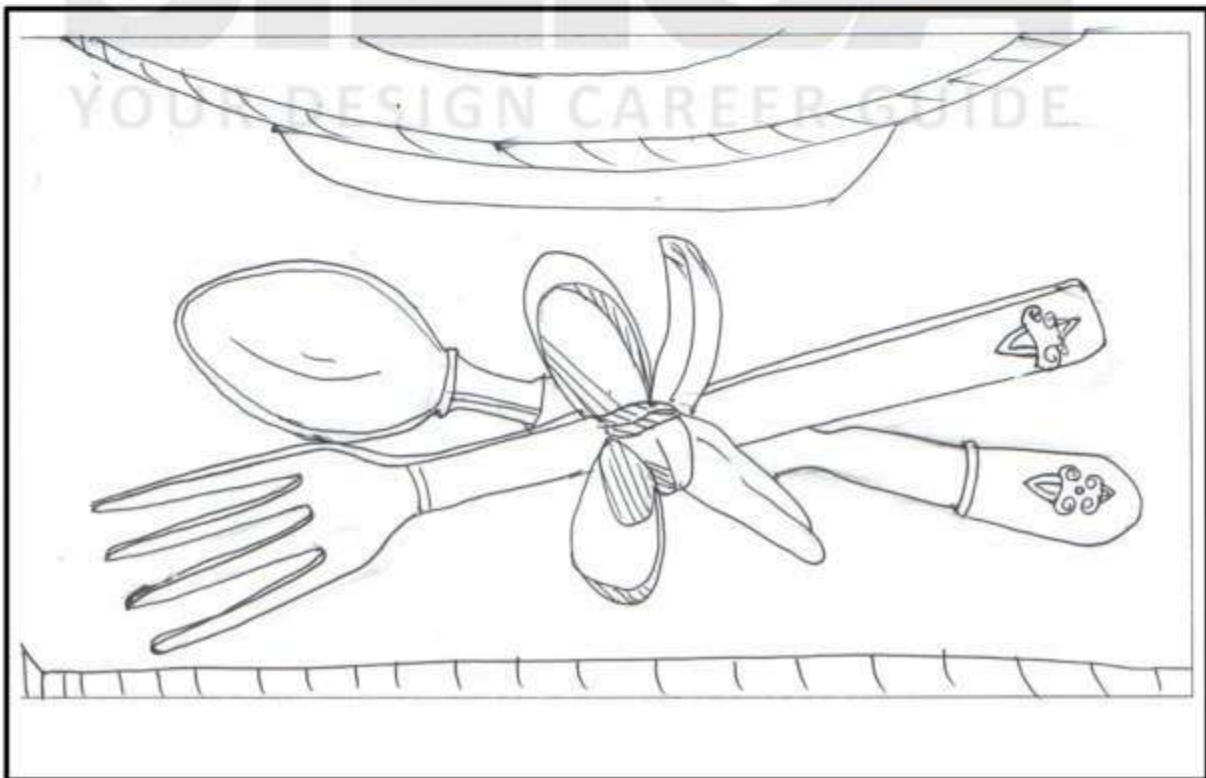

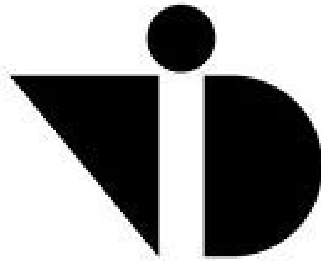

राष्ट्रीय डिजाइन संस्थान
NATIONAL INSTITUTE OF DESIGN

NID B.DES 2018

Original Paper

Solved From

SILICA
YOUR DESIGN CAREER GUIDE

BOOKLET CODE

31

(PART I)

QUESTION BOOKLET SERIES

D

Please fill in your Roll No.

--	--	--	--	--	--	--	--	--

NOTE : Confirm that the 1st and 2nd digits of your Roll No. are **3 1**. If not, bring it to the notice of the invigilator.

Name of candidate : _____ Signature of the candidate: _____

Part	Pattern	Question Nos.	Marks per Question	Marking of Answers	Exam Duration
I	Objective Type-Multiple Choice Questions	1 to 24	0.5	Answers of these questions are to be marked only on the OMR Answer Sheet which is provided separately, using Black/Blue ball point pen.	3 hours
		25 to 47	1.0		
		48 to 49	1.5		
		50 to 62	2.0		
		63 to 64	3.0		
II	Subjective Type	65	10.0	Answers of these questions are to be given in the space provided below each question on the Question-cum-Answer Booklet only.	
		66	14.0		
		67	6.0		

INSTRUCTIONS FOR CANDIDATES

1. **Please do not open this Question Booklet (Part I) until asked to do so.**
 2. Fill up the necessary information in the space provided on the cover of this Question Booklet (Part I), OMR Answer Sheet and Question-cum-Answer Booklet Part II before commencement of the test.
 3. The total duration of this test (Part I & Part II) is 3 hours. There are 64 questions in Part I and 3 questions in Part II.
 4. **The Test (Part I & Part II) is of total 100 marks.**
 5. **There is No Negative Marking.**
 6. You may attempt the questions in any order you prefer.
 7. Please check for the completeness of the Question Booklet (Part I) & Question-cum-Answer booklet (Part II) immediately after opening.
- 8. Q.Nos.1 to 64 are objective type questions and answers of these objective type questions are to be marked on OMR Answer sheet provided separately.**
- 8.1. Each question has four options marked (A) (B) (C) and (D).
 - 8.2. Choose the correct option and fill the oval completely with a Blue or Black Ball Point Pen only against the relevant question number.
 - 8.3. Use only **Blue or Black Ball Point Pen** to darken the oval for answering.
 - 8.4. Do not darken more than one oval against any question. No marks will be given for such responses.
 9. Rough work, if any, is to be done on the Question Booklet only. No separate sheet will be provided/used for rough work.
 10. Calculator, Mobile or any Electronic Gadgets, etc., are not permitted inside the examination hall.
 11. Candidates seeking, receiving and/or giving assistance during the test will be disqualified.
 12. Appropriate civil/criminal proceedings will be instituted against the candidates taking or attempting to take this Question Booklet or part of it outside the examination hall.
 13. The right to exclude any question(s) from final evaluation rests with the Examining authority.

QUESTION BOOKLET (PART I), OMR ANSWER SHEET AND QUESTION-CUM-ANSWER BOOKLET (PART II) ARE TO BE RETURNED ON COMPLETION OF THE EXAM.

PART-I

Questions 1 to 64 are multiple choice questions. The correct answer must be marked in the OMR answer sheet provided separately. Do not write your name anywhere in the booklet. This will lead to disqualification.

Directions (Question Nos. 1 to 24): Each question carries 0.5 marks. Please read the question carefully and select your response from the options provided.

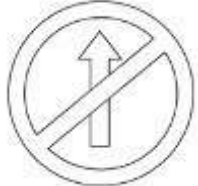
- Q1. Which one of the pairs given below is correctly matched?
(A) Harappan civilisation: Painted greyware
(B) The Mughals: Ajanta painting
(C) The Kushans: Gandhara school of art
(D) The Marathas: Pahari School of Painting
- Q2. Among the options given, in which of the following languages are the sacred scriptures of Buddhism written in?
(A) Prakrit (B) Pali
(C) Hebrew (D) None of these
- Q3. Kanyakumari, the tip of India is located towards which of the following?
(A) North of Tropic of Cancer (B) South of the Equator
(C) South of the Capricorn (D) North of the Equator
- Q4. Who won for India a silver medal in the Rio Olympics and in which sport?
(A) Sakshi Malik (Wrestling) (B) P V Sindhu (Badminton)
(C) Sania Mirza (Tennis) (D) Sakshi Malik (Badminton)
- Q5. The state of Emergency in India was of 21 months duration. When did this happen?
(A) 1975-1977 (B) 1973-1975
(C) 1977-1979 (D) None of these
- Q6. Choose the correct set of colours from given choices for the given Indian traffic sign.
(A) Red, Black, Green
(B) Red, Blue, Green
(C) Red, Black, White
(D) Red, Black, Blue
- 
- Q7. Match the following Materials with their respective Processes.
- | <u>Materials</u> | <u>Processes</u> |
|------------------|------------------|
| M1- Textile | P1- Blowing |
| M2- Stone | P2- Carving |
| M3- Metal | P3- Weaving |
| M4- Glass | P4- Casting |
- (A) M1- P3, M2- P2, M3- P4, M4- P1
(B) M1- P2, M2- P3, M3- P4, M4- P1
(C) M1- P3, M2- P1, M3- P4, M4- P2
(D) M1- P4, M2- P2, M3- P3, M4- P1

- Q8. Choose the correct option from given choices for matching the right pairs.
1-Spiral Binding; 2-Perfect Binding; 3-Wire-o Binding

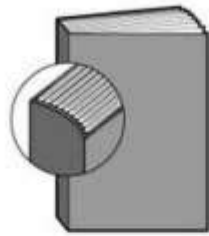

P



Q



R

- (A) P - 2, Q - 1, R - 3
(B) P - 3, Q - 2, R - 1
(C) P - 1, Q - 2, R - 3
(D) P - 2, Q - 3, R - 1
- Q9. Which artist painted the classic 'The Last Supper'?
(A) Leonardo da Vinci
(B) Michaelangelo
(C) Salvador Dali
(D) Pablo Picasso
- Q10. Which of the following refers to 'The Study of Insects'?
(A) Anthropology (B) Insectology (C) Entomology (D) Etymology
- Q11. The major part of agricultural land in India is under which kind of crop?
(A) Cash crops (B) Food crops (C) Oilseeds (D) Plantation crops
- Q12. The period of European history that lasted from the 14th to the 17th century is known as what?
(A) Renaissance (B) Industrial revolution
(C) Dadaism (D) None of these
- Q13. The closest descendant of Tyrannosaurus Rex that still lives today is



(A)



(B)



(C)

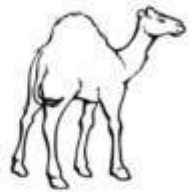

(D)

- Q14. 'Demography' is the statistical study of _____.
(A) Human behavior (B) Human settlement (C) Human life (D) Human populations
- Q15. Whose signature is seen on currency notes in India?
(A) Finance Minister (B) Mahatma Gandhi
(C) Finance secretary of state (D) Governor of RBI
- Q16. Identify the organization which uses the given logo.



- Q17. On which mechanism Paper Punching machine works?
 (A) Gear mechanism (B) Rack and Pinion mechanism
 (C) Spring mechanism (D) Four bar Mechanism
- Q18. The essential condition for the formation of shadow is,
 (A) there should be an opaque material.
 (B) there should be a source of light and screen.
 (C) the object must be placed in the path of light.
 (D) All of the above
- Q19. Which Indian River doesn't pass through any other neighboring country?
 (A) Sutlej (B) Jhelum (C) Narmada (D) Brahmaputra
- Q20. The 'Left' in politics refers to which of the following?
 (A) Progressive, radical groups (B) Conservative groups
 (C) Those sitting on the left in Parliament (D) None of these
- Q21. Which of these images depicts clockwise movement?

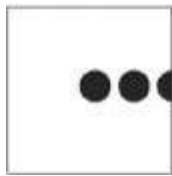

(A)

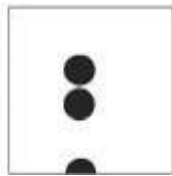

(B)

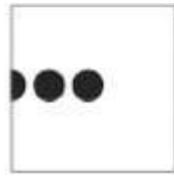

(C)

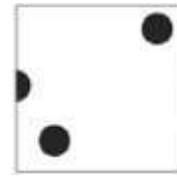

(D)

- Q22. Identify the visual which represents the correct relationship between chappals (flipflops), sandals, shoes and footwear.



(A)

(B)

(C)

(D)

- Q23. What will be warmer to wear in winters - one thick sweater or layers of thin sweaters?
 (The combined thickness of the thin sweaters is the same as one thick sweater.)
 (A) Both will be equally warm (B) One thick sweater will be warmer
 (C) Layers of thin sweaters will be warmer (D) Can't be said for sure
- Q24. 1. Gmail runs faster than Yahoo.
 2. Hotmail runs faster than Gmail.
 3. Yahoo runs faster than Hotmail.
 If the first two statements are true, the third statement is _____.
 (A) True (B) False (C) Uncertain (D) Can't Say

Directions (Question Nos. 25 to 47): Each question carries 1.0 marks. Please read the question carefully and select your response from the options provided.

Q25. You and your best friend are entering the stage for a dance performance from the same point, you both walk straight for 20 feet and turn left; then walk another 10 feet and turn left; again walk 10 feet, now you turn right and move 5 feet; while your friend turns left and moves 5 feet. Who is closer to the point from where you entered the stage?

- (A) You (B) Your Best friend (C) Both (D) Neither

Q26. Fact 1: Rashmi said, "Jyoti and I both have dogs."

Fact 2: Jyoti said, "I don't have a dog."

Fact 3: Rashmi always tells the truth, but Jyoti sometimes lies.

Which of the following statements must also be a fact?

Statement I: Jyoti has a dog. Statement II: Rashmi has a dog. Statement III: Jyoti is lying.

- (A) All the statements are facts. (B) Statement II Only
(C) Statement I & II Only (D) Statement I Only

Q27. Pointing to a man in a sketch, a woman said, "His brother's father is the only son of my grandfather." How is the woman related to the man in the sketch?

- (A) Mother (B) Sister (C) Aunt (D) Daughter

Q28. In the given figure, how many triangles are there in total?

- (A) 5
(B) 8
(C) 10
(D) 12



Q29. If it takes 5 machines 5 minutes each to make 5 laddoos, how long would it take 100 machines to make 100 laddoos?

- (A) 5 (B) 20 (C) 100 (D) 25

Q30. Out of the 26 English alphabets, how many 'capital' alphabets can be made using straight lines only?

- (A) 13 (B) 15 (C) 16 (D) 17

Q31. Select the correct image of the given figure, as it will appear reflected in water.



(A)



(B)



(C)



(D)

Directions (Question Nos. 32 to 35): Study the given images carefully to answer these questions.



Q32. Which one of the above images best represents, “I want to live long”?

Q33. Which one of the above images best represents, “I don’t want to carry extra baggage”?

Q34. Which one of the above images best represents, “I am comfortable with who I am”?

Q35. Which one of the above images best represents, “I want to be the best”?

Directions (Question Nos. 36 to 39): Study the given images carefully to answer these questions.

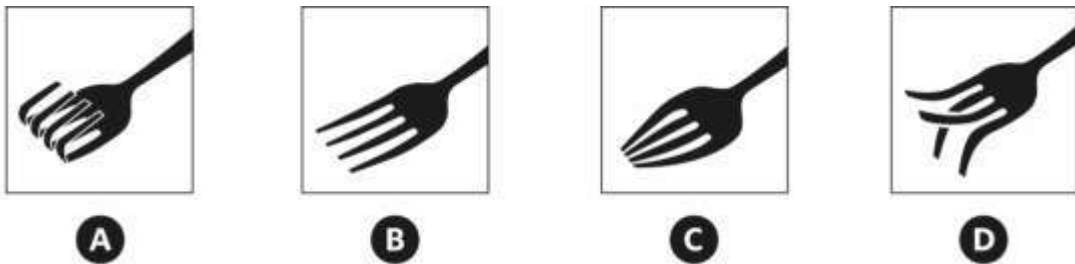

Q36. Which one of the above images best represents, “Sincere”?

Q37. Which one of the above images best represents, “Indifferent”?

Q38. Which one of the above images best represents, “Dramatic”?

Q39. Which one of the above images best represents, “Selfish”?

Q40. Population of a village increases by 10% per year. Find the total population after 3 years if present population is 1000.

- (A) 1300 (B) 1301 (C) 1331 (D) 1030

Q41. Mr "X" and Mr "Y" are good friends. Mr "X" borrows ₹2 lakhs (without any interest) from Mr "Y" and agrees to pay back 'Half' of the 'outstanding amount' every year. How many years Mr "X" takes to pay back the entire money ?

- (A) Sixteen Years (B) Thirty Two Years (C) Sixty Four Years (D) None of these

Directions (Question Nos. 42 to 43): Study the given images carefully to answer these questions.

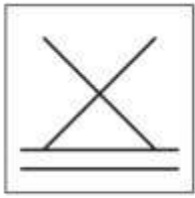

A

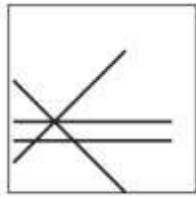

B

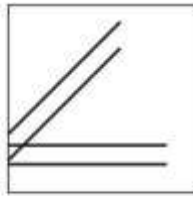

C

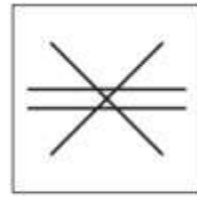

D

Q42. Which one of the above images best represents, “stability”?

Q43. Which one of the above images best represents, “symmetry”?

Q44. The given sheet of transparent square paper with the patterns is folded twice. What will be the resultant pattern?

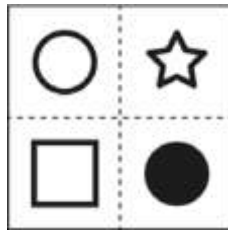

A



B



C



D

Q45. If the earth took 365 days to spin once about its own axis (as opposed to one day), then the consequence of this would be that,

(A) there would be no seasons.

(B) one half of the earth would be in permanent darkness and the other in permanent daylight.

(C) days and nights would be of equal length at all places on earth at all times.

(D) the sun would be overhead everywhere on earth.

Q46. Identify the missing figure.



(1)



(2)



(3)

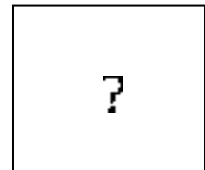

(4)



(A)



(B)



(C)



(D)

Q47. Based on the set-up given below, identify the correct shadow which will fall on the screen.

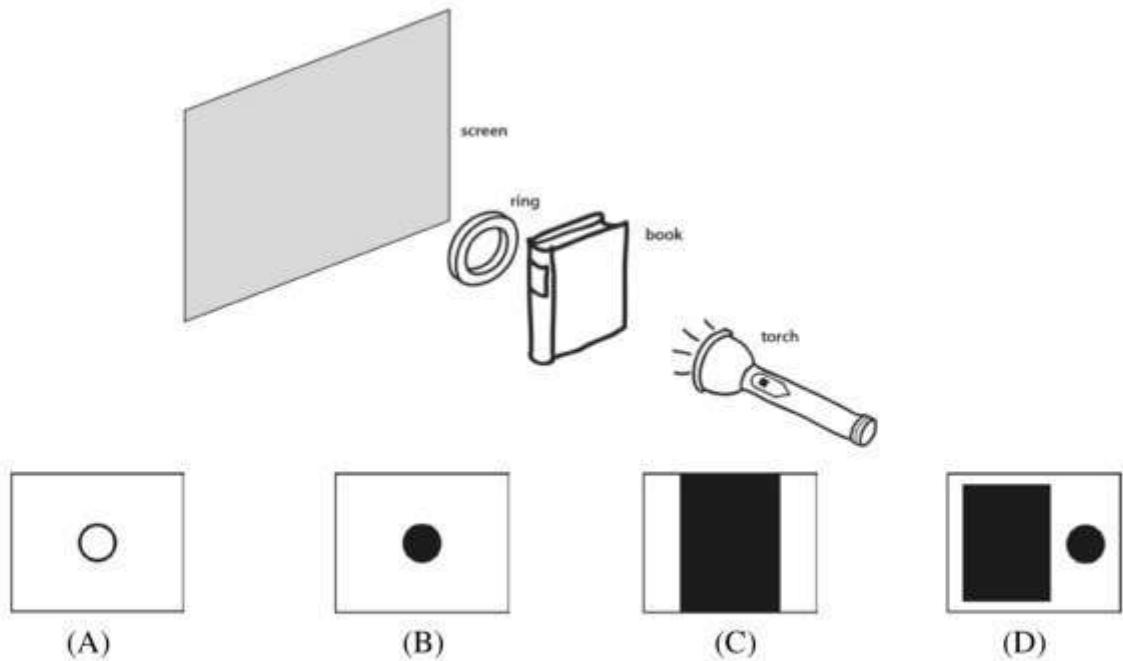

Directions (Question Nos. 48 to 49): Each question carries 1.5 marks. Please read the question carefully and select your response from the options provided.

Q48. *The cleaning and restoration of Michaelangelo's frescoes on the ceiling of the Sistine Chapel were undertaken by some of the world's finest art restorers under the close supervision of an international team of art experts and historians. Nonetheless, the results have produced a storm of controversy. Most modern viewers, it seems, had become accustomed to seeing the frescoes with their colours dulled by layers of yellowing glue and varnish and with the contours of the figures obscured by centuries' accumulation of grime.*

The passage implies that Michaelangelo's frescoes

- (A) have been the subject of intense controversy over their artistic merit.
 - (B) suffered until recently from centuries of obscurity and neglect.
 - (C) have been obscured by dirt during the recent process of restoration.
 - (D) were originally much brighter and more vivid than most modern viewers realize.
- Q49. *"So when we see 'Red", what we are actually seeing is that portion of the electromagnetic spectrum with a wavelength of about 0.0007 millimeters, in a situation where the other wavelengths are absent. It is our brains (and our language) which inform us it is "red", and at the same time they often attach cultural labels that tell us it is powerful, or that it is the colour of love, or that it is a traffic sign which means we have to stop".*

Of all the inferences that we can make from this narration which is the most untrue?

- (A) Electromagnetic waves of wavelength of about 0.0007 millimeters, come and hit our eyes when we are in front of a Traffic light with the red light glowing.
- (B) When we see a painting with many colours - blue, green, red, yellow, etc. electromagnetic waves of many wavelengths are coming and hitting us.
- (C) When we see the colour red, we call it 'red' as our language defines the portion of the electromagnetic spectrum with a wavelength of about 0.0007 millimeters as 'red'.
- (D) The 'red' colour is so powerful because of the electromagnetic wave of wavelength of 0.0007 mm that the colour comes from.

Directions (Question Nos. 50 to 62): Each question carries 2.0 marks. Please read the question carefully and select your response from the options provided.

Q50. In the given figure, if 'S' represents Sea, 'B' represents Bhopal, 'C' represents Chennai, then what does 'X' represent?

- (A) Pune
- (B) Bhubaneshwar
- (C) Hyderabad
- (D) Raipur

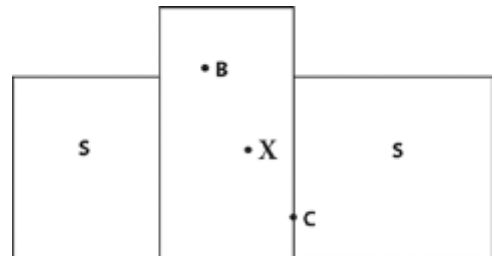

Q51. Which of the following options has the closest resemblance to the given image?

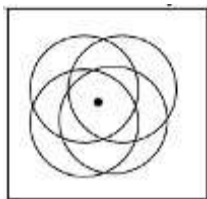
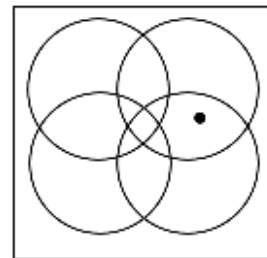

(A)

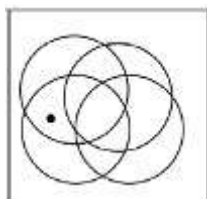

(B)

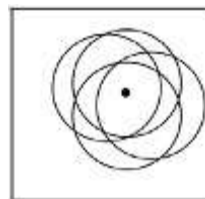

(C)

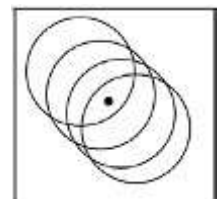

(D)

Q52. If the sun were a cube instead of a sphere, in what possible shapes could you see it in the sky?



Directions (Question Nos. 53 to 55): Read the paragraph carefully to answer these questions.

Culture gives meaning to our relationship with the other, as it also forms our subjective identity. Culture, therefore, enters into the processes of social change in many forms and at various levels. It defines the quality of social change as its indicator. Anthropologists define culture as the set of learned behaviours, beliefs, attitudes, values, and ideals that are quintessential to a particular society. The defining features of culture are that it is commonly shared; it is learned; it is mostly integrated (we mean that the elements or traits that make up that culture are just a random assortment of customs but are mostly consistent with one another); and culture is always changing. This definition includes such products of group life as folklore, mores, and other group expectations. In addition, there are the material elements that comprise so important a part of our contemporary culture and supplement the

psychological elements at every point. Finally, there are the meaningful relationships between the various parts of culture and the symbolic interpretations placed upon them. Customs, material objects, and meaningful relationships thus comprise the principal aspects of culture. Culture includes both structure and function. Because of its symbolic character,...culture is easily transmitted from one person to another. In this way, culture is a continuous and growing whole, acquiring new elements as it is handed down from one generation to the next, and spreading to new groups and peoples. The history of culture is, in a real sense, the history of humankind. For hundreds of thousands of years, culture in some form has been continuously transmitted. Some elements have been lost, others have been changed, new ones have been added. But culture itself has gone on.

Ideas are the real foundations of culture. All the machines in the world would be useless without the knowledge of how to use them. Human beings are, furthermore, a symbol-using animal, who make an understanding of these symbols fundamental to an understanding of culture. The meanings attached to the different aspects of culture are more important than the physical form these aspects may take. Material objects are clearly the product of humankind's cultural activity. No one would presume that the automobile for example sprang full blown from the brain of some supernatural power. The automobile is the product of a long line of human inventors, each of whom added something to the finished product. It must have started with the invention of the wheel.

- Q53. Which of the following cannot be inferred from the passage?
 (A) The transmission of material culture over time has led to several inventions across the world.
 (B) The symbolic dimension of culture leads to its continual transmission over time.
 (C) Culture plays a key role in how society changes over time.
 (D) Culture and society are often at odds with each other.
- Q54. Which of the following would be the best substitute for the term 'quintessential' in the passage?
 (A) Quaint (B) Typical (C) Unmatched (D) Inadequate
- Q55. The writer uses the phrase, 'ideas are the real foundations of a culture' in the passage to refer to the fact that
 (A) without the intellectual stimulus, material objects are meaningless.
 (B) ideas are based on culture.
 (C) symbols are the result of humankind's material activity.
 (D) culture is something solid and stable.
- Q56. Pappu's mummy leaves home for office at 8:05 am and returns home at 11:15 pm. In this period how many times would Pappu see the minute and hour hands of their clock line up along a straight line?
 (A) 30 (B) 15 (C) 14 (D) 28
- Q57. Which option indicates the correct sequence in which the following words appear in a Dictionary?
 1) decease 2) decelerate 3) decentralize 4) deceased
 5) deceive 6) december 7) deception
 (A) 1, 2, 3, 4, 5, 6, 7 (B) 1, 3, 5, 2, 4, 6, 7
 (C) 2, 4, 6, 1, 3, 5, 7 (D) 1, 4, 5, 2, 6, 3, 7

Q58. The shape below is formed from three smaller pieces. These pieces are connected by a tiny hinge at their point of attachment. Suppose, you were able to rotate the pieces so that neighboring sides aligned flatly and squarely, they will come together to form which of the following shapes?

- (A) Square
- (B) Rectangle
- (C) Triangle
- (D) Trapezium



Q59. Aman was playing with his building blocks. He made a structure, three views of which are given. So, how many blocks did Aman use eventually?

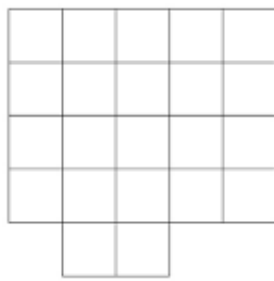

Top View

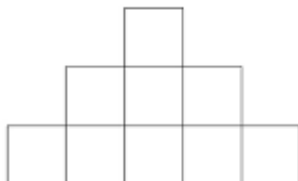

Front view

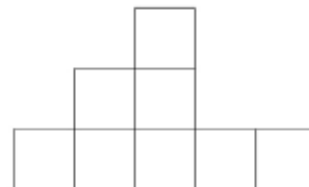

Side view

- (A) 28
- (B) 26
- (C) 27
- (D) 29

Directions (Question Nos. 60 to 62): Read the paragraph carefully to answer these questions.

Colour is one of the most obvious visual feature of a gem. But in fact, it is just one of many properties, all of which are dependent upon light. The individual crystalline structure of a gemstone interacts with light in a unique way and determines the optical properties of each gem species. Effects produced by light passing through a gem and also produced by the reflection of light are discussed here. The colour of a gem depends largely on the way it absorbs light. White light is made up of the spectral colours of the rainbow, and when it strikes a gem some spectral colours are "preferentially absorbed". Those that are not absorbed, pass through or are reflected back, giving the gem its colour. Each gem, in fact has a unique colour "fingerprint", but this is only visible when viewed with a spectroscope. To the naked eye, many gems look the same colour.

Allochromatic or other-coloured gems are coloured by trace elements or other impurities that are not an essential part of their chemical composition. Corundum, for example, is colourless when pure but impurities in it (like metal oxide) create the red stones we know as rubies, blue, green and yellow sapphires, and orange-pink padparadscha. Allochromatic gems are often susceptible to colour enhancement or change.

Q60. What is a gemstone's unique characteristic?

- (A) Its transparency
- (B) Its absorption spectrum
- (C) Its reflection
- (D) None

Q61. What cannot be called allochromatic?

- (A) Stone with metal oxide
- (B) Orange-pink padparadscha
- (C) Pure corundum
- (D) None

Q62. What subject of study/science stream is being discussed here?

- (A) Gemology
- (B) Colour therapy
- (C) Astrology
- (D) Spectrology

Directions (Question Nos. 63 to 64): Each question carries 3.0 marks. Please read the question carefully and select your response from the options provided.

Q63. Which of the following shapes can fill the given figure without any gaps?

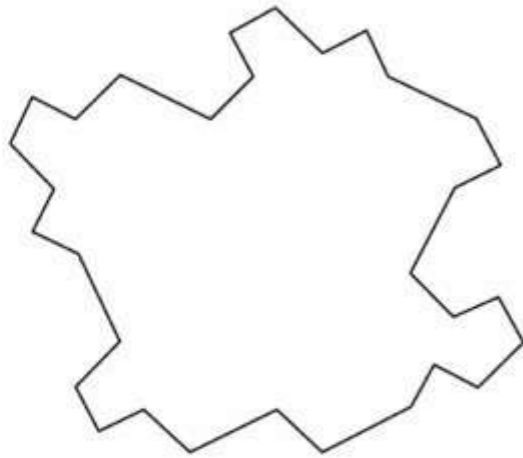

(A)



(B)



(C)



(D)

Q64. Look at the given figure which has 16 squares. Now if –

- (1) Square “a” moves two blocks right
- (2) Square “b” moves one block left
- (3) Square “c” moves one block up
- (4) Square “d” moves one block right and
- (5) The resultant figure is flipped about its vertical axis.

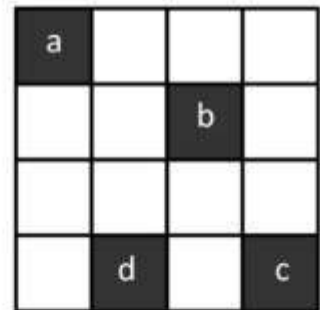

Which one of the following will be the final figure?

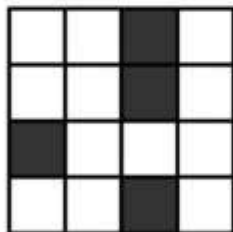

(A)

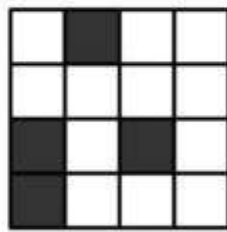

(B)

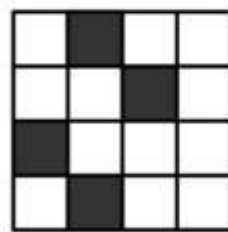

(C)

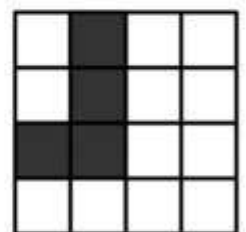

(D)

BOOKLET CODE 31
PART - 1

QUESTION BOOKLET SERIES (D)
ANSWER KEYS

Q.No.	Correct Answer	Marks	Q.No.	Correct Answer	Marks
1	C	0.5 marks			
2	B	0.5 marks	35	A	A=1.0 marks B=0.5 marks D=0.5 marks
3	D	0.5 marks	36	B	B=1.0 marks C=0.5 marks
4	B	0.5 marks	37	C	C=1.0 marks B=0.5 marks
5	A	0.5 marks	38	D	D=1.0 marks A=0.5 marks
6	C	0.5 marks	39	A	A=1.0 marks C=0.5 marks
7	A	0.5 marks	40	C	1.0 marks
8	A	0.5 marks	41	D	1.0 marks
9	A	0.5 marks	42	A	1.0 marks
10	B	0.5 marks	43	D	1.0 marks
	C	0.5 marks	44	A	1.0 marks
11	B	0.5 marks	45	B	1.0 marks
12	A	0.5 marks	46	A	1.0 marks
13	B	0.5 marks	47	C	1.0 marks
14	D	0.5 marks	48	B	1.5 marks
15	D	0.5 marks		D	1.5 marks
16	A	0.5 marks	49	D	1.5 marks
17	C	0.5 marks	50	C	2.0 marks
18	D	0.5 marks	51	B	2.0 marks
19	C	0.5 marks	52	B	2.0 marks
20	A	0.5 marks	53	D	2.0 marks
21	D	0.5 marks	54	B	2.0 marks
22	A	0.5 marks	55	A	2.0 marks
23	C	0.5 marks	56	D	2.0 marks
24	B	0.5 marks	57	D	2.0 marks
25	B	1.0 marks	58	C	2.0 marks
26	A	1.0 marks		A	2.0 marks
27	B	1.0 marks	59	B	2.0 marks
28	C	1.0 marks		C	2.0 marks
29	A	1.0 marks		D	2.0 marks
30	B	1.0 marks	60	D	2.0 marks
31	B	1.0 marks	61	C	2.0 marks
		D=1.0 marks	62	A	2.0 marks
32	D	B=0.5 marks A=0.5 marks	63	A	3.0 marks
		B=1.0 marks C=0.5 marks A=0.5 marks	64	C	3.0 marks
33	B	C=1.0 marks B=0.5 marks A=0.5 marks			
34	C	A=0.5 marks			

Option not mentioned above against Q.No. is incorrect answer and carries "0" (zero) marks.





राष्ट्रीय डिजाइन संस्थान
NATIONAL INSTITUTE OF DESIGN

NID B.Des 2018 Original Paper Solved by NID Alumni

SILICA
YOUR DESIGN CAREER GUIDE

PART-II

Directions: Please read the questions carefully and answer in the space provided.

Q65. Given here is the silhouette of a few objects in a specific position with respect to each other.

Imagine that the three objects are made of a) transparent glass, b) paper and c) wood respectively. In the given space below, draw the same arrangement of all the three objects without changing their relative position. Your drawing should be as large size as possible in the given space. Use shading to render material on the objects, such that the source of light is from the top right corner.

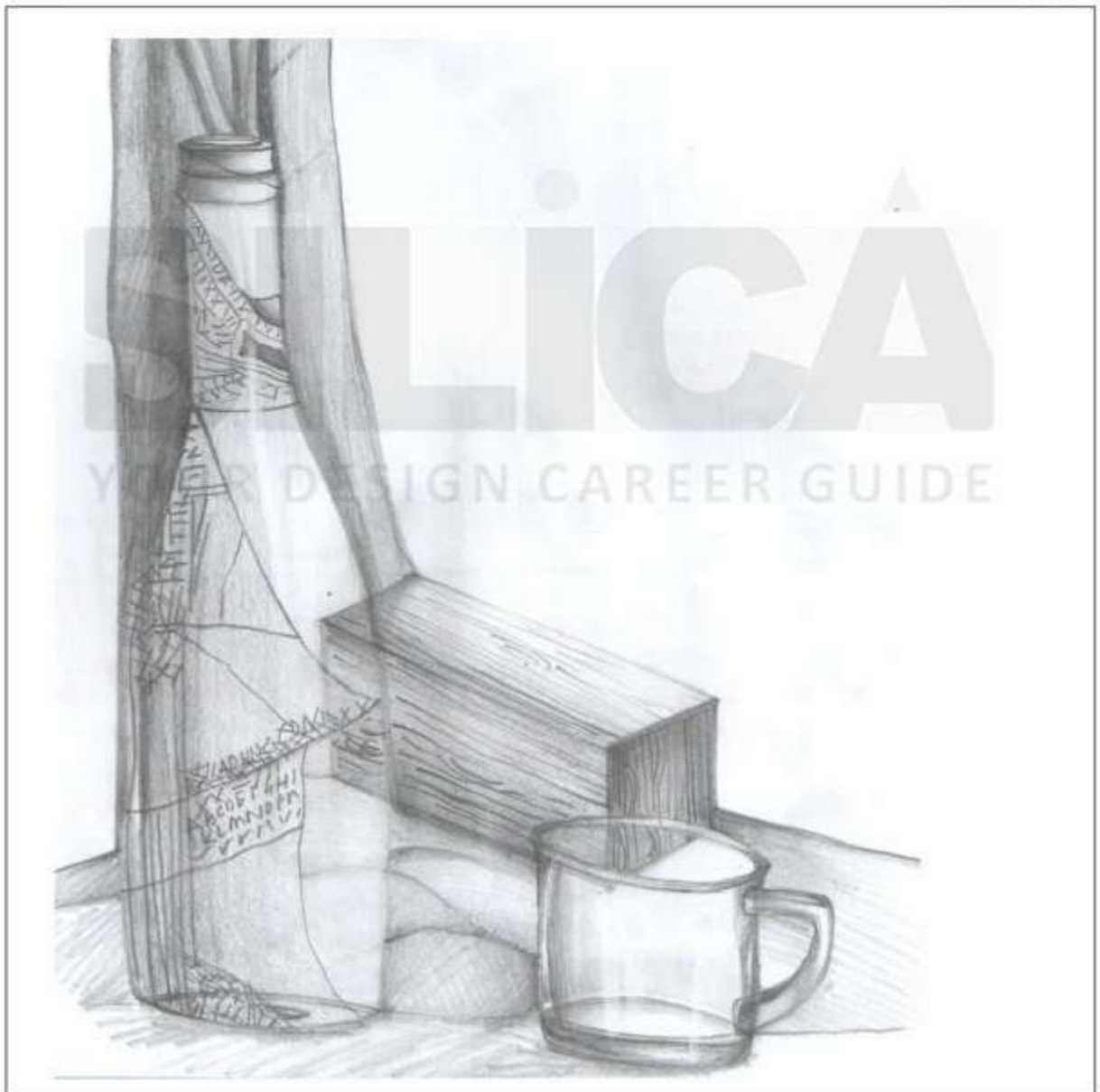

Thumbnails -



Identify Placement of objects & its proportions



Can use left hand space for objects & right for Background and Light source



Can use left hand space for objects & right for Background and Light source



GUIDELINES -

- Identify the central space & draw the objects so that the source of light can be easily seen.
- Shade with 8B pencil for better gradation & textures
- Don't forget Breathing space to leave from all the sides.

TIPS -

- Mark the area first before drawing.
- Identify the major object first (i.e. cup & bottle).
- Use Paper texture in Bottle, easily rendered.
- Give Background & Foreground.

Q66. During a mishap due to short-circuit in the wiring of a multi story building, there was a fire on the ground floor near the staircase, which was spreading fast. A middle aged mother with her two children aged 4 and 7 were trapped in the balcony of the first floor. Neighbours of the society could find only a scooter, a 5 feet. tall ladder and some nylon rope of 12 feet. Depict the scenes showing how would the neighbours rescue the group and bring them down in the respective spaces provided. Do not use colour.

A) Rescuing the mother



B) Rescuing the children



P.S - Using 1pt perspective for frontal & zoom in view.

Q67. "Ajay loved spending time gardening with his grandmother when he was a child. He remembers, once when he was 8 years old, by mistake he planted a seed of Corn along with a seed of Pea. Next morning when he went to the spot what he saw there was simply beyond his imagination. He still has the drawing of what grew on that spot. He felt amazed looking at the drawing of what he saw and wondered whether it was just his imagination or it actually happened."

Draw the drawing mentioned in the above paragraph.
Use pencil or pen to draw. Shading or coloring is not required.

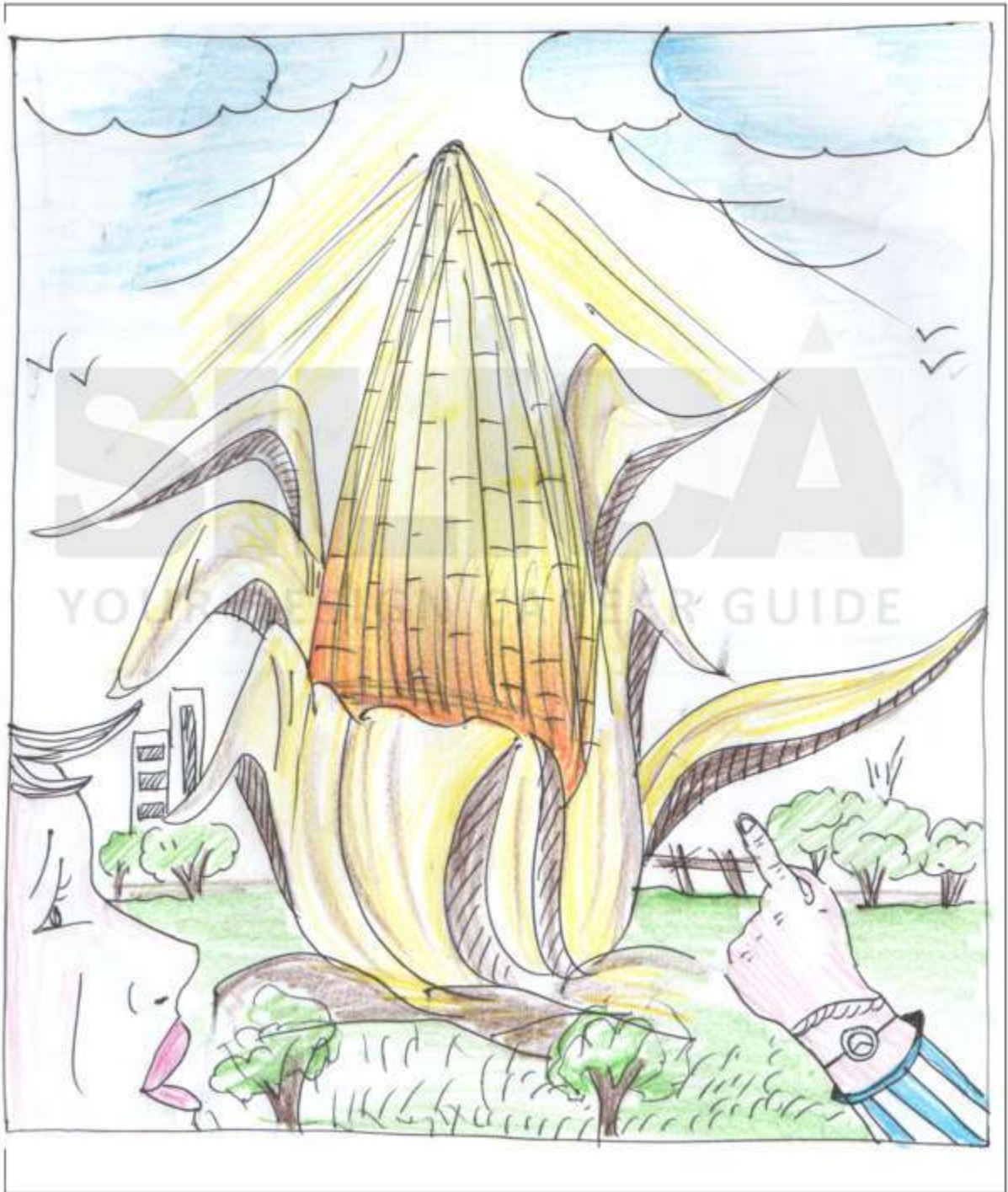

Thumbnails -

Garden - Scene 1



Character - Scene 2



Character - Scene 3



Scene 4 Surprise



GUIDELINES -

- Draw & visualise the characters & the scenarios in thumb nails.
- Imagine & create a plot of story in your mind.
- Once you have decided the end of the story, it is easy to create a scene with a climax.

TIPS -

- Draw scene by scene & step by step.
- Exaggeration sometimes can work easily.
- Easy to manipulate scenario with one main character of the story.

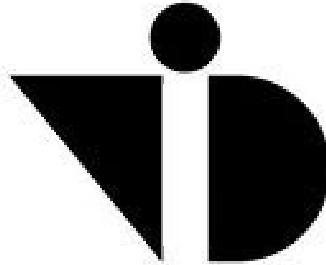

राष्ट्रीय डिजाइन संस्थान
NATIONAL INSTITUTE OF DESIGN

NID B.DES 2017 Original Paper Solved From

SILICA
YOUR DESIGN CAREER GUIDE

PART-I

Questions 1 to 75 are multiple choice questions. The correct answer must be marked in the OMR answer sheet provided separately. Do not write your name anywhere in the booklet. This may lead to disqualification.

Directions: Question numbers 1 to 26 carry 0.5 marks each. Read the questions carefully and select your response from the options provided.

- Q1. Which colour of a flame represents the highest temperature?
(A) Blood Red (B) Deep Blue
(C) Golden Yellow (D) White

- Q2. Which one of the following is this image associated with?
(A) Unified Sequential Buffer
(B) Universal Serial Buffer
(C) Universal Serial Bus
(D) Unicode Sequential Bus



- Q3. Which of the following is not yet a UNESCO World Heritage Site in India?
(A) Great Living Chola Temples, Tanjavur, Tamil Nadu
(B) Sunderban National Park, West Bengal
(C) River Island of Majuli, Midstream of Brahmaputra, Assam
(D) Virupaksha Temple, Hampi, Karnataka

- Q4. What would be the best choice for a window to keep the outside heat away?
(A) Single-pane glass.
(B) Double-pane glass without a gap in between.
(C) Double-pane glass with water filled in between.
(D) Double-pane glass with air in between.

- Q5. Identify the organization which uses the given symbol.
(A) Panda Rescue Initiative
(B) Forest Research Institute
(C) World Wide Fund for Nature
(D) People for Ethical Treatment of Animals



- Q6. Which of the following is the correct breathing pattern?
(A) As you breathe in, the chest expands first and then the stomach.
(B) As you breathe in, the stomach seems to expand first and then the chest.
(C) Only the chest expands.
(D) Only the stomach expands.

- Q7. Which Indian state is referred to as the "Spice Garden of India"?
(A) Karnataka (B) Kerala
(C) Uttar Pradesh (D) Rajasthan

Q8. The grey area marked in the given map of India is the river basin of an important river of the country.

Identify the river.

- (A) Krishna River
- (B) Tapi River
- (C) Godavari River
- (D) Mahanadi River



Q9. Which is the correct arrangement of the names of Governors of the RBI from 2016, in chronologically reverse order.

1. Raghuram Rajan 2. Y V Reddy 3. Urjit R Patel 4. D Subbarao 5. Bimal Jalan

- (A) 3, 1, 4, 2, 5
- (B) 3, 1, 2, 4, 5
- (C) 3, 1, 5, 4, 2
- (D) 3, 1, 5, 2, 4

Q10. Which of the following pairs of devices had the same inventor?



(A)

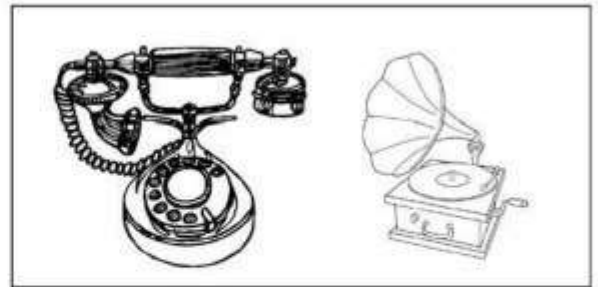

(B)

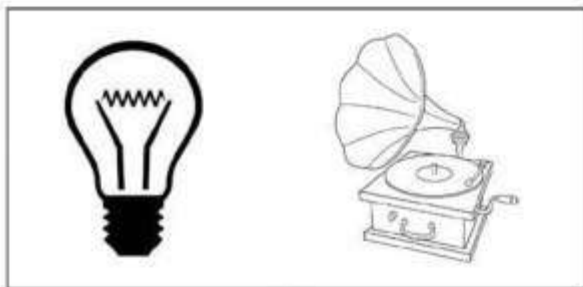

(C)

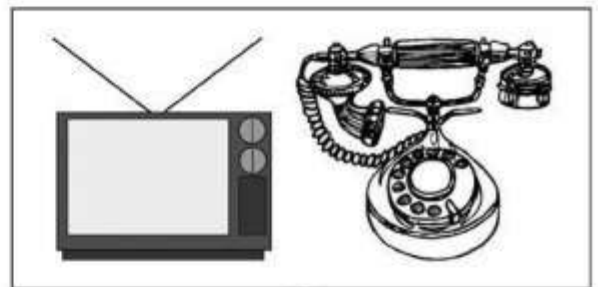

(D)

Q11. Which is the only planet in the Solar System that is not named after any mythological God?

- (A) Venus
- (B) Earth
- (C) Jupiter
- (D) Mercury

Q12. Telangana is the youngest state in the Republic of India and was established on 2nd June 2014. Which of the following was the youngest state in India before that?

- (A) Chattisgarh
- (B) Uttarakhand
- (C) Jharkhand
- (D) Arunachal Pradesh

Q13. The component "Ferrule" is associated with which of the following objects?

- (A) Eraser
- (B) Brush
- (C) Paper
- (D) Board clip

Q14. Which of the following is an Indian Classical dance form of North India?

- (A) Kathak
- (B) Kathakali
- (C) Kuchipudi
- (D) Bharatnatyam

Q15. How many cubes can you identify in the given image?

- (A) 1
- (B) 27
- (C) 32
- (D) 36

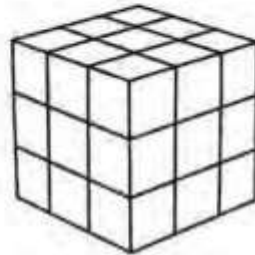

Q16. Who is the first Indian woman to win an Olympic Medal?

- (A) Saina Nehwal
- (B) MC Mary Kom
- (C) Karnam Malleshwari
- (D) Sakshi Malik

Q17. Albert Einstein was awarded the Nobel Prize in 1921 for

- (A) The equation $E = MC^2$
- (B) The Photoelectric Effect
- (C) The Special Theory of Relativity
- (D) Quantum Mechanics

Q18. If

Blue is



Red is

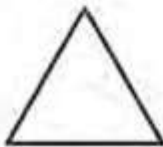

Yellow is



Purple is

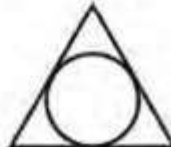

Green is

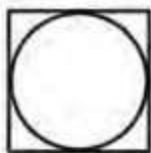

A

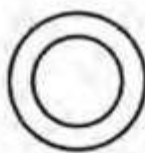

B

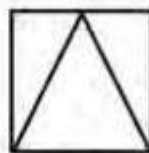

C

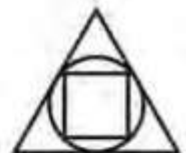

D

Q19. The leaves of plants are green in colour due to the presence of

- (A) Chloride.
- (B) Chlorophyll.
- (C) Hydrocarbon.
- (D) Sulphide.

Q20. Identify the set of countries where Tamil is recognized as an official language.

- (A) India, Sri Lanka and Mauritius
- (B) Mauritius, Malaysia and India
- (C) India, Malaysia and Indonesia
- (D) Singapore, Sri Lanka and India

Q21. What is the fourth element in the sequence: 2j, 4g, 6d, ____?

- (A) 4f (B) 8a
(C) 10g (D) 8f

Q22. Which is true for the figures shown, moving from left to right? ('Area' and 'Perimeter' refer to the total area and perimeter of the black shapes in each figure)?

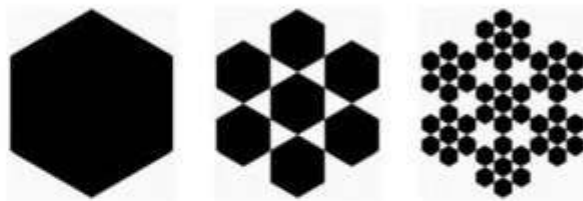

- (A) Area increases and perimeter increases
(B) Area decreases and perimeter increases
(C) Area increases and Perimeter decreases
(D) Area decreases and Perimeter decreases

Q23. In an atom, which of the following is a particle which is positively charged?

- (A) Neutron (B) Electron
(C) Mitron (D) Proton

Q24. is the particle that gives mass to other particles. Two physicists won the Nobel Prize in Physics in 2013 for this discovery.

- (A) Higgs Boson (B) Bohr model
(C) Black body (D) Big bang

Q25. Rita and Rahul are watching the sunset together. Rahul turns right and walks 100 meters, while Rita turns in the opposite direction and walks 100 meters. Then they both turn right and walk another 30 meters. Who is closer to the North at the end?

- (A) Rahul (B) Rita
(C) Both (D) None

Q26. You are booking a ticket to travel by air from Trivandrum to Ahmedabad and the flight time is around sunrise. Which location would give you a view of the sunrise from your seat?

- (A) A window seat on the right of the plane
(B) A window seat on the left of the plane
(C) A window seat in the front of the plane
(D) A window seat in the back of the plane

Directions: Question numbers 27 to 63 carry 1.0 marks each. Read the questions carefully and select your response from the options provided.

Q27. Three faces of the same cube are illustrated below. Which symbol lies on the face of the cube, behind the face with a heart shape?

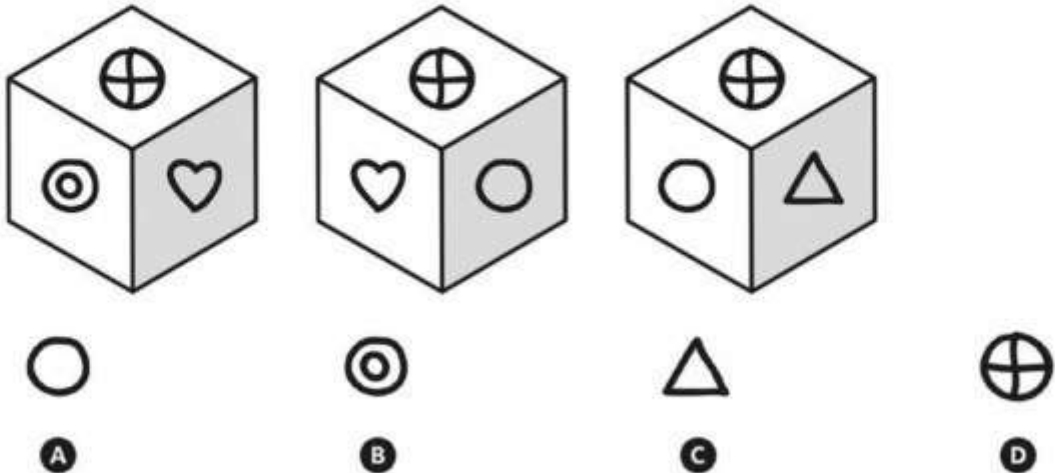

Q28. *"You may shoot me with your words, You may cut me with your eyes, You may kill me with your hatefulness, But still, like air, I'll rise. Does my sexiness upset you? Does it come as a surprise that I dance like I've got diamonds at the meeting of my thighs? Out of the huts of history's shame I rise up from a past that's rooted in pain I rise I'm a black ocean, leaping and wide, welling and swelling I bear in the tide."*

In this passage, the author is talking about

- (A) gender related violence. (B) racial violence.
 (C) racial and gender discrimination. (D) racial discrimination.

Q29. What can you put in a wooden box that would make it lighter? The more of them you put in, the lighter it becomes, yet the box stays empty.

- (A) Air (B) Cotton
 (C) Holes (D) None of these

Q30. How many triangles, rectangles and circles can you identify in the image?

- (A) 4 rectangles, 3 triangles and 1 circle
 (B) 4 rectangles, 5 triangles and 2 circles
 (C) 3 rectangles, 3 triangles and 2 circles
 (D) 2 rectangles, 3 triangles and 2 circles



Q31. Mr. Rao is late to catch his flight. As he sat tensed in his cab which was zipping through the city traffic, he wished he had not fallen to the persuasion of his daughter, whose plea he could never refuse, for having lunch with her before he left.

Based on the above, his actions can be described as

- (A) calculative. (B) glutton.
(C) careless. (D) caring.

Q32. Given below is a figure with one quadrant missing. Which of the options below will complete the figure?

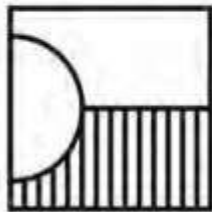
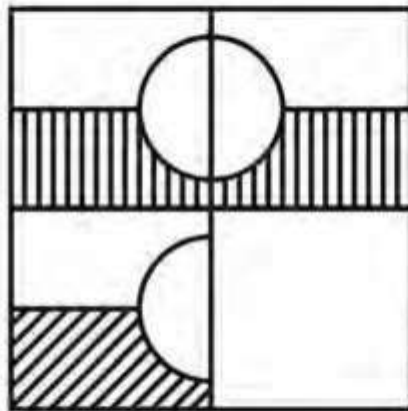

A

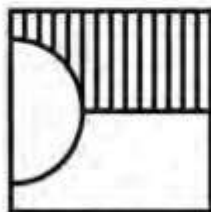

B

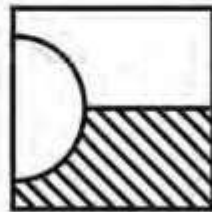

C

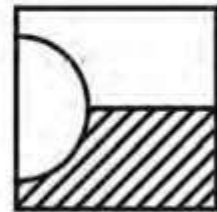

D

Q33. Meaning of this quote by Isaac Newton is close to which one of the following four options?

"If I have seen further than others, it is by standing upon the shoulders of giants."

- (A) Copying Giant's work leads to new knowledge
(B) New knowledge builds on existing knowledge
(C) Knowledge is self conscious
(D) None of these

Q34. Decipher the name of the month hidden in the image of the rebus below:

- (A) June
(B) October
(C) July
(D) May



Q35. Given below is a figure with one quadrant missing. Which of the options below will complete the figure?

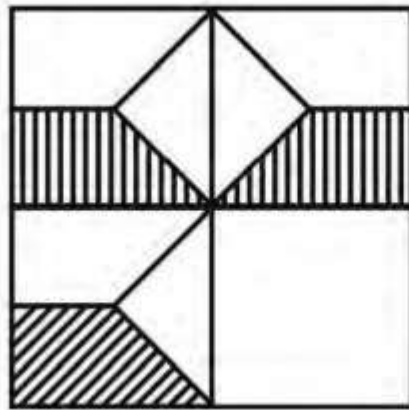

A



B

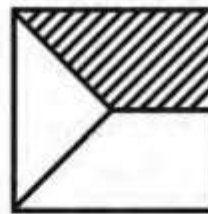

C

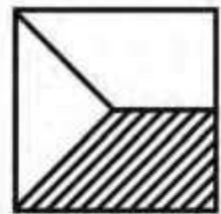

D

Q36. When a square piece of paper is folded twice and cut as shown below, which one of the given options indicates the correct figure when it is unfolded (opened).

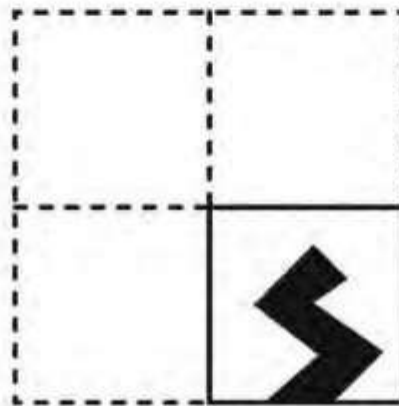

A



B



C



D

Q37. Fill in the blank space below to yield a true sentence. In this sentence there are neither more nor less than three-letter words.

- (A) five
- (C) Two

- (B) Four
- (D) Three

Directions: Read the paragraph carefully to answer question numbers 38 to 40.

"The superstorm that struck New York in 2012, Hurricane Sandy, was one such highly improbable phenomenon: the word unprecedented has perhaps never figured so often in the description of a weather event. In his fine study of Hurricane Sandy, the meteorologist Adam Sobel notes that the track of the storm, as it crashed into the east coast of the United States, was without precedent: never before had a hurricane veered sharply westward in the mid-Atlantic. In turning, it also merged with a winter storm, thereby becoming a 'mammoth hybrid' and attaining a size unprecedented in scientific memory. The storm surge that it unleashed reached a height that exceeded any in the region's recorded meteorological history.... "

Q38. Amongst the statements below, related to the passage above, which combination of statements can be said to be the most incorrect?

1. Hurricane Sandy is the name of a very big winter storm that struck New York in 2012.
2. Adam Sobel does not remember of having heard of a hurricane as large as Sandy in his lifetime.
3. The use of the word unprecedented so often in describing a superstorm is unprecedented.
4. 'Mammoth hybrid' is another name for the superstorm that struck New York in 2012.
5. Hurricane Sandy unleashed waves of such heights that were unprecedented in the meteorological history of New York.
6. The probability for a hurricane to veer sharply westward in mid-Atlantic and hit the West coast of America is very low.

- (A) Statements - 1, 2 and 4
- (C) Statements - 1, 4 and 6

- (B) Statements - 3, 4 and 6
- (D) Statements - 1, 3, 4 and 6

Q39. The aspects of Hurricane Sandy that were unprecedented were:

- (A) that it veered sharply westward from mid-Atlantic and crashed into the east coast of America and merged with a winter storm.
- (B) the height of the storm surge that it unleashed.
- (C) the formation of the 'mammoth hybrid' and attaining a size that has not been recorded before.
- (D) the track of the storm, the merging with a winter storm, the size that it became and the height of the storm surges created.

Q40. The term 'mammoth hybrid' that has been used to describe Hurricane Sandy refers to the

- (A) unprecedented size of the hurricane.
- (B) combination of a hurricane with a winter storm.
- (C) track of the storm – the way it veered sharply westward in mid-Atlantic and hit the East coast of America.
- (D) size and the combination of hurricane with winter storm.

- Q41. Ramprasad is Sudhir's grandfather. Nirmala is the aunt of Sudhir's father. Rekha is the daughter of Nirmala. What is the relationship between Rekha and Sudhir?
 (A) Rekha is Sudhir's aunt (B) Rekha is Sudhir's cousin
 (C) Rekha is Sudhir's grandmother (D) Rekha is Sudhir's mother

- Q42. In the following figure, find the number of rectangles and hexagons respectively:
 (A) 30, 5
 (B) 32, 3
 (C) 28, 5
 (D) 30, 3

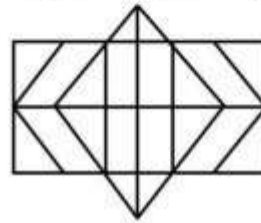

- Q43. If the average of x , y , and z is 32 and the average of y and z is 27, what is the average of x and $2x$?
 (A) 45 (B) 63
 (C) 84 (D) 90

- Q44. Identify the missing image in the pattern below:

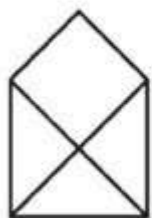
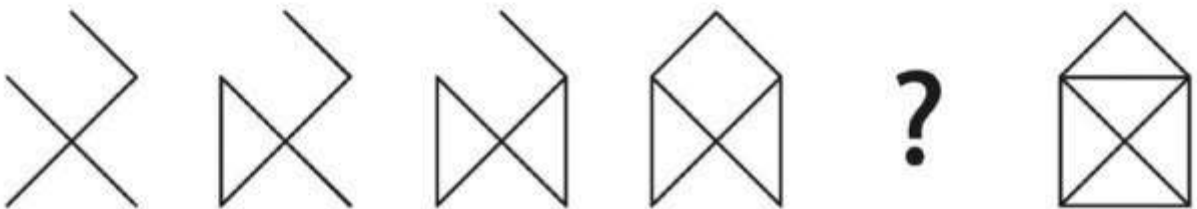

A

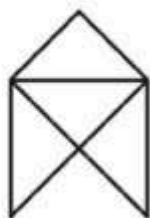

B

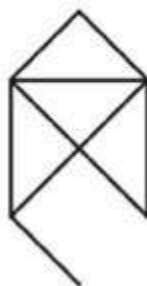

C

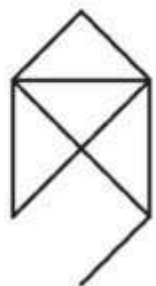

D

- Q45. In a secret code, '762' means 'shoes are old', '248' means 'grandpa is old' and '573' means 'buy good shoes'. What stands for 'are' in this code?
 (A) 2 (B) 4
 (C) 6 (D) 8

Q46. In the figure given below, which number will replace the question mark?

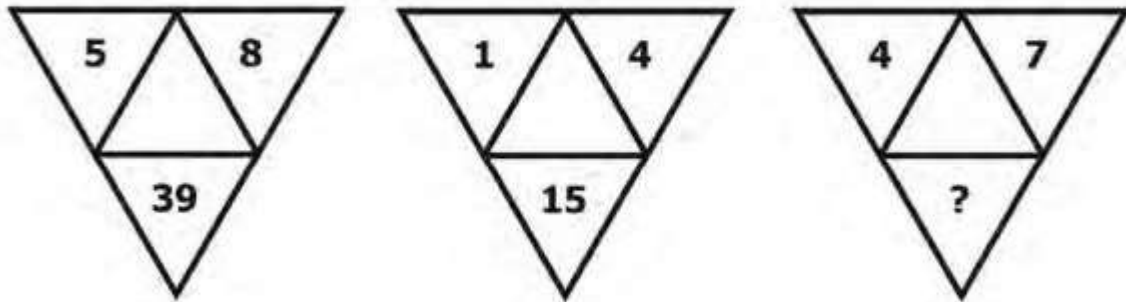

- (A) 30
- (C) 33

- (B) 28
- (D) 16

Q47. How many surfaces are there in the given three dimensional figure? The surface that is not visible in the figure is flat.

- (A) 12
- (B) 18
- (C) 16
- (D) 14

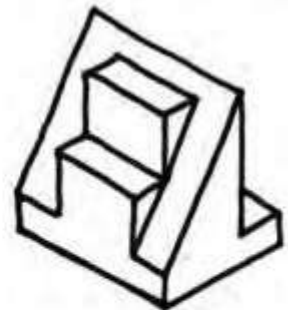

Q48. Which of the following symbols will replace the “?” to complete the series M – to – R.

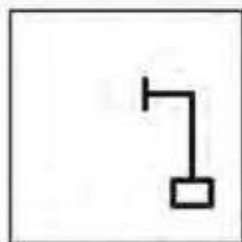
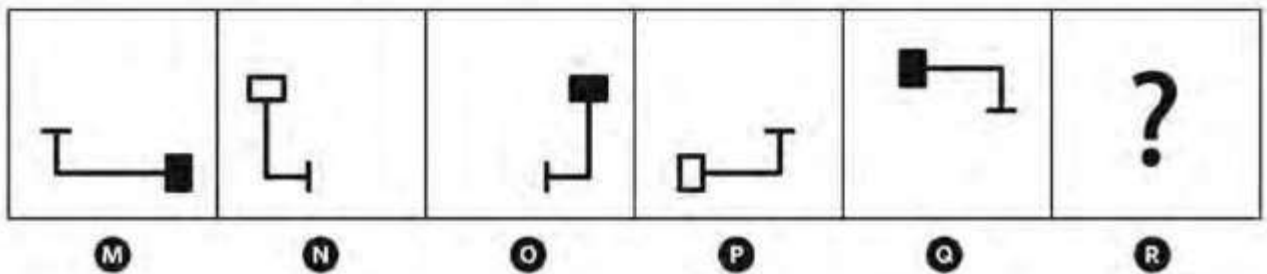

A

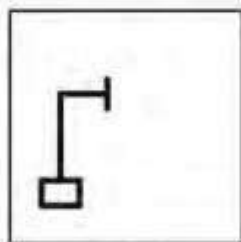

B

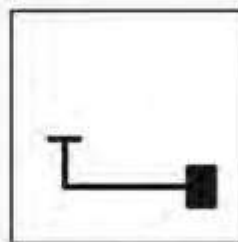

C

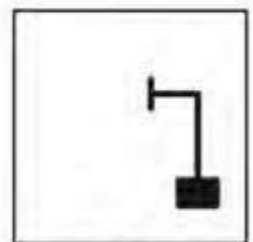

D

Q49. How can you add a sense of depth in the following image?

- (A) By overlapping one bowl on another.
- (B) By scaling down one bowl.
- (C) By thickening the outline of one bowl.
- (D) All these

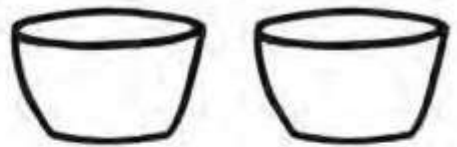

Q50. How many distinct shapes as shown in Fig A, can be found in Fig B?

- (A) 5
- (B) 4
- (C) 2
- (D) 3

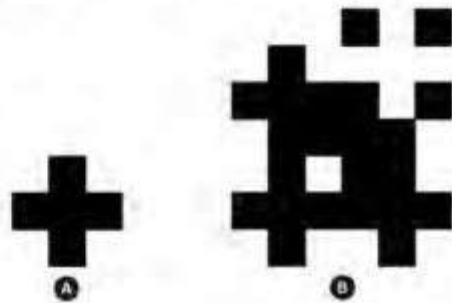

Q51. How many surfaces are there in the given three dimensional figure? The surface that is not visible in the figure is flat.

- (A) 12
- (B) 11
- (C) 10
- (D) 9

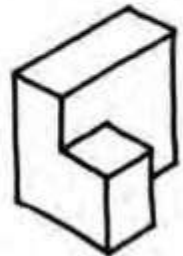

Q52. What geometric solid is formed when you fold along the lines of the given image?

- (A) Pyramid
- (B) Tetrus
- (C) Tetrahedron
- (D) Harmonica

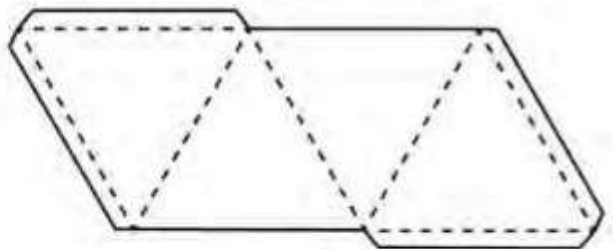

Q53. How can you give the viewer an idea about the relative size of the book in the following image?

- (A) By adding shadow.
- (B) By adding texture.
- (C) By adding eye level and vanishing point.
- (D) By adding a human figure appropriately in the image.



Q54. Make the appropriate matches between the words (from 1 to 4) and visuals (J to M).

- 1. Movement
- 2. Conflict
- 3. Stability
- 4. Harmony



J



K

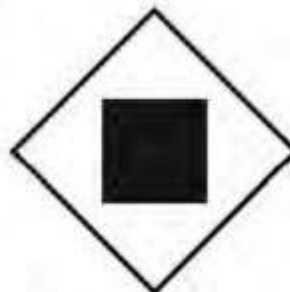

L



M

- (A) 1-K, 2-J, 3-M, 4-L
- (B) 1-L, 2-K, 3-J, 4-M
- (C) 1-K, 2-L, 3-M, 4-J
- (D) 1-M, 2-L, 3-J, 4-K

Q55. Count the number of cubes in the given image.

- (A) 8
- (B) 10
- (C) 12
- (D) 14

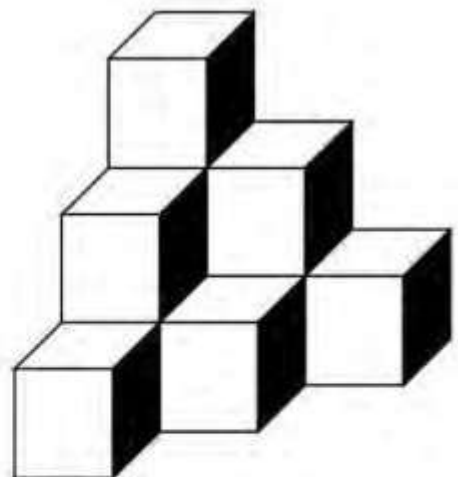

Directions: Study the four images (P, Q, R and S) to answer questions 56 to 59.

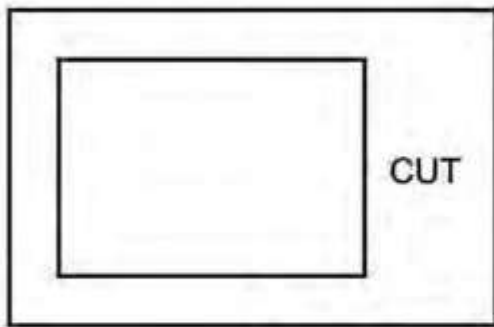

P

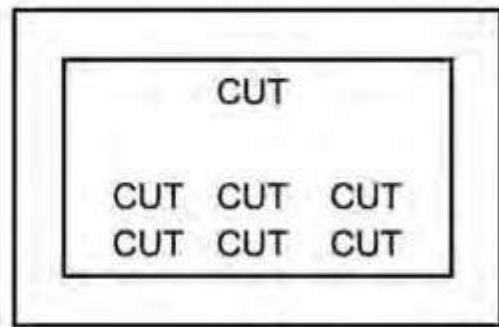

Q

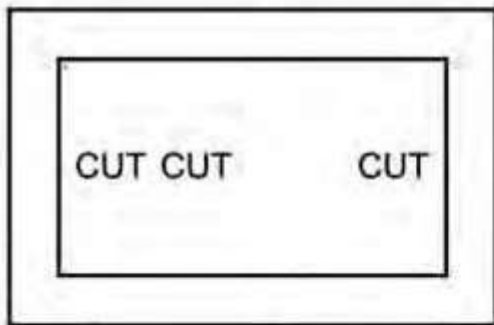

R

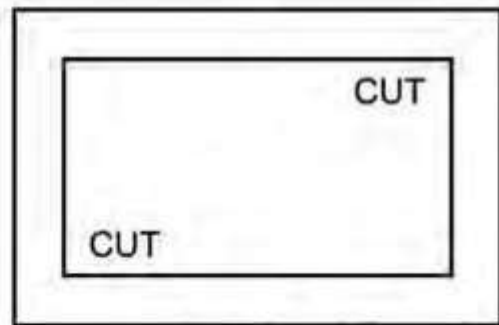

S

Q56. For the phrase 'Cut to Cut' which of the corresponding images will be appropriate?

- (A) P (B) Q
(C) R (D) S

Q57. For the phrase 'Cut it Out' which of the corresponding images will be appropriate?

- (A) P (B) Q
(C) R (D) S

Q58. For the phrase 'Cut above the Rest' which of the corresponding images will be appropriate?

- (A) P (B) Q
(C) R (D) S

Q59. For the phrase 'Cut to the Chase' which of the corresponding images will be appropriate?

- (A) P (B) Q
(C) R (D) S

Directions: Study the images below to answer questions 60 to 63.



A

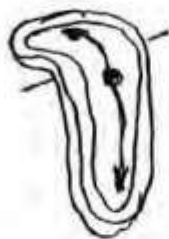

B



C



D

Q60. Which image represents “Times they are changing”?

Q61. Which image represents “Passage of Time”?

Q62. Which image represents “Time stands still”?

Q63. Which image represents “Time is money”?

Question numbers 64 to 71 carry 1.5 marks each.

Q64. *“Banaskantha, an arid place, has a tradition of cattle breeders who lead a nomadic or semi nomadic lifestyle. Some groups lead their herds from place to place throughout the year, while others only leave their native village when there are no enough resources to ensure their productivity. The former migrate out of choice. The latter, and by far the most numerous, reluctantly migrate only when there is no other choice. Having little or no private land, poor cattle-breeders are largely dependent on communal land for grazing. Usually this land is relatively poor in quality and so less productive than most private lands. In an arid place, the grasses and fodder on the communal land do not last long. The dependence of a larger number of families on that land also adds to rapid deterioration. When the area is grazed out, the poorest villagers with cattle are forced to shift to places where vegetation is more readily available. Without ample food for their animals, milk production declines and the cattle breeders get less and less income. In more extreme cases, though not uncommon in a drought, because of the scarcity of food for the animals, the breeders risk not only a temporary decline, but also a permanent loss of income and assets.”*

Why are the poor cattle breeders of Banaskantha forced to migrate?

- (A) Nomadic tradition
- (B) Early exhaustion of communal land resources
- (C) No private land
- (D) In search of better pastures

- Q65. Choose the appropriate sequence of the numbered shapes which will complete the square illustrated below.

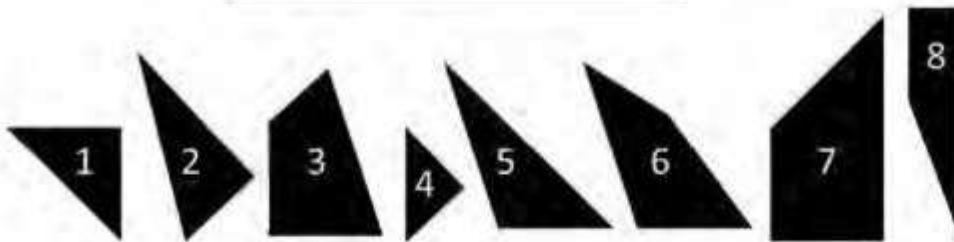
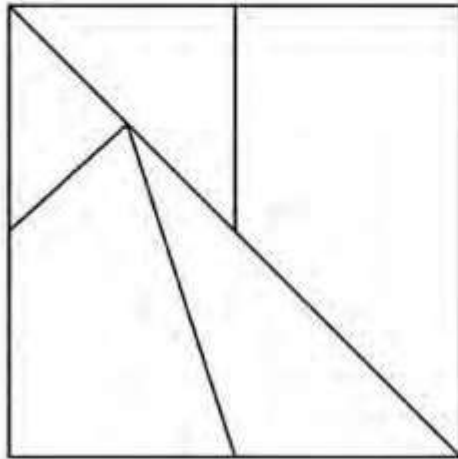

- (A) 2, 4, 5, 7, 8 (B) 1, 3, 4, 5, 7 (C) 1, 3, 4, 6, 7, 8 (D) 3, 4, 5, 6, 7, 8
- Q66. The difference between the age of the two brothers is the same as the difference in the age between their parents. The older brother is 14 years old. The mother was 30 years old when the younger brother was born. If the father is 4 years older than the mother, then what was his age when the elder brother was born?
- (A) 26 (B) 28 (C) 30 (D) 34
- Q67. There are five friends – Mahesh, Krish, Ram, Sid and Baldev - who are standing besides each other in a straight line. Ram is standing to the right of Sid. Mahesh and Krish are standing on either side of Ram. There are two persons in between Krish and Baldev. Who is standing on the extreme left?
- (A) Sid (B) Krish (C) Mahesh (D) Baldev
- Q68. Today 8th January 2017 is a Sunday.
Statement (1): 8th March 2017 is a Wednesday.
Statement (2): 8th July 2017 is a Saturday.
- Choose the correct option from below:
- (A) Statement (1) is True and Statement (2) is False
(B) Statement (1) is False and Statement (2) is True
(C) Statement (1) and Statement (2) both are False
(D) Statement (1) and Statement (2) both are True

Q69. Can you uncover the logic used to place each of the numbers below? If so, what number should be placed at the question mark?

- (A) 1
- (B) 2
- (C) 3
- (D) 4

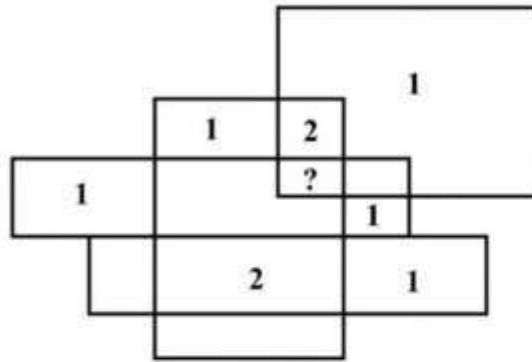

Q70. A car can average 20 km per hour up a hill, and 60 km per hour down the same road. What is the average speed for the whole trip?

- (A) 25 km per hour
- (B) 30 km per hour
- (C) 35 km per hour
- (D) 40 km per hour

Q71. A four member team from Rang Sandesh is painting Mr. Ghosla's house. Mahesh is painting the front of the house. Ramesh is in the alley behind the house painting the back. Suresh is painting the window frames on the north side, Kamlesh is on the south. If Mahesh switches places with Suresh, and Suresh then switches places with Kamlesh, where is Kamlesh?

- (A) In the alley behind the house
- (B) On the north side of the house
- (C) In front of the house
- (D) On the south side of the house

Directions: Question numbers 72 to 75 carry 2.0 marks each. Please read the questions carefully and select your response from the options provided.

Q72. These are four views of the same cube. Each face of the cube has a different pattern. Which pattern should be on the blank face with a question mark?

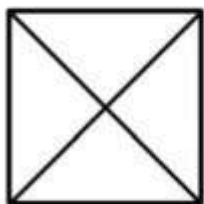
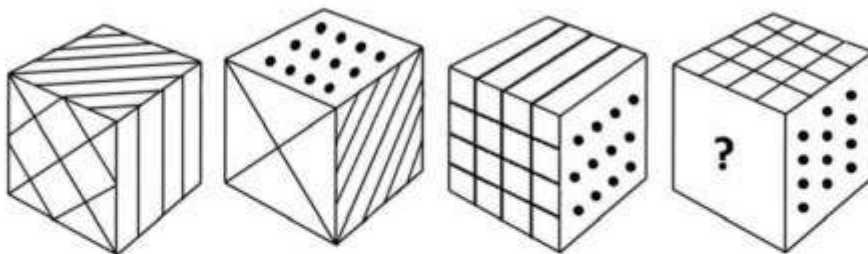

(A)

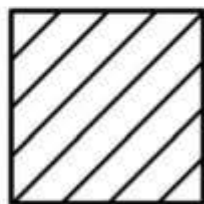

(B)

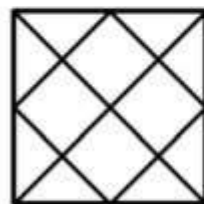

(C)

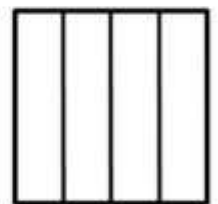

(D)

Q73. How can the statement be proven correct: $XI+I=X$?

- (A) By turning the paper at 180 degrees.
- (B) By viewing it in a mirror.
- (C) It is not possible.
- (D) All of the above are correct.

Q74. A wooden table is placed against a cardboard wall. You are given a red candle, a box of metal thumb pins, and a safety matchbox, and asked to affix the lit candle to the wall so that it will not drip wax onto the table below. Which of the following is the most efficient way to achieve the task?

- (A) Empty the box of thumb pins, use the thumb pins to nail the box to the wall, put the candle into the box, and light the candle with the match.
- (B) Pin the match box to the wall and put the candle on the box and light the candle with the match.
- (C) Pin the candle to the wall without using the thumb pin box at an angle of 45 degrees and then light the candle with the match.
- (D) Melt some of the candle's wax and use it as an adhesive to stick the candle to the wall at parallel to the wall surface and then light the candle.

Q75. Identify from the pose of hands depicted below, the shadows of the animal it may cast on the wall:

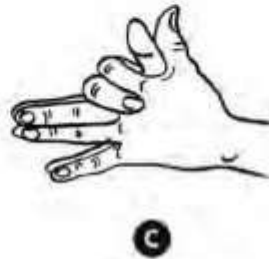
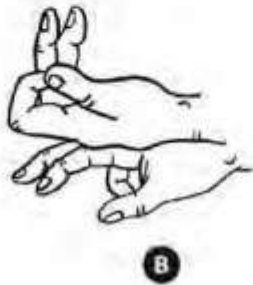
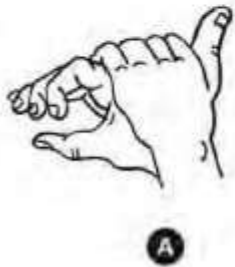

- (A) Wolf, Rabbit, Fox, Bull
- (C) Wolf, Bat, Bull, Swan

- (B) Rabbit, Crow, Swan, Bull
- (D) Crow, Swan, Fox, Bull

Q No.	Answer	Remarks
1	B, D	Two correct options. Either B or D carries equal marks
2	C	
3	C	
4	D	
5	C	
6	B	
7	B	
8	C	
9	A	
10	C	
11	B	
12	C	
13	B	
14	A	
15	D	
16	C	
17	B	
18	A	
19	B	
20	D	
21	B	
22	B	
23	D	
24	A	
25	A	
26	A	
27	C	
28	C	
29	C	
30	A	
31	D	
32	C, D	Two correct options. Either C or D carries equal marks
33	B	
34	C	
35	B, D	Two correct options. Either B or D carries equal marks
36	A	
37		1.0 mark to be given to all candidates including those candidates who have not attempted the question.

Q No.	Answer	Remarks
38	C	
39	D	
40	D	
41	A	
42	A	
43	B	
44	A	
45	C	
46	C	
47		1.0 mark to be given to all candidates including those candidates who have not attempted the question.
48	A	
49	D	
50	B	
51	D	
52	C	
53	D	
54	C	
55	B	
56	D	
57	A	
58	B	
59	C	
60	B	
61	D	
62	C	
63	A	
64	B	
65	B	
66	C	
67	A	
68	D	
69	C	
70	B	
71	C	
72	A	
73	A, B	Two correct options. Either A or B carries equal marks
74	A	
75	A	



TS
[Handwritten Signature]



राष्ट्रीय डिजाइन संस्थान
NATIONAL INSTITUTE OF DESIGN

NID B.Des 2017 Original Paper Solved by NID Alumni

SILICA
YOUR DESIGN CAREER GUIDE

Question numbers 76 to 77 carry 10 marks each.

Q76. If there was zero gravity on earth, draw yourself in your living room along with the things you would like to anchor?

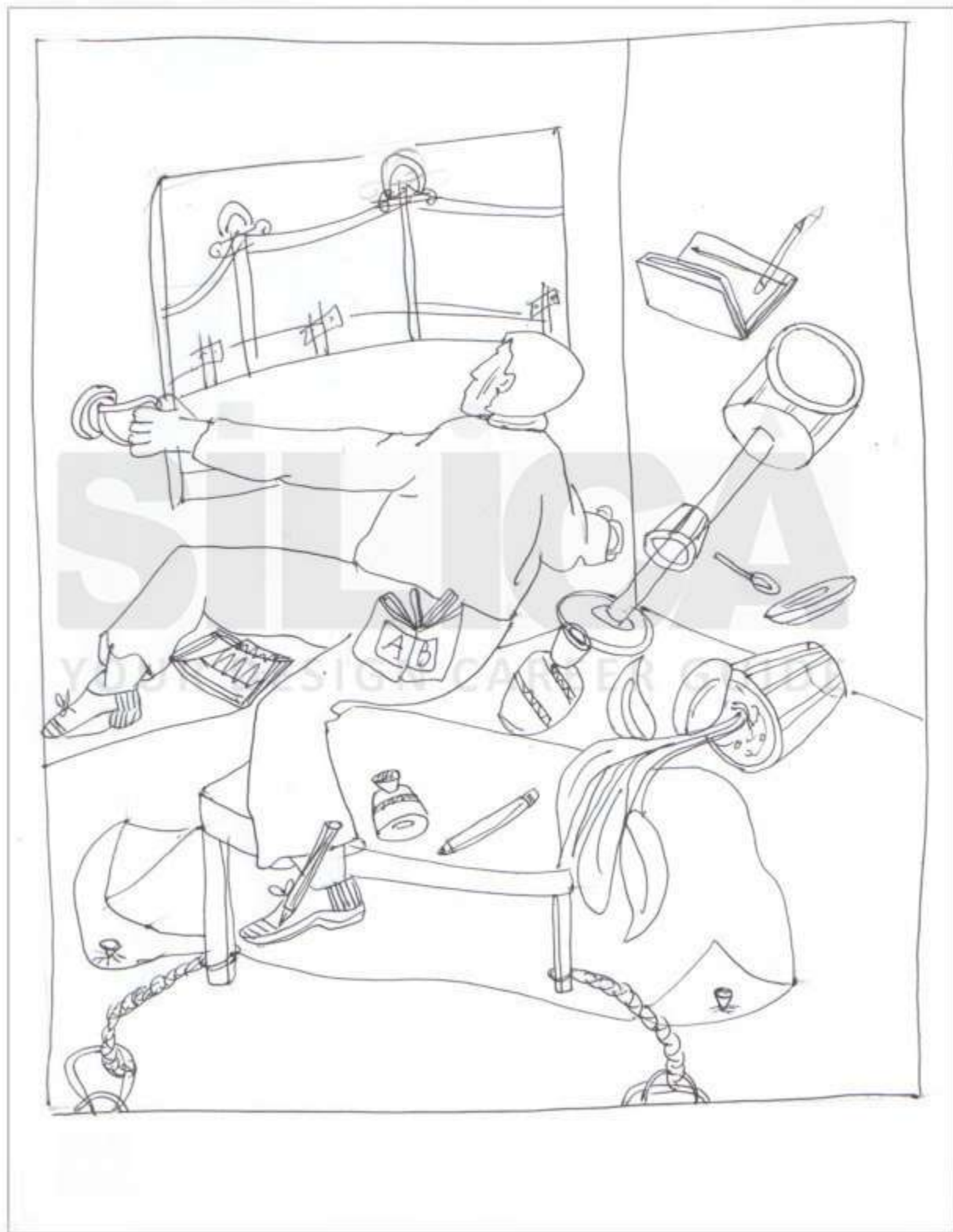

- Q77. Create a poster advertisement to promote tourism as part of the 'Incredible India' campaign, using India's national flower, India's national tree, India's national bird and India's national animal, as they are (in terms of form and colour combinations). You can use either the full form or any part of them (texture, pattern, silhouette, etc.), any number of times and in any combination (once as a part, another time as a whole, etc.).

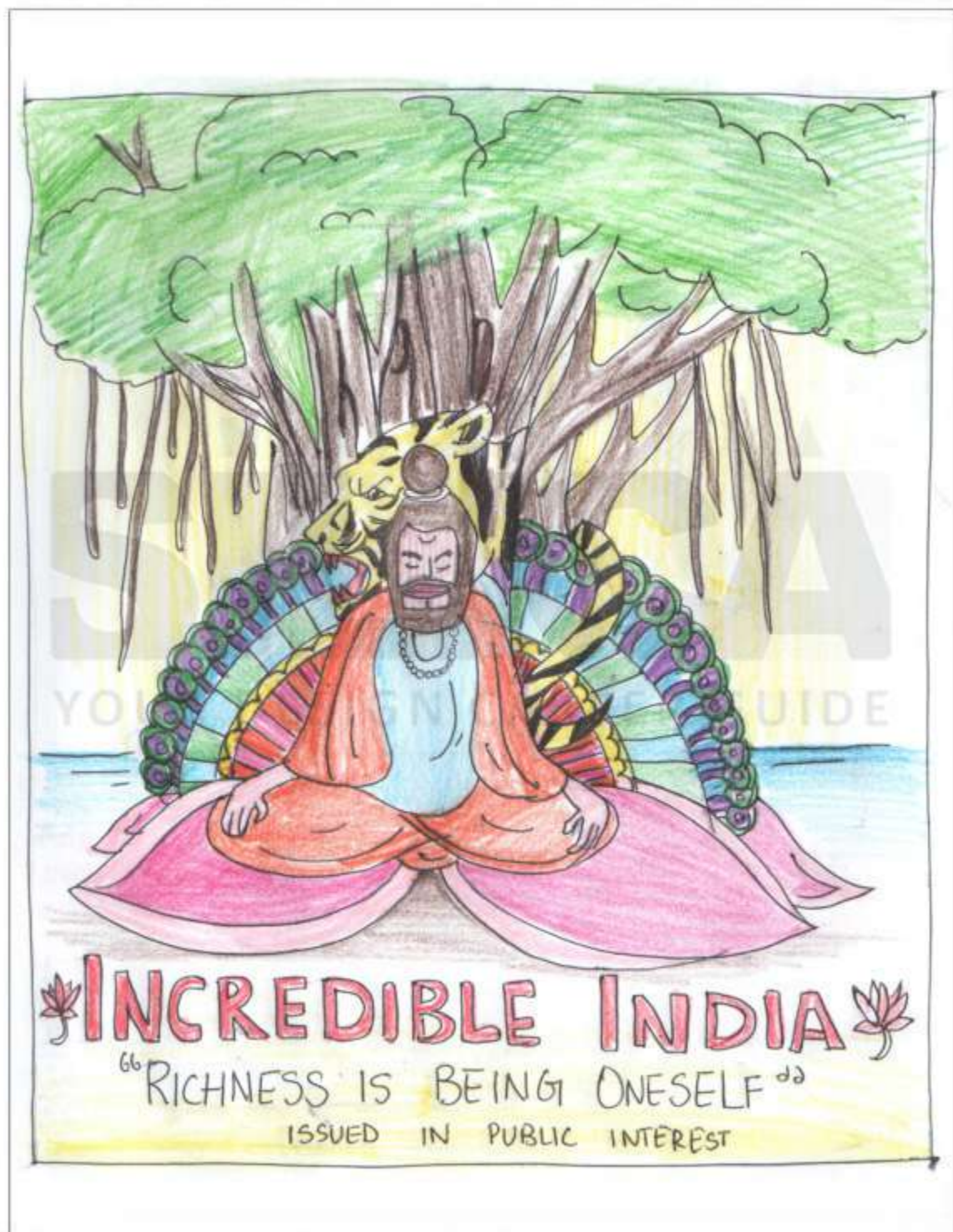

Thumbnails

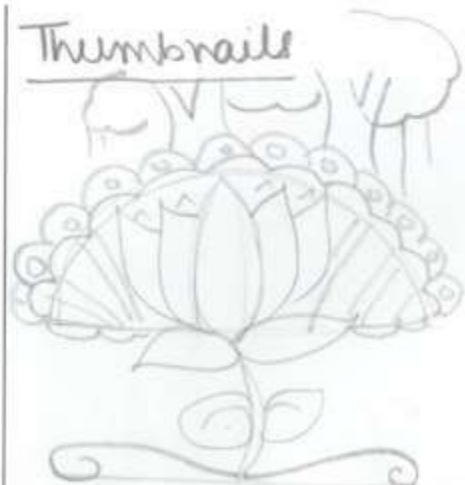

INCREIBLE
INDIA

- Using just
symbols &
textures



SILICA

YOUR DESIGN CAREER GUIDE

GUIDELINES -

- Add tagline / Header & addressing to Public.
- Combination of visuals mentioned in Question.
- A Camouflage is preferable, to cover space.
- use different pattern, text & textures together.

TIPS -

- Use visual in a way to highlight each visual.
- Visual should impact the main subject.
- Idea is to Combine textures & Patterns.
- Visuals - can be used as half / whole.

Question numbers 78 to 79 carry 5 marks each.

Q78. Draw two opposites of the meaning "Rock" in two different frames and write a one line explanation accompanying each frame.

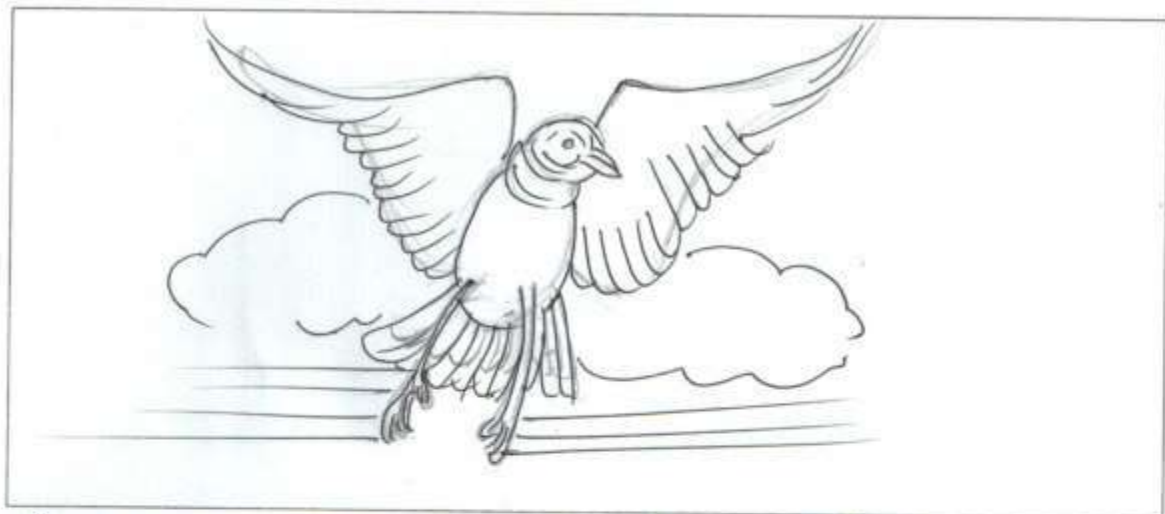

Rock as one of the constituents of earth's surface -
Signifies solid/dull/still (opposite - liquid/flowing/
full of energy or movement)
Bird - Movement - Representing energy & life.

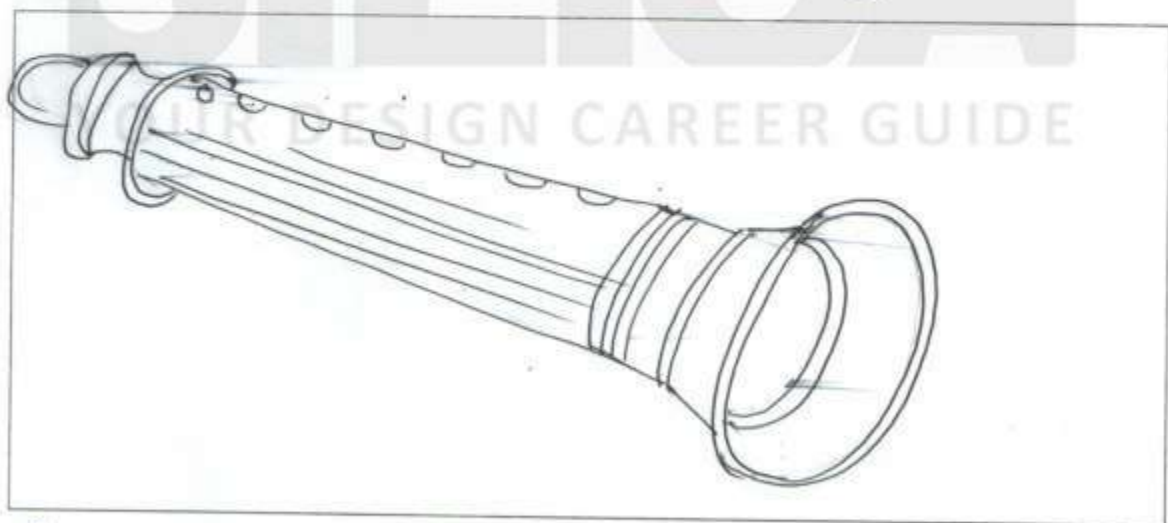

Rock as one of the genres of music - Signifies loudness,
aggressive, vibrant. (opposite - could be classical
instrument - jazz/flute/sitar etc).
Flute - Representing soft & calm music.

Q79. Draw a woman holding a child, crying in her arms, with appropriate details including the background. Your drawing should be in black and white only (Do not use any colour).



Thumbnail -



GUIDELINES -

- Think & visualise a real scenario
- Preferably more details & zoomed in view.
- Adding background & foreground in the image add more realism to it.

TIPS -

- Firstly, draw the baby with expressions & his mother.
- After the human figures are added, add background accordingly.
- Don't make it fussy, otherwise the figures will lose its importance.

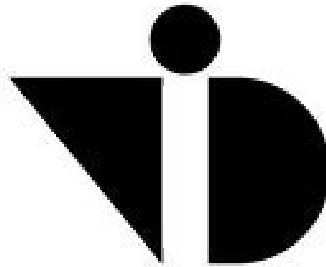

राष्ट्रीय डिजाइन संस्थान
NATIONAL INSTITUTE OF DESIGN

NID B.DES 2016

Original Paper

Solved From

SILICA
YOUR DESIGN CAREER GUIDE

Please fill in your Roll No.

--	--	--	--	--	--	--	--	--

NOTE : Confirm that the 1st and 2nd digits of your Roll No. are

1	7
---	---

 . If not, bring it to the notice of the invigilator.

Part	Pattern	Question Nos.	Marks per Question	Marking of Answers	Test Duration
I	Objective Type – Multiple Choice Questions	1 to 44	0.5	Answers of these questions are to be marked only on the OMR Answer Sheet which is provided separately, using Black ballpoint pen.	3 hours
		45 to 62	1.0		
		63 to 69	2.0		
		70 to 81	0.75		
		82 to 83	1.5		
		84 to 88	0.8		
II	Subjective Type	89 to 91	10.0	Answer of these questions are to be given in the space provided below each question on the Question-cum-Answer Booklet only.	

INSTRUCTIONS FOR CANDIDATES

- Please do not open this Question Booklet (Part I) until asked to do so.
- Fill up the necessary information in the space provided on the cover of this Question Booklet (Part I), OMR Answer Sheet and Question-cum-Answer Booklet Part II before commencement of the test.
- The total duration of this test (Part I & Part II) is 3 hours. There are 88 questions in Part I and 3 questions in Part II.
- The Test (Part I & Part II) is of total 100 marks.
- There is No Negative Marking.
- You may attempt the questions in any order you prefer.
- Please check for the completeness of the Question Booklet (Part I) & Question-cum-Answer Booklet (Part II) immediately after opening.
- Q.Nos. I to 88 are objective type questions and answers of these objective type questions are to be marked on OMR Answer sheet provided separately.**
 - Each question has four options marked (A) (B) (C) and (D).
 - Choose the correct option and darken the circle completely with a BLACK PEN ONLY against the relevant question number.
 - Use only Black Pen to darken the circle for answering.
 - Do not darken more than one circle against any question. No marks will be given for such responses.
- Rough work, if any, is to be done on the Question Booklet only. No separate sheet will be provided/used for rough work.
- Calculator, Mobile or any Electronic Gadgets, etc., are not permitted inside the examination hall.
- Candidates seeking, receiving and/or giving assistance during the test will be disqualified.
- Appropriate civil/criminal proceedings will be instituted against the candidates taking or attempting to take this Question Booklet or part of it outside the examination hall.
- The right to exclude any question(s) from final evaluation rests with the testing authority.

QUESTION BOOKLET (PART I), OMR ANSWER SHEET AND QUESTION-CUM-ANSWER BOOKLET (PART II) ARE TO BE RETURNED ON COMPLETION OF THE TEST.

PART-I. Questions 1 to 88 are multiple choice questions. The correct answer must be marked in the OMR answer sheet provided separately. Do not write your name anywhere in the booklet. This may lead to disqualification.

Question numbers 1 to 44 carry 0.5 marks each. Please read the question carefully and select your response from the options provided.

- Q1. Colours of Coriander and Cabbage fall under which colour schemes?
(A) Split Complementary (B) Analogous
(C) Complementary (D) Harmonious
- Q2. What is the full form of EMI?
(A) Equated Monthly Installments (B) Equal Money Installment
(C) Equal Monthly Investments (D) Equated Money Investments
- Q3. When you buy a mobile phone you look for the SAR value of a handset. SAR value is an indicator of Specific Absorption Rate of _____, to which human body is exposed to
(A) Radio Frequency Electrostatic Field
(B) Radio Frequency Electromagnetic Field
(C) Microwave Frequency Bioelectric Field
(D) Radioactive Electromagnetic Field
- Q4. *Cartography* is the study and practice of making
(A) Cars. (B) Maps. (C) Artwork. (D) Carts.
- Q5. *"I believe in going with the flow. I don't believe in fighting against the flow. You ride on your river and you go with the tides and the flow. But it has to be your river, not someone else's. Everyone has their own river, and you don't need to swim, float, sail on theirs, but you need to be in your own river and you need to go with it. And I don't believe in fighting the wind. You go and you fly with your wind. Let everyone else catch their own gusts of wind and let them fly with their own gusts of wind, and you go and fly with yours."*
Which one of the following options best sums up the passage above?
(A) Determination (B) Self-esteem
(C) Decision Making (D) Growth
- Q6. If a human figure is standing in front of a full length rectangular concave mirror how will her/his reflection look like?
(A) Taller and thinner (B) Shorter and fatter
(C) Taller and fatter (D) Shorter and thinner
- Q7. Among the major processes in making a cloth, *Ginning* is a process of
(A) harvesting ripped cotton bales. (B) cleaning and opening the cotton bales.
(C) spinning the yarn. (D) removing the cotton seeds.

- Q8. Which is the first silent feature film made in India?
 (A) Alam Ara by Ardeshir Irani (B) Shakuntala by Suchet Singh
 (C) Devdas by Naresh Mitra (D) Raja Harishchandra by Dadasaheb Phalke
- Q9. Which airport in India became fully solar powered in 2015?
 (A) Cochin International Airport (B) Bengaluru International Airport
 (C) Chennai International Airport (D) Hyderabad International Airport
- Q10. Which is the most abundantly available fossil fuel in India?
 (A) Natural Gas (B) Coal (C) Petroleum (D) Biogas
- Q11. Which of the following does the term Corporate Social Responsibility (CSR) relate to?
 (A) Ethical conduct (B) Environmental practices
 (C) Human rights & employee (D) All these
- Q12. Select the odd one out:
 (A) Bimal Roy, Mrinal Sen, Satyajit Ray
 (B) Ravindranath Tagore, Mahatma Gandhi, Bal Gangadhar Tilak
 (C) Manto, Chughtai, Gulzar
 (D) Shabana Azmi, Prasoon Joshi, Sayeed Jaffery
- Q13. What is the colour of a Black Box of a commercial aircraft?
 (A) Black (B) Green (C) Pink (D) Orange
- Q14. Which shape will match the cross section of a Ladyfinger (vegetable)?
 (A) Octagon (B) Hexagon (C) Pentagon (D) Septagon
- Q15. An example of Interactive Voice Response System (IVRS) that is used in our day-to-day life is
 (A) The Telephone Enquiry Service. (B) The Cloud Computing Service.
 (C) The Web Server Service. (D) None of these
- Q16. Which Indian sportsperson attained World Rank number one (Singles title) in 2015?
 (A) Saina Nehwal (B) Sania Mirza (C) Jwala Gutta (D) Ashwini Ponappa
- Q17. The Industrial Revolution that took place in Europe around 1750 A.D. began in which of the following countries?
 (A) Germany (B) France (C) Italy (D) England
- Q18. Who is considered to be the Father of India's Atomic Energy Programme?
 (A) Raja Ramanna (B) Homi Bhabha
 (C) Vikram Sarabhai (D) Dr. A P J Abdul Kalam

- Q19. With reference to your current location, identify the city, which is most eastward located:
 (A) Singapore (B) Hong Kong (C) Manila (D) Jakarta
- Q20. Which of the following statements is false?
 (A) Mahabharata is narrated by Ved Vyas
 (B) Valmiki authored Ramacharitmanas
 (C) Meghadootam is composed by Kalidasa
 (D) Yayati is written by Girish Karnad
- Q21. The death of which rationalist Kannada writer triggered a spate of protests by the Indian literary, artistic, film making and scientific community in 2015?
 (A) Govind Pansare (B) Channabasam
 (C) Narendra Dabholkar (D) Dr. M.M.Kalburgi
- Q22. What are the dates 9/11, 26/11 and 13/11 known for?
 (A) Earthquakes (B) Terrorist Attacks
 (C) Tsunamis (D) Deaths of famous personalities
- Q23. Which of the following is considered among the four old world river valley cultures apart from Indus Valley, Egypt, and Yellow River Valley of China?
 (A) Mesoamerica (B) Mesopotamia (C) Andes (D) Byzantium
- Q24. The following picture depicts
 (A) remote crawler.
 (B) hilly-biller space-walker.
 (C) stark lemon squeezer.
 (D) voyager 12.



- Q25. The rate of inflation in India is measured generally with respect to movement of
 (A) consumer price index. (B) cost of living index of agriculture labour.
 (C) wholesale price index. (D) money supply.
- Q26. Select the appropriate adjective for the word *RIVER*
 (A) Labyrinthine (B) Wolverine (C) Serpentine (D) Intertwine
- Q27. Refugees from which country migrated to Europe en masse in 2015?
 (A) Serbia (B) Libya (C) Siberia (D) Syria

Q28. Name the states of the folk art forms below in their respective order:



(i) Madhubani



(ii) Warli

- (A) Tamil Nadu and Telangana respectively
- (B) Bihar and Maharashtra respectively
- (C) Orissa and Gujarat respectively
- (D) Kerala and Karnataka respectively

Q29. Google doodle pays tribute to which Indian personality in the following image?



- (A) Sudhir Tailang
- (B) Bal Thackeray
- (C) R K Laxman
- (D) Neelabh Banerjee

Q30. The symbol © stands for

- (A) Rights of Control.
- (B) Registered Company Logo.
- (C) Copyright.
- (D) Contact Information.

Q31. Which astronomer first claimed that the earth, the moon and the other planets revolve around the sun?

- (A) Galileo Galilei
- (B) Nicolaus Copernicus
- (C) Ptolemy
- (D) Isaac Newton

Q32. Fostering cultural collaboration is one of the objectives of which of the following UN body?

- (A) UNICEF
- (B) UNIDO
- (C) UNESCO
- (D) UNO

Q33. Which of the materials listed below does not have Earth as the source?

- (A) Clay (B) Metal (C) Leather (D) Plastic

Q34. Air pollution can be of

- (A) natural origin. (B) artificial or man-made origin.
(C) Both (A) & (B) (D) None of these

Q35. Apart from the light bulb, Thomas Edison is attributed to the invention of

- (A) Telegraph. (B) Monograph. (C) Phonograph. (D) Seismograph.

Q36. Which country experienced an earthquake, a tsunami and a nuclear accident in March 2011?

- (A) Pakistan (B) China (C) Japan (D) India

Q37. Which country recycles most of its garbage to produce electricity, and imports garbage from its neighbours?

- (A) Sweden (B) Japan (C) Switzerland (D) Canada

Q38. Who is the creator of Amar Chitra Katha?

- (A) Premchand (B) Baba Ram Dev (C) Mohandas Pai (D) Anant Pai

Q39. The following drawing is the inside view of the Basilica of St. Maria Maggiore by Giovanni Batista Piranesi (1768). It is an example of



- (A) 2 point perspective drawing. (B) 3 point perspective drawing.
(C) 1 point perspective drawing. (D) None of these

Q40. The Jataka Tales are better known works of which literature?

- (A) Upanishads (B) Sangam (C) Jaina (D) Buddhist

Answer the questions 41 to 44 based on the living and non-living things listed below.

(A) Monkey

(B) Star Fish

(C) Snow Flakes

(D) Water Splash

Q41. Which of the living and non-living things demonstrates radial symmetry?

Q42. Which of the living and non-living things demonstrates six-fold symmetry?

Q43. Which of the living and non-living things demonstrates bilateral symmetry?

Q44. Which of the living and non-living things demonstrates five-fold symmetry?

Question numbers 45 to 62 carry 1.0 mark each. Please read the question carefully and select your response from the options provided.

Below is an excerpt taken from the book titled 'Thinking Design', an NID publication. Read the paragraph carefully and answer questions 45 and 46.

"Built environment: rural roots and urban influences-India lives in its villages. Approximately eighty percent of India's population is rural; spread over half a million villages. Rural houses, in contrast to urban houses, are built on line evolved over thousands of years of aesthetic traditions, indigenous techniques and judicious use of the local materials such as mud, grass, bamboo, cane. Palm and coconut leaves predominate in the rural habitat in the lush green South India, while stone and sand create or adorn houses in vast desert areas of Northwest Kutch. Their design makes great ecological sense because of the use of renewable materials and great aesthetic sense because of its being in harmony with the natural surroundings.

The houses and the spaces in and around are arranged to suit the local climate. The Kutch desert houses for example are built with thick walls and small openings and narrow passages between the houses to overcome the gale of strong winds, the dust and the heat".

Q45. Which are the local materials stated for South India?

(A) Coconut leaves and stone

(B) Palm leaves and sand

(C) Coconut leaves and Palm Leaves

(D) Stone and Sand

Q46. What are the building techniques used in Kutch houses to tackle the local climate?

(A) Thick walls

(B) Small openings

(C) Narrow space between buildings

(D) All these

Q47. Select the odd one out from the given figures:

- (A) 7
- (B) 4
- (C) 1
- (D) 6

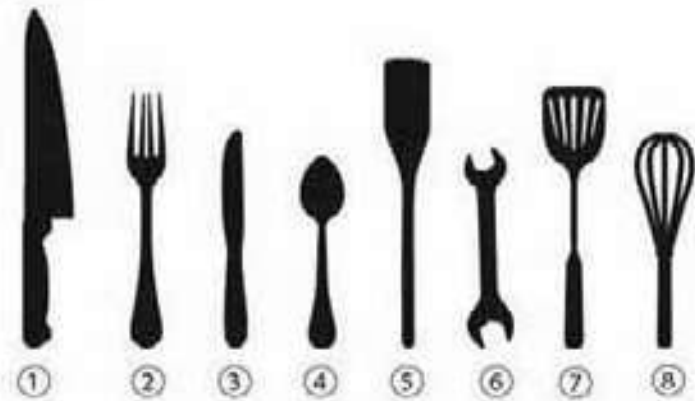

Q48. Identify the footprints in the sequence:

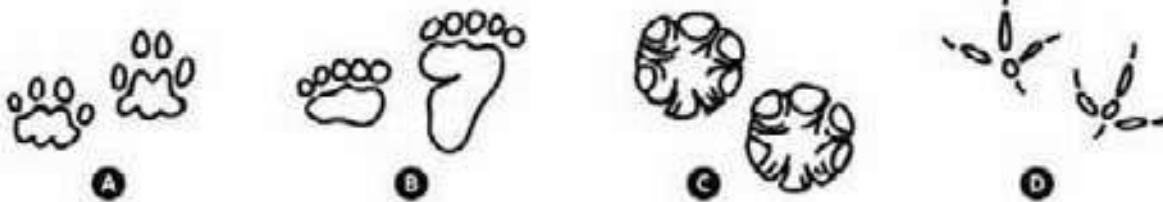

- (A) Cat, Man, Tusker, Sparrow
- (C) Cat, Bear, Elephant, Crane

- (B) Tiger, Man, Elephant, Crow
- (D) Bear, Cat, Elephant, Crane

Q49. What will be the most probable pose at position 3, to complete the sequence below?

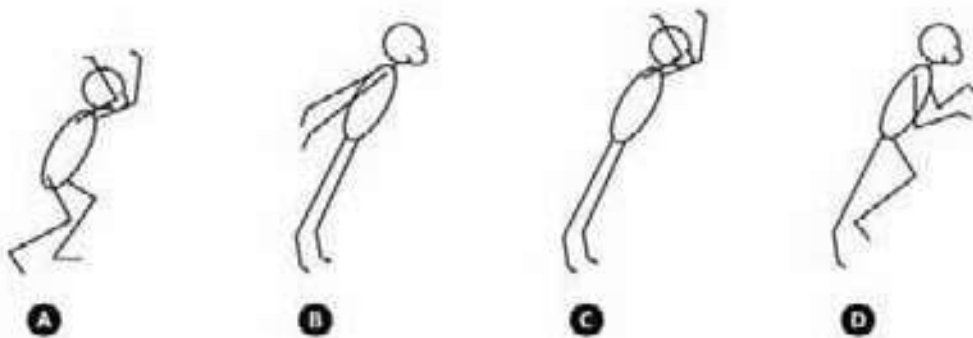
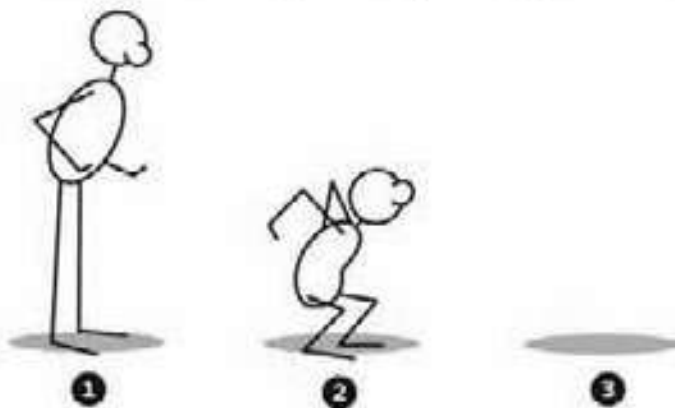

Q50. Which piece fits the jigsaw below?

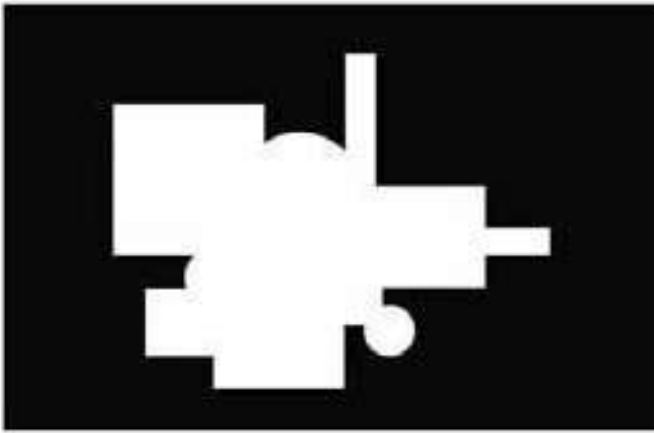

A



B



C



D

Q51. What is the width to length ratio of the leaf?

- (A) 1:1
- (B) 1:3
- (C) 1:4
- (D) 1:10



Q52. Strips of two metals 1 and 2 are firmly joined together as shown in figure below.



On heating 1 expands more than 2 does. If this joined strip is heated, it will appear as:



A



B



C



D

Q53. Choose the correct statement associated with all the three images below:

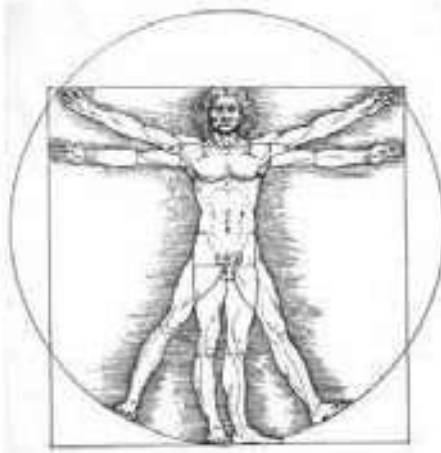

Vitruvian Man

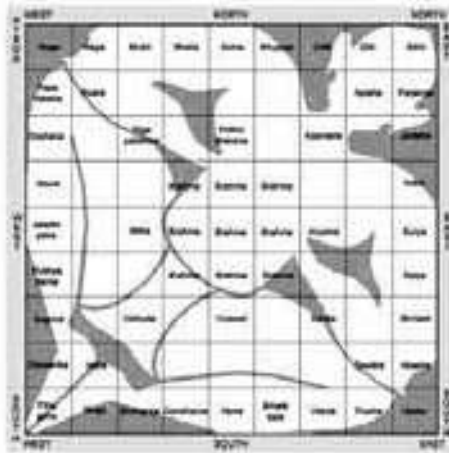

Vastupurusha Mandala

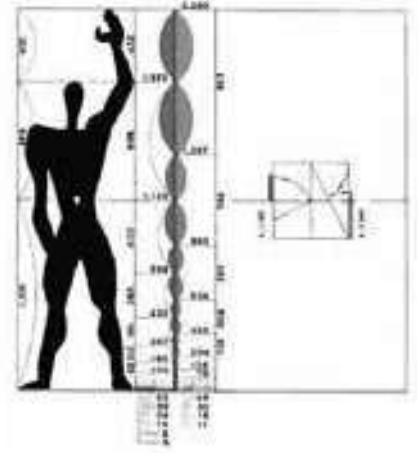

Le Modulor

- (A) All of them are artworks
- (B) All of them refer to proportions in buildings and objects
- (C) Vastupurusha Mandala does not belong to the set of visuals
- (D) None of the given above is true

Q54. Select the right set of animals that corresponds correctly to the set of four patterns of animal skins given below:



1

2

3

4

- (A) 1 Tiger, 2 Giraffe, 3 Zebra, 4 Hyena
- (B) 1 Tiger, 2 Leopard, 3 Zebra, 4 Wild cat
- (C) 1 Tiger, 2 Hyena, 3 Zebra, 4 Leopard
- (D) 1 Tiger, 2 Leopard, 3 Zebra, 4 Giraffe

Q55. Find out the next 'Number' in the series:

2 3 5 8 _____

- (A) 11
- (B) 13
- (C) 12
- (D) 14

Q56. How many squares do you see in this picture?

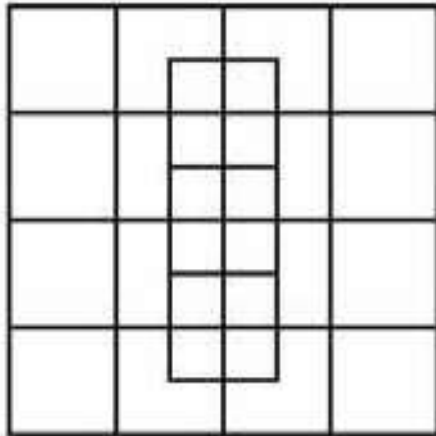

(A) 28

(B) 40

(C) 45

(D) 32

Q57. Which of the following shapes has the largest surface area?

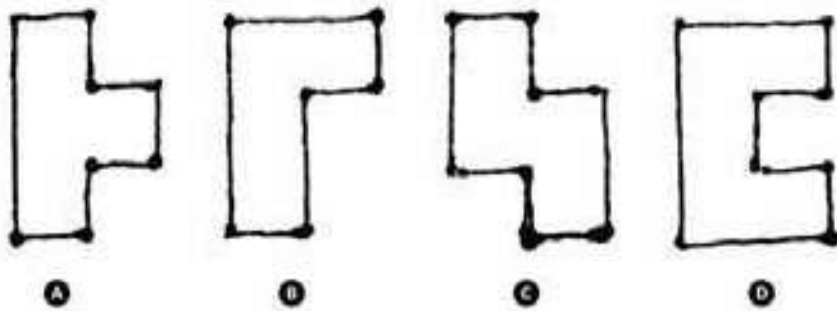

Q58. Which ball will arrive at point B in the given figure, with maximum speed, if released from point A? NOTE: all the balls are solid and are of the same size.

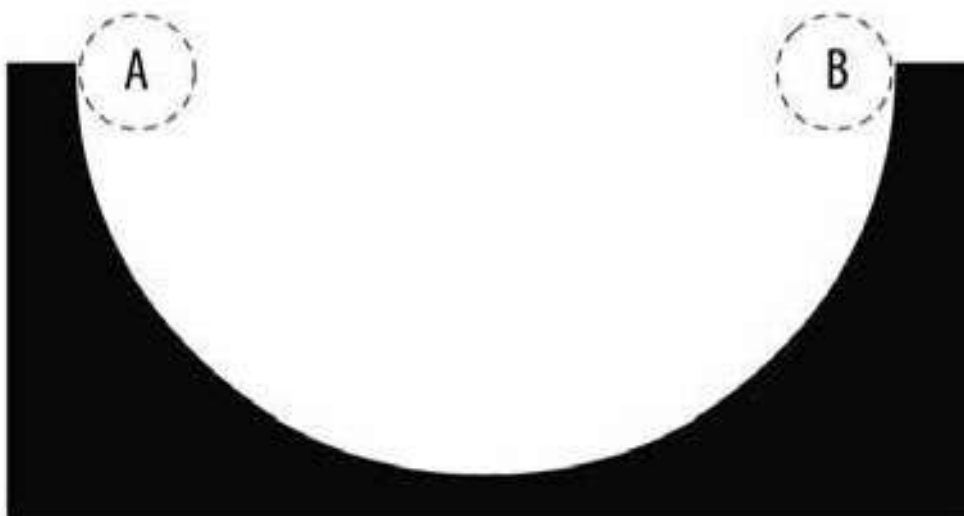

(A) Iron ball

(B) Plastic ball

(C) Wooden ball

(D) Rubber ball

Q59. If we double the weight (W), what happens to M, N, O, P in the figure?

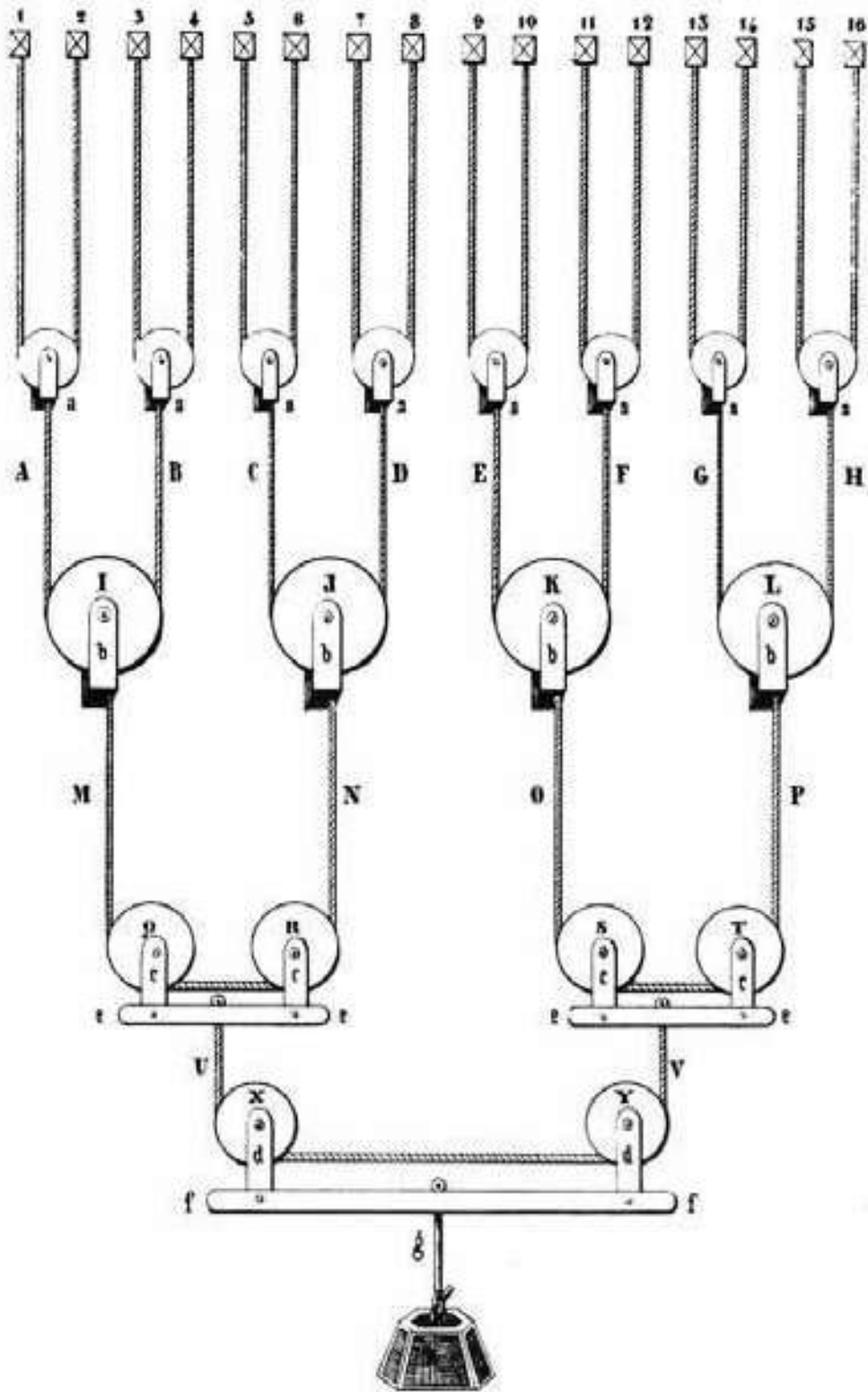

- (A) M & N go up and O & P come down
- (C) M & N come down and O & P go up

- (B) M & O go up and N & O come down
- (D) None of these

Q60. Match the following:

Medium

- p) Air-borne
- q) Water borne
- r) Contact
- s) Wound

Disease

- 1. Tetanus
- 2. Tuberculosis
- 3. Cholera
- 4. Syphilis

- (A) p-4, q-3, r-2, s-1 (B) p-3, q-2, r-4, s-1 (C) p-2, q-3, r-4, s-1 (D) p-2, q-3, r-1, s-4

Q61. Identify the odd one out:

- (A) Clip (B) Pin (C) Staple (D) Punch

Q62. Match the number of each skeleton to its name:



1



2



3

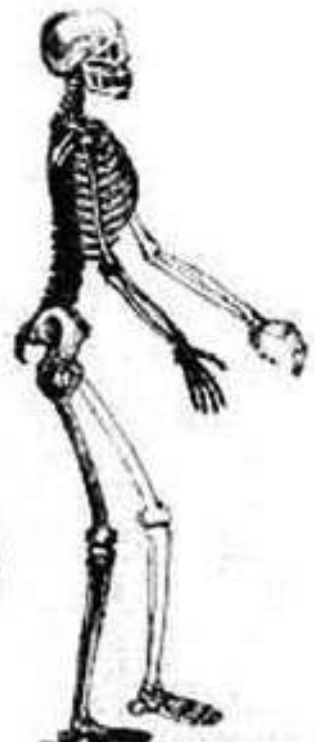

4

M-Man, G-Gorilla, O-Orangotang, C-Chimpanzee

- (A) M-4, G-3, O-2, C-1 (B) M-3, G-4, O-2, C-1
(C) M-4, G-3, O-1, C-2 (D) O-1, C-2, G-3, M-4

Question numbers 63 to 69 carry 2 marks each. Please read the question carefully and select your response from the options provided.

Q63. How many individual circles, triangles and squares can you identify in the image below?

- (A) 1 Circle, 1 Square, 1 Triangle
- (B) 2 Circles, 2 Squares, 2 Triangles
- (C) 1 Circle, 2 Squares, 3 Triangles
- (D) None of these

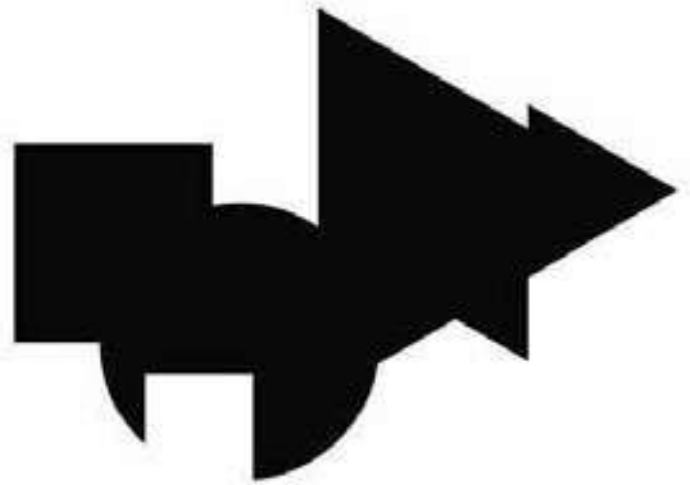

Q64. Which piece can be used multiple times to fill the shape below?

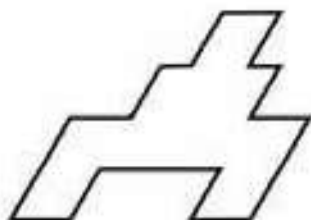
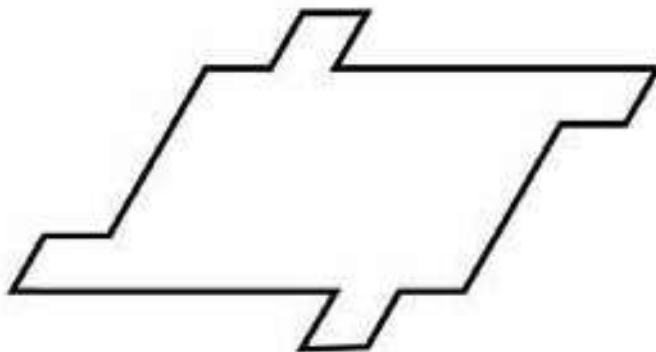

A

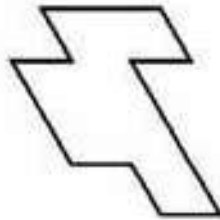

B

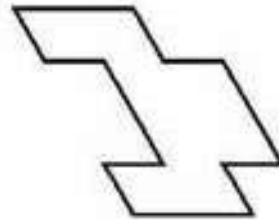

C

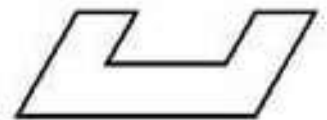

D

Q65. If we pull the points X and Y in both the cases given below, then which of the following statements is true?

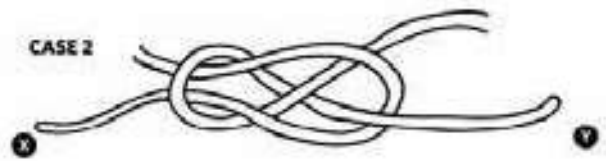
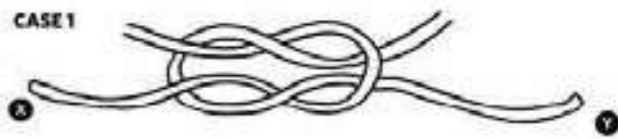

- (A) The knot in case (1) loosens and the knot in case (2) tightens
- (B) The knots in both cases are tightened
- (C) The knots in both cases become loose
- (D) The knot in case (1) tightens and the knot in case (2) loosens.

Q66. In the question given below, two statements are labelled as Assertion (A) and Reason (R).
 Assertion (A): In inflation there is increase in money-supply and the rise in the price level.
 Reason (R): The rise in price level is due to shortage in supply of essential consumer goods.

In the context of two statements, which of the following is correct?

- (A) Both (A) & (R) are true and (R) is the correct explanation of (A)
- (B) Both (A) & (R) are true, but (R) is not the correct explanation of (A)
- (C) (A) is true, but (R) is false
- (D) (A) is false, but (R) is true

Q67. Given below are the average minimum and maximum temperatures of a city measured during the year:

Month	Min ^o C	Max ^o C
January	23	30
February	23	31
March	24	31
April	24	33
May	24	34
June	25	34
July	25	33
August	24	34
September	24	34
October	23	35
November	25	28
December	21	31

Identify the city:

- (A) Cape Town
- (B) Auckland
- (C) Singapore
- (D) Ahmedabad

Q68. A film director wants an actress for the lead role of 'Helen' who perfectly fits the description that appears in the original screenplay. He is not willing to consider actresses who do not resemble the character as she is described in the screenplay, no matter how talented they are. The screenplay describes 'Helen' as an average-sized, forty something redhead, with deep brown eyes, very fair skin, and a brilliant smile. The casting agent has four actresses in mind:

- Actress#1 is a stunning red-haired beauty who is 5'9" and in her mid-twenties. Her eyes are brown and she has an olive complexion.
- Actress#2 has red hair, big brown eyes, and a fair complexion. She is in her mid-thirties and is 5'5".
- Actress#3 is 5'4" and of medium build. She has red hair, brown eyes, and is in her early forties.
- Actress#4 is a blue-eyed red head in her early thirties. She's of very slight build and stands at 5'.

Select the right actress options for the director:

- (A) 1 and 2 (B) 2 and 3 (C) 1 and 4 (D) 2 and 4

Q69. What is the common word that can be used together with all of the following words?

Blood, Cheese, Music, Moon

- (A) Red (B) Blue (C) Bone (D) None of these

Questions 70 to 81 carry 0.75 marks each. Please read the question carefully and select your response from the options provided.

Study the given images carefully and answer the questions 70 to 73.

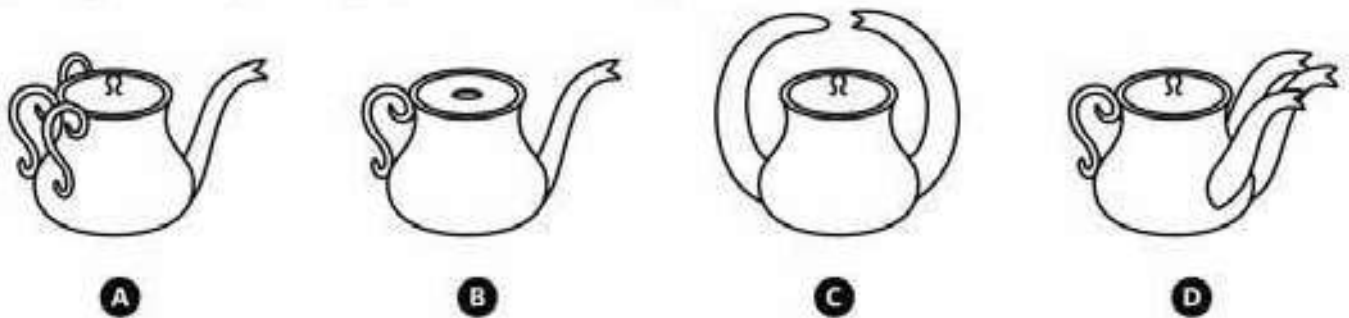

Q70. Which image represents "all that looks good might not work"?

Q71. Which image represents the phrase "too much to handle"?

Q72. Which image represents the phrase "with or without you"?

Q73. Which image represents the phrase "too many cooks spoil the broth"?

Study the given images carefully and answer the questions 74 to 77.



A



B



C



D

Q74. Which image represents the word 'classic'?

Q75. Which image represents the word 'fragile'?

Q76. Which image represents the word 'fluid'?

Q77. Which image represents the word 'masculine'?

Study the given images carefully and answer the questions 78 to 81.

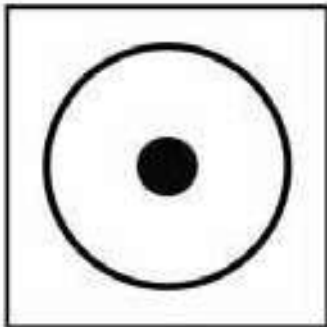

A

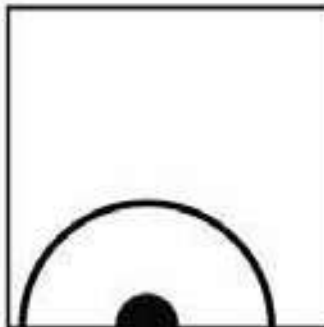

B

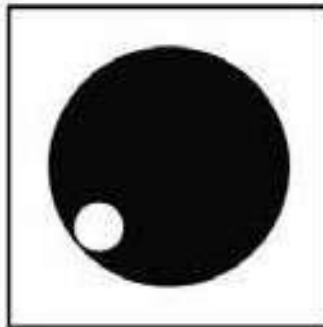

C

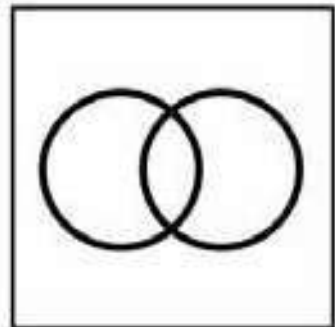

D

Q78. Which image represents the word 'stability'?

Q79. Which image represents the word 'power'?

Q80. Which image represents the word 'possessive'?

Q81. Which image represents the word 'structure'?

Questions 82 to 83 carries 1.5 marks each.

Answer the questions 82 and 83 based on the image given below.

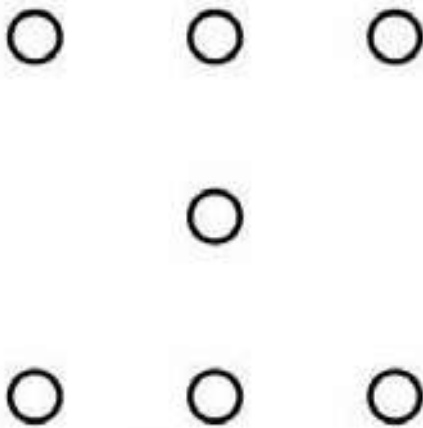

- Q82. How many triangles can you form by joining the above group of dots so that 3 dots are left?
(A) Six (B) Eight (C) Twelve (D) Twenty four
- Q83. How many quadrilaterals can you form by joining the above group of dots?
(A) Five (B) Six (C) Nine (D) Twelve

Questions 84 to 88 has more than one correct answer and carries 0.8 marks each. Please read the question carefully and select the most correct option (only one) from the options provided.

- Q84. Complete the sentence:
She was
(A) almost six feet tall. (B) the light of my life.
(C) a doctor by profession. (D) emotionally very vulnerable.
- Q85. Complete the sentence:
He was on a roller coaster.....
(A) ride at the fair. (B) of emotions.
(C) and he felt very scared. (D) with a group of friends.
- Q86. Complete the sentence:
Failure is.....
(A) very bad. No one should fail. (B) a representation of a person's abilities.
(C) a sad experience. Try again. (D) an orphan with no takers.
- Q87. Complete the sentence:
The Moon is
(A) of cultural importance. (B) like a roti for the poor man.
(C) a satellite of the earth. (D) a source of light at night.
- Q88. Complete the sentence:
Brain is
(A) a group of hundred billion cells. (B) a workshop.
(C) an important part of the human body. (D) a fountain of dreams.

***** End of Part I *****

ANSWER KEY FOR BOOKLET CODE 17 SERIES P [PART I]

Question No	Ans Key	Question No	Ans Key	Remarks
1	B	45	C	
2	A	46	D	
3	B	47	D	
4	B	48	C	
5	A	49	C	
6	A	50	D	
7	D	51	A	
8	D	52	B	
9	A	53	B	
10	B	54	D	
11	D	55	B&C	B&C BOTH THE OPTIONS ARE CORRECT.
12	D	56	C	
13	D	57	D	
14	C	58	A	
15	A	59	D	
16	A	60	C	
17	D	61	A&D	A&D BOTH THE OPTIONS ARE CORRECT.
18	B	62	C&D	C&D BOTH THE OPTIONS ARE CORRECT.
19	C	63	C	
20	B	64	B	
21	D	65	A	
22	B	66	A	
23	B	67	C	
24	C	68	B	
25	C	69	B	
26	C	70	C	
27	D	71	A	
28	B	72	B	
29	C	73	D	
30	C	74	C	
31	B	75	A	
32	C	76	D	
33	C	77	B	
34	C	78	B	
35	C	79	A	
36	C	80	C	
37	A	81	D	
38	D	82	B	
39	C	83	C	
40	D	84	B	B OPTION WILL GET 0.8, D OPTION WILL GET 0.4.
41	D	85	B	B OPTION WILL GET 0.8, C OPTION WILL GET 0.4.
42	C	86	D	D OPTION WILL GET 0.8, C OPTION WILL GET 0.4.
43	A	87	B	B OPTION WILL GET 0.8, A OPTION WILL GET 0.4.
44	B	88	D	D OPTION WILL GET 0.8, B OPTION WILL GET 0.4.



for uploading
on website

Amr

[Handwritten signature]

[Handwritten signature]



राष्ट्रीय डिजाइन संस्थान
NATIONAL INSTITUTE OF DESIGN

NID B.Des 2016 Original Paper Solved by NID Alumni

SILICA
YOUR DESIGN CAREER GUIDE

PART-II. Question numbers 89 to 91 carry 10 marks each. Please read the questions carefully and answer in the space provided.

Q89. The water tap of the wash basin in a bathroom is leaking. It is mid-night and no professional help is available at that hour. Give five ideas to prevent water wastage and represent them through drawings with two-three lines of explanation each.

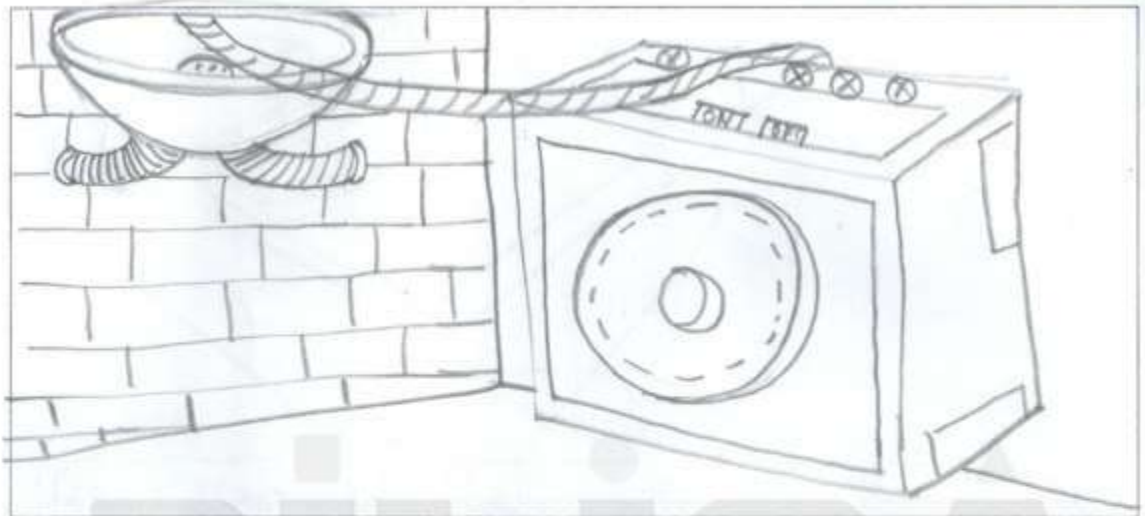

Connect the tap to a washing machine. Even if the tap is leaking the main pipe of machine won't take water till you turn on the power buttons of machine.



Connect the pipe to a bucket / tub & Refill the water for further daily routine uses.

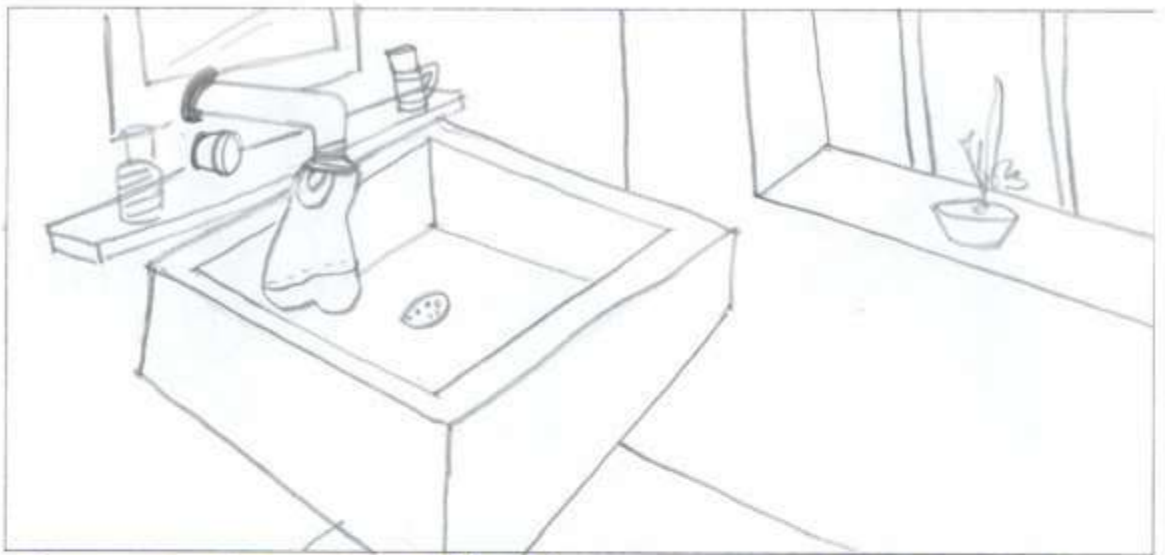

Use a plastic bag / balloon to cover the nozzle of the tap. It will take time to refill the Bag & won't make much sound. Tighten it up with Rubber bands.

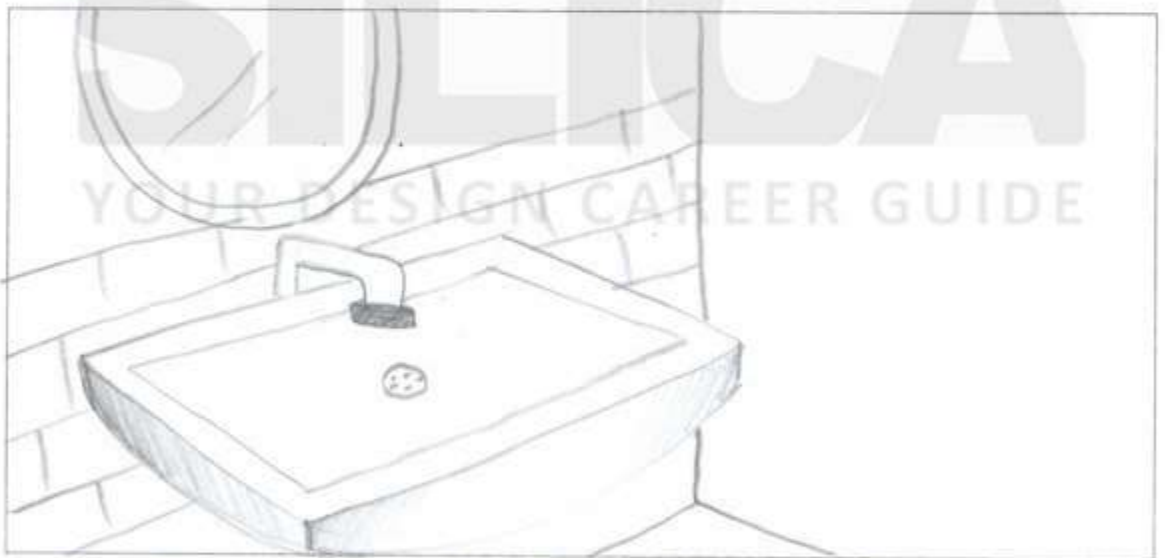

Use chewing gum to lock the nozzle temporarily. It can act as an adhesive material & can block the hole of the tap.

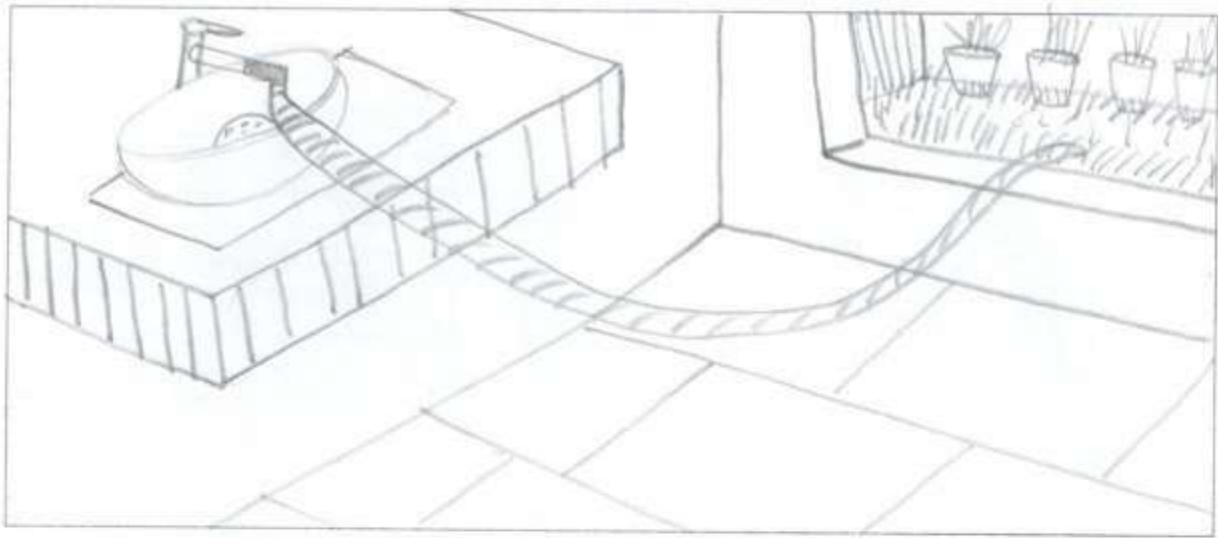

Use the same water for Gardening purpose, connecting a large pipe to nozzle towards the garden area.

GUIDELINES-

- Think of reusing the water at that hour.
- Think of temporary adhesives to fix the tap.
- Use background & foreground to depict the whole scenario.
- 3D drawing of tap & Basin is a necessity here.

Q90. "Once upon a time, monkeys had no long tails and elephants had very short trunks. Until *one day...*" Complete the story and represent the same in FIVE frames given below with a caption of not more than two lines for each frame.



Once upon a time, monkey had no longer tails & elephants had very short trunks. until one day it so happened that an elephant was climbing through a narrow passage which was along the edge of a cliff beside a river. that narrow passage was the only route to cliff which happened to be home for banana trees.



A monkey was sitting on top of a tree, which was alongside the narrow edge & was munching bananas, throwing peels the elephant; stepped & slipped on peel, not able to balance & was about to fall from the cliff onto river.



The monkey realised its mistake, ran towards the elephant, held his body & hind legs tightly over the trunk, & showed his tail towards elephant.



The elephant understanding the monkey's intention of helping him, held the small tail with her trunk & used it as a support preventing herself from being falling.

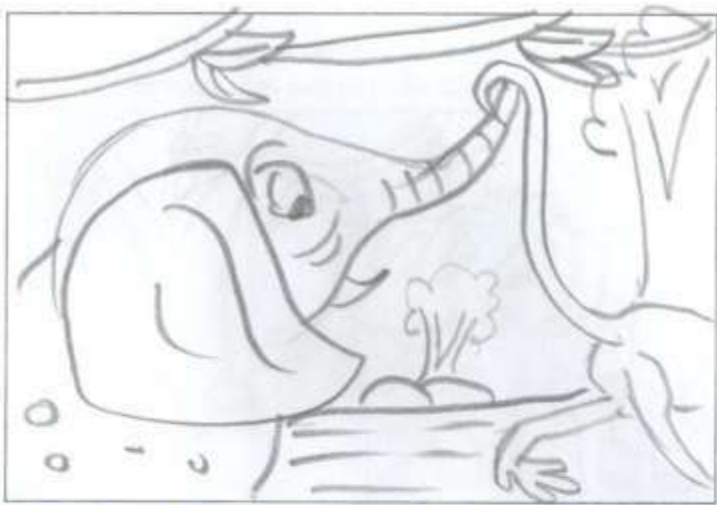

After the elephant climbed up the monkey's tail, the elephant realised that its trunk has enlarged till the ground. Monkey was happy. All the elephants held monkey tails & pulled over, helping in enlarging themselves.

GUIDELINES -

- Use the animated characters, if not good with proper realistic details.
- Think of a story which has a Plot & a climax.
- Introduce characters according to their personality.
- Add a twist & turn in the story to make it more interesting.

Q91. Choose one of the three topics given below. Design a poster in Black and White only on the chosen topic. Give a caption to your poster.

✓) Infant Mortality (ii) Rainwater harvesting (iii) Illiteracy

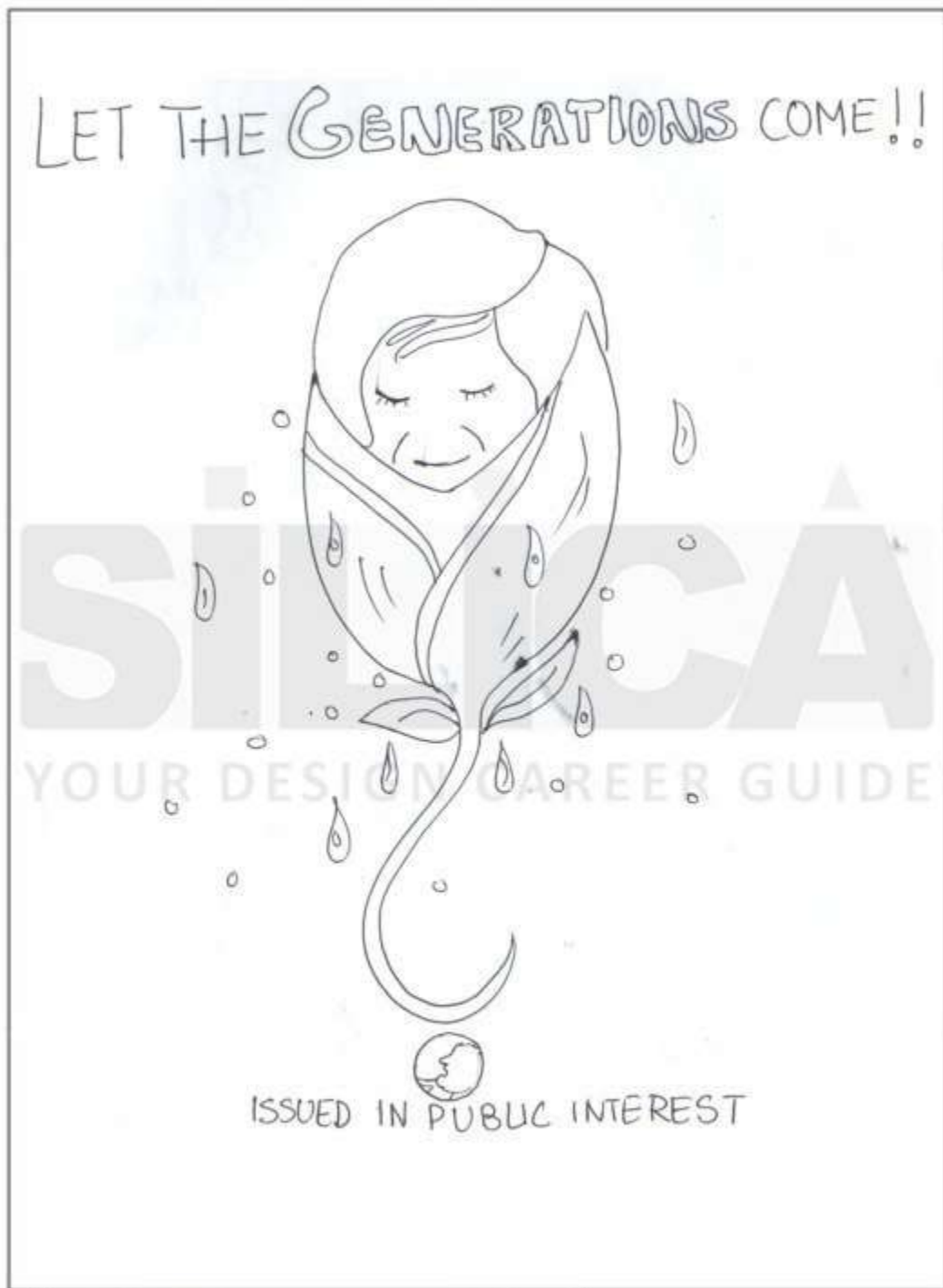

Caption "ABORTION IS CHILD MORTALITY"
***** End of Part II *****

Q91. Choose one of the three topics given below. Design a poster in Black and White only on the chosen topic. Give a caption to your poster.

(i) Infant Mortality (ii) Rainwater harvesting (iii) Illiteracy

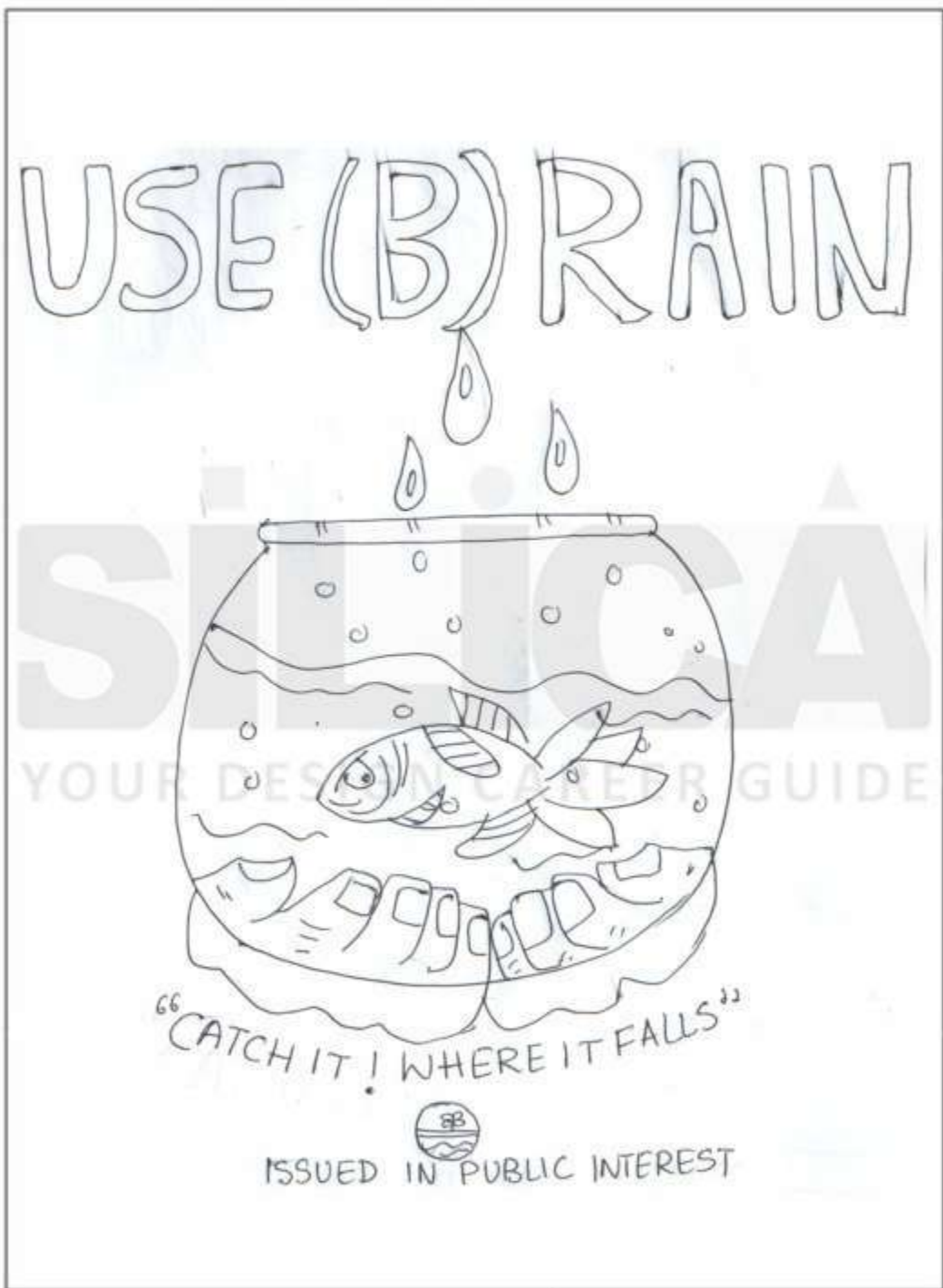

Caption SAVE EVERY DROP & BECOME SELF SUSTAINING

***** End of Part II *****

Q91. Choose one of the three topics given below. Design a poster in Black and White only on the chosen topic. Give a caption to your poster.

(i) Infant Mortality (ii) Rainwater harvesting (iii) Illiteracy



Caption GIVES RISE TO CHILD LABOUR - COMBAT ILLITERACY

***** End of Part II *****