

NEET 2016

OFFICIAL QUESTION PAPERS WITH DETAILED SOLUTION



All questions with detailed
solutions of Physics,
Chemistry and Biology

NEET 2016

Physics

Q. 1 A siren emitting a sound of frequency 800 Hz moves away from an observer towards a cliff at a speed of 15 ms^{-1} . Then, the frequency of sound that the observer hears in the echo reflected from the cliff is :

(Take velocity of sound in air = 330 ms^{-1})

Option 1:

765 Hz

Option 2:

800 Hz

Option 3:

838 Hz

Option 4:

885 Hz

Correct Answer:

838 Hz

Solution:

As we learnt in

Frequency of sound when observer is stationary and source is moving towards observer -

$$\nu' = \nu_0 \cdot \frac{C}{C - V_s}$$

- wherein

C = speed of sound

V_s = speed of source

ν_0 = original frequency

ν' = apparent frequency

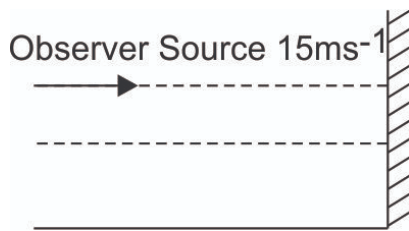

Apparent frequency,

$$\nu' = \frac{V}{V - V_s} \nu_0$$

$$= \frac{330}{330 - 15} \times 800 = 838\text{Hz}$$

Q. 2 Out of the following options which one can be used to produce a propagating electromagnetic wave?

Option 1:

A charge moving at constant velocity

Option 2:

A stationary charge

Option 3:

A chargeless particle

Option 4:

An accelerating charge

Correct Answer:

An accelerating charge

Solution:

Total radiant Flux (Power) -

$$P = \frac{q^2 a^2}{6\pi\epsilon_0 c^2}$$

The accelerated charge particle produces an EM wave. P is the total radiant flux emitted by charge at any instant.

Electromagnetic waves can be produced by an accelerating charge.

Hence, the answer is the option (4).

Q. 3 An inductor 20mH , a capacitor $50\mu\text{F}$ and a resistor 40Ω are connected in series across a source of emf $V = 10 \sin 340 t$. The power loss in the A.C. circuit :

Option 1:

0.51 W

Option 2:

0.67 W

Option 3:

0.76 W

Option 4:

0.89 W

Correct Answer:

0.51 W

Solution:

Impedance -

$$Z = \sqrt{R^2 + (X_L - X_c)^2}$$

Average power (True power)

$$P_{av} = V_{rms} i_{rms} \cos \phi$$

and

Power factor

$$\cos \phi = \frac{R}{Z}$$

wherein

$R \rightarrow$ resistance

$Z \rightarrow$ impedance

$$X_c = \frac{1}{\omega c} = \frac{1}{340 \times 50 \times 10^{-6}} = \frac{10^4}{34 \times 5} = 58.82 \Omega$$

$$X_L = \omega L = 340 \times 20 \times 10^{-3} = 6.8 \Omega$$

$$Z = \sqrt{R^2 + (X_L - X_c)^2} = \sqrt{(40)^2 + (58.82 - 6.8)^2}$$

$$Z = \sqrt{(40)^2 + (52.02)^2} = 65.62 \Omega$$

$$\text{Peak Current - } I_o = \frac{V_o}{z} = \frac{10}{65.62} A$$

$$\cos \phi = \frac{R}{Z} = \frac{40}{65.62}$$

$$\text{Power loss in A.C circuit} = P = V_{rms} I_{rms} \cos \phi = \frac{1}{2} V_o I_o \cos \phi$$

$$P = \frac{1}{2} \times 10 \times \frac{10}{65.62} \times \frac{40}{65.62} = 0.51W$$

Hence, the answer is the option (1).

Q. 4 Match the corresponding entries of column 1 with column 2 [where m is the magnification produced by the mirror]

Column 1	Column 2
(A) $m = -2$	(a) Convex mirror
(B) $m = -\frac{1}{2}$	(b) Concave mirror
(C) $m = +2$	(c) Real image
(D) $m = +\frac{1}{2}$	(d) Virtual image

Option 1:

A → b and c; B → b and c; C → b and d; D → a and d

Option 2:

A → a and c; B → a and d; C → a and b; D → c and d

Option 3:

A → a and d; B → b and c; C → b and d; D → b and c

Option 4:

A → c and d; B → b and d; C → b and c; D → a and d

Correct Answer:

A → b and c; B → b and c; C → b and d; D → a and d

Solution:

A → b and C

B → b and C

C → b and d

D → a and d

Magnification in the mirror, $m = -v/u$

$m = -2 \Rightarrow v = 2u$ As v and u have the same signs the mirror is concave and the image formed is real.

$m = -1/2 \Rightarrow v = u/2 \Rightarrow$ concave mirror and real Image.

$m = +2 \Rightarrow v = -2u$

As v and u have different signs but magnification is 2 the mirror is concave and the image formed is virtual.

$m = +1/2 \Rightarrow v = -u/2$

As v and u have different signs with magnification (1/2) the mirror is convex and the image formed is virtual.

Hence, the answer is the option (1).

Q. 5 The Coefficient of linear expansion of brass and steel rods is α_1 and α_2 . Lengths of brass and steel rods are l_1 and l_2 respectively. If $(l_2 - l_1)$ is maintained the same at all temperatures, which one of the following relations holds good?

Option 1:

$$\alpha_1 l_2 = \alpha_2 l_1$$

Option 2:

$$\alpha_1 l_2^2 = \alpha_2 l_1^2$$

Option 3:

$$\alpha_1^2 l_2 = \alpha_2^2 l_1$$

Option 4:

$$\alpha_1 l_1 = \alpha_2 l_2$$

Correct Answer:

$$\alpha_1 l_1 = \alpha_2 l_2$$

Solution:

Change in Length -

$$\Delta L = L_0(\alpha \Delta T)$$

wherein

$$\Delta L = L - L_0$$

$L - L_0 =$ Change in length

$$\Delta T = T - T_0$$

$T - T_0 =$ Change in temperature

$l_2 - l_1$ is maintained the same at all temperatures if $\Delta l_2 = \Delta l_1$

$$\Rightarrow l_2 \cdot \alpha_2 \Delta T = l_1 \alpha_1 \Delta T$$

$$\text{or } \Rightarrow l_1 \cdot \alpha_1 = l_2 \alpha_2$$

Hence, the answer is the option (4).

Q. 6 At what height from the surface of earth the gravitation potential and the value of 'g' are $-5.4 \times 10^7 \text{ J kg}^{-2}$ and 6.0 ms^{-2} respectively? Take the radius of earth as 6400 km:

Option 1:
2600 km

Option 2:
1600 km

Option 3:
1400 km

Option 4:
2000 km

Correct Answer:
2600 km

Solution:

As we learnt in

Potential due to Uniform solid sphere -

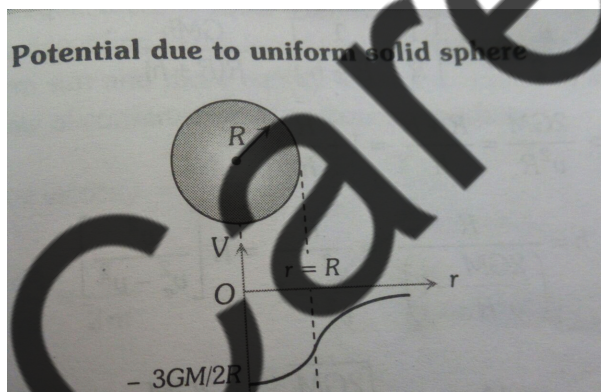

$R \rightarrow$ Radius of sphere

$M \rightarrow$ Mass of sphere

$r \rightarrow$ distance from centre of sphere

$$V_{\text{centre}} = \frac{3}{2} V_{\text{surface}}$$

- wherein

Outside the surface

$$V = -\frac{GM}{r}$$

on the surface

$$V_{surface} = -\frac{GM}{R}$$

Inside the surface

$$r < R$$

$$V = -\frac{GM}{2R} \left[3 - \left(\frac{r}{R} \right)^2 \right]$$

Gravitational potential at a height h , $V = \frac{-GM}{R+h}$ (1)

acceleration due to gravity at the height = h , $g' = \frac{GM}{(R+h)^2}$

or $\frac{|V|}{g'} = R+h$

or $\frac{5.4 \times 10^7}{6} = 6.4 \times 10^6 + h$

or $0.9 \times 10^7 = 6.4 \times 10^6 + h$

or $h = 2.6 \times 10^6 = 2600 \text{ km}$

Q. 7 A piece of ice falls from a height h so that it melts completely. Only one-quarter of the heat produced is absorbed by the ice and all the energy of ice gets converted into heat during its fall. The value of h is:

[Latent heat of ice is $3.4 \times 10^5 \text{ J/kg}$ and $g = 10 \text{ N/kg}$]

Option 1:

34 km

Option 2:

544 km

Option 3:

136 km

Option 4:

68 km

Correct Answer:

136 km

Solution:

Given that: $mgH = mL$

when heat is absorbed quarter then

$$\Rightarrow H = \frac{4L}{g} = \frac{4 \times 3.4 \times 10^5}{10} = 136 \text{ km}$$

Hence, the answer is the option (3).

Q. 8 In a diffraction pattern due to a single slit of width 'a', the first minimum is observed at an angle of 30° when light of wavelength 5000\AA is incident on the slit. The first secondary maximum is observed at an angle of:

Option 1:

$$\sin^{-1} \left(\frac{1}{4} \right)$$

Option 2:

$$\sin^{-1} \left(\frac{2}{3} \right)$$

Option 3:

$$\sin^{-1} \left(\frac{1}{2} \right)$$

Option 4:

$$\sin^{-1} \left(\frac{3}{4} \right)$$

Correct Answer:

$$\sin^{-1} \left(\frac{3}{4} \right)$$

Solution:

Fraunhofer Diffraction -

$$b \sin \theta = n\lambda$$

wherein

A condition of n^{th} minima.

$b =$ slit width

$\theta =$ angle of deviation

Hence, the answer is the option (4).

For the first minima; $b \sin \Theta = \lambda$

$$\sin \Theta = \frac{\lambda}{b}$$

$$\text{since } \Theta = 30^\circ \quad \lambda = \frac{b}{2}$$

For 1^{st} secondary maxima

$$b \sin \Theta' = \frac{3\lambda}{2}$$

$$2\lambda \sin \Theta' = \frac{3\lambda}{2}$$

$$\sin \Theta' = \frac{3}{4}$$

$$\Theta' = \sin^{-1} \left(\frac{3}{4} \right)$$

Hence, the answer is the option (4).

-
- Q. 9** A potentiometer wire is 100 cm long and a constant potential difference is maintained across it. Two cells are connected in series first to support one another and then in opposite direction. The balance points are obtained at 50 cm and 10 cm from the positive end of the wire in the two cases. The ratio of emf's is :

Option 1:

5 : 1

Option 2:

5 : 4

Option 3:

3 : 4

Option 4:

3 : 2

Correct Answer:

3 : 2

Solution:

Given that,

Length $l = 100$ cm

The emf when the two cells are connected in series then the balance point is 50 cm.

$$E_1 + E_2 = 50 \quad \dots(I)$$

The emf when the two cells are connected in opposite direction then the balance point is 10 cm.

$$E_1 - E_2 = 10 \quad \dots(II)$$

From equation (I) and (II)

Using elimination method we get,

$$E_1 = 30$$

$$E_2 = 20$$

Now, we will find the ratio of E_1 and E_2

$$\frac{E_1}{E_2} = \frac{3}{2}$$

Q. 10 A particle of mass 10 g moves along a circle of radius 6.4 cm with a constant tangential acceleration. What is the magnitude of this acceleration if the kinetic energy of the particle becomes equal to 8×10^{-4} J by the end of the second revolution after the beginning of the motion?

Option 1:

$$0.1 \text{ m/s}^2$$

Option 2:

$$0.15 \text{ m/s}^2$$

Option 3:

$$0.18 \text{ m/s}^2$$

Option 4:

$$0.2 \text{ m/s}^2$$

Correct Answer:

$$0.1 \text{ m/s}^2$$

Solution:

$$KE = \frac{1}{2}mV^2 = 8 * 10^{-4}J$$

$$V^2 = 16 * 10^{-2}$$

$$V^2 = 2a_t s$$

$$\frac{V^2}{8\pi r} = a_t$$

$$a_t = \frac{16 \times 10^{-2}}{8 \times 3.14 \times 6.4 \times 10^{-2}} = 0.1 m/s^2$$

Hence, the answer is the option (1).

Q. 11 An air column, closed at one end and open at the other, resonates with a tuning fork when the smallest length of the column is 50 cm. The next larger length of the column resonating with the same tuning fork is:

Option 1:
66.7 cm

Option 2:
100 cm

Option 3:
150 cm

Option 4:
200 cm

Correct Answer:
150 cm

Solution:

Condition of constructive interference

$$l = (2n + 1) \frac{\lambda}{4}$$

For a closed organ pipe first minimum resonating length

$$L_1 = \frac{\lambda}{4} = 50 \text{ cm}$$

Next or second resonating length L_2

$$L_2 = \frac{3\lambda}{4} = 150 \text{ cm}$$

Hence, the answer is the option (3).

Q. 12 To get output 1 for the following circuit, the correct choice for the input is

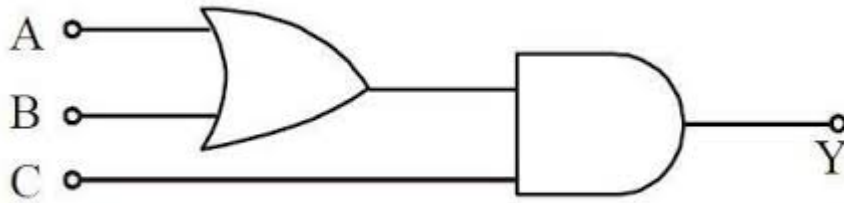

Option 1:

A=0, B=1, C=0

Option 2:

A=1, B=0, C=0

Option 3:

A=1, B=1, C=0

Option 4:

A=1, B=0, C=1

Correct Answer:

A=1, B=0, C=1

Solution:

OR gate -

The relation between input and output

$$Y = A + B$$



- wherein

A and B are input

Y is out put

AND Gate -

$$Y = A \cdot B$$

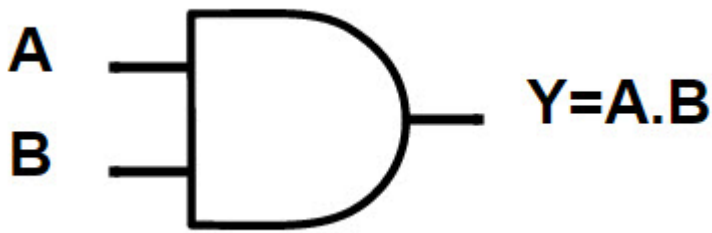

- wherein

A and B are input

Y is output

Output of the given circuit is

$$Y = (A+B).C$$

From left side the first gate is OR gate and next one is AND gate. So the output of OR gate is $A+B$ and the output of AND gate $Y=(A+B).C$

We know that for AND gate the output will be 1 if both inputs are 1. So, $A+B=1$ and $C=1$

In logic gate, $1+0=1$ so $A=1, B=0, C=1$ will be the correct choice.

Q. 13 A gas is compressed isothermally to half its initial volume. The same gas is compressed separately through and adiabatic process until its volume is again reduced to half. Then:

Option 1:

Compressing the gas isothermally will require more work to be done.

Option 2:

Compressing the gas through adiabatic process will require more work to be done.

Option 3:

Compressing the gas isothermally or adiabatically will require the same amount of work.

Option 4:

Which of the case (whether compression through isothermal or through adiabatic process) requires more work will depend upon the atomicity of the gas.

Correct Answer:

Compressing the gas through adiabatic process will require more work to be done.

Solution:

As we learnt in

Comparison between isothermal and adiabatic process in compression -

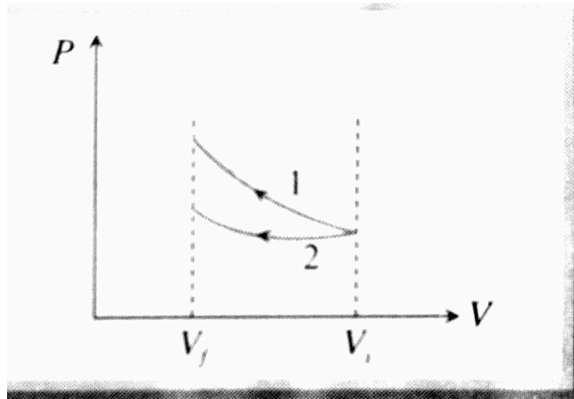

- wherein

$$\omega_{adia} > \omega_{isothermal}$$

$$P_{adia} > P_{isothermal}$$

$$T_{adia} > T_{isothermal}$$

Consider the P-V indicator diagram shown below

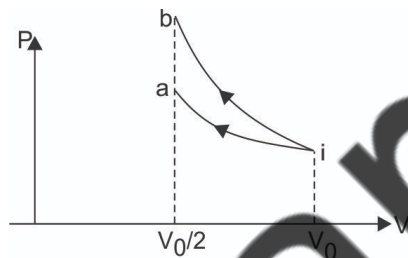

$ia \rightarrow$ Isothermal process

$ib \rightarrow$ Adiabatic process

Since slope of adiabatic process is greater than slope of isothermal process.

Work done under adiabatic process is greater than work done under isothermal process as area under ib is greater than area under ia .

- Q. 14** The intensity at the maximum in a Young's double slit experiment is I_0 . Distance between two slits of $d = 5\lambda$, where λ is the wavelength of light used in the experiment. What will be the intensity in front of one of the slits on the screen placed at a distance $D = 10d$?

Option 1:

Blank Equation I_0

Option 2:

$$\frac{I_0}{4}$$

Option 3:

$$\frac{3}{4}I_0$$

Option 4:

$$\frac{I_0}{2}$$

Correct Answer:

$$\frac{I_0}{2}$$

Solution:

$$d = 5\lambda$$

$$D = 10d = 50\lambda$$

$$y = (\Delta x) \cdot \frac{D}{d}$$

For position in front of slit

$$y = \frac{d}{2} = (\Delta x) \frac{D}{d}$$

$$\text{or } \Delta x = \frac{d^2}{2D} = \frac{25\lambda^2}{2 \cdot (50\lambda)}$$

$$\Delta x = \frac{\lambda}{4}$$

$$\text{path diff} = \frac{\lambda}{4}$$

$$= \text{phase difference} = \left(\frac{2\pi}{\lambda}\right) \cdot \frac{\lambda}{4} = \frac{\pi}{2}$$

If Intensity of any one slit is I

$$\text{Then } I_R = I + I + 2\sqrt{I \cdot I} \cdot \cos \frac{\pi}{2}$$

$$I_R = I_0 = (\sqrt{I} + \sqrt{I})^2 - 4I$$

$$\therefore I_R = \frac{I_0}{2}$$

Q. 15 A car is negotiating a curved road of radius R . The road is banked at an angle θ . The coefficient of friction between the types of the car and the road is μ_s . The maximum safe velocity on this road is:

Option 1:

$$\sqrt{gR^2 \frac{\mu_s + \tan\theta}{1 - \mu_s \tan\theta}}$$

Option 2:

$$\sqrt{gR \frac{\mu_s + \tan\theta}{1 - \mu_s \tan\theta}}$$

Option 3:

$$\sqrt{\frac{g}{R} \frac{\mu_s + \tan\theta}{1 - \mu_s \tan\theta}}$$

Option 4:

$$\sqrt{\frac{g}{R^2} \frac{\mu_s + \tan\theta}{1 - \mu_s \tan\theta}}$$

Correct Answer:

$$\sqrt{gR \frac{\mu_s + \tan\theta}{1 - \mu_s \tan\theta}}$$

Solution:

As we learnt in

If friction is also present in banking of road -

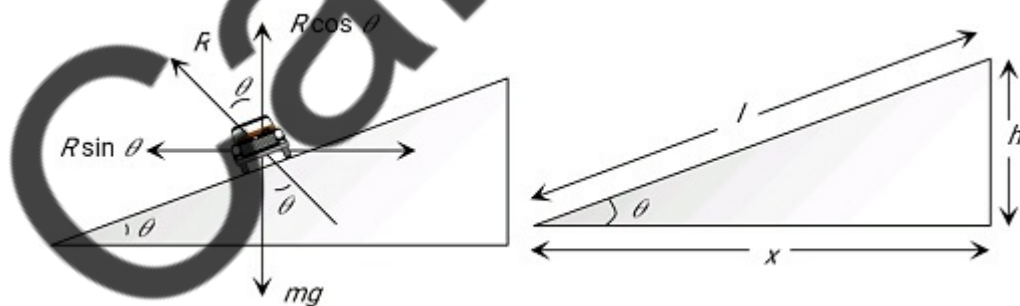

$$\frac{V^2}{rg} = \frac{\mu + \tan\theta}{1 - \mu \tan\theta}$$

θ = angle of banking

μ = coefficient of friction

V = velocity

- wherein

Maximum speed on a banked frictional road

$$V = \sqrt{\frac{rg(\mu + \tan\theta)}{1 - \mu\tan\theta}}$$

$$V = \sqrt{Rg \frac{\tan\theta + \mu_s}{1 - \mu_s \tan\theta}}$$

Q. 16 An electron of mass m and a photon have the same energy E . The ratio of de-Broglie wavelengths associated with them is (C being the velocity of light):

Option 1:

$$\frac{1}{c} \left(\frac{E}{2m} \right)^{\frac{1}{2}}$$

Option 2:

$$\left(\frac{E}{2m} \right)^{\frac{1}{2}}$$

Option 3:

$$c(2mE)^{\frac{1}{2}}$$

Option 4:

$$\frac{1}{c} \left(\frac{2m}{E} \right)^{\frac{1}{2}}$$

Correct Answer:

$$\frac{1}{c} \left(\frac{E}{2m} \right)^{\frac{1}{2}}$$

Solution:

De - Broglie wavelength -

$$\lambda = \frac{h}{p} = \frac{h}{mv} = \frac{h}{\sqrt{2mE}}$$

For a photon $E = \frac{hc}{\lambda_p}$

or $\lambda_p = \frac{hc}{E}$ (i)

$$\text{For electron } \lambda_e = \frac{h}{p} = \frac{h}{\sqrt{2mE}}$$

$$\lambda_e = \frac{h}{\sqrt{2mE}} \quad \dots(2)$$

$$\frac{\lambda_e}{\lambda_p} = \frac{h}{\sqrt{2mE} \cdot \frac{hC}{E}} = \frac{1}{C} \cdot \sqrt{\frac{E}{2m}}$$

Hence, the answer is the option (1).

Q. 17 A black body is at a temperature of 5760 K. The energy of radiation emitted by the body at wavelength 250 nm is U_1 , at wavelength 500 nm is U_2 and that at 1000 nm is U_3 . Wien's constant, $b = 2.88 \times 10^6 \text{ nmK}$. Which of the following is **correct**?

Option 1:

$$U_1 = 0$$

Option 2:

$$U_3 = 0$$

Option 3:

$$U_1 > U_2$$

Option 4:

$$U_2 > U_1$$

Correct Answer:

$$U_2 > U_1$$

Solution:

As we learnt in

Stefan's Law -

Radiant energy emitted by a perfectly black body per unit area per sec is directly proportional to 4th power of temperature of the body.

$$\lambda_m T = b$$

$$\lambda_m = \frac{2.88 \times 10^6 \text{ nmK}}{5760} K = 500 \text{ nm}$$

Hence energy radiated at 500nm is maximum

$$U_1 < U_2 > U_3$$

Q. 18 Given the value of the Rydberg constant is 10^7 m^{-1} , the wave number of the last line of the Balmer series in the hydrogen spectrum will be:

Option 1:

$$0.025 \times 10^4 \text{ m}^{-1}$$

Option 2:

$$0.5 \times 10^7 \text{ m}^{-1}$$

Option 3:

$$0.25 \times 10^7 \text{ m}^{-1}$$

Option 4:

$$2.5 \times 10^7 \text{ m}^{-1}$$

Correct Answer:

$$0.25 \times 10^7 \text{ m}^{-1}$$

Solution:

Balmer series -

$$\frac{1}{\lambda} = R \left(\frac{1}{2^2} - \frac{1}{n^2} \right)$$

(*visible light*)

wherein

$$n = 3, 4, 5 \dots$$

When an electron jumps from a higher orbital to an $n=2$ energy level

Balmer series $n \rightarrow 2$

the last line of the Balmer series means when e^- jumping from infinity $\rightarrow 2$

$$\therefore \frac{1}{\lambda} = R \left(\frac{1}{4} - \frac{1}{\infty} \right) = \frac{R}{4}$$

$$\text{Wave number} = \frac{1}{\lambda} = \frac{R}{4}$$

$$= 0.25 \times 10^7 \text{ m}^{-1}$$

Hence, the answer is the option (3).

Q. 19 A npn transistor is connected in common emitter configuration in a given amplifier. A load resistance of 800Ω is connected in the collector circuit and the voltage drop across it is 0.8 V . If the current amplification factor is 0.96 and the input resistance of the circuit is 192Ω , the voltage gain and the power gain of the amplifier will respectively be:

Option 1:

4, 3.84

Option 2:

3.69, 3.84

Option 3:

4, 4

Option 4:

4, 3.69

Correct Answer:

4, 3.84

Solution:

As we learnt in

Transistor -

Three layered semiconducting device .

NPN or PNP

- wherein

1. Emitter is heavily doped
2. collector is moderately doped .
3. Base is lightly doped & very thin

$$R_L = 800\Omega$$

$$V_L = 0.8\text{V}$$

Current amplification = 0.96

$$R_i = 192\Omega$$

$$\text{Voltage gain} = \frac{V_0}{V_i} = \beta \cdot \frac{R_L}{R_i}$$

$$= 0.96 \times \left(\frac{800}{192} \right) = 4$$

$$\text{Power gain} = \beta^2 \left(\frac{R_L}{R_i} \right)$$

$$= 0.96 \times 0.96 \times \frac{800}{192}$$

$$= 0.96 \times \frac{96 \times 8}{192} = 3.84$$

Q. 20 Two non-mixing liquids of densities ρ and $n\rho$ ($n > 1$) are put in a container. The height of each liquids is h . A solid cylinder of length L and density d is put in this container. The cylinder floats with its axis vertical and length pL ($p < 1$) in the denser liquids. The density d is equal to :

Option 1:

$$\{1 + (n + 1)p\} \rho$$

Option 2:

$$\{2 + (n + 1)p\} \rho$$

Option 3:

$$\{2 + (n - 1)p\} \rho$$

Option 4:

$$\{1 + (n - 1)p\} \rho$$

Correct Answer:

$$\{1 + (n - 1)p\} \rho$$

Solution:

At equilibrium

weight of cylinder = Force of Buoyancy

$$(d \cdot LA)g = B_1 + B_2$$

$$= \rho(L - pL)Ag + n\rho ApLg$$

$$\alpha = \rho(1 - p) + (n\rho) p$$

$$\alpha = \rho[1 + (n - 1)p]$$

Hence, the answer is the option (4).

Q. 21 If the velocity of a particle is $v = At + Bt^2$, where A and B are constants, then the distance travelled by it between 1s and 2s is:

Option 1:

$$\frac{3}{2}A + 4B$$

Option 2:

$$3A + 7B$$

Option 3:

$$\frac{3}{2}A + \frac{7}{3}B$$

Option 4:

$$\frac{A}{2} + \frac{B}{3}$$

Correct Answer:

$$\frac{3}{2}A + \frac{7}{3}B$$

Solution:

As we learnt in

Introduction to Differentiation -

$$\frac{d}{dx}(x^n) = nx^{n-1}$$

- wherein

$$\frac{d}{dx}(x^5) = (n = 5)$$

$$\Rightarrow nx^{n-1}$$

$$\Rightarrow 5x^{5-1}$$

$$\Rightarrow 5x^4$$

$$v = At + Bt^2$$

$$\frac{dx}{dt} = (At + Bt^2) \Rightarrow dx = (At + Bt^2) dt$$

$$\int_{x_1}^{x_2} dx = \int_1^2 (At + Bt^2) dt$$

$$\Delta x = x_2 - x_1$$

$$(x_2 - x_1) = A \int_1^2 t \cdot dt + B \int_1^2 t^2 \cdot dt$$

$$\begin{aligned} x_2 - x_1 &= \frac{A}{2} (2^2 - 1^2) + \frac{B}{3} (2^3 - 1^3) \\ &= \frac{3}{2}A + \frac{7}{3}B \end{aligned}$$

Q. 22 A astronomical telescope has objective and eyepiece of focal lengths 40 cm and 4 cm respectively. To view an object 200 cm away from the objective, the lenses must be separated by a distance :

Option 1:
37.3 cm

Option 2:
46.0 cm

Option 3:
50.0 cm

Option 4:
54.0 cm

Correct Answer:
54.0 cm

Solution:

As we learnt in

Astronomical Telescope -

$$m = \frac{-f_o}{f_e} \left(1 + \frac{f_e}{D} \right)$$

- wherein

f_o = focal length of objective

f_e = focal length of eyepiece

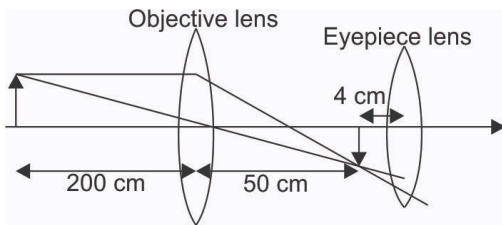

For astronomical telescope

$$f_o = 40\text{cm}, \quad f_e = 4\text{cm}$$

Object distance for objective lens

$$u_o = -200\text{cm}$$

For 1st image : $u_o = -200$, $f_o = 40\text{cm}$

$$\therefore \frac{1}{v_o} - \frac{1}{u_o} = \frac{1}{f_o} \quad \text{or} \quad \frac{1}{v_o} = \frac{1}{f_o} + \frac{1}{u_o}$$

$$\text{or} \quad \frac{1}{v_o} = \frac{1}{40} - \frac{1}{200} = \frac{4}{200}$$

$$v_o = 50\text{cm}.$$

Since image will form at focal point of eyepiece, hence distance of this image from eyepiece = 4 cm

Hence distance between objective and eyepiece = $(50+4)$ cm = 54 cm

Q. 23 The ratio of the escape velocity of Earth (v_e) to the escape velocity at a planet (v_p) whose radius and mean density are twice that of Earth is:

Option 1:

1 : 2

Option 2:

1 : $2\sqrt{2}$

Option 3:

1 : 4

Option 4:

1 : $\sqrt{2}$

Correct Answer:

1 : $2\sqrt{2}$

Solution:

Escape velocity (in terms of the radius of a planet) -

$$V_c = \sqrt{\frac{2GM}{R}}$$

$$V_c = \sqrt{2gR}$$

$V_c \rightarrow$ Escape velocity

$R \rightarrow$ Radius of earth

- wherein

- depends on the reference body
- greater the value of $\frac{M}{R}$ or (gR) greater will be the escape velocity $V_e = 11.2 \text{ Km/s}$. For earth

$$\text{escape velocity} = \frac{\sqrt{2GM}}{R}$$

$$\frac{\sqrt{2G \cdot (\rho \cdot \frac{4\pi}{3} R^3)}}{R} = \sqrt{\frac{8\pi}{3} G \rho R^2}$$

$$\frac{V_p}{V_e} = \frac{\sqrt{\rho_p \cdot R_p^2}}{\sqrt{\rho_e \cdot R_e^2}} = 2\sqrt{2}$$

$$\frac{V_e}{V_p} = \frac{1}{2\sqrt{2}}$$

Hence, the answer is the option (2).

- Q. 24** A long straight wire of radius a carries a steady current I . The current is uniformly distributed over its cross-section. The ratio of the magnetic fields B and B' , at radial distances $\frac{a}{2}$ and $2a$ respectively, from the axis of the wire is:

Option 1:

$$\frac{1}{4}$$

Option 2:

$$\frac{1}{2}$$

Option 3:

$$1$$

Option 4:

$$4$$

Correct Answer:

1

Solution:

As we learnt in

For Infinite Length -

$$\phi_1 = \phi_2 = 90^\circ$$

$$B = \frac{\mu_o}{4\pi} \frac{2i}{r}$$

- wherein

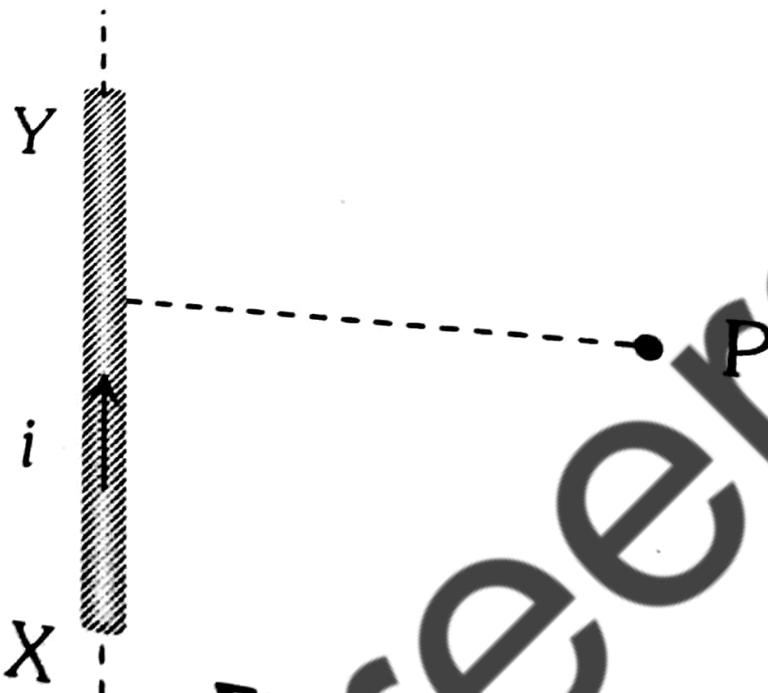

Magnetic field at a point inside the wire at a distance $r = \frac{a}{2}$ from the axis of wire is

$$B = \frac{\mu_o I}{2\pi a^2} r = \frac{\mu_o I}{2\pi a^2} \frac{a}{2} = \frac{\mu_o I}{4\pi a}$$

Magnetic field at a point outside the wire at distance $r=2a$ from the axis of wire is

$$B' = \frac{\mu_o I}{2\pi r} = \frac{\mu_o I}{2\pi \cdot 2a} = \frac{\mu_o I}{4\pi a}$$

$$\therefore \frac{B}{B'} = 1$$

Q. 25

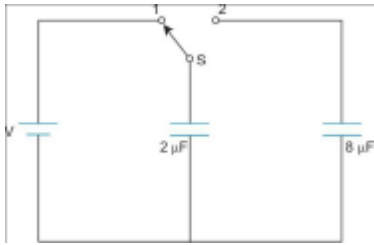

A capacitor of $2\mu\text{F}$ is charged as shown in the diagram. When the switch S is turned to position 2, the percentage of its stored energy dissipated is:

Option 1:

0%

Option 2:

20%

Option 3:

75%

Option 4:

80%

Correct Answer:

80%

Solution:

As we learnt in

Loss of Energy -

$$\Delta U = U_i - U_f = \frac{C_1 C_2}{2(C_1 + C_2)} (V_1 - V_2)^2$$

-

Energy Stored -

$$U = \frac{1}{2}CV^2 = \frac{1}{2}QV = \frac{Q^2}{2C}$$

-

When s and 1 are connected the $2\mu\text{F}$ capacitor gets charged

$$u_i = \frac{1}{2}cv^2 = \frac{1}{2} \times 2 \times v^2 = v^2$$

when 5 and 2 are connected the $8\mu F$ capacitor also gets charged the energy loss Δu

$$\Delta u = \frac{1}{2} \frac{c_1 c_2}{c_1 + c_2} (v_1 - v_2)^2$$

$$c_1 = 2\mu F$$

$$c_2 = 8\mu F$$

$$v_1 = v, \quad v_2 = 0$$

$$\therefore \Delta u = \frac{1}{2} \times \frac{2 \times 8}{2 + 8} (v - 0)^2 = \frac{4}{5}v^2$$

$$\text{Percentage of energy dissipated} = \frac{\Delta u}{u_i} \times 100 = \frac{\frac{4}{5}v^2}{v^2} \times 100 = 80\%$$

Q. 26 When a metallic surface is illuminated with radiation of wavelength λ , the stopping potential is V . If the same surface is illuminated with radiation of wavelength 2λ , the stopping potential is $\frac{V}{4}$. The threshold wavelength for the metallic surface is:

Option 1:

$$4\lambda$$

Option 2:

$$5\lambda$$

Option 3:

$$\frac{5}{2}\lambda$$

Option 4:

$$3\lambda$$

Correct Answer:

$$3\lambda$$

Solution:

As we learnt in

Conservation of energy -

$$h\nu = \phi_0 + \frac{1}{2}mv_{max}^2$$

$$h\nu = h\nu_0 + \frac{1}{2}mv_{max}^2$$

$$h(\nu - \nu_0) = \frac{1}{2}mv_{max}^2$$

where e, h – Planck's constant ν – Frequency ν_0 – threshold frequency ϕ_0 – work function

- wherein

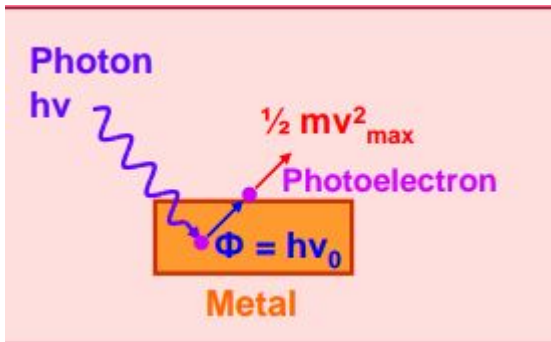

Let threshold wavelength is λ_0

$$\text{Then } eV = \frac{hc}{\lambda} - \frac{hc}{\lambda_0} \text{-----(1)}$$

$$\frac{ev}{4} = \frac{hc}{2\lambda} - \frac{hc}{\lambda_0} \text{-----(2) } \times 4$$

$$\Rightarrow eV = \frac{2hc}{\lambda} - \frac{4hc}{\lambda_0} \text{-----(3)}$$

From equation (1) and (3)

$$\frac{2hc}{\lambda} - \frac{4hc}{\lambda_0} = \frac{hc}{\lambda} - \frac{hc}{\lambda_0}$$

or

$$\frac{hc}{\lambda_0} = \frac{3hc}{\lambda_0} \text{ or } \lambda_0 = 3\lambda$$

Q. 27 If the magnitude of sum of two vectors is equal to the magnitude of difference of the two vectors, the angle between these vectors is:

Option 1:

0°

Option 2:

90°

Option 3:

45°

Option 4:

180°

Correct Answer:

90°

Solution:

As we learnt in

Parallelogram law of vector Addition -

If two vector are represented by both magnitude and direction by two adjacent side of parallelogram taken from same point then their resultant is also represented by both magnitude and direction taken from same point but by diagonal of parallelogram.

- wherein

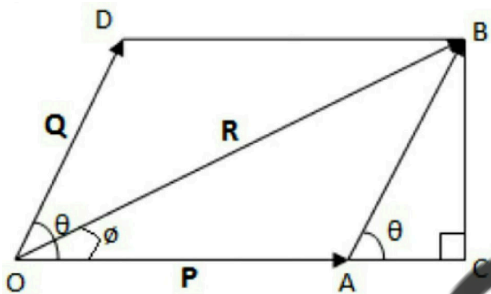

Represents law of parallelogram vector Addition

$$|\vec{A} - \vec{B}| = |\vec{A} + \vec{B}|$$

$$A^2 + B^2 - 2AB\cos\theta = A^2 + B^2 + 2AB\cos\theta$$

$$4AB\cos\theta = 0$$

$$\cos\theta = \frac{0}{4AB} = 0 = 90^\circ$$

Q. 28 A body of mass 1 kg begins to move under the action of a time-dependent force $F = (2t\hat{i} + 3t^2\hat{j})$ N, where \hat{i} and \hat{j} are unit vectors along the x-axis and y-axis. What power will be developed by the force at the time t?

Option 1:
($2t^2 + 3t^3$) W

Option 2:
($2t^2 + 4t^4$) W

Option 3:
($2t^3 + 3t^4$) W

Option 4:
($2t^3 + 3t^5$) W

Correct Answer:
($2t^3 + 3t^5$) W

Solution:

Power if the force is constant -

$$P = \frac{dw}{dt} = P = \vec{F} \cdot \vec{v}$$

- wherein

$\vec{F} \rightarrow$ force

$\vec{v} \rightarrow$ velocity

we know that

$$f = \frac{dp}{dt} = m \frac{dv}{dt}$$

$$2 + \hat{i} + 3t^2\hat{j} = m \frac{dv}{dt}$$

$$\Rightarrow \int_0^{\vec{v}} d\vec{v} = \int_0^t (2t\hat{i} + 3t^2\hat{j}) dt$$

$$\therefore \vec{v} = t^2\hat{i} + t^3\hat{j}$$

$$\vec{P} = \vec{F} \cdot \vec{V}$$

$$= (2t\hat{i} + 3t^2\hat{j}) \cdot (t^2\hat{i} + t^3\hat{j})$$

$$= (2t^3 + 3t^5) w$$

Hence, the answer is the option (4).

Q. 29 The angle of incidence for a ray of light at a refracting surface of a prism is 45° . The angle of the prism is 60° . If the ray suffers minimum deviation through the prism, the angle of minimum deviation and refractive index of the material of the prism respectively, are:

Option 1:

$$45^\circ; \frac{1}{\sqrt{2}}$$

Option 2:

$$30^\circ; \sqrt{2}$$

Option 3:

$$45^\circ; \sqrt{2}$$

Option 4:

$$30^\circ; \frac{1}{\sqrt{2}}$$

Correct Answer:

$$30^\circ; \sqrt{2}$$

Solution:

Condition of maximum deviation -

$$i = e$$

wherein

$$\delta_{min} = 2i - A$$

$$\mu = \frac{\sin\left(\frac{\delta_{min} + A}{2}\right)}{\sin(A/2)}$$

$$i = 45^\circ$$

$$A = 60^\circ$$

for minimum deviation

$$i = e = 45^\circ$$

$$r_1 = r_2 = \frac{A}{2}$$

$$\delta_{min} = 2i - A$$

$$= 90^\circ - 60^\circ = 30^\circ$$

$$\mu = \frac{\sin\left(\frac{A+\delta m}{2}\right)}{\sin\left(\frac{A}{2}\right)}$$

$$\mu = \frac{\sin\left(\frac{60+30}{2}\right)}{\sin\left(\frac{A}{2}\right)} = \frac{\sin 45^\circ}{\sin 30^\circ}$$

$$\mu = \sqrt{2}$$

Hence, the answer is the option (2).

Q. 30 A particle moves so that its position vector is given by $\vec{r} = \cos \omega t \hat{x} + \sin \omega t \hat{y}$. Where ω is a constant.

Which of the following is true?

Option 1:

Velocity and acceleration both are perpendicular to \vec{r} .

Option 2:

Velocity and acceleration both are parallel to \vec{r} .

Option 3:

Velocity is perpendicular to \vec{r} and acceleration is directed towards the origin.

Option 4:

Velocity is perpendicular to \vec{r} and acceleration is directed away from the origin.

Correct Answer:

Velocity is perpendicular to \vec{r} and acceleration is directed towards the origin.

Solution:

As we learnt in

Vector or cross product -

Vector or cross product of two vector \vec{A} & \vec{B} written as $\vec{A} \times \vec{B}$ is a single vector whose magnitude is equal to product of magnitude of \vec{A} & \vec{B} and the sine of smaller angle Θ between them.

$$\vec{A} \times \vec{B} = AB \sin \Theta$$

- wherein

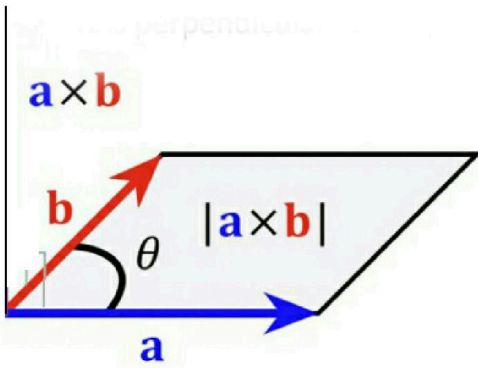

Figure 6 shows representation of vector or cross product of vectors.

shows representation of vector or cross product of vectors

$$\vec{r} = \cos wt \hat{i} + \sin wt \hat{j}$$

For two perpendicular vectors

$$\vec{V} \cdot \vec{r} = 0$$

$$\frac{dr}{dt} = V \Rightarrow V = -w (\sin wt \hat{i} - \cos wt \hat{j})$$

$$\text{and } \vec{V} \cdot \vec{r} = 0$$

So, velocity is \perp to r and \vec{a} is directed towards the origin.

Correct option is 3.

Q. 31 Consider the junction diode as ideal. The value of current flowing through AB is:

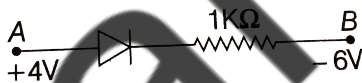

Option 1:

0 A

Option 2:

10^{-2} A

Option 3:

10^{-1} A

Option 4:

10^{-3} A

Correct Answer:

$$10^{-2} \text{ A}$$

Solution:

P-N junction as diode -

It is a one way device. It offers a low resistance when forward biased and high resistance when reverse biased.

- wherein

$R = 0$, Forward

$R \rightarrow \infty$ Reverse

The potential difference = 10V

since diode is ideal and it is in forward biased mode it will not offer resistance

$$\begin{aligned} \therefore \Delta V_{AB} &= 10V \\ R &= 1K\Omega \\ I &= \frac{10V}{1K\Omega} = 10^{-2}A \end{aligned}$$

Q. 32 Two identical charged spheres suspended from a common point by two massless strings of lengths l , are initially at a distance d ($d \ll l$) apart because of their mutual repulsion. The charges begin to leak from the both the spheres at a constant rate. As a result, the spheres approach each other with a velocity v . Then v varies as a function of the distance x between the spheres as:

Option 1:

$$v \propto x^{\frac{1}{2}}$$

Option 2:

$$v \propto x$$

Option 3:

$$v \propto x^{-\frac{1}{2}}$$

Option 4:

$$v \propto x^{-1}$$

Correct Answer:

$$v \propto x^{-\frac{1}{2}}$$

Solution:

As we learnt in

Coulombic force -

$$F \propto Q_1 Q_2 = F \propto \frac{Q_1 Q_2}{r^2} = F = \frac{K Q_1 Q_2}{r^2}$$

- wherein

K - proportionality Constant

Q_1 and Q_2 are two Point charge

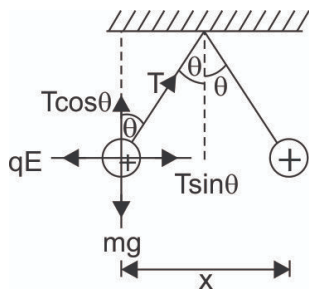

$$T \cos \Theta = mg \quad - (i)$$

$$T \sin \Theta = qE \quad - (ii)$$

$$\tan \Theta = \frac{qE}{mg} = \frac{Kq^2}{x^2 mg}$$

$$\frac{x}{2l} = \frac{Kq^2}{x^2 mg} \Rightarrow q^2 = \frac{x^3 mg}{2lK} \text{ or } q \propto x^{\frac{3}{2}}$$

$$\frac{dq}{dt} \propto \frac{3}{2} \sqrt{x} \frac{dx}{dt} = \frac{3}{2} \sqrt{x} v$$

Where $\frac{dq}{dt} = \text{constant}$

$$\therefore V \propto \frac{1}{\sqrt{x}} \Rightarrow V \propto x^{-\frac{1}{2}}$$

Q. 33 A small signal voltage $V(t) = V_0 \sin \omega t$ is applied across an ideal capacitor C:

Option 1:

Current $I(t)$, lags voltage $V(t)$ by 90° .

Option 2:

Over a full cycle, the capacitor C does not consume any energy from the voltage source.

Option 3:

Current $I(t)$ is in phase with voltage $V(t)$.

Option 4:

Current $I(t)$ leads voltage $V(t)$ by 180° .

Correct Answer:

Over a full cycle, the capacitor C does not consume any energy from the voltage source.

Solution:

When an ideal capacitor is connected to an AC voltage source, the current leads voltage by 90° . Since energy stored in the capacitor during charging is spent in maintaining charge on the capacitor during discharging. Hence over a full cycle, the capacitor does not consume any energy from the voltage source.

Hence, the answer is the option (2).

Q. 34 The magnetic susceptibility is negative for:

Option 1:

diamagnetic material only

Option 2:

paramagnetic material only

Option 3:

ferromagnetic material only

Option 4:

Paramagnetic and ferromagnetic materials

Correct Answer:

diamagnetic material only

Solution:

As we learnt in

Current loop as a magnetic dipole -

A current carrying circular coil behaves as a bar magnet whose magnetic moment is M

- wherein



magnetic susceptibility is negative for diamagnetic material only

Q. 35 A square loop ABCD carrying a current i , is placed near and coplanar with a long straight conductor XY carrying a current I , the net force on the loop will be:

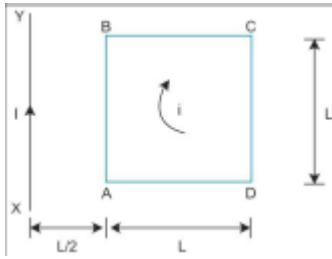

Option 1:

$$\frac{2\mu_0 i I}{3\pi}$$

Option 2:

$$\frac{\mu_0 i I}{2\pi}$$

Option 3:

$$\frac{2\mu_0 i I L}{3\pi}$$

Option 4:

$$\frac{\mu_0 i I L}{2\pi}$$

Correct Answer:

$$\frac{2\mu_0 i I}{3\pi}$$

Solution:

As we learnt in

Force between two parallel current carrying conductors -

$$F = \frac{\mu}{4\pi} \frac{2I_1 I_2 l}{a}$$

$$\frac{F}{l} = \frac{\mu_0}{4\pi} \frac{2I_1 I_2}{a}$$

- wherein

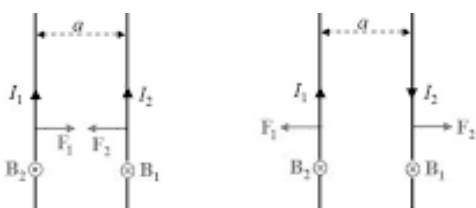

I_1 and I_2 current carrying two parallel wires

a-separation between two wires

force on arm AB due to current in conductor XY is $F_1 = \frac{\mu_0 2IiL}{4\pi \frac{L}{2}} = \frac{\mu_0 Ii}{\pi}$ (towards)

force on arm CD $F_2 = \frac{\mu_0 2IiL}{4\pi 3 \left(\frac{L}{2}\right)} = \frac{\mu_0 Ii}{3\pi}$ (away)

Net force on the loop

$$f_1 - f_2 = \frac{\mu_0 Ii}{\pi} \left[1 - \frac{1}{3} \right]$$
$$= \frac{2\mu_0 Ii}{3\pi}$$

- Q. 36** A uniform rope of length L and mass m_1 hangs vertically from a rigid support. A block of mass m_2 is attached to the free end of the rope. A transverse pulse of wavelength λ_1 is produced at the lower end of the rope. The wavelength of the pulse when it reaches the top of the rope is λ_2 . The ratio λ_2/λ_1 is:

Option 1:

$$\sqrt{\frac{m_1}{m_2}}$$

Option 2:

$$\sqrt{\frac{m_1 + m_2}{m_2}}$$

Option 3:

$$\sqrt{\frac{m_2}{m_1}}$$

Option 4:

$$\sqrt{\frac{m_1 + m_2}{m_1}}$$

Correct Answer:

$$\sqrt{\frac{m_1 + m_2}{m_2}}$$

Solution:

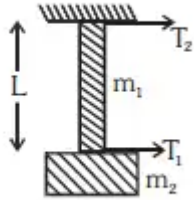

$$T_1 = m_2 g$$

$$T_2 = (m_1 + m_2) g$$

$$V \propto \sqrt{T}$$

$$\lambda \propto \sqrt{T}$$

$$\therefore \frac{\lambda_1}{\lambda_2} = \frac{\sqrt{T_1}}{\sqrt{T_2}}$$

$$\Rightarrow \frac{\lambda_1}{\lambda_2} = \frac{\sqrt{m_1 + m_2}}{\sqrt{m_2}}$$

Q. 37 When an α -particle of mass ' m ' moving with velocity ' v ' bombards on a heavy nucleus of charge ' Ze ', its distance of closet approach from the nucleus depends on m as:

Option 1:

$$\frac{1}{m}$$

Option 2:

$$\frac{1}{\sqrt{m}}$$

Option 3:

$$\frac{1}{m^2}$$

Option 4:

$$m$$

Correct Answer:

$$\frac{1}{m}$$

Solution:

When α particle is at the distance of the closest approach its velocity =0.

Hence kinetic energy =0.

Initial since α particles are at a far distance potential energy =0.

$$\therefore \text{Initial energy} = \frac{1}{2}mv^2$$

$$\text{Final energy} = \frac{1}{4\pi\epsilon_0} \cdot \frac{(ze) \cdot (2e)}{r_0}$$

r_0 is the distance of the current of the closest approach.

\Rightarrow From the principle of energy conservation initial energy = Final Energy

$$\Rightarrow \frac{1}{2}mv^2 = \frac{1}{4\pi\epsilon_0} \cdot \frac{2ze^2}{r_0}$$

$$\therefore r_0 = \frac{4ze^2}{4\pi\epsilon_0mv^2}$$

$$\therefore r_0 \propto \frac{1}{m}$$

Hence, the answer is the option (1).

Q. 38 A disk and a sphere of the same radius but different masses roll off on two inclined planes of the same altitude and lengths. Which one of the two objects gets to the bottom of the plane first?

Option 1:

Disk

Option 2:

Sphere

Option 3:

Both reach at the same time

Option 4:

Depends on their masses

Correct Answer:

Sphere

Solution:

Rolling of a body on an inclined plane -

$$a = \frac{g \sin \Theta}{1 + \frac{K^2}{R^2}}$$

$$f = \frac{mg \sin \Theta}{1 + \frac{R^2}{K^2}}$$

$$V \propto \frac{1}{\sqrt{1 + \frac{K^2}{R^2}}}, a \propto \frac{1}{1 + \frac{K^2}{R^2}}$$

$$t \propto \sqrt{1 + \frac{K^2}{R^2}}$$

If the value of $\frac{K^2}{R^2}$ is less, the moment of inertia will be less and greater will be its velocity. The solid body will reach the bottom first.

Hence, the answer is the option (2).

Q. 39 From a disc of radius R and mass M, a circular hole of diameter R, whose rim passes through the centre is cut. What is the moment of inertia of the remaining part of the disc, about a perpendicular axis, passing through the centre?

Option 1:
 $15MR^2/32$

Option 2:
 $13MR^2/32$

Option 3:
 $11MR^2/32$

Option 4:
 $9MR^2/32$

Correct Answer:
 $13MR^2/32$

Solution:

As we learnt in

Moment of inertia for disc -

$$I = \frac{1}{2}MR^2$$

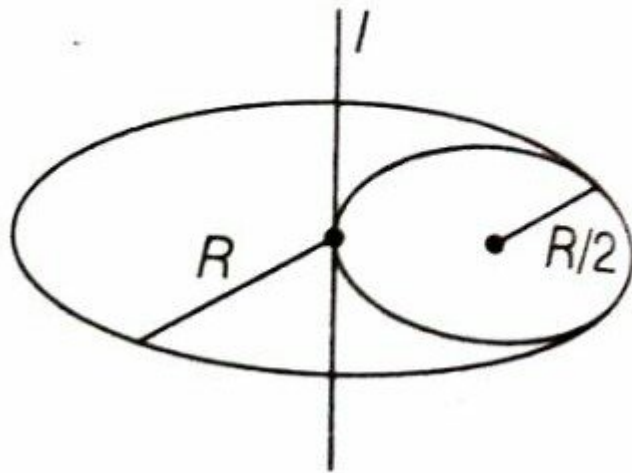

$$= \frac{MR^2}{2} - \left[\frac{3}{32}MR^2 \right]$$

$$I_{\text{remain}} = \frac{13}{32}MR^2$$

- wherein

About an axis perpendicular to the plane of disc & passing through its centre .

$$I = I_{\text{remain}} + I_{\frac{R}{2}}$$

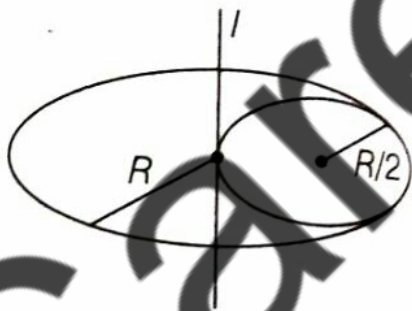

$$I_{\text{remain}} = I - I_{\frac{R}{2}}$$

$$= \frac{MR^2}{2} - \left[\frac{M}{4} \left(\frac{R}{2} \right)^2 + \frac{M}{4} \left(\frac{R}{2} \right)^2 \right]$$

$$= \frac{MR^2}{2} - \left[\frac{MR^2}{32} + \frac{MR^2}{16} \right]$$

$$= \frac{MR^2}{2} - \frac{3MR^2}{32}$$

$$I_{\text{remaining}} = \frac{13MR^2}{32}$$

Q. 40 A long solenoid has 1000 turns. When a current of 4A flows through it, the magnetic flux linked with each turn of the solenoid is 4×10^{-3} Wb. The self-inductance of the solenoid is:

Option 1:

4 H

Option 2:

3 H

Option 3:

2 H

Option 4:

1 H

Correct Answer:

1 H

Solution:

Coefficient of self-induction -

$$\phi \propto I \Rightarrow N\phi \propto I$$

$$N\phi = LI$$

$$L = \frac{N\phi}{I}$$

wherein

$N\phi$ = The number of flux linkage with a coil.

$$N = 1000, \quad I = 4A, \quad \phi_o = 4 \times 10^{-3}wb$$

Total flux linked with the solenoid, $\phi = N\phi_o$

$$\phi = 1000 \times 4 \times 10^{-3}wb = 4wb$$

$$\phi = LI \Rightarrow L = \frac{\phi}{I} = \frac{4wb}{4A} = 1H$$

Hence, the answer is the option (4).

Q. 41 What is the minimum velocity with which a body of mass m must enter a vertical loop of radius R so that it can complete the loop?

Option 1:

$$\sqrt{gR}$$

Option 2:

$$\sqrt{2gR}$$

Option 3:

$$\sqrt{3gR}$$

Option 4:

$$\sqrt{5gR}$$

Correct Answer:

$$\sqrt{5gR}$$

Solution:

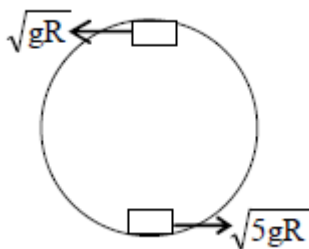

Q. 42 The molecules of a given mass of a gas have r.m.s. velocity of 200 ms^{-1} at 27°C and $1.0 \times 10^5 \text{ Nm}^{-2}$ pressure. When the temperature and pressure of the gas respectively, 127°C and $0.05 \times 10^5 \text{ Nm}^{-2}$, the r.m.s. velocity of its molecules in ms^{-1} is

Option 1:

$$100\sqrt{2}$$

Option 2:

$$\frac{400}{\sqrt{3}}$$

Option 3:

$$\frac{100\sqrt{2}}{3}$$

Option 4:

$$\frac{100}{3}$$

Correct Answer:

$$\frac{400}{\sqrt{3}}$$

Solution:

As we learnt in

Root mean square velocity -

$$V_{rms} = \sqrt{\frac{3RT}{M}}$$

$$= \sqrt{\frac{3P}{\rho}}$$

- wherein

R = Universal gas constant

M = molar mass

P = pressure due to gas

ρ = density

$$V_{rms} = 200 \text{ m/s}$$

at $T = 27^\circ\text{C} = 300\text{K}$

$$p = 10^5 \text{ Nm}^{-2}$$

$$V_{rms} = \sqrt{\frac{rRT}{M}}$$

V_{rms} is independent to pressure.

$$\therefore \frac{V_1}{V_2} = \sqrt{\frac{T_1}{T_2}} = \sqrt{\frac{300}{400}} \quad (T_2 = 127^\circ = 400\text{k})$$

$$\text{or } V_2 = V_1 \cdot \left(\frac{2}{\sqrt{3}}\right) = \frac{200 \times 2}{\sqrt{3}} = \frac{400}{\sqrt{3}} \text{ m/s}$$

-
- Q. 43** The charge flowing through a resistance R varies with time t as $Q = at - bt^2$, where a and b are positive constants. The total heat produced in R is:

Option 1:

$$\frac{a^3 R}{6b}$$

Option 2:

$$\frac{a^3 R}{3b}$$

Option 3:

$$\frac{a^3 R}{2b}$$

Option 4:

$$\frac{a^3 R}{b}$$

Correct Answer:

$$\frac{a^3 R}{6b}$$

Solution:

$$Q = at - bt^2 I = dQ/dt = a - 2bt$$

$$I = 0 \text{ for } t = t_0 = \frac{a}{2b} \text{ i.e, current flows from } t=0 \rightarrow t=t_0$$

$$\text{the heat produced is } \int_0^{t_0} i^2 R dt = \frac{a^3 R}{6b}$$

Hence, the answer is the option (1).

Q. 44 A refrigerator works between 4°C and 30°C. It is required to remove 600 calories of heat every second in order to keep the temperature of the refrigerated space constant. The power required is:

(Take 1 cal = 4.2 joules)

Option 1:

2.365 W

Option 2:

23.65 W

Option 3:

236.5 W

Option 4:
2365 W

Correct Answer:
236.5 W

Solution:

As we learnt in

Coefficient of performance (beta) -

$$\beta = \frac{Q_2}{Q_1 - Q_2} = \frac{T_2}{T_1 - T_2}$$

- wherein

$$T_1 > T_2$$

For a perfect refrigerator $\beta \rightarrow \infty$

$$Q_2 = 600 \text{ cal/sec}$$

$$= 600 \times 4.2 \text{ J/s} = 2520 \text{ W}$$

$$\beta = \frac{T_2}{T_1 - T_2} = \frac{Q_2}{W}$$

$$\text{or } \frac{277}{303 - 277} = \frac{2520}{W}$$

$$\text{or } W = \frac{2520 \times 26}{277} = 236.5 \text{ W}$$

Correct option is 3.

Q. 45 A uniform circular disc of radius 50 cm at rest is free to turn about an axis which is perpendicular to its plane and passes through its centre. It is subjected to a torque which produces a constant angular acceleration of 2.0 rad s^{-2} . Its net acceleration in ms^{-2} at the end of 2.0 s is approximately:

Option 1:
8.0

Option 2:
7.0

Option 3:
6.0

Option 4:

3.0

Correct Answer:

8.0

Solution:

$$\alpha = 2\text{rad/s}^2, w = \alpha t = 4\text{rad/s}^2$$

$$a_c = w^2 r = 4^2 \times 0.5 = 8\text{m/s}^2$$

$$a_t = \alpha r = 1\text{m/s}^2$$

$$\sqrt{a_c^2 + a_t^2} = \sqrt{8^2 + 1^2} = \sqrt{65}$$

$$a = 8\text{m/s}^2$$

Hence, the answer is the option (1).

Chemistry

- Q. 1** Which of the following statement about the composition of the vapour over an ideal 1:1 molar mixture of benzene and toluene is correct? Assume that the temperature is constant at 25°C. (**Given:** Vapour Pressur Data at 25°C, benzene = 12.8 kPa, toluene = 3.85 kPa)

Option 1:

The vapour will contain a higher percentage of benzene

Option 2:

The vapour will contain a higher percentage of toluene

Option 3:

The vapour will contain equal amounts of benzene and toluene

Option 4:

Not enough information is given to make a prediction

Correct Answer:

The vapour will contain a higher percentage of benzene

Solution:

Roult's Law - The total vapour pressure of the binary mixture of miscible liquids ideally is given by

$$P_T = P_A^0 x_A + P_B^0 x_B$$

Now,

Vapour pressure due to benzene = $P_A x_A$

x_A = mole fraction of benzene in solution

P_A = vapour pressure of benzene = 12.8 kPa

And,

Vapour pressure due to toluene = $P_B x_B$

x_B = mole fraction of toluene

P_B = vapour pressure of toluene = 3.85 kPa

Since, $x_A = x_B$

$\therefore P_A x_A > P_B x_B$

as $P_A > P_B$

Therefore, vapour will contain more benzene due to its higher pressure.

Hence, the answer is the option (1).

Q. 2 Match the compounds given in column I with the hybridisation and shape given in column II and mark the correct option.

Column-I	Column-II
1. XeF_6	(i) Distorted octahedral
2. XeO_3	(ii) Square planar
3. $XeOF_4$	(iii) Pyramidal
4. XeF_4	(iv) Square pyramidal

Option 1:

Code:

1 2 3 4
(i) (iii) (iv) (ii)

Option 2:

Code:

1 2 3 4
(i) (ii) (iv) (iii)

Option 3:

Code:

1 2 3 4
(iv) (iii) (i) (ii)

Option 4:

Code:

- 1 2 3 4
(iv) (i) (ii) (iii)

Correct Answer:

Code:

- 1 2 3 4
(i) (iii) (iv) (ii)

Solution:

	Compound	Structure	Hybridization
1.	XeF_6	Distorted octahedral	sp^3d^3
2.	XeO_3	Pyramidal	sp^3
3.	$XeOF_4$	square pyramidal	sp^3d^2
4.	XeF_4	Square planar	sp^3d^2

$$S.N = \frac{V + M - Q}{2}$$

S.N is the steric number and tells hybridization.

V is the number of valence electrons in the central atom.

M is the number of surrounding atoms except O.

Q is the charge present on an ion.

The correct answer is option 1.

Q. 3 The correct statement regarding the comparison of staggered and eclipsed conformations of ethane is:

Option 1:

The staggered conformation of ethane is less stable than eclipsed conformation, because staggered conformation has torsional strain

Option 2:

The eclipsed conformation of ethane is more stable than staggered conformation, because eclipsed conformation has no torsional strain

Option 3:

The eclipsed conformation of ethane is more stable than staggered conformation even though the eclipsed conformation has torsional strain

Option 4:

The staggered conformation of ethane is more stable than eclipsed conformation, because staggered conformation has no torsional strain.

Correct Answer:

The staggered conformation of ethane is more stable than eclipsed conformation, because staggered conformation has no torsional strain.

Solution:

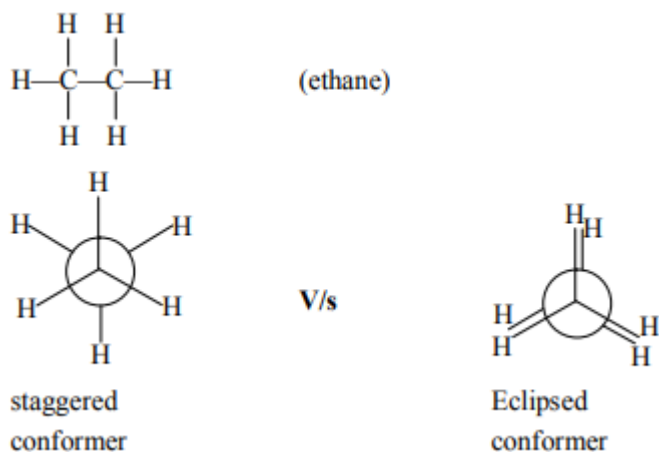

Thus, staggered conformation is more stable than eclipsed conformation because of no torsional strain.

Q. 4 Fog is a colloidal solution of

Option 1:

Liquid in gas

Option 2:

Gas in liquid

Option 3:

Solid in gas

Option 4:

Gas in gas

Correct Answer:

Liquid in gas

Solution:

Fog appears when water vapors condense to form tiny droplets which are suspended in the air. The droplets fall in the size category of a colloid.

Fog is an example of aerosol in which the dispersed phase is liquid and the dispersion medium is gas

Hence, option 1 is correct.

Q. 5 Match items of Column I with the items of Column II and assign the correct code:

Column-I	Column-II
(A) Cyanide process	(i) Ultrapure Ge
(B) Froth floatation process	(ii) Dressing of ZnS
(C) Electrolytic reduction	(iii) Extraction of Al
(D) Zone refining	(iv) Extraction of Au
	(v) Purification of Ni

Option 1:

Code:

(1) (2) (3) (4)
(iv) (ii) (iii) (i)

Option 2:

Code:

(1) (2) (3) (4)
(ii) (iii) (i) (v)

Option 3:

Code:

(1) (2) (3) (4)
(i) (ii) (iii) (iv)

Option 4:

Code:

(1) (2) (3) (4)
(iii) (iv) (v) (i)

Correct Answer:

Code:

(1) (2) (3) (4)
(iv) (ii) (iii) (i)

Solution:

The cyanide process is used for the extraction of Au and Ag.

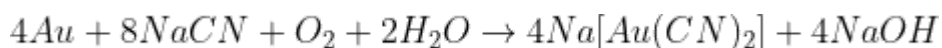

Froth floatation process is used for dressing ZnS. This process is used for dressing sulfide ores.

Electrolytic reduction is used in the extraction of Al and highly electropositive elements like K, Na, Al, etc which can not be reduced in an aqueous medium.

Zone refining is used to get metals of ultra-high purity such as Ge, Si, B, Ga, and other metalloids. It's based on the solubility of the impurities in the melt more than the solid.

Therefore, **Option(1) is correct.**

Q. 6 Which is the correct statement for the given acids?

Option 1:

Phosphinic acid is a diprotic acid while phosphonic acid is a monoprotic acid

Option 2:

Phosphinic acid is a monoprotic acid while phosphonic acid is a diprotic acid

Option 3:

Both are triprotic acids

Option 4:

Both are diprotic acids

Correct Answer:

Phosphinic acid is a monoprotic acid while phosphonic acid is a diprotic acid

Solution:

As we learnt in

Hypophosphorus Acid -

H_3PO_2 (+1), monobasic

- wherein

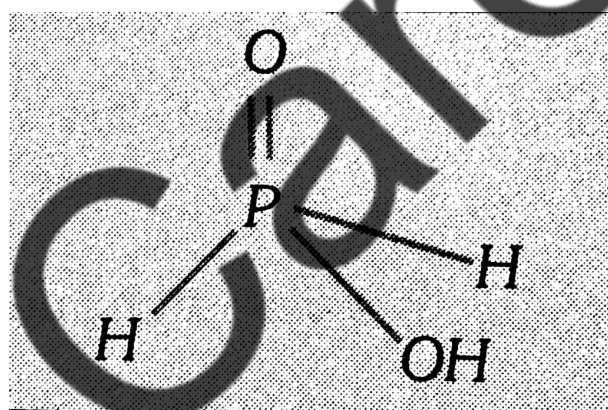

and

Phosphorus Acid -

H_3PO_3 (+3), dibasic

- wherein

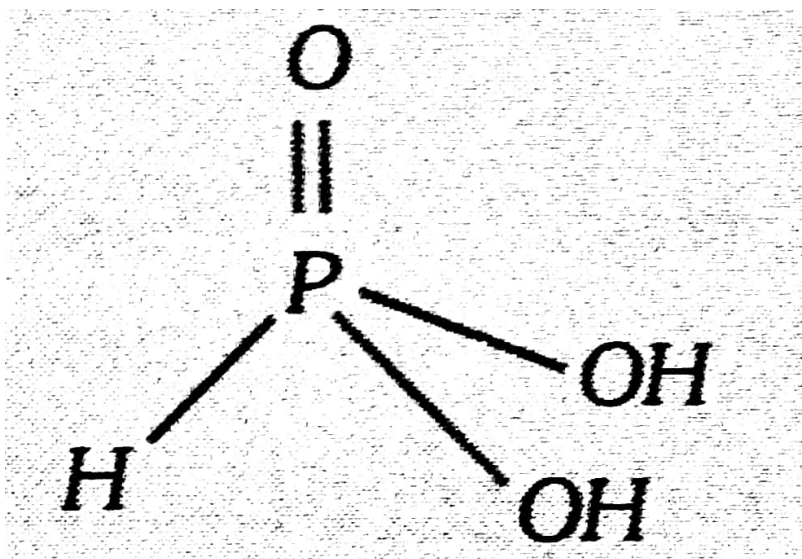

Phosphoric acid or hyperphosphorus acid

H_3PO_2 has the structure

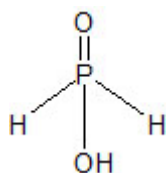

Clearly, with one hydroxide group, it is monoprotic.

Phosphilic acid or hypophosphorus acid H_3PO_3 has the structure

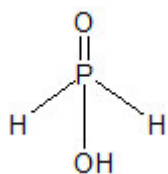

With 2 hydroxide groups, it is monoprotic.

Phosphoric acid or Phosphorus acid

H_3PO_3

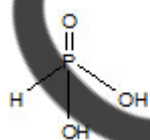

With 2 hydroxide groups, it is difratic..

Q. 7 The correct thermodynamic conditions for the spontaneous reaction at all temperatures is:

Option 1:

$\Delta H > 0$ and $\Delta S > 0$

Option 2:

$\Delta H > 0$ and $\Delta S < 0$

Option 3:

$\Delta H < 0$ and $\Delta S > 0$

Option 4:

$\Delta H < 0$ and $\Delta S < 0$

Correct Answer:

$\Delta H < 0$ and $\Delta S > 0$

Solution:

$$\Delta G = \Delta H - T\Delta S$$

For spontaneous $\Delta G < 0$

Or, $\Delta H - T\Delta S < 0$

If $\Delta H < 0$ and $\Delta S > 0$

For this reaction to be spontaneous, ΔG must be negative. This should be negative and should be positive.

Hence, the answer is the option (3).

Q. 8 Which one of the following statements is correct when SO_2 is passed through acidified $K_2Cr_2O_7$ solution?

Option 1:

The solution turns blue

Option 2:

The solution is decolourized

Option 3:

SO_2 is reduced

Option 4:

Green $Cr_2(SO_4)_3$ is formed

Correct Answer:

Green $Cr_2(SO_4)_3$ is formed

Solution:

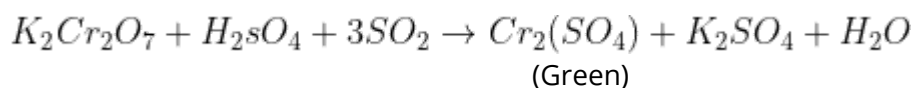

Hence, the answer is the option (4).

Q. 9 The correct statement regarding RNA and DNA, respectively is :

Option 1:

The sugar component in RNA is arabinose and the sugar component in DNA is 2'- deoxyribose.

Option 2:

The sugar component in RNA is ribose and the sugar component in DNA is 2'- deoxyribose.

Option 3:

The sugar component in RNA is arabinose and the sugar component in DNA is ribose.

Option 4:

The sugar component in RNA is 2'- deoxyribose and the sugar component in DNA is arabinose.

Correct Answer:

The sugar component in RNA is ribose and the sugar component in DNA is 2'- deoxyribose.

Solution:

Ribonucleic acid (RNA) -

Made up of nucleotides consisting of pentose sugar which is $\beta - D$ -ribose, Phosphoric acid and bases (Adenine, Guanine, cytosine and uracil)

Deoxyribonucleic acid (DNA) -

Made up of nucleotides consisting of pentose sugar which is $\beta - D - 2$ - deoxyribose, Phosphoric acid and bases (Adenine, Guanine, cytosine and thymine)

The sugar component in RNA ribose and the sugar component in DNA is 2'- deoxyribose.

Hence, the answer is the option (2).

Q. 10 Which of the following reagents would distinguish cis - cyclopentane-1,2-diol from the trans-isomer?

Option 1:

Acetone

Option 2:

Ozone

Option 3:

MnO₂

Option 4:

Aluminium isopropoxide

Correct Answer:

Acetone

Solution:

cis-cyclopentane-1, 2-diol when reacts with acetone, forms cyclic ketal whereas trans-isomer of cyclopentane-1,2-diol can not form cyclic ketal.

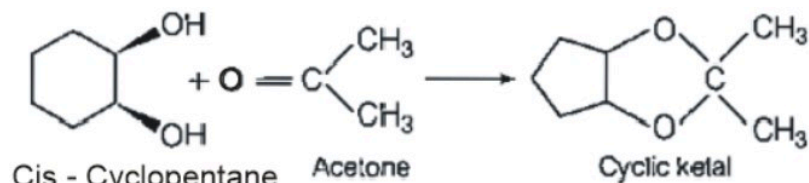

But,

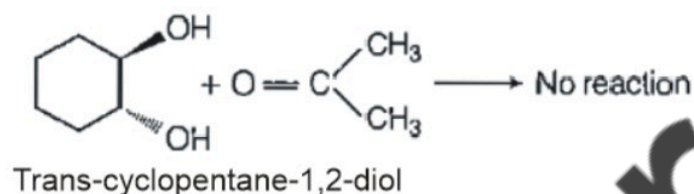

Q. 11 The correct statement regarding a carbonyl compound with a hydrogen atom on its alpha-carbon, is:

Option 1:

A carbonyl compound with a hydrogen atom on its alpha-carbon never equilibrates with its corresponding enol

Option 2:

A carbonyl compound with a hydrogen atom on its alpha-carbon rapidly equilibrates with its corresponding enol and this process is known as aldehyde-ketone equilibration.

Option 3:

A carbonyl compound with a hydrogen atom on its alpha-carbon rapidly equilibrates with its corresponding enol and this process is known as carbonylation.

Option 4:

A carbonyl compound with a hydrogen atom on its alpha-carbon rapidly equilibrates with its corresponding enol and this process is known as keto-enol tautomerism.

Correct Answer:

A carbonyl compound with a hydrogen atom on its alpha-carbon rapidly equilibrates with its corresponding enol and this process is known as keto-enol tautomerism.

Q. 12 At 100°C the vapour pressure of a solution of 6.5g of a solute in 100g water is 732 mm. If $K_b=0.52$, the boiling point of this solution will be:

Option 1:

101°C

Option 2:

100°C

Option 3:

102°C

Option 4:

103°C

Correct Answer:

101°C

Solution:

$$\frac{P_A^\circ - P_A}{P_A} = \frac{m \times M_A}{1000}$$

$$\frac{760 - 732}{732} = \frac{m \times 18}{1000}$$

$$m = 2.125$$

$$\Delta T_b = K_b m$$

$$= 0.52 \times 2.125$$

$$= 1.10$$

$$T_s = 100 + 1.10$$

$$= 101.1^\circ\text{C}$$

Hence, the answer is the option (1).

Q. 13 Consider the nitration of benzene using mixed conc of H_2SO_4 and HNO_3 . If a large amount of $KHSO_4$ is added to the mixture, the rate of nitration will be

Option 1:

faster

Option 2:

slower

Option 3:

unchanged

Option 4:
doubled

Correct Answer:
slower

Solution:

Effect of concentration change on the equilibrium - When the concentration of any of the reactants or products in a reaction at equilibrium is changed, the equilibrium mixture's composition changes to minimize the effect of concentration change. If we add reactant, the equilibrium shifts towards the right. In the nitration of benzene in the presence of concentrated, benzene is formed.

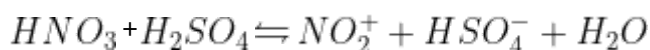

If a large amount of added to this mixture more HSO_4^- ion furnishes and hence the concentration of electrophile decreases, rate of electrophile aromatic reaction slows down.

Hence, the answer is the option (2).

Q. 14 The pressure of H_2 required to make the potential of H_2 - electrode zero in pure water at 298 K is:

Option 1:
 10^{-14} atm

Option 2:
 10^{-12} atm

Option 3:
 10^{-10} atm

Option 4:
 10^{-4} atm

Correct Answer:
 10^{-14} atm

Solution:

We know that for pure water $pH = 7$

$$-\log[H^+] = 7 \quad \text{or} \quad [H^+] = 10^{-7}$$

The reaction will be

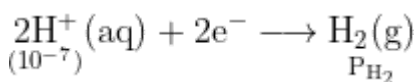

Electrode Potential (Nernst Equation) of the above reaction.

$$E_{\text{electrode}} = E_{\text{H}^+/\text{H}_2}^\circ - \frac{0.0591}{2} \log \frac{P_{\text{H}_2}}{[\text{H}^+]^2}$$

Need to make electrode potential Zero.

$$\text{So, } E_{\text{electrode}} = 0 \text{ V}$$

$$\text{And we know that } E_{\text{H}^+/\text{H}_2}^\circ = 0 \text{ V}$$

Hence,

$$0 = 0 - \frac{0.0591}{2} \log \frac{P_{\text{H}_2}}{(10^{-7})^2}$$

$$P_{\text{H}_2} = 10^{-14} \text{ atm}$$

Hence, the answer is the option (1).

Q. 15 The correct statement regarding the basicity of arylamines is

Option 1:

Arylamines are generally less basic than alkylamines because the nitrogen lone-pair electrons are delocalized by interaction with the aromatic ring π electron system.

Option 2:

Arylamines are generally more basic than alkylamines because the nitrogen lone-pair electrons are not delocalized by interaction with the aromatic ring π electron system.

Option 3:

Arylamines are generally more basic than alkylamines because of aryl group.

Option 4:

Arylamines are generally more basic than alkylamines, because the nitrogen atom in arylamines is sp-hybridized.

Correct Answer:

Arylamines are generally less basic than alkylamines because the nitrogen lone-pair electrons are delocalized by interaction with the aromatic ring π electron system.

Solution:

Basicity of Aromatic Amines - The unshared pair of electrons at the nitrogen atom is in resonance with the benzene ring and hence not fully available for donation as in the case of aniline.

The general order of basicity - Aliphatic Amines > Ammonia > Aromatic Amines

Hence, the answer is the option (1).

Q. 16 In a protein molecule, various amino acids are linked together by:

Option 1:

α -glycosidic bond

Option 2:

β -glycosidic bond

Option 3:

Peptide bond

Option 4:

Dative bond

Correct Answer:

Peptide bond

Solution:

Peptide bonds -

The bond between two amino acid

- wherein

formed by condensation reaction

In protein molecules, various amino acids are linked together by a peptide bond

Hence, the answer is the option (3).

Q. 17 Consider the molecules CH_4 , NH_3 and H_2O . Which of the given statements is false?

Option 1:

The H - C - H bond angle in CH_4 , the H - N - H bond angle in NH_3 , and the H - O - H bond angle in H_2O are all greater than 90° .

Option 2:

The H - O - H bond angle in H_2O is larger than the H - C - H bond angle in CH_4 .

Option 3:

The H - O - H bond angle in H_2O is smaller than the H - N - H bond angle in NH_3 .

Option 4:

The H - C - H bond angle in CH_4 is larger than the H - N - H bond angle in NH_3 .

Correct Answer:

The H - O - H bond angle in H_2O is larger than the H - C - H bond angle in CH_4 .

Solution:

VSEPR Theory -

1. The shape of the molecule is determined by repulsions between all of the electron pair present in valence shell.

2. Order of repulsion

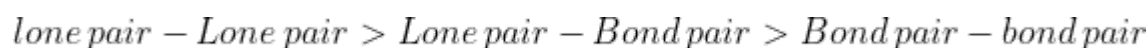

3 Repulsion among the bond pair is directly proportional to the bond order and electronegativity difference between the central atom and the other atom.

-

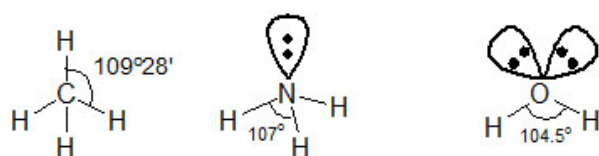

From the above figure it is clear that H—O—H bond angle in H_2O is smaller than H—C—H bond angles in CH_4 .

Therefore, **Option(2) is correct.**

Q. 18 Which of the following statements is false?

Option 1:

Mg^{2+} ions form a complex with ATP

Option 2:

Ca^{2+} ions are important in blood clotting

Option 3:

Ca^{2+} ions are not important in maintaining the regular beating of the heart.

Option 4:

Mg^{2+} ions are important in the green parts of plants.

Correct Answer:

Ca^{2+} ions are not important in maintaining the regular beating of the heart.

Solution:

Biological Significance of Calcium -

1. Required for the formation of the teeth and bones.
2. Essential for neuromuscular function, interneuronal transmission, and cell membrane integrity.
3. Required for blood coagulation.
4. Acts as a secondary messenger in cell signaling.

Ca^{2+} is involved in the generation and transmission of current to the heart muscles and is, therefore, necessary for maintaining a regular heartbeat.

Hence, the correct option is option 3.

Q. 19 Which one of the following orders is correct for the bond dissociation enthalpy of halogen molecules?

Option 1:



Option 2:

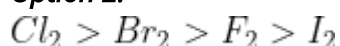

Option 3:



Option 4:



Correct Answer:

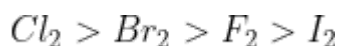

Solution:

Bond dissociation energies of the halogen family decrease down the group as the size of the atom increases. The bond dissociation energy of fluorine, is, however, lower than those of chlorine and bromine because of interelectronic repulsions present in the small atom of fluorine. Thus, bond energy decreases in the order

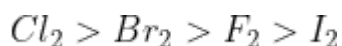

Hence, the answer is the option (2).

Q. 20 The rate of a first-order reaction is $0.04 \text{ mol L}^{-1}\text{s}^{-1}$ at 10 seconds and $0.03 \text{ mol L}^{-1}\text{s}^{-1}$ at 20 seconds after initiation of the reaction. The half-life period of the reaction is :

Option 1:

24.1 s

Option 2:

34.1 s

Option 3:

44.1 s

Option 4:

54.1 s

Correct Answer:

24.1 s

Solution:

For a first-order reaction $A \rightarrow \text{product}$ and for the concentration of the reactant at two different times.

$$K = \frac{2.303}{t_2 - t_1} \log \frac{[A]_1}{[A]_2}$$

$$\Rightarrow K = \frac{2.303}{t_2 - t_1} \log \frac{(\text{rate})_1}{(\text{rate})_2} \quad [\because \text{rate} \propto [A]]$$

$$K = \frac{2.303}{(20 - 10)} \log \frac{(0.04)}{(0.03)}$$

$$K = 0.0287 \text{ sec}^{-1}$$

We know, the half-life of first-order reaction -

$$t_{\frac{1}{2}} = \frac{0.693}{K}$$

$$t_{\frac{1}{2}} = \frac{0.693}{0.0287} = 24.1 \text{ sec}$$

Hence, the answer is the option (1).

Q. 21 Which one given below is a non-reducing sugar?

Option 1:

Maltose

Option 2:

Lactose

Option 3:

Glucose

Option 4:

Sucrose

Correct Answer:

Sucrose

Solution:

Reducing Sugar -

They contain free aldehyde ($-CHO$) or Ketone ($-C = O$) group and are capable of reducing Fehling solution and Tollen's reagent.

- wherein

Eg. Maltose, Glucose, Fructose, Xylose

Those carbohydrates which reduce Tollen's and Fehling's solution are called reducing sugar. Sucrose doesn't reduce Tollen's reagent.

Hence, the answer is the option (4).

Q. 22 Which one of the following characteristics is associated with adsorption?

Option 1:

ΔG is negative but ΔH and ΔS are positive.

Option 2:

ΔG , ΔH and ΔS all are negative.

Option 3:

ΔG and ΔH are negative but ΔS is positive.

Option 4:

ΔG and ΔS are negative but ΔH is positive.

Correct Answer:

ΔG , ΔH and ΔS all are negative.

Solution:

For a process to be spontaneous the value of ΔG must be negative. Since adsorption is a spontaneous process the $\Delta G = -ve$.

Now,

$$\Delta G = \Delta H - T\Delta S$$

Adsorption is an exothermic process because of the presence of weak Vander Waal forces of attraction between adsorbate and adsorbent hence $\Delta H = -ve$.

Now there is a decrease in entropy during the adsorption process because gases get adsorbed on the surface of solid and the movement of gas particles is restricted hence, $\Delta S = -ve$.

The correct answer is option 2.

Q. 23 Two electrons occupying the same orbital are distinguished by :

Option 1:

Principle quantum number

Option 2:

Magnetic quantum number

Option 3:

Azimuthal quantum number

Option 4:

Spin quantum number

Correct Answer:

Spin quantum number

Solution:

As we learned in

Spin Quantum Number (m_s) -

It has two values $+1/2$ and $-1/2$

For the two electrons occupying the same orbital value of n , l and m are the same but m_s is different.

$$m_s = +\frac{1}{2} \text{ and } m_s = -\frac{1}{2}$$

Hence, the answer is the option (4).

Q. 24 Lithium has a bcc structure. Its density is 530 kg m^{-3} and its atomic mass is 6.94 g mol^{-1} . Calculate the edge length of a unit cell of Lithium metal. ($N_A = 6.02 \times 10^{23} \text{ mol}^{-1}$)

Option 1:

154 pm

Option 2:

352 pm

Option 3:

527 pm

Option 4:

264 pm

Correct Answer:

352 pm

Solution:

As we learned in

The density of cubic unit cell -

$$d = \frac{zM}{a^3 N_A}$$

Where,

d = density of crystal

z = no. of effective constituent particles in one unit cell

M = molecular weight

a = edge length of the unit cell

$$N_A = 6.022 \times 10^{23}$$

So,

$$a = \left(\frac{zM}{dN_A} \right)^{\frac{1}{3}}$$

$$a = \left(\frac{2 \times 6.94}{0.530 \text{g} \times 6.02 \times 10^{23}} \right)^{\frac{1}{3}}$$

$$a = 3.52 \times 10^{-10} \text{ m}$$

$$a = 352 \text{ pm}$$

Therefore, the correct option is (2).

Q. 25 The pair of electron in the given carbanion, $\text{CH}_3\text{C} \equiv \text{C}^-$, is present in which of the following orbitals?

Option 1:

2p

Option 2:

sp^3

Option 3:

sp^2

Option 4:

sp

Correct Answer:

sp

Solution:

Carbanion -

Those chemical species in which carbon-bearing negative charge is called carbanion

- wherein



$$\text{Hybridisation} = \frac{\text{Number of } \sigma^- \text{ electron}}{2} = \frac{2+2}{2} = 2 = sp$$

i.e. pair of electrons is present in sp -hybridised orbital.

Hence, the answer is the option (4).

Q. 26 The product obtained as a result of a reaction of nitrogen with CaC_2 is

Option 1:

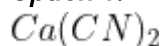

Option 2:

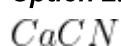

Option 3:

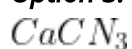

Option 4:

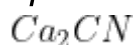

Correct Answer:

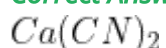
**Solution:**

As we learnt in

Manufacture of ammonia by Calcium Cyanamide -

$CaCN_2$ is hydrolysed with super heated steam

- wherein

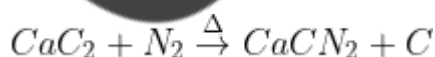

Calcium Cyanamide or nitrolin is obtained when CaC_2 reacts with nitrogen under high temperature.

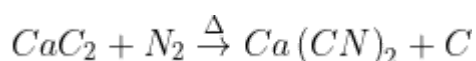

This reaction is also used manufacturing of ammonia through Cyanamide .

Q. 27 In the reaction,

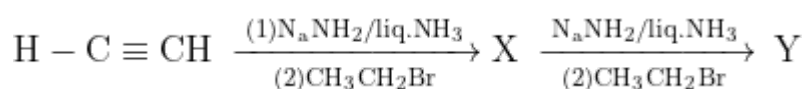

X and Y are:

Option 1:

X = 1-Butyne; Y = 3-Hexyne

Option 2:

X = 2-Butyne; Y = 3-Hexyne

Option 3:

X = 2-Butyne; Y = 2-Hexyne

Option 4:

X = 1-Butyne; Y = 2-Hexyne

Correct Answer:

X = 1-Butyne; Y = 3-Hexyne

Solution:

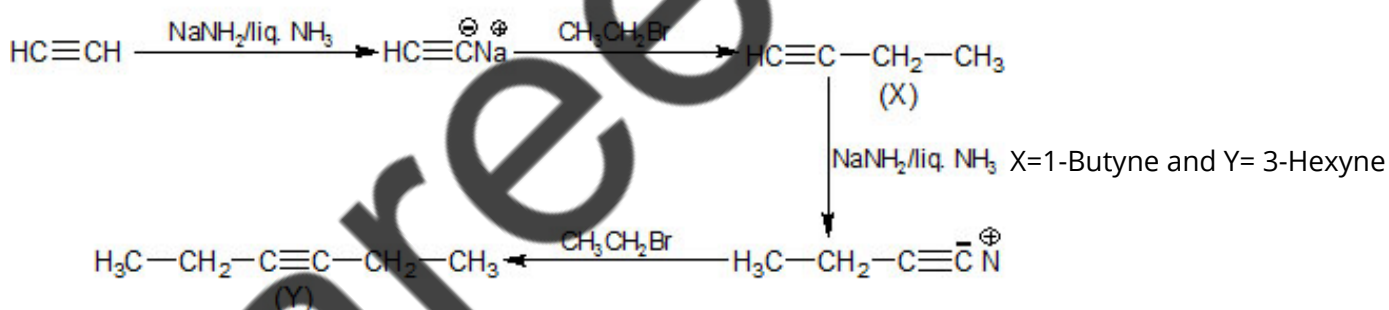

Therefore, **Option(1) is correct.**

Q. 28 MY and NY_3 , two nearly insoluble salts, have the same K_{sp} value of 6.2×10^{-13} at room temperature. Which statement would be true in regard to MY and NY_3 ?

Option 1:

The molar solubilities of MY and NY_3 in water are identical.

Option 2:

The molar solubility of MY in water is less than that of NY_3

Option 3:

The salts MY and NY_3 are more soluble in 0.5M KY than in pure water.

Option 4:

The addition of the salt of KY to solution of MY and NY_3 will have no effect on their solubilities

Correct Answer:

The molar solubility of MY in water is less than that of NY_3

Solution:

]The general expression of solubility product -

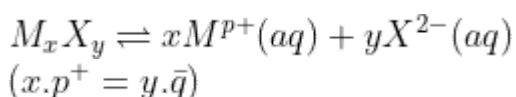

Its solubility product is

$$K_{sp} = [M^{p+}]^x [X^{2-}]^y$$

$$\text{For } MY \quad K_{sp} = S_1^2$$

$$\text{or } S_1 = \sqrt{K_{sp}} = \sqrt{6.2 \times 10^{-13}} = 7.87 \times 10^{-7} \text{ molL}^{-1}$$

$$\text{For } NY_3 \quad K_{sp} = 27S_2^4$$

$$\Rightarrow S_2 = \sqrt[4]{\frac{6.2 \times 10^{-13}}{27}} = 3.89 \times 10^{-4} \text{ molL}^{-1}$$

Hence, the answer is the option (2).

Q. 29 When copper is heated with conc. HNO_3 it produces

Option 1:

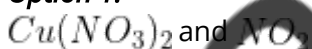

Option 2:

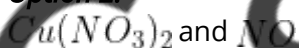

Option 3:



Option 4:

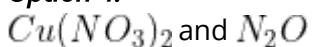

Correct Answer:

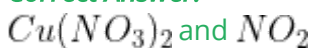

Solution:

The reaction is as follows:

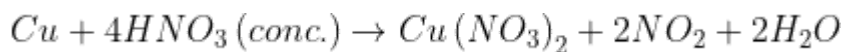

Here, HNO_3 acts as an oxidizing agent.

Hence, the answer is the option (1).

Q. 30 The product formed by the reaction of an aldehyde with a primary amine is

Option 1:
Schiff base

Option 2:
Ketone

Option 3:
Carboxylic acid

Option 4:
Aromatic acid

Correct Answer:
Schiff base

Solution:

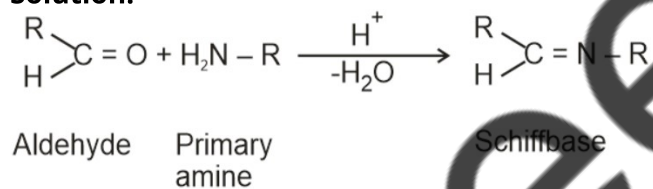

Q. 31 The addition of a catalyst during a chemical reaction alters which of the following quantities?

Option 1:
Entropy

Option 2:
Internal Energy

Option 3:
Enthalpy

Option 4:
Activation Energy

Correct Answer:
Activation Energy

Solution:

A catalyst is a surface that increases the rate of a chemical reaction without itself being used up. It remains unchanged chemically providing an alternate path for the reaction at an accelerated rate by lowering the activation energy.

The addition of a catalyst during a chemical reaction alters activation energy.

So, option 4 is correct.

Q. 32 Predict the correct order among the following:

Option 1:

lone pair - lone pair > lone pair - bond pair > bond pair - bond pair

Option 2:

lone pair - lone pair > bond pair - bond pair > lone pair - bond pair

Option 3:

bond pair - bond pair > lone pair - bond pair > lone pair - lone pair

Option 4:

lone pair - bond pair > bond pair - bond pair > lone pair - lone pair

Correct Answer:

lone pair - lone pair > lone pair - bond pair > bond pair - bond pair

Solution:

VSEPR Theory -

1. The shape of the molecule is determined by repulsions between all of the electron pairs present in the valence shell.

2. Order of repulsion

lone pair - Lone pair > Lone pair - Bond pair > Bond pair - bond pair

3 Repulsion among the bond pair is directly proportional to the bond order and electronegativity difference between the central atom and the other atom.

According to VSEPR theory, the repulsive forces between lone pair are greater than between lone pair and bond pair which are further greater than bond pair and bond pair.

Hence, the answer is the option (1).

Q. 33 Consider the following liquid-vapour equilibrium

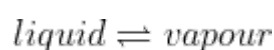

Which of the following relations are correct?

Option 1:

$$\frac{d \ln G}{dT^2} = \frac{\Delta H_v}{RT^2}$$

Option 2:

$$\frac{d \ln P}{dT} = \frac{\Delta H_v}{RT}$$

Option 3:

$$\frac{d \ln P}{dT^2} = \frac{-\Delta H_v}{T^2}$$

Option 4:

$$\frac{d \ln P}{dT} = \frac{-\Delta H_v}{RT^2}$$

Correct Answer:

$$\frac{d \ln P}{dT} = \frac{-\Delta H_v}{RT^2}$$

Solution:

$$\frac{d \ln P}{dT} = \frac{-\Delta H_v}{RT^2}$$

This equilibrium states that, when liquid is heated, it converts into vapour but on cooling, it further converts into liquid, which is derived by Clausius Flaperon and the relationship is written as,

$$\frac{d \ln P}{dT} = \frac{-\Delta H_v}{RT^2}$$

Hence, the answer is the option (4).

Q. 34 Which of the following biphenyls is optically active?

Option 1:

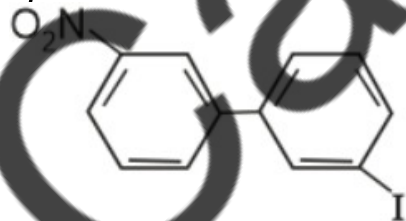

Option 2:

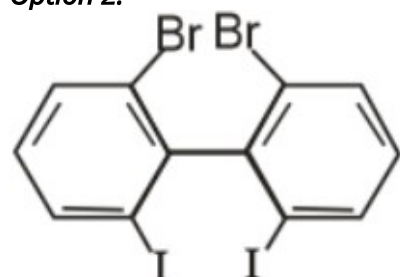

Option 3:

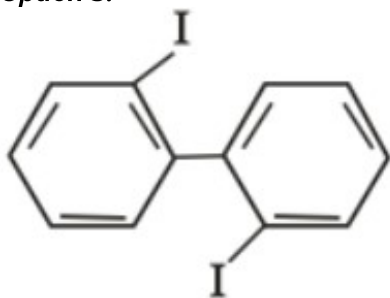

Option 4:

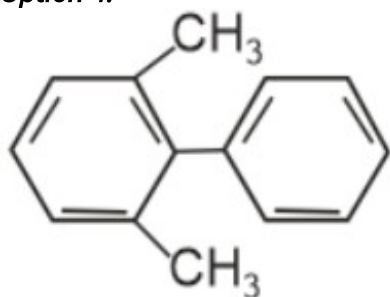

Correct Answer:

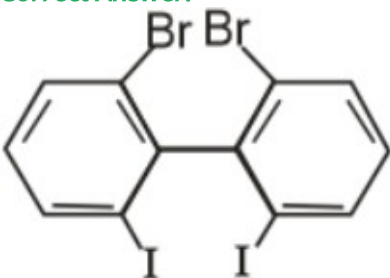

Solution:

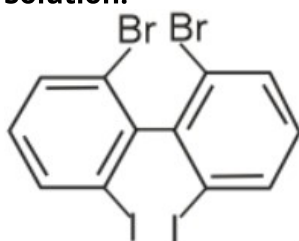

Compound do not have plane of symmetry (due to Non-Planar), so it is optically active.

→ Ortho substituted group (due to steric hindrance) makes the structure non-planar.

Q. 35 Which of the following statements about hydrogen is incorrect?

Option 1:

hydrogen has three isotopes of which tritium is the most common.

Option 2:

Hydrogen never acts as cation in ionic salts.

Option 3:

Hydronium ion, H_3O^+ exists freely in solution.

Option 4:

Dihydrogen acts as a reducing agent.

Correct Answer:

hydrogen has three isotopes of which tritium is the most common.

Solution:

As we learned in

Hydrogen has three isotopes. Protium, Deuterium and tritium.

Protium is the most common isotope of hydrogen with an abundance of 99.98%.

Therefore, the correct option is (1).

Q. 36 The electronic configurations of Eu (Atomic No. 63), Gd (Atomic No. 64) and Tb (Atomic No. 65) are.

Option 1:

$[\text{Xe}] 4f^7 6s^2$, $[\text{Xe}] 4f^8 6s^2$ and $[\text{Xe}] 4f^8 5d^1 6s^2$

Option 2:

$[\text{Xe}] 4f^6 5d^1 6s^2$, $[\text{Xe}] 4f^7 5d^1 6s^2$ and $[\text{Xe}] 4f^9 6s^2$

Option 3:

$[\text{Xe}] 4f^6 5d^1 6s^2$, $[\text{Xe}] 4f^7 5d^1 6s^2$ and $[\text{Xe}] 4f^8 5d^1 6s^2$

Option 4:

$[\text{Xe}] 4f^7 6s^2$, $[\text{Xe}] 4f^7 5d^1 6s^2$ and $[\text{Xe}] 4f^9 6s^2$

Correct Answer:

$[\text{Xe}] 4f^7 6s^2$, $[\text{Xe}] 4f^7 5d^1 6s^2$ and $[\text{Xe}] 4f^9 6s^2$

Solution:

Electronic configuration -

The lanthanoid follows the $4f^{1-14} 5d^{0-1} 6s^2$ configuration (the common configuration) with some exceptions due to fully filled half-filled electronic configuration.

Electronic config of $\text{Eu}_{63} = [\text{Xe}] 4f^7 6s^2$

Electronic config of $\text{Gd}_{64} = [\text{Xe}] 4f^7 5d^1 6s^2$

Electronic config of $\text{Tb}_{65} = [\text{Xe}] 4f^9 6s^2$

Hence, the answer is the option (4).

Q. 37 The reaction

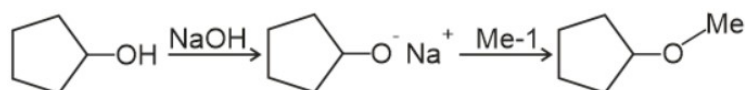

can be classified as:-

Option 1:

Williamson ether synthesis reaction

Option 2:

Alcohol formation reaction

Option 3:

Dehydration reaction

Option 4:

Williamson alcohol synthesis reaction

Correct Answer:

Williamson ether synthesis reaction

Solution:

Williamson's Synthesis -

- Nucleophilic substitution reaction involving $\text{S}_{\text{N}}2$ mechanism.
- Tertiary alkyl halide cannot be used because it undergoes elimination reaction forming alkenes.
- wherein

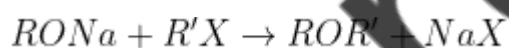

Q. 38 For the following reactions:

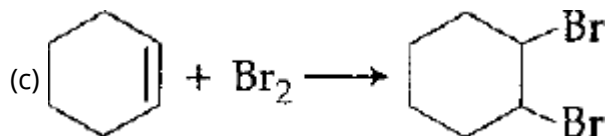
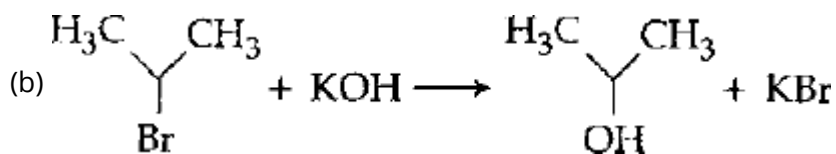
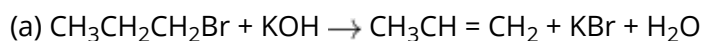

Which of the following statements is correct?

Option 1:

(a) and (b) are elimination reactions and (c) is addition reaction.

Option 2:

(a) is elimination, (b) is substitution and (c) is addition reaction.

Option 3:

(a) is elimination, (b) and (c) are substitution reactions.

Option 4:

(a) is substitution, (b) and (c) are addition reactions.

Correct Answer:

(a) is elimination, (b) is substitution and (c) is addition reaction.

Solution:

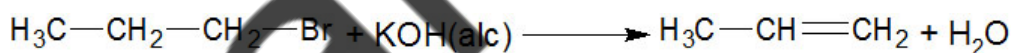

This reaction is elimination reaction.

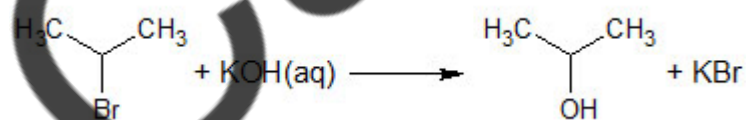

This reaction is nucleophilic substitution reaction.

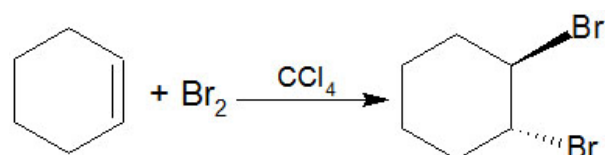

This reaction is an addition reaction.

Therefore, **Option(2) is correct.**

Q. 39 In which of the following options, the order of arrangement does not agree with the variation of property indicated against it?

Option 1:

$\text{Al}^{3+} < \text{Mg}^{2+} < \text{Na}^+ < \text{F}^-$ (increasing ionic size)

Option 2:

$\text{B} < \text{C} < \text{O} < \text{N}$ (increasing first ionisation enthalpy)

Option 3:

$\text{I} < \text{Br} < \text{Cl} < \text{F}$ (increasing electron gain enthalpy)

Option 4:

$\text{Li} < \text{Na} < \text{K} < \text{Rb}$ (increasing metallic radius)

Correct Answer:

$\text{I} < \text{Br} < \text{Cl} < \text{F}$ (increasing electron gain enthalpy)

Solution:

The correct order of increasing negative electron gain enthalpy is $\text{I} < \text{Br} < \text{F} < \text{Cl}$.

the correct order of increasing first ionization enthalpy is $\text{B} < \text{C} < \text{O} < \text{N}$.

Hence, the answer is the option (3).

Q. 40 Equal moles of hydrogen and oxygen gases are placed in a container with a pinhole through which both can escape. What fraction of the oxygen escapes in the time required for one-half of the hydrogen to escape?

Option 1:

1/8

Option 2:

1/4

Option 3:

3/8

Option 4:

1/2

Correct Answer:

1/8

Solution:

Graham's law of diffusion - The gas diffusion rate is inversely proportional to the square root of the molar mass of gas.

$$\frac{r_1}{r_2} = \sqrt{\frac{M_2}{M_1}}$$

where r is the rate of diffusion of gas, and M is molar mass.

Let the number of moles of each gas = x

Fraction of hydrogen escaped = $\frac{x}{2}$

$$\frac{r_{O_2}}{r_{H_2}} = \sqrt{\frac{M_{H_2}}{M_{O_2}}} = \frac{n_{O_2}/t}{n_{H_2}/t} = \sqrt{\frac{2}{32}} = \frac{1}{4}$$

$$\frac{n_{O_2}}{n_{H_2}} = \frac{1}{4}$$

$$n_{O_2} = \frac{n_{O_2}}{4} = \frac{x}{4 \times 2} = \frac{x}{8}$$

Hence fraction of oxygen escaped = $\frac{1}{8}$

The correct Option is 1.

Q. 41 Among the following, the correct order of acidity is:

Option 1:



Option 2:



Option 3:



Option 4:



Correct Answer:



Solution:

As we learnt in

Acidic strength of oxyacids -



Acidic strength \propto electronegativity of the central atom

The acidity of oxy acid \propto oxidation state of halogen

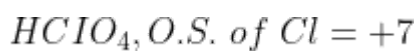
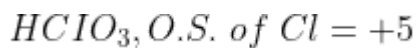
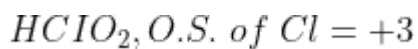
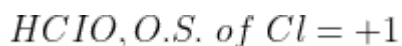

\therefore order of acidity: $\text{HClO}_4 > \text{HClO}_3 > \text{HClO}_2 > \text{HClO}$

The correct answer is option 2.

Q. 42 Which of the following is an analgesic ?

Option 1:

Novalgin

Option 2:

Penicillin

Option 3:

Streptomycin

Option 4:

Chloromycetin

Correct Answer:

Novalgin

Solution:

Analgesic -

Drugs which relieve or decrease pain are called analgesics.

- wherein

For eg: Aspirin and Analgin, etc.

Novalgin is analgesics and thus, reduces pain.

Q. 43 Natural rubber has:

Option 1:

All cis-configuration

Option 2:

All trans-configuration

Option 3:

Alternate cis-and trans-configuration

Option 4:

Random cis-and trans-configuration

Correct Answer:

All cis-configuration

Solution:

Natural Rubber/ cis-1 4-polyisoprene -

- It's an addition polymer of isoprene (2-methyl-1, 3-butadiene).
- Chains are held together by weak van der waal's interaction.
- wherein
- Sticky material.

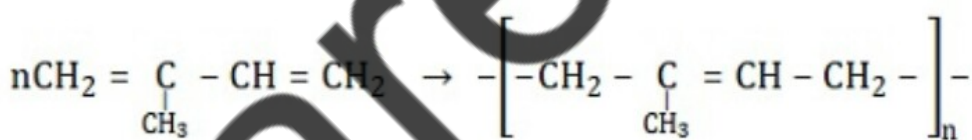

Isoprene
[2 - methyl butadiene]

Natural rubber
[Poly isoprene]

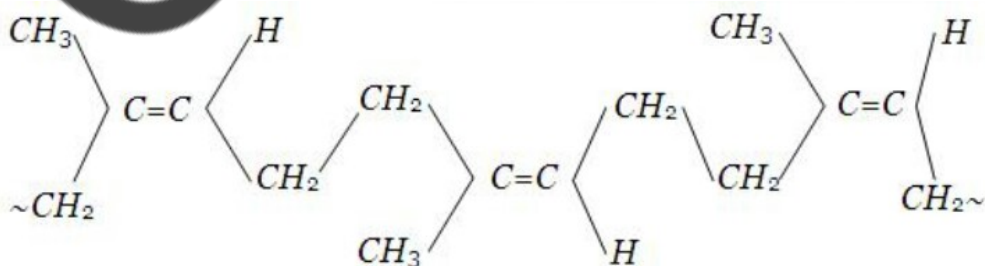

Natural rubber
All cis configuration

Q. 44 The ionic radii of A^+ and B^- ions are $0.98 \times 10^{-10} \text{ m}$ and $1.81 \times 10^{-10} \text{ m}$. The coordination number of each ion in AB is:

Option 1:

6

Option 2:

4

Option 3:

8

Option 4:

2

Correct Answer:

6

Solution:

As we learned in the concept

$$\text{Radius ratio of ions} = \frac{r_{\text{cation}}}{r_{\text{anion}}} = \frac{0.98}{1.81} = 0.541$$

This radius ratio lies between 0.441-0.732 which gives us the octahedral structure and coordination number 6.

Therefore, **Option(1) is correct.**

Q. 45 Which of the following has the longest C-O bond length? (Free C-O bond length in CO is 1.128 \AA)

Option 1:

$Ni(CO)_4$

Option 2:

$[Co(CO)_4]^-$

Option 3:

$[Fe(CO)_4]^{2-}$

Option 4:

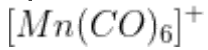

Correct Answer:

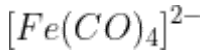

Solution:

Carbon monoxide is a strong field ligand as it accepts an electron density from metal into the π^* orbitals. Due to this back bonding bond length of the carbon-oxygen bond increases.

Bond length \propto negative charge

Bond length $\propto \frac{1}{\text{positive charge}}$

Bond length \propto number of d – electrons

$[Fe(CO)_4]^{2-}$ has the maximum length of the carbon-oxygen bond as the metal is carrying the highest negative charge and will show the most synergic or back bonding leading to an increase in Carbon-oxygen bond length and maximum.

Hence, the answer is the option (3).

Biology

Q. 1 Which of the following would appear as the pioneer organisms on bare rocks?

Option 1:

Lichens

Option 2:

Liverworts

Option 3:

Mosses

Option 4:

Green algae

Correct Answer:

Lichens

Solution:

As we have already studied in Ecological Succession -

The species that invade a bare area are called pioneer species. In primary succession on rocks, these are usually lichens which are able to secrete acids to dissolve rock, helping in weathering and soil formation.

Hence, the correct option is (a).

Q. 2 Water vapour comes out from the plant leaf through the stomatal opening. Through the same stomatal opening carbon dioxide diffuses into the plant during photosynthesis. Reason out the above statements using one of following options:

Option 1:

Both processes cannot happen simultaneously.

Option 2:

Both processes can happen together because the diffusion coefficient of water and CO_2 is different.

Option 3:

The above processes happen only during night time.

Option 4:

One process occurs during day time, and the other at night.

Correct Answer:

Both processes can happen together because the diffusion coefficient of water and CO_2 is different.

Solution:

As we learnt in

Rate of diffusion -

Rate \propto Temperature

Rate \propto steepness of diffusion pressure difference

$$\text{Rate} \propto \frac{1}{\sqrt{\text{Density of particle}}}$$

$$\text{Rate} \propto \frac{1}{\sqrt{\text{Size, mass of particle}}}$$

Diffusion of water vapour and CO_2 can occur simultaneously due to different diffusion coefficient.

Q. 3 Lack of relaxation between successive stimuli in sustained muscle contraction is known as:

Option 1:

Spasm

Option 2:

Fatigue

Option 3:

Tetanus

Option 4:

Tonus

Correct Answer:

Tetanus

Solution:

As we learnt in

Disorders Of Muscular And Skeletal System -

Tetany

- wherein

Rapid spasms (wild contractions) in muscle due to low Ca^{++} in body fluid.

The correct answer is (3) tetanus, This disease is caused by bacteria *Clostridium tetani*. The bacteria release a poison tetanospasmin in the body resulting in the blockage of nerve signals from the spinal cord to the muscles thus causing muscle spasms and results in lockjaw.

Q. 4 Depletion of which gas in the atmosphere can lead to an increased incidence of skin cancers:

Option 1:

Nitrous oxide

Option 2:

Ozone

Option 3:

Ammonia

Option 4:

Methane

Correct Answer:

Ozone

Solution:

As discussed in Ozone Depletion in the Stratosphere -

Degradation of ozone layers -

There should be a balance between production and degradation of ozone in the stratosphere. Of late, the balance has been disrupted due to enhancement of ozone degradation by chlorofluorocarbons (CFCs).

CFCs find wide use as refrigerants. CFCs discharged in the lower part of atmosphere move upward and reach stratosphere. In stratosphere, UV rays act on them releasing Cl atoms. Cl degrades ozone releasing molecular oxygen, with these atoms acting merely as catalysts; Cl atoms are not consumed in the reaction. Hence, whatever CFCs are added to the stratosphere, they have permanent and continuing affects on Ozone levels.

Hence, the correct option is (b).

Q. 5 Nomenclature is governed by certain universal rules. Which one of the following is contrary to the rules of nomenclature?

Option 1:

Biological names can be written in any language

Option 2:

The first word in a biological name represents the genus name, and the second is a specific epithet

Option 3:

The names are written in Latin and are italicised

Option 4:

When written by hand, the names are to be underlined separately

Correct Answer:

Biological names can be written in any language

Solution:

As we learnt in

Nomenclature -

Science of providing distinct and proper names to an organism.

- wherein

There is a need to standardize the naming of an organism, so that it is known by same name across the world.

Biological names are universal and cannot be written in any language.

Q. 6

A cell at telophase stage is observed by a student in a plant brought from the field. He tells his teacher that this cell is not like other cells at telophase stage. There is no formation of cell plate and thus the cell is containing more number of chromosomes as compared to other dividing cells. This would result in:

Option 1:

Aneuploidy

Option 2:

Polyploidy

Option 3:

Somaclonal variation

Option 4:

Polyteny

Correct Answer:

Polyploidy

Solution:

As we learnt in

Euploidy -

Type of chromosomal numerical mutation due to gain or loss of one or more genomes

- wherein

2 types

1. Hypoploidy
2. polyploidy

Polyploidy cells have a chromosome number that is more than double the haploid number.

Q. 7 The two polypeptides of human insulin are linked together by:

Option 1:

Hydrogen bonds

Option 2:

Phosphodiester bond

Option 3:

Covalent bond

Option 4:

Disulphide bridges

Correct Answer:

Disulphide bridges

Solution:

As we learnt in

Humulin -

On July 5, 1983, an American firm Eli Lilly launched a product know as Humulin. Insulin is a protein hormone, contains 51 amino acid arranged in two chains, bearing 21 and 30 amino acids. Human insulin consists of two polypeptides chains held together by disulphide bonds.

Q. 8 Reduction in pH of blood will:

Option 1:

reduce the rate of heart beat.

Option 2:

reduce the blood supply to the brain.

Option 3:

decrease the affinity of hemoglobin with oxygen.

Option 4:

release bicarbonate ions by the liver.

Correct Answer:

decrease the affinity of hemoglobin with oxygen.

Solution:

Oxygen Transport and Oxygen Dissociation Curve -

- Blood is the medium of transport for O_2 and CO_2 .
- About 97 percent of O_2 is transported by RBCs in the blood.
- The remaining 3 percent of O_2 is carried in a dissolved state through the plasma.
- Haemoglobin is a red coloured iron-containing pigment present in the RBCs.
- O_2 can bind with haemoglobin in a reversible manner to form oxyhaemoglobin. This is called O₂-Hb association.
- Each haemoglobin molecule can carry a maximum of four molecules of O_2 .
- Binding of oxygen with haemoglobin is primarily related to the partial pressure of O_2 .

As we learnt in

Oxygen Dissociation Curve -

A sigmoid curve is obtained when percentage saturation of haemoglobin with O_2 is plotted against the PO_2 . This curve is called the Oxygen dissociation curve and is highly useful in studying the effect of factors like PCO_2 , H^+ concentration, etc., on binding of O_2 with haemoglobin.

- wherein

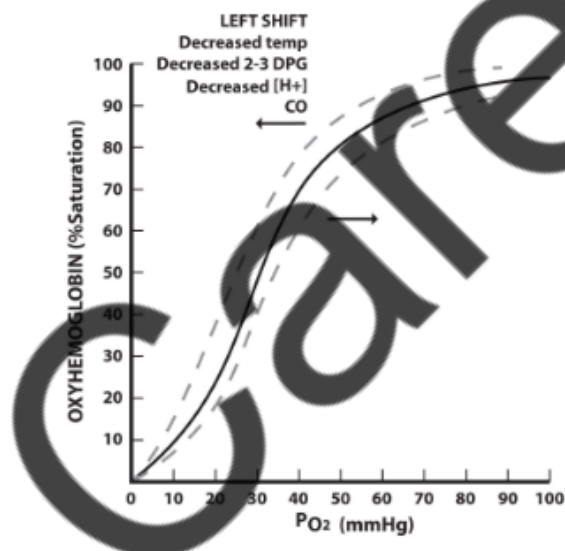

High concentration of H^+ will reduce the pH, which will decrease the affinity of Hb with O_2 .

Q. 9 In a chloroplast the highest number of protons are found in:

Option 1:

Stroma

Option 2:

Lumen of thylakoids

Option 3:

Inter membrane space

Option 4:

Antennae complex

Correct Answer:

Lumen of thylakoids

Solution:

According to chemiosmotic hypothesis, ATP synthesis is linked to the development of a proton gradient across the membrane of the thylakoid. The splitting of the water molecule takes place on the inner side of the membrane and so the hydrogen ions (protons) that are produced, they accumulate within the lumen of the thylakoids. So, the highest number of protons are found in lumen of thylakoids in chloroplast.

Q. 10 Which type of tissue correctly matches with its location?

Tissue	Location
--------	----------

Option 1:

Smooth muscle	Wall of intestine
---------------	-------------------

Option 2:

Areolar tissue	Tendons
----------------	---------

Option 3:

Transitional epithelium	Tip of nose
-------------------------	-------------

Option 4:

Cuboidal epithelium	Lining of stomach
---------------------	-------------------

Correct Answer:

Smooth muscle

Wall of intestine

Solution:

Areolar tissue is present in the skin and binds the outer layers of skin to the muscles beneath.

Transitional epithelium forms the lining of the wall of urinary bladder.

Cuboidal epithelium is commonly found in ducts of glands and tubular parts of nephrons in kidneys and its main function is absorption and secretion.

The wall of intestine is formed by smooth muscles which are non-striated and involuntary.

Hence, the correct answer is option a.

Q. 11 Which of the following pairs of hormones are not antagonistic (having opposite effects) to each other?

Option 1:

Parathormone - Calcitonin

Option 2:

Insulin - Glucagon

Option 3:

Aldosterone - Atrial Natriuretic Factor

Option 4:

Relaxin - Inhibin

Correct Answer:

Relaxin - Inhibin

Solution:

The non-antagonistic pair of hormones is:

Option 4) Relaxin - Inhibin

Relaxin and inhibin are both peptide hormones, but they have different functions and are not antagonistic to each other. Relaxin is primarily involved in the relaxation of smooth muscles and the regulation of reproductive processes, while inhibin is involved in the inhibition of follicle-stimulating hormone (FSH) secretion.

Option 1) Parathormone - Calcitonin: Parathormone and calcitonin are antagonistic hormones involved in the regulation of calcium and phosphate levels in the body.

Option 2) Insulin - Glucagon: Insulin and glucagon are antagonistic hormones involved in the regulation of blood sugar levels. Insulin decreases blood sugar levels, while glucagon increases blood sugar levels.

Option 3) Aldosterone - Atrial Natriuretic Factor: Aldosterone and atrial natriuretic factor (ANF) are antagonistic hormones involved in the regulation of blood pressure and sodium balance in the body.

Q. 12 In mammals, which blood vessel would normally carry largest amount of urea?

Option 1:
Renal Vein

Option 2:
Dorsal Aorta

Option 3:
Hepatic Vein

Option 4:
Hepatic Portal Vein

Correct Answer:
Hepatic Vein

Solution:

Urea is synthesized in the liver maximum amount of urea is present in hepatic vein & urinal in renal Vein.

Q. 13 Pick out the correct statements:

- (a) Haemophilia is a sex-linked recessive disease.
- (b) Down's syndrome is due to aneuploidy.
- (c) Sickle cell anaemia is an X-linked recessive gene disorder.
- (d) Phenylketonuria is an autosomal recessive gene disorder.

Option 1:
(a) and (d) are correct.

Option 2:
(b) and (d) are correct.

Option 3:
(a), (c) and (d) are correct.

Option 4:
(a), (b) and (d) are correct.

Correct Answer:
(a), (b) and (d) are correct.

Solution:

(a) Haemophilia is a sex-linked recessive disease. The abnormal gene responsible for haemophilia is carried on the X chromosome.

(b) Down's syndrome is due to aneuploidy. Down Syndrome is a disorder that results from an extra copy of 1 chromosome.

(c) Phenylketonuria is an autosomal recessive gene disorder. It caused by mutations in both alleles of the gene for phenylalanine hydroxylase (PAH), found on chromosome 12.

(d) Sickle cell anaemia is an autosomal recessive disorder. Two copies of the gene must be mutated for a person to be affected by an autosomal recessive disorder.

Hence, the statements a, b and c are correct.

Q. 14 Which of the following approaches does not give the defined action of contraceptive?

Option 1:

Barrier methods	prevent fertilization
-----------------	-----------------------

Option 2:

Intra uterine devices	increase phagocytosis of sperms, suppress sperm motility and fertilizing capacity of sperms
-----------------------	---------------------------------------------------------------------------------------------

Option 3:

Hormonal contraceptives	Prevent/ retard entry of sperms, prevent ovulation and fertilization
-------------------------	----------------------------------------------------------------------

Option 4:

Vasectomy	prevents spermatogenesis
-----------	--------------------------

Correct Answer:

Vasectomy	prevents spermatogenesis
-----------	--------------------------

Solution:

- Barrier methods are the one that prevents sperms from reaching the egg and thereby inhibit fertilization.

- Copper-releasing IUDs release copper that suppresses the sperm motility which in turn reduces its fertilizing capacity. IUDs, that release levonorgestrel (LNG), cause endometrial atrophy and alter the stroma to inhibit implantation. It also increases sperm phagocytosis in the uterus. Oral contraceptive pills contain small doses of estradiol or progesterone.
- The higher blood level of progesterone exerts negative feedback on FSH and LH secretion by anterior pituitary which are the enzymes of follicle maturation and ovulation. Thus, contraceptive pills inhibit ovulation.
- Vasectomy refers to a surgical method in which vasa deferentia in human males are cut and sealed to prevent pregnancy by making seminal fluid devoid of sperms.

Hence, the correct answer is 'Vasectomy-prevents spermatogenesis'

Q. 15 Which one of the following characteristics is not shared by birds and mammals?

Option 1:

Ossified endoskeleton

Option 2:

Breathing using lungs

Option 3:

Viviparity

Option 4:

Warm blooded nature

Correct Answer:

Viviparity

Solution:

As we learnt in

Class Aves (Birds) -

Characterised by the presence of feathers and most of them can fly. They possess beak and forelimbs are modified into wings.

- wherein

Eg. Corvus, Columba, Psittacula, Struthio, Pavo.

AND

Class Mammalia -

Unique characteristic is presence of mammary glands. Two pairs of limbs and external ears or pinnae present.

-

Birds are oviparous while mammals are oviparous (prototherians) and viviparous (metatherians and eutherians).

Q. 16 Emerson's enhancement effect and Red drop have been instrumental in the discovery of:

Option 1:

Photophosphorylation and non-cyclic electron transport

Option 2:

Two photosystems operating simultaneously

Option 3:

Photophosphorylation and cyclic electron transport

Option 4:

Oxidative phosphorylation

Correct Answer:

Two photosystems operating simultaneously

Solution:

As we learnt in

Red Drop -

Sharp reduction in rate of photosynthesis when monochromatic light of more than 680 nm wavelength (red region) was used alone.

Emerson Enhancement Effect -

Simultaneous application of light of shorter and longer wavelengths, increases the rate of photosynthesis.

$680 \downarrow + 680nm \uparrow$ - Emerson Effect

Hence, Emerson's Enhancement effect and Red drop are due to the presence of two photosystems PS I and PS II.

Q. 17 In which of the following, all three are macronutrients?

Option 1:

Boron, zinc, manganese

Option 2:

Iron, copper, molybdenum

Option 3:

Molybdenum, magnesium, manganese

Option 4:

Nitrogen, nickel, phosphorus

Correct Answer:

Nitrogen, nickel, phosphorus

Solution:

Macronutrients are the nutrients that plants need in large quantities, and the soil provides them to plants in relatively large quantities.

- **Nitrogen** is used in the synthesis of various vitamins and is also a component of protein and nucleic acids.
- **Nickel is a macronutrient that also helps legumes fix nitrogen by acting as a catalyst and is a major component of enzymes.**
- In addition to being a macronutrient that is found in nucleic acids, **phosphorus** also plays a crucial role in metabolism.
- Macronutrients are all three of them.

Hence, option 4 is the correct answer.

Q. 18 Changes in GnRH pulse frequency in females is controlled by circulating levels of:

Option 1:

estrogen and progesterone

Option 2:

estrogen and inhibin

Option 3:

progesterone only

Option 4:

progesterone and inhibin

Correct Answer:

estrogen and progesterone

Solution:

Gonadotropin-releasing hormone (GnRH) is produced by the hypothalamus. It stimulates the pituitary gland to produce luteinizing hormone (LH) and, to a lesser extent, follicle-stimulating hormone (FSH). However, with depletion of the follicular number, estrogen levels decrease with subsequent loss of

negative feedback and resultant increases in GnRH secretion. Progesterone also decreases GnRH secretion at the level of the hypothalamus.

Hence, the correct answer is 'estrogen and progesterone'

Q. 19 The coconut water from tender coconut represents:

Option 1:
Endocarp

Option 2:
Fleshy mesocarp

Option 3:
Free nuclear proembryo

Option 4:
Free nuclear endosperm

Correct Answer:
Free nuclear endosperm

Solution:

As discussed in concept

free-nuclear endosperm -

During endosperm development, the PEN undergoes successive nuclear divisions to give rise to free nuclei. This stage of endosperm development is called free-nuclear endosperm

- wherein

e.g., The coconut water from tender coconut that is a free-nuclear endosperm

Coconut water from tender coconut is free nuclear endosperm.

Q. 20 Which of the following guards the opening of hepatopancreatic duct into the duodenum?

Option 1:
Semilunar valve

Option 2:
Ileocaecal valve

Option 3:
Pyloric sphincter

Option 4:

Sphincter of Oddi

Correct Answer:

Sphincter of Oddi

Solution:

As we learnt in

Hepato-pancreatic duct -

The bile duct and the pancreatic duct open together into the duodenum as the common hepato-pancreatic duct

- wherein

It is guarded by a sphincter called the sphincter of Oddi.

Hepatopancreatic duct is guarded by sphincter of Oddi.

Q. 21 Which one of the following is the starter codon?

Option 1:

AUG

Option 2:

UGA

Option 3:

UAA

Option 4:

UAG

Correct Answer:

AUG

Solution:

As we learnt in

Salient features of genetics code -

1. The codon is triplet, 61 codons code for amino acids and 3 codons do not code for any amino acids, hence they function as stop codons.

- wherein

		Second base				
		U	C	A	G	
First base	U	UUU } Phenylalanine F UUC } UUA } Leucine L UUG }	UCU } Serine S UCC } UCA } UCG }	UAU } Tyrosine Y UAC } UAA } Stop codon UAG } Stop codon	UGU } Cysteine C UGC } UGA } Stop codon UGG } Tryptophan W	U C A G
	C	CUU } Leucine L CUC } CUA } CUG }	CCU } Proline P CCC } CCA } CCG }	CAU } Histidine H CAC } CAA } Glutamine Q CAG }	CGU } Arginine R CGC } CGA } CGG }	U C A G
	A	AUU } Isoleucine I AUC } AUA } AUG } Methionine start codon M	ACU } Threonine T ACC } ACA } ACG }	AAU } Asparagine N AAC } AAA } Lysine K AAG }	AGU } Serine S AGC } AGA } Arginine R AGG }	U C A G
	G	GUU } Valine V GUC } GUA } GUG }	GCU } Alanine A GCC } GCA } GCG }	GAU } Aspartic acid D GAC } GAA } Glutamic acid E GAG }	GGU } Glycine G GGC } GGA } GGG }	U C A G

Hence, AUG is the start codon.

Q. 22 Spindle fibres attach on to:

Option 1:

Telomere of the chromosome

Option 2:

Kinetochores of the chromosome

Option 3:

Centromere of the chromosome

Option 4:

Kinetosome of the chromosome

Correct Answer:

Kinetochores of the chromosome

Solution:

As we learnt in

Metaphase -

Second phase of cell division marks the complete disintegration of the nuclear envelope. Spindle fibres attach to the kinetochore of chromosomes.

Chromosomes move to spindle equator and get aligned along metaphase plate through spindle equator and get aligned along metaphase plate through spindle fibres to both poles

- wherein

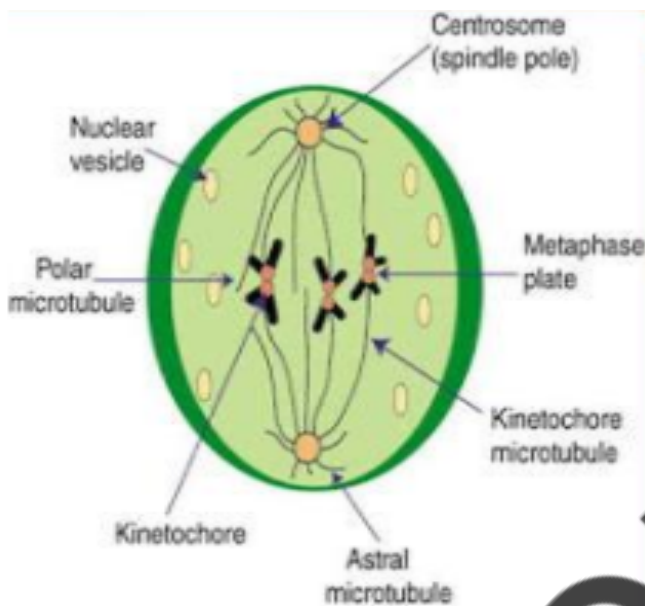

Spindle fibres are attached to kinetochore of chromosomes during metaphase.

Q. 23 A tall true breeding garden pea plant is crossed with a dwarf true breeding garden pea plant. When the F_1 plants were selfed the resulting genotypes were in the ratio of:

Option 1:

1 : 2 : 1 :: Tall homozygous : Tall heterozygous : Dwarf

Option 2:

1 : 2 : 1 :: Tall heterozygous : Tall homozygous : Dwarf

Option 3:

3 : 1 Tall : Dwarf

Option 4:

3 : 1 :: Dwarf : Tall

Correct Answer:

1 : 2 : 1 :: Tall homozygous : Tall heterozygous : Dwarf

Solution:

As we learnt in

Conclusion from punnett square -

All F_1 are tall and in F_2 3/4th of the plants are tall.

Thus, phenotypic ratio of 3/4th tall: (1/4TT + 1/2Tt) and 1/4th tt, i.e 3:1 ratio but genotypic ratio of 1:2:1

Q. 24 A typical fat molecule is made up of:

Option 1:

Three glycerol molecules and one fatty acid molecule

Option 2:

One glycerol and three fatty acid molecules

Option 3:

One glycerol and one fatty acid molecule

Option 4:

Three glycerol and three fatty acid molecules

Correct Answer:

One glycerol and three fatty acid molecules

Solution:

As we learnt in

Oils and fats -

The monoglycerides, diglycerides and triglycerides can be classified into oils and fats based on their melting points.

- wherein

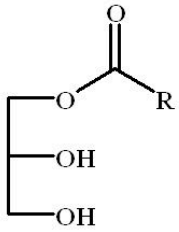

MONOGLYCERIDE

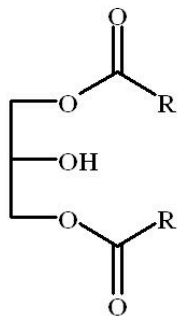

DIGLYCERIDE

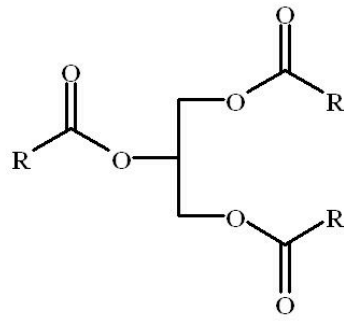

TRIGLYCERIDE

Fats are triglyceride formed by esterification of one glycerol and three fatty acids.

Q. 25 A system of rotating crops with legume or grass pasture to improve soil structure and fertility is called:

Option 1:

Ley farming

Option 2:

Contour farming

Option 3:

Strip farming

Option 4:

Shifting agriculture

Correct Answer:

Ley farming

Solution:

ley farming is the the alternate growing of crops and grass.ley farming is the the alternate growing of crops and grass.

Q. 26 Which of the following is **not** a stem modification?

Option 1:

Pitcher of *Nepenthes*

Option 2:

Thorns of citrus

Option 3:

Tendrils of cucumber

Option 4:

Flattened structures of *Opuntia*

Correct Answer:

Pitcher of *Nepenthes*

Solution:

A. The pitcher of *Nepenthes* is the modification of leaf lamina which takes the form of pitcher to trap insects.

B. Thorns of citrus are modified stem which performs the function of climbing or defense. Thorns are present in the axil of leaves or apex of stem.

C. A tendril of cucumber is modified stem which is formed by the modification of terminal bud into tendril because the stem is often weak in such plants.

Hence, thorns of citrus and tendrils of cucumber are stem modifications while pitcher of *Nepenthes* is leaf modification.

So, the correct answer is 'Pitcher of *Nepenthes*'.

Q. 27 Which of the following features is **not** present in *Periplaneta americana*?

Option 1:

Schizocoelom as body cavity

Option 2:

Indeterminate and radial cleavage during embryonic development

Option 3:

Exoskeleton composed of N-acetylglucosamine

Option 4:

Metamerically segmented body

Correct Answer:

Indeterminate and radial cleavage during embryonic development

Solution:

Indeterminate and radial cleavage is not the feature of cockroach (*Periplaneta Americana*) as it is the feature of deuterostomes and cockroaches are protostomes which have spiral and determinate cleavage. Thus, the correct answer is option b.

Q. 28 Name the chronic respiratory disorder caused mainly by cigarette smoking:

Option 1:

Emphysema

Option 2:

Asthma

Option 3:

Respiratory acidosis

Option 4:

Respiratory alkalosis

Correct Answer:

Emphysema

Solution:

As we learnt in

DISORDERS OF RESPIRATORY SYSTEM -

Emphysema

- wherein

Emphysema is a chronic disorder in which alveolar walls are damaged due to which respiratory surface is decreased. One of the major causes of this is cigarette smoking.

Q. 29 Which one of the following statements is **not** true?

Option 1:

Tapetum helps in the dehiscence of anther

Option 2:

Exine of pollen grains is made up of sporopollenin

Option 3:

Pollen grains of many species cause severe allergies

Option 4:

Stored pollen in liquid nitrogen can be used in the crop breeding programmes

Correct Answer:

Tapetum helps in the dehiscence of anther

Solution:

As we learnt in

Function of wall layers in a typical microsporangium -

The outer three wall layers perform the function of protection and help in dehiscence of anther to release the pollen. The innermost wall layer is the tapetum. It nourishes the developing pollen grains. Cells of the tapetum possess dense cytoplasm and generally have more than one nucleus.

-

Tapetum provides nourishment to the developing pollen grains

Q. 30 Which of the following is required as inducer(s) for the expression of Lac operon?

Option 1:

glucose

Option 2:

galactose

Option 3:

lactose

Option 4:

lactose and galactose

Correct Answer:

lactose

Solution:

In the presence of lactose, allolactose; an isomer of lactose, binds to the repressor and causes an allosteric shift. The altered repressor cannot bind to the operator, allowing RNA polymerase to transcribe the lac genes. Thus lactose is required for expression of the lac operon.

Hence, the correct answer is 'Lactose'

Q. 31 Mitochondria and chloroplast are:

- a. semi-autonomous organelles.
- b. formed by division of pre-existing organelles and they contain DNA but lack protein synthesizing machinery.

Which one of the following options is correct?

Option 1:

Both (a) and (b) are correct.

Option 2:

(b) is true but (a) is false.

Option 3:

(a) is true but (b) is false.

Option 4:

Both (a) and (b) are false.

Correct Answer:

(a) is true but (b) is false.

Solution:

Mitochondria and chloroplasts are semi-autonomous organelles. These are formed by division of pre-existing organelles and they contain DNA as well as protein synthesizing machinery. However, they are not capable of synthesizing full-range of functional proteins and have to depend on nuclear genes and cytoplasmic protein synthesizing machinery. Hence, only statement a is correct.

Q. 32 It is much easier for a small animal to run uphill than for a large animal, because

Option 1:

It is easier to carry a small body weight

Option 2:

Smaller animals have a higher metabolic rate

Option 3:

Small animals have a lower O₂ requirement

Option 4:

The efficiency of muscles in large animals is less than in the small animals

Correct Answer:

Smaller animals have a higher metabolic rate

Solution:

As we learnt in

Metabolism -

Sum total of all reaction occurring in organism.

- wherein

Includes anabolism and catabolism.

Metabolism results in release of energy. Metabolic rate is directly proportional to the size of an animal. Hence, smaller animals have more energy due to high metabolic rate.

Q. 33 Seed formation without fertilization in flowering plants involves the process of:

Option 1:

Sporulation

Option 2:

Budding

Option 3:

Somatic hybridization

Option 4:

Apomixis

Correct Answer:

Apomixis

Solution:

As we have learnt in -

Apomixis:

- Apomixis (Gk. apo- without, mixis- mixing) is a mode of reproduction which does not involve the formation of zygote through gametic fusion.
- Hence, there is no fertilization involved.
- In plants apomixis commonly mimics sexual reproduction but produces seeds without fertilisation, e.g., some species of Asteraceae and grasses.
- It is of following types:
 - Agamospermy
 - Adventive embryony

- Hence, the correct answer is (d).

Q. 34 The *Avena* curvature is used for bioassay of:

Option 1:

ABA

Option 2:

GA₃

Option 3:

IAA

Option 4:
Ethylene

Correct Answer:
IAA

Solution:

As we have learnt in:

Avena Curvature Test for bioassay of auxin:

- This test is based on the experiments done by Went.
- This test is based on the polar transport of auxin in Avena coleoptile.
- The auxin applied on one side of the cut coleoptile stump will diffuse down that side only and will cause that side to grow more resulting in curvature of the coleoptiles.
- Within limits, this curvature is directly proportional to the amount of auxin applied.
- 100 curvature is produced by auxin concentration of 150 micrograms per litre at 25°C.

-

Q. 35 A plant in your garden avoids photorespiratory losses, has improved water use efficiency, shows high rates of photosynthesis at high temperatures and has improved efficiency of nitrogen utilisation. In which of the following physiological groups would you assign this plant?

Option 1:
C₃

Option 2:
C₄

Option 3:
CAM

Option 4:
Nitrogen fixer

Correct Answer:
C₄

Solution:

In C_4 pathway, photorespiration is negligible and rate of photosynthesis is increased at higher temperature. Hence, the correct answer is option b.

Q. 36 Which is the National Aquatic Animal of India?

Option 1:

Gangetic shark

Option 2:

River dolphin

Option 3:

Blue whale

Option 4:

Sea - horse

Correct Answer:

River dolphin

Solution:

National aquatic animal of India is river dolphin.

Q. 37 Which of the following is **not** a feature of the plasmids?

Option 1:

Independent replication

Option 2:

Circular structure

Option 3:

Transferable

Option 4:

Single-stranded

Correct Answer:

Single-stranded

Solution:

As we learnt in

Plasmids -

A plasmid is a small, circular double stranded DNA molecules; has power of self replication. They usually exist in bacteria and some lower eukaryotes. They have antibiotic resistance gene.

- wherein

Plasmids provide genetic advantages like antibiotic resistance.

Plasmids are double stranded circular structure.

Q. 38 The amino acid Tryptophan is the precursor for the synthesis of :

Option 1:

Melatonin and Serotonin

Option 2:

Thyroxine and Triiodothyronine

Option 3:

Estrogen and Progesterone

Option 4:

Cortisol and Cortisone

Correct Answer:

Melatonin and Serotonin

Solution:

Amino and tryptophan is an essential amino acid. It is a precursor of neurotransmitter serotonin and hormone melatonin

Q. 39 Joint Forest Management Concept was introduced in India during:

Option 1:

1960s

Option 2:

1970s

Option 3:

1980s

Option 4:

1990s

Correct Answer:

1980s

Solution:

As we have already studied in Case Study of People's Participation in Conservation of Forests -

JFM is a programme launched by Government of India in 1988 and guidelines issued in 1990. It aims at establishing a partnership between local communities and state forest departments. Hence, the correct answer is '1980s'

Hence, the correct option is (c).

Q. 40 Water soluble pigments found in plant cell vacuoles are:

Option 1:

Xanthophylls

Option 2:

Chlorophylls

Option 3:

Carotenoids

Option 4:

Anthocyanins

Correct Answer:

Anthocyanins

Solution:

Anthocyanins are present in the vacuole of the plant cells and these are water soluble.

Q. 41 Which one of the following is a characteristic feature of cropland ecosystem?

Option 1:

Absence of soil organisms

Option 2:

Least genetic diversity

Option 3:

Absence of weeds

Option 4:
Ecological succession

Correct Answer:
Least genetic diversity

Solution:

Cropland ecosystem is the largest anthropogenic ecosystem characterised by less diversity and high productivity. **Least genetic diversity** is a characteristic feature of cropland ecosystem.

A cropland ecosystem will have a major crop cultivated in a given area. It shows that the diversity in that particular area will be least. Whereas it is the opposite when the forest ecosystem is considered.

Q. 42 Which of the following characteristic features always holds true for the corresponding group of animals?

Option 1:

Cartilaginous endoskeleton	Chondrichthyes
----------------------------	----------------

Option 2:

Viviparous	Mammalia
------------	----------

Option 3:

Possess a mouth with an upper and a lower jaw	Chordata
-----------------------------------------------	----------

Option 4:

3-chambered heart with one incompletely divided ventricle	Reptilia
-----------------------------------------------------------	----------

Correct Answer:

Cartilaginous endoskeleton	Chondrichthyes
----------------------------	----------------

Solution:

Chondrichthyes is a class that contains the cartilaginous fishes: they are jawed vertebrates with paired fins, paired nares, scales, a heart with its chambers in series, and skeletons made of cartilage rather than bone.

Viviparous - Giving birth to living young that develop within the mother's body rather than hatching from eggs. It is the characteristic feature of mammals.

Chordata - Possess a mouth with an upper and lower jaw.

All reptiles have three-chambered hearts, except crocodiles, which have four-chambered hearts (2 atria, 2 ventricles), like mammals and birds. Reptiles have a digestive system which has a muscular opening at the base of the tail.

Q. 43 The primitive prokaryotes responsible for the production of biogas from the dung of ruminant animals, include the:

Option 1:
Halophiles

Option 2:
Thermoacidophiles

Option 3:
Methanogens

Option 4:
Eubacteria

Correct Answer:
Methanogens

Solution:

As we learnt in

Methanogens -

- Autotrophs
- Obligate anaerobes
- Gram negative bacteria
- Produce methane gas from CO₂ or formic acid
- Lives in digestive tracks of grazing animals and rotten selvage.

- wherein

Eg. Methanococcus

Methanobacterium

Q. 44 Antivenom injection contains preformed antibodies while polio drops that are administered into the body contain:

Option 1:

Activated pathogens

Option 2:

Harvested antibodies

Option 3:

Gamma globulin

Option 4:

Attenuated pathogens

Correct Answer:

Attenuated pathogens

Solution:

Antivenom injection is an antiserum (preformed antibodies) which is obtained from the snake poison and it is transferred to the person with a snake bite. It is used to provide immediate immunity in case of emergency. Polio vaccines are vaccines used to prevent poliomyelitis (polio). Two types are used - an inactivated poliovirus (antigen) given by injection and an attenuated poliovirus (antigen) given by mouth.

Hence, the correct answer is 'attenuated pathogens'

Q. 45 When does the growth rate of a population following the logistic model equal zero? The logistic model is given as $dN/dt = rN(1-N/K)$:

Option 1:

when N/K is exactly one.

Option 2:

when N nears the carrying capacity of the habitat.

Option 3:

when N/K equals zero.

Option 4:

when death rate is greater than birth rate.

Correct Answer:

when N/K is exactly one.

Solution:

The equation for logistic growth -

A plot of N in relation to time (t) results in a sigmoid curve. This type of population growth is called Verhulst-Pearl Logistic Growth and is described by the following equation:

- wherein

$$d\frac{N}{dt} = \frac{rN(K - N)}{K}$$

Where,

N = Population density at time t

r = Intrinsic rate of natural increase

K = Carrying capacity

So, the growth rate of the population will be equal to zero, when the value of N/K is equal to one.

Hence, the correct answer is 'when N/K is exactly one.'

Q. 46 Which one of the following statements is wrong?

Option 1:

Sucrose is a disaccharide.

Option 2:

Cellulose is a polysaccharide.

Option 3:

Uracil is a pyrimidine.

Option 4:

Glycine is a sulphur containing amino acid.

Correct Answer:

Glycine is a sulphur containing amino acid.

Solution:

As we learnt in

Amino acids that occur in proteins -

The R-group in proteinaceous amino acids could be

Hydrogen- amino acids is called glycine

methyl group -alanine, and

hydroxyl methyl - serine

- wherein

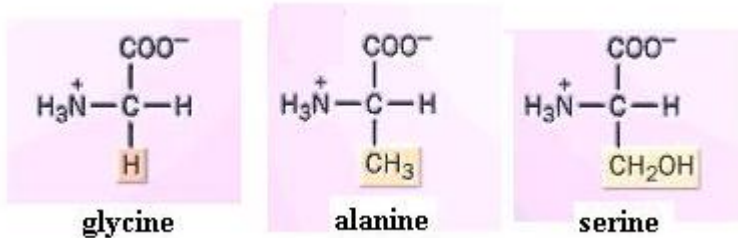

Glycine is simplest amino acid with hydrogen as side group.

Q. 47 The taq polymerase enzyme is obtained from:

Option 1:

Thermus aquaticus

Option 2:

Thiobacillus ferrooxidans

Option 3:

Bacillus subtilis

Option 4:

Pseudomonas putida

Correct Answer:

Thermus aquaticus

Solution:

Tag polymerase is obtained from Thermophilous aquaticus. Hence, the correct option is (a).

Q. 48 Gause's principle of competitive exclusion states that:

Option 1:

More abundant species will exclude the less abundant species through competition.

Option 2:

Competition for the same resources excludes species having different food preferences.

Option 3:

No two species can occupy the same niche indefinitely for the same limiting resources.

Option 4:

Larger organisms exclude smaller ones through competition.

Correct Answer:

No two species can occupy the same niche indefinitely for the same limiting resources.

Solution:

As we learnt in

Competitive Exclusion Principle -

Two closely related species competing for the same resources cannot co-exist indefinitely and the competitively inferior one will be eliminated eventually. Gause's law of competitive exclusion or just Gause's law is a proposition that states that two species competing for the same resource cannot coexist at constant population values if other ecological factors remain constant. When two competing life forms attempt to occupy the same niche, only one outcome is possible: One life form will drive out the other.

Hence, the correct answer is 'No two species can occupy the same niche indefinitely for the same limiting resources.'

Q. 49 Stems modified into flat green organs performing the functions of leaves are known as:

Option 1:

Cladodes

Option 2:

Phyllodes

Option 3:

Phylloclades

Option 4:

Scales

Correct Answer:

Phylloclades

Solution:

As we learnt in

Types of special stem modifications -

Phyllacodes - Flat, fleshy, green leaf like structure which has a succession of nodes and internodes at long and short intervals. Leaves are modified into spine or scale to check transpiration. Photosynthesis takes place in phyllacodes. Ex: Opuntia, cereus, Euphorbia

Cladode - Phylloclade with one internode is called cladode. Ex: Asparagus & Ruscus

Thorn - Modification of axillary bud or terminal bud of the stem. It may bear leaves, flowers & Endogenous in origin. Ex: Catissa (Karonda), pomegranate, citrus, Bougainvillae

Tendrils - Helps the plant to climb, When it comes in contact with the neighbouring object it coils round it. It is modification of axillary bud and exogenous in origin. Ex: Grapes, cucumber, pumkins, watermelon etc

-

Q. 50 Which part of the tobacco plant is infected by *Meloidogyne incognita*?

Option 1:
Flower

Option 2:
Leaf

Option 3:
Stem

Option 4:
Root

Correct Answer:
Root

Solution:

As we learnt in-

Roots of the tobacco plants are infected. RNAi (Interference RNA) method is used to develop resistance against infection. Antisense RNA is a single-stranded RNA that is complementary to a protein-coding messenger RNA (mRNA) that hybridize with it and blocks protein translation.

Hence, the correct answer is 'root'

Q. 51 Fertilization in humans is practically feasible only if:

Option 1:

the sperms are transported into vagina just after the release of ovum in fallopian tube.

Option 2:

the ovum and sperms are transported simultaneously to ampullary-isthmic junction of the fallopian tube.

Option 3:

the ovum and sperms are transported simultaneously to ampullary-isthmic junction of the cervix.

Option 4:

the sperms are transported into cervix within 48 hrs of release of ovum in uterus.

Correct Answer:

the ovum and sperms are transported simultaneously to ampullary-isthmic junction of the fallopian tube.

Solution:

As we learnt in

Process of Fertilisation -

The motile sperms swim rapidly, pass through the cervix, enter into the uterus and finally reach the ampullary region of the fallopian tube. The ovum released by the ovary is also transported to the ampullary region where fertilisation takes place. Fertilisation can only occur if the ovum and sperms are transported simultaneously to the ampullary region. This is the reason why not all copulations lead to fertilisation and pregnancy. Fertilisation takes place in the ampullary region of fallopian tube.

Hence, the correct answer is option b

Q. 52 Which of the following statements is **not** true for cancer cells in relation to mutations?

Option 1:

Mutations in proto-oncogenes accelerate the cell cycle.

Option 2:

Mutations destroy telomerase inhibitor.

Option 3:

Mutations inactivate the cell control.

Option 4:

Mutations inhibit production of telomerase.

Correct Answer:

Mutations inhibit production of telomerase.

Solution:

As we learnt in

Cancer -

Cancer is one of the most dreaded diseases of human beings and is a major cause of death all over the globe.

- wherein

In our body, cell growth and differentiation is highly controlled and regulated. In cancer cells, there is breakdown of these regulatory mechanisms

Cancerous cells have a high telomerase activity.

Q. 53 Which of the following structures is homologous to the wing of a bird?

Option 1:

Dorsal fin of a Shark

Option 2:

Wing of a Moth

Option 3:

Hind limb of Rabbit

Option 4:

Flipper of Whale

Correct Answer:

Flipper of Whale

Solution:

Homologous Organs -

Organs which look different and perform different functions, but have similar basic structure, similar topography and embryonic origin. These are called homologous organs. Eg: forelimbs of vertebrates like the seal, bat, bird wings, dragonfly, pterodactyl, eagle, humorous bat.

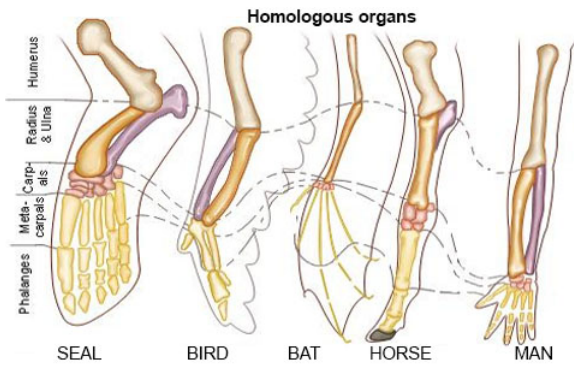

Hence, the correct answer is 'Wing of a bird is homologous to flipper of the whale'

Q. 54 Match the terms in **Column I** with their description in **Column II** and choose the correct option:

Column I	Column II
(a) Dominance	(i) Many genes govern a single character
(b) Codominance	(ii) In a heterozygous organism only one allele expresses itself
(c) Pleiotropy	(iii) In a heterozygous organism both alleles express themselves fully
(d) Polygenic inheritance	(iv) A single gene influences many characters

Codes:

(a) (b) (c) (d)

Option 1:

(ii) (i) (iv) (iii)

Option 2:

(ii) (iii) (iv) (i)

Option 3:

(iv) (i) (ii) (iii)

Option 4:

(iv) (iii) (i) (ii)

Correct Answer:

(ii) (iii) (iv) (i)

Solution:

As we learnt in

Test cross between flowers -

In a typical test cross, an organism showing a dominant phenotype is crossed with recessive parent instead of self-crossing.

- wherein

The result of typical test cross between a violet flower (W) is dominant over white flower (w) is dominant over white flower (w) is shown.

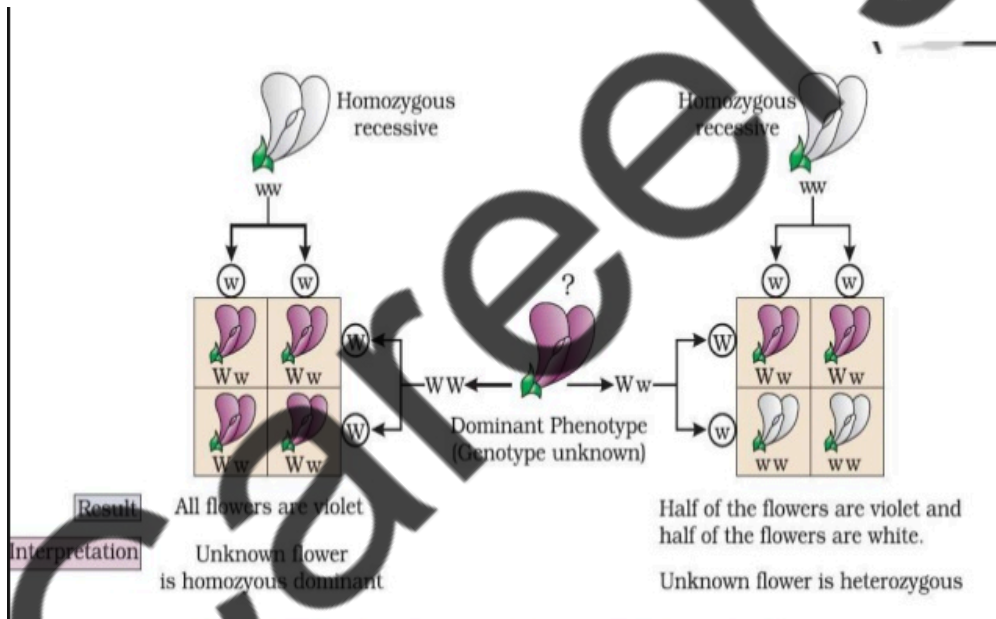

Co-dominance explained in red-blood cells -

Red-blood cells are controlled by gene (I). RBC's have sugar attached to surface which is controlled by the gene (I). The gene (I) has three alleles : I^A , I^B and i

- wherein

The allele of gene (I), I^A and I^B process sugar of different forms while *i* does not produce any.

Q. 55 Which of the following is **wrongly** matched in the given table?

	Microbe	Product	Application
--	---------	---------	-------------

Option 1:

<i>Trichoderma polysporum</i>	Cyclosporin A	Immunosuppressive drug
-------------------------------	---------------	------------------------

Option 2:

<i>Monascus purpureus</i>	Statins	Lowering blood cholesterol
---------------------------	---------	----------------------------

Option 3:

<i>Streptococcus</i>	Streptokinase	Removal of clot from blood vessel
----------------------	---------------	-----------------------------------

Option 4:

<i>Clostridium butylicum</i>	Lipase	Removal of oil stains
------------------------------	--------	-----------------------

Correct Answer:

<i>Clostridium butylicum</i>	Lipase	Removal of oil stains
------------------------------	--------	-----------------------

Solution:

As we have learnt in Chemicals, Enzymes and other Bioactive Molecules -

Lipases -

Microbes are also used for production of enzymes

- wherein

Lipases are used in detergent formulations and are helpful in removing oily stains from the laundry.

Clostridium butylicum is a gram positive bacteria.

Hence, the correct option is (d).

Q. 56 Select the incorrect statement :

Option 1:

FSH stimulates the sertoli cells which help in spermiogenesis.

Option 2:

LH triggers ovulation in ovary.

Option 3:

LH and FSH decrease gradually during the follicular phase.

Option 4:

LH triggers secretion of androgens from the Leydig cells.

Correct Answer:

LH and FSH decrease gradually during the follicular phase.

Solution:

As discussed in

Ovulatory Phase -

The secretion of gonadotropins (LH and FSH) increases gradually during the follicular phase, and stimulates follicular development as well as secretion of estrogens by the growing follicles. Both LH and FSH attain a peak level in the middle of cycle (about 14th day).

- wherein

Rapid secretion of LH leading to its maximum level during the mid-cycle called LH surge induces rupture of Graafian follicle and thereby the release of ovum (ovulation).

Secretion of LH and FSH increases during follicular phase

Q. 57 Which of the following is a restriction endonuclease?

Option 1:

Hind II

Option 2:
Protease

Option 3:
DNase I

Option 4:
RNase

Correct Answer:
Hind II

Solution:

As we learnt in

Restriction Endonuclease -

These enzymes cleave DNA only within or near the specific base sequence. These sequences are called as recognition sites. They are of three types RE- I, RE-II and RE-III.

- wherein

1st Restriction enzyme (Hind II) was used in RDT.

Hind II are restriction endonuclease because they cleave DNA at specific sequence within DNA strand.

Q. 58 Microtubules are the constituents of:

Option 1:
Cilia, Flagella and Peroxisomes

Option 2:
Spindle fibres, Centrioles and Cilia

Option 3:
Centrioles, Spindle fibres and Chromatin

Option 4:
Centrosome, Nucleosome and Centrioles

Correct Answer:
Spindle fibres, Centrioles and Cilia

Solution:

Microtubules are unbranched hollow submicroscopic tubules of protein tubulin which develop on specific nucleating regions and can undergo quick growth or dissolution at their ends by assembly or disassembly of monomers. With the exception of Slime Moulds and Amoebae, microtubules occur widely in eukaryotic

cells. They are present in the cytoplasm as well as in specialized structures like centrioles, basal bodies, cilia or flagella, sensory hair, equatorial ring of thrombocytes, spindle fibres, chromosome fibres, etc.

Q. 59 Select the **correct** statement:

Option 1:

Gymnosperms are both homosporous and heterosporous

Option 2:

Salvinia, *Ginkgo* and *Pinus* all are gymnosperms

Option 3:

Sequoia is one of the tallest trees

Option 4:

The leaves of gymnosperms are not well adapted to extremes of climate

Correct Answer:

Sequoia is one of the tallest trees

Solution:

As we learnt in

Largest Gymnosperm -

Sequoia dendron

-

Q. 60 In higher vertebrates, the immune system can distinguish self-cells and non-self. If this property is lost due to genetic abnormality and it attacks self-cells, then it leads to:

Option 1:

Allergic response

Option 2:

Graft rejection

Option 3:

Auto-immune disease

Option 4:

Active immunity

Correct Answer:

Auto-immune disease

Solution:

As we learnt in

Auto-immune disease -

Sometimes, due to genetic and other unknown reasons, the body attack self-cells. This results in damage to the body and is called auto-immune disease.

- wherein

Rheumatoid arthritis which affects many people in our society is an auto-immune disease.

When the immune system cannot differentiate between self and non-self cells then the immune system attacks and destroys the self-cells and this is called auto-immunity.

Q. 61 In a testcross involving F₁ dihybrid flies, more parental-type offspring were produced than the recombinant-type offspring. This indicates:

Option 1:

The two genes are located on two different chromosomes.

Option 2:

Chromosomes failed to separate during meiosis.

Option 3:

The two genes are linked and present on the same chromosome.

Option 4:

Both of the characters are controlled by more than one gene.

Correct Answer:

The two genes are linked and present on the same chromosome.

Solution:

Linkage -

Morgan experimented and found that when the two genes in a hybrid cross situated on the same chromosome, the proportion of parental gene combination was much higher than the non-parental type.

Genetic linkage is the tendency of DNA sequences that are close together on a chromosome to be inherited together during the meiosis phase of sexual reproduction. Two genetic markers that are physically near to each other are unlikely to be separated onto different chromatids during the chromosomal crossover and are therefore said to be more linked than markers that are far apart. In

other words, the nearer two genes are on a chromosome, the lower the chance of recombination between them, and the more likely they are to be inherited together. Markers on different chromosomes are perfectly unlinked.

Hence, the correct option is 'the two genes are linked and present on the same chromosome'.

Q. 62 Which of the following statements is **not** correct?

Option 1:

Pollen germination and pollen tube growth are regulated by chemical components of pollen interacting with those of the pistil.

Option 2:

Some reptiles have also been reported as pollinators in some plant species.

Option 3:

Pollen grains of many species can germinate on the stigma of a flower, but only one pollen tube of the same species grows into the style.

Option 4:

Insects that consume pollen or nectar without bringing about pollination are called pollen/nectar robbers.

Correct Answer:

Pollen grains of many species can germinate on the stigma of a flower, but only one pollen tube of the same species grows into the style.

Solution:

The pollen tube is produced on the stigma by germination through one of the germ pores only when the correct pollen reaches the pistil. Pollen germination starts as soon as the pollen grain contacts the stigma. The pollen should therefore be applied to the pistil rather than the style.

Q. 63 Asthma may be attributed to:

Option 1:

bacterial infection of the lungs

Option 2:

allergic reaction of the mast cells in the lungs

Option 3:

inflammation of the trachea

Option 4:

accumulation of fluid in the lungs

Correct Answer:

allergic reaction of the mast cells in the lungs

Solution:

As we learnt in

DISORDERS OF RESPIRATORY SYSTEM -

Asthma

- wherein

Asthma is a difficulty in breathing causing wheezing due to inflammation of bronchi and bronchioles.

Asthma is one inflammation is bronchi and bronchioles due to a secretion of mast cells causes allergy.

Q. 64 In context of Amniocentesis, which of the following statement is **incorrect**?

Option 1:

It is usually done when a woman is between 14 - 16 weeks pregnant.

Option 2:

It is used for prenatal sex determination.

Option 3:

It can be used for detection of Down syndrome.

Option 4:

It can be used for detection of Cleft palate.

Correct Answer:

It can be used for detection of Cleft palate.

Solution:

As we learnt in

amniocentesis -

A foetal sex determination test based on the chromosomal pattern in the amniotic fluid surrounding the developing embryo. Amniocentesis can be used for the diagnosis of developmental abnormalities or infection of foetus and cleft palate is a developmental abnormality which may occur in the developing foetus and it can be detected by **sonography**, not by amniocentesis.

Q. 65 Specilised epidermal cells surrounding the guard cells are called:

Option 1:

Complementary cells

Option 2:

Subsidiary cells

Option 3:

Bulliform cells

Option 4:

Lenticels

Correct Answer:

Subsidiary cells

Solution:

Stomata:

- These are the tiny openings or pores in the epidermal system of plants, especially leaves.
- Stomata can also occur in stem.
- The stomata are surrounded by specialised epidermal cells called guard cells that regulate the opening and closing of stomata.
- Guard cells are generally bean-shaped in dicots and dumbbell shaped in monocots.
- Stomata regulate the gaseous exchange and transpiration.
- Some surrounding epidermal cells become specialised to form the **subsidiary cells**.
- The stomatal aperture, guard cells and subsidiary cells are called stomatal aperture.

Hence, the correct answer is subsidiary cells.

Q. 66 Which of the following is the most important cause of animals and plants being driven to extinction?

Option 1:

Over - exploitation

Option 2:

Alien species invasion

Option 3:

Habitat loss and fragmentation

Option 4:

Co-extinctions

Correct Answer:

Habitat loss and fragmentation

Solution:

As we learnt in

Habitat loss and fragmentation -

This is the most important cause of driving animals and plants to extinction. The most dramatic examples of habitat loss come from tropical rain forests. Once covering more than 14 per cent of the earth's land surface, these rain forests now cover no more than 6 per cent. They are being destroyed fast.

Q. 67 Analogous structures are a result of:

Option 1:

Divergent evolution

Option 2:

Convergent evolution

Option 3:

Shared ancestry

Option 4:

Stabilizing selection

Correct Answer:

Convergent evolution

Solution:

Analogous Organs -

The organs which have the same function and superficially alike but are quite different in fundamental structure and embryonic origin.

- wherein

Eg: insect and bird wings, Dragonfly, pterodactyl, Eagle, humerus, bat.

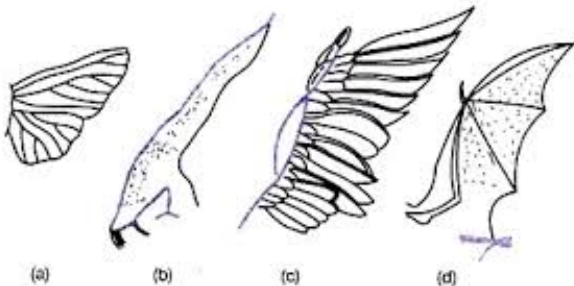

Fig. 7.4 Examples of analogous organs (a) Wing of insect (b) Wing of Pterodactyl (c) Wing of bird (d) Wing of bat

Analogous organs are those which are similar in function but do not have a common ancestor and thus they are a result of convergent evolution that different organisms shared a common environment. Convergent evolution describes the independent evolution of similar features in species of different lineages. The two species came to the same function, flying, but did so separately from each other.

Hence, the correct answer is 'convergent evolution'

Q. 68 Which of the following most appropriately describes haemophilia?

Option 1:

Recessive gene disorder

Option 2:

X-linked recessive gene disorder

Option 3:

Chromosomal disorder

Option 4:

Dominant gene disorder

Correct Answer:

X-linked recessive gene disorder

Solution:

Haemophilia is a sex-linked recessive disorder. It shows zig-zag pattern of inheritance. These kinds of defects occur more often in men than in women. A daughter gets an X chromosome from her mother and an X chromosome from her father.

Hence, the correct answer is 'X-linked recessive gene disorder'

Q. 69 Cotyledon of maize grain is called:

Option 1:
plumule

Option 2:
coleorhiza

Option 3:
coleoptile

Option 4:
scutellum

Correct Answer:
scutellum

Solution:

As we learnt in

Plant embryo structure -

The embryo consists of a cotyledon and an embryonal axis. The cotyledon is also called scutellum in cereals. The lower end of scutellum is called coleorhiza and upper part of axis is called the plumule which is covered by coleoptile.

-

Cereal cotyledons are called scutellum .

Q. 70 The term ecosystem was coined by:

Option 1:
E.P. Odum

Option 2:

A.G. Tansley

Option 3:

E. Haeckel

Option 4:

E. Warming

Correct Answer:

A.G. Tansley

Solution:

Ecosystem -

Ecology is basically concerned with four levels of biological organisation – organisms, populations, communities and biomes. Term ecology was coined by A.G. Tansley

Hence, the correct option is (b).

Q. 71 Which of the following features is not present in the phylum Arthropoda ?

Option 1:

Parapodia

Option 2:

Metameric segmentation

Option 3:

Chitinous exoskeleton

Option 4:

Jointed appendages

Correct Answer:

Parapodia

Solution:

As we have learned

Phylum Arthropoda -

Largest phylum of Animalia. They are triploblastic, metamerically segmented, bilaterally symmetrical and coelomate (filled with haemocoel)

- wherein

Eg. Apis, Bombyx, Anopheles.

Parapodia are found in annelids for locomotion and respiration

Q. 72 Which one of the following cell organelles is enclosed by a single membrane?

Option 1:

Mitochondria

Option 2:

Chloroplasts

Option 3:

Lysosomes

Option 4:

Nuclei

Correct Answer:

Lysosomes

Solution:

Lysosomes

- These are single membrane bound round or spherical organelles that function as digestive component and organelle-recycling facility of animal cells.
- They are not found in the plant cells.
- These were discovered by Christian de Duve in 1955.
- They contain hydrolytic enzymes that function at the acidic pH.
- Due to the presence of hydrolytic enzymes, they are also called suicidal bags.

-

Mitochondria, chloroplasts and nuclei are double-membrane bound cell-organelles. Lysosomes are are bound by a single membrane.

Q. 73 Which of the following is not a characteristic feature during mitosis in somatic cells?

Option 1:

Spindle fibres

Option 2:

Disappearance of nucleolus

Option 3:

Chromosome movement

Option 4:

Synapsis

Correct Answer:

Synapsis

Q. 74 A river with an inflow of domestic sewage rich in organic waste may result in :

Option 1:

Death of fish due to lack of oxygen

Option 2:

Drying of the river very soon due to algal bloom

Option 3:

Increased population of aquatic food web organisms

Option 4:

An increased production of fish due to biodegradable nutrients

Correct Answer:

Death of fish due to lack of oxygen

Solution:

As we have learnt in Water Pollution & Its Causes : Domestic Sewage & Algal Bloom -

Streams draining into the lake introduce nutrients such as nitrogen and phosphorus and domestic sewage, which encourage the growth of aquatic organisms. As the lakes fertility increases, algal bloom occurs. Algal bloom causes the degradation of water quality and fish mortality and dead remains begin to be deposited on the lake bottom. Over the year, the lake finally converted into the land.

Hence, the correct option is (a).

Q. 75 Which of the following is **not** required for any of the techniques of DNA fingerprinting available at present?

Option 1:

Polymerase chain reaction

Option 2:

Zinc finger analysis

Option 3:

Restriction enzymes

Option 4:

DNA-DNA hybridization

Correct Answer:

Zinc finger analysis

Solution:

As we learnt in

Steps of DNA fingerprinting -

- (a) Extraction of DNA from the sample cells.
- (b) Amplification of DNA by PCR
- (c) Restriction digestion of PCR Products
- (d) Separation on Agarose gel electrophoresis
- (e) Southern blotting
- (f) Hybridization using labelled VNTR probe
- (g) Detection by autoradiography

- wherein

This technique is widely used in forensic science for criminal cases

In DNA fingerprinting PCR Restriction enzymes and hybridisation techniques are used.

Q. 76 In meiosis crossing over is initiated at:

Option 1:
Pachytene

Option 2:
Leptotene

Option 3:
Zygotene

Option 4:
Diplotene

Correct Answer:
Pachytene

Solution:

As we learnt in

Pachytene -

The third stage of prophase I, bivalent chromosomes clearly appears as tetrads, crossing over between homologous chromosomes occur.

- wherein

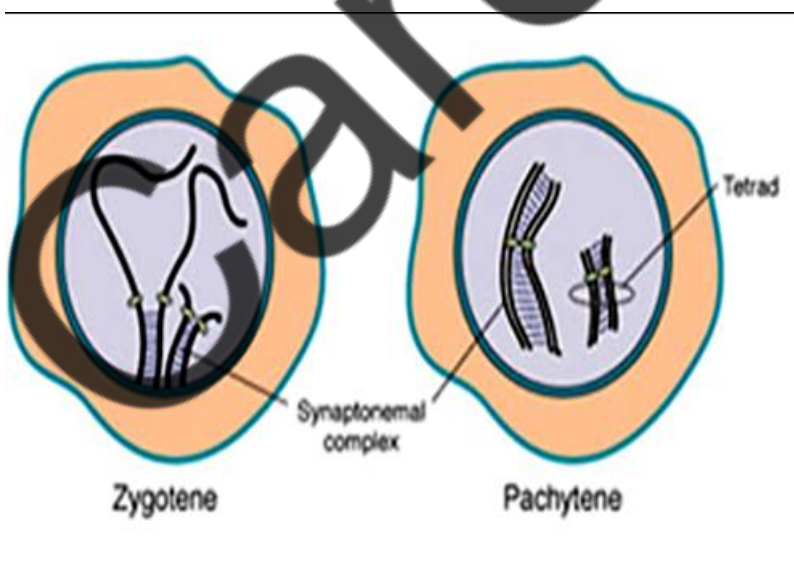

Crossing over takes place in pachytene.

Q. 77 Which one of the following statements is **wrong**?

Option 1:

Cyanobacteria are also called blue-green algae

Option 2:

Golden algae are also called desmids

Option 3:

Eubacteria are also called false bacteria

Option 4:

Phycomycetes are also called algal fungi

Correct Answer:

Eubacteria are also called false bacteria

Solution:

As we learnt in

Major Groups of Monera -

- Archaeobacteria (Ancient bacteria)
- Eubacteria (True Bacteria)

-

Q. 78 Blood pressure in the pulmonary artery is:

Option 1:

same as that in the aorta.

Option 2:

more than that in the carotid.

Option 3:

more than that in the pulmonary vein.

Option 4:

less than that in the venae cavae.

Correct Answer:

more than that in the pulmonary vein.

Solution:

As we learnt in

pulmonary artery and the aorta -

The openings of the right and the left ventricles into the pulmonary artery and the aorta respectively are provided with the semilunar valves.

- wherein

The valves in the heart allows the flow of blood only in one direction, i.e., from the atria to the ventricles and from the ventricles to the pulmonary artery or aorta. These valves prevent any backward flow.

The correct answer is (3), more than pulmonary vein pulmonary artery pressure is 3-20 mm Hg

Q. 79 Which of the following statements is **wrong** for viroids?

Option 1:

They lack a protein coat

Option 2:

They are smaller than viruses

Option 3:

They cause infections

Option 4:

Their RNA is of high molecular weight

Correct Answer:

Their RNA is of high molecular weight

Solution:

As we learnt in

Viroids -

Smallest self replicating particles having RNA without protein coat.

- wherein

Causes potato spindle tuber disease (PSTD).

Their RNA is of low molecular weight

Q. 80 Photosensitive compound in human eye is made up of :

Option 1:

Guanosine and Retinol

Option 2:

Opsin and Retinal

Option 3:

Opsin and Retinol

Option 4:

Transducin and Retinene

Correct Answer:

Opsin and Retinal

Solution:

As we learnt in

Visual cortex -

the photosensitive compounds (photopigments) in the human eyes is composed of opsin (a protein) and retinal (an aldehyde of vitamin A). Light induces dissociation of the retinal from opsin resulting in changes in the structure of the opsin. This causes membrane permeability changes.

- wherein

As a result, potential differences are generated in the photoreceptor cells. This produces a signal that generates action potentials in the ganglion cells through the bipolar cells. These action potentials (impulses) are transmitted by the optic nerves to the visual cortex area of the brain, where the neural impulses are analysed and the image formed on the retina is recognised based on earlier memory and experience.

Photosensitive compound are opsin and retinal.

Q. 81 One of the major components of cell wall of most fungi is

Option 1:

Chitin

Option 2:

Peptidoglycan

Option 3:

Cellulose

Option 4:

Hemicellulose

Correct Answer:

Chitin

Solution:

As we learnt in

Characteristics of fungi -

1. Eukaryotic and multicellular
2. Non -photosynthetic and heterotrophic
3. Cell wall composed of chitin and polysaccharides
4. Stored food - Glycogen
5. Fungal body made up of hyphae , which aggregate to form mycelia.
6. They are saprotrophic , parasitic or symbionts.

The fungal cell wall is predominately composed of carbohydrate polymers called chitin. Chitin provides mechanical strength to the cell wall.

Q. 82 Following are the two statements regarding the origin of life :

- a. The earliest organisms that appeared on the earth were non-green and presumably anaerobes.
- b. The first autotrophic organisms were the chemoautotrophs that never released oxygen.

Of the above statements which one of the following options is correct?

Option 1:

(a) is correct but (b) is false.

Option 2:

(b) is correct but (a) is false.

Option 3:

Both (a) and (b) are correct.

Option 4:

Both (a) and (b) are false.

Correct Answer:

Both (a) and (b) are correct.

Solution:

According to the abiogenesis hypothesis, both of the statements about the origin of life are true. It is believed that non-living substances like simple organic compounds are where life first began.

Q. 83 Chrysophytes, Euglenoids, Dinoflagellates and Slime moulds are included in the kingdom

Option 1:

Monera

Option 2:

Protista

Option 3:

Fungi

Option 4:

Animalia

Correct Answer:

Protista

Solution:

As we learnt in

Photosynthetic protists -

Three type

- Diatoms (Chrysophytes)
- Dinoflagellates
- Euglenoids

Q. 84 Tricarpellary, syncarpous gynoecium is found in flowers of:

Option 1:

Liliaceae

Option 2:
Solanaceae

Option 3:
Fabaceae

Option 4:
Poaceae

Correct Answer:
Liliaceae

Solution:

As we have learnt in:

Description of Some Important Families: Liliaceae

Commonly called the 'Lily family' is a characteristic representative of monocotyledonous plants. It is distributed world wide.

Vegetative characters:

- Stem: Perennial herbs with underground bulbs/corms/ rhizomes
- Leaves: mostly basal, alternate, linear, exstipulate with parallel venation

Floral characters

- Inflorescence: solitary / cymose; often umbellate clusters
- Flower: bisexual; actinomorphic
- Perianth tepal six (3+3), often united into tube; valvate aestivation
- Androecium: stamen six, 3+3, epitepalous
- Gynoecium: tricarpeal, syncarpous, ovary superior, trilocular with many ovules; axile placentation
- Fruit: capsule, rarely berry
- Seed: endospermous

Hence, Liliaceae has tricarpeal, syncarpous, trilocular gynoecium.

Q. 85 A complex of ribosomes attached to a single strand of RNA is known as :

Option 1:
Polysome

Option 2:
Polymer

Option 3:
Polypeptide

Option 4:
Okazaki fragment

Correct Answer:
Polysome

Solution:
As we learnt in

Functions of types of RNA -

The mRNA provides the template for tRNA to bring amino acids and reads genetic code and rRNAs plays structural and catalytic during translation. A chain of ribosomes attaches to a single mRNA is called polysome or polyribosomes. The ribosomes in a polysome are connected by a single molecule of mRNA that is being translated simultaneously by many closely spaced ribosomes.

Q. 86 In the stomach, gastric acid is secreted by the :

Option 1:
gastrin secreting cells

Option 2:
parietal cells

Option 3:
peptic cells

Option 4:
acidic cells

Correct Answer:
parietal cells

Solution:

- The cells of the gastric glands are as follows:
- › The cells at the base of these pits are **chief cells or zymogenic cell or peptic cell** that are responsible for the production of pepsinogen, an inactive precursor of pepsin, which degrades proteins.
- › Further up the pits, **parietal cells or oxyntic cells** produce gastric acid and a vital substance, intrinsic factor. The gastric acid kills most of the bacteria in food, stimulates hunger, and activates pepsinogen into pepsin. It denatures the complex protein molecule as a precursor to protein digestion through enzyme action in the stomach and small intestines.
- › Near the top of the pits, closest to the contents of the stomach, there are mucus-producing cells called **goblet cells** that help protect the stomach from self-digestion.
- › The **G-cells or entero-enteric cells** secrete gastrin hormone.
- › The **argentaffin cells** secrete serotonin, somatostatin and histamine.

Hence, the correct option is parietal cells.

Q. 87 Identify the correct statement on 'inhibin':

Option 1:

Inhibits the secretion of LH, FSH and Prolactin.

Option 2:

Is produced by granulosa cells in ovary and inhibits the secretion of FSH.

Option 3:

Is produced by granulosa cells in ovary and inhibits the secretion of LH.

Option 4:

Is produced by nurse cells in testes and inhibits the secretion of LH.

Correct Answer:

Is produced by granulosa cells in ovary and inhibits the secretion of FSH.

Solution:

Inhibin is a protein secreted by granulosa (female) and Sertoli (male) cells in response to FSH, and its major action is the negative feedback control of pituitary FSH secretion by the pituitary gland.

Hence, the correct answer is 'Is produced by granulosa cells in ovary and inhibits the secretion of FSH'

Q. 88 The standard petal of a papilionaceous corolla is also called:

Option 1:

Carina

Option 2:

Pappus

Option 3:

Vexillum

Option 4:

Corona

Correct Answer:

Vexillum

Solution:

Papilionaceous flowers are flowers with the characteristic irregular and butterfly-like corolla. The flowers have a bilateral symmetry with the corolla consisting of five petals. A single, large, upper petal is known as the banner (also vexillum or standard petal).

Q. 89 In bryophytes and pteridophytes, transport of male gametes requires

Option 1:
Wind

Option 2:
Insects

Option 3:
Birds

Option 4:
Water

Correct Answer:
Water

Solution:

As we learnt in

Amphibians of plant kingdom -

Bryophytes are called so because they depend on external water for fertilization and completion of their life cycle.

-

Q. 90 Proximal end of the filament of stamen is attached to the:

Option 1:
Anther

Option 2:
Connective

Option 3:
Placenta

Option 4:
Thalamus or petal

Correct Answer:
Thalamus or petal

Solution:

As we learnt in the structure of Stamen -

A typical stamen has two parts - the long and slender stalk called the filament, and the terminal generally bilobed structure called the anther. The proximal end of the filament is attached to the thalamus or the petal of the flower.

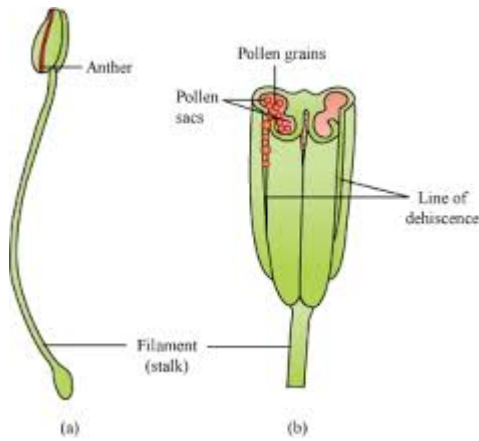

Proximal end of the filament of stamen is attached to Thalamus or petal.

Hence, the correct answer is option d.

Careers360

NEET 2016 Phase 2

Physics

- Q. 1** An infinitely long straight conductor carries a current of 5A as shown. An electron is moving with a speed of 10^5 m/s parallel to the conductor. The perpendicular distance between the electron and the conductor is 20 cm at an instant. Calculate the magnitude of the force experienced by the electron at that instant.

Electron $v = 10^5$ m/s

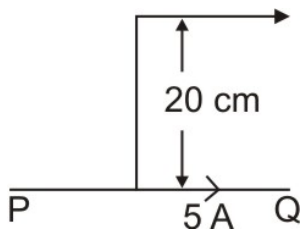

Option 1:

$$4 \times 10^{-20} \text{ N}$$

Option 2:

$$8\pi \times 10^{-20} \text{ N}$$

Option 3:

$$4\pi \times 10^{-20} \text{ N}$$

Option 4:

$$8 \times 10^{-20} \text{ N}$$

Correct Answer:

$$8 \times 10^{-20} \text{ N}$$

Solution:

$$i = 5 \text{ A}$$

$$e = 1.6 \times 10^{-19} \text{ C} \quad v = 10^5 \text{ m/s}$$

$$F = qvB \sin \theta = qvB \sin 90^\circ$$

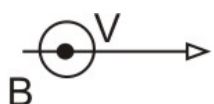

$$B = \frac{\mu_0 I}{2\pi r}$$

$$F = 1.6 \times 10^{-19} \times 10^5 \times \frac{2 \times 10^{-7} \times 5}{2 \times 10^{-1}}$$

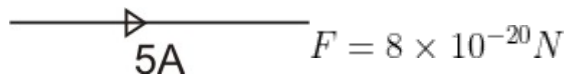

Q. 2 A dipole is placed in an electric field as shown. In which direction will it move?

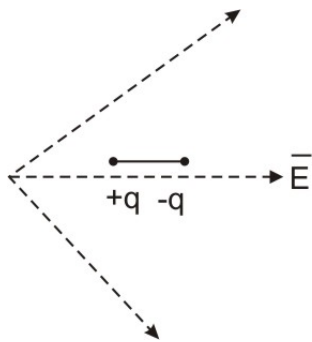

Option 1:

towards the left as its potential energy will increase.

Option 2:

towards the right as its potential energy will decrease.

Option 3:

towards the left as its potential energy will decrease.

Option 4:

towards the right as its potential energy will increase.

Correct Answer:

towards the right as its potential energy will decrease.

Solution:

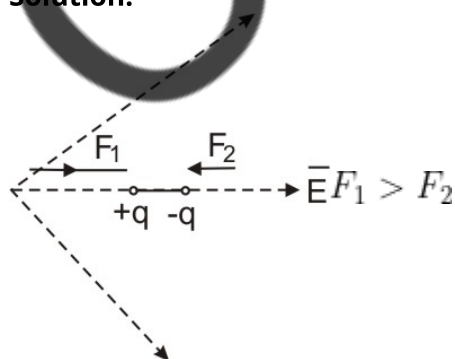

F_{net} (towards right)

electric field intensity is more at $+q$ as field lines are closer

$$V_2 - V_1 = -PE_2 \cos \theta_2 - (-PE_1 \cos \theta_1)$$

$$\theta_1 = \theta_2 = 180^\circ (\text{along given line})$$

$$E_2 < E_1 (\text{as it move towards right})$$

$$= (+PE_2) - (+PE_1)$$

$$\therefore \Delta U \Rightarrow \text{Decrease}$$

Q. 3 An inductor of inductance L, a capacitor of capacitance C and a resistor of resistance 'R' are connected in series to an ac source of potential difference 'V' volts as shown in figure.

Potential difference across, C and R is 40 V, 10V and 40V, respectively. The amplitude of current flowing through LCR series circuit is $10\sqrt{2}A$. The impedance of the circuit is:

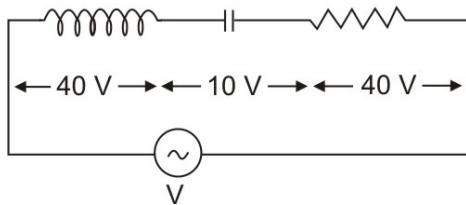

Option 1:

$$4\sqrt{2}\Omega$$

Option 2:

$$\frac{5}{\sqrt{2}}\Omega$$

Option 3:

$$4\Omega$$

Option 4:

$$5\Omega$$

Correct Answer:

$$5\Omega$$

Solution:

$$V_{rms} = \sqrt{V_R^2 + (V_L - V_C)^2}$$

$$= \sqrt{(40)^2 + (30)^2} = 50$$

$$V_{peak} = (V_{rms}) \times \sqrt{2}$$

$$= 50\sqrt{2}$$

$$Z = \frac{V_{peak}}{I_{peak}} = \frac{50\sqrt{2}}{10\sqrt{2}} = 5\Omega$$

Q. 4 For a plane electromagnetic wave propagating in x-direction, which one of the following combination given the correct possible direction for electric field (E) and magnetic field (B) respectively?

Option 1:

$$\hat{j} + \hat{k}, \hat{j} + \hat{k}$$

Option 2:

$$-\hat{j} + \hat{k}, -\hat{j} - \hat{k}$$

Option 3:

$$\hat{j} + \hat{k}, -\hat{j} + \hat{k}$$

Option 4:

$$-\hat{j} + \hat{k}, -\hat{j} + \hat{k}$$

Correct Answer:

$$-\hat{j} + \hat{k}, -\hat{j} - \hat{k}$$

Solution:

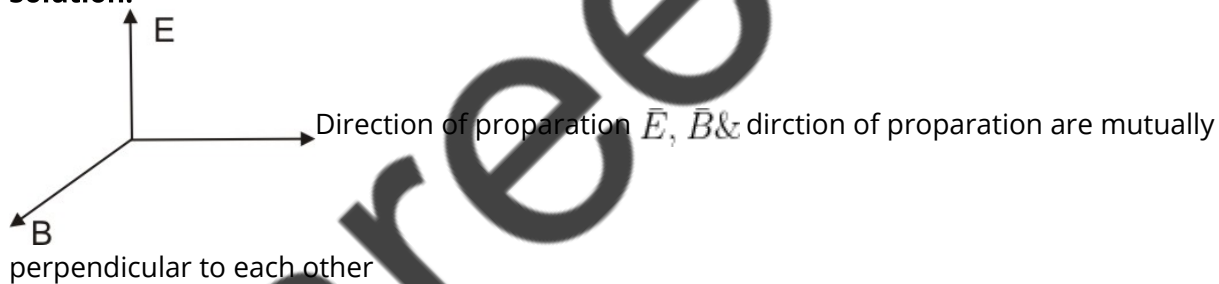

$$\vec{E} \cdot \vec{B} = EB \cos 90^\circ = 0$$

Q. 5 A lens of large focal length and large aperture is best suited as an objective of an astronomical telescope since:

Option 1:

A large aperture contributes to the quality and visibility of image.

Option 2:

A large area of the objective ensures better light gathering power.

Option 3:

a large aperture provides a better resolution

Option 4:

all of the above

Correct Answer:

all of the above

Solution:

$$\text{Magnification of telescope} = \frac{f_o}{\mu_o} = f_o \left[\frac{1}{f_e} + \frac{1}{V_e} \right]$$

Large focal length → better Magnification

Large aperture → better light gathering power

Hence, the answer is the option (4).

Q. 6

Column - I gives certain physical terms associated with the flow of current through a metallic conductor.

Column - II gives some mathematical relations involving electrical quantities.

Match Column - I and Column - II with appropriate relation.

	Column I		Column II
(A)	Drift Velocity	(P)	$\frac{m}{ne^2\rho}$
(B)	Electrical Resistivity	(Q)	nev_d
(C)	Relaxation Period	(R)	$\frac{eE}{m}\tau$
(D)	Current Density	(S)	$\frac{E}{J}$

Option 1:

(A)-(R), (B)-(S), (C)-(P), (D)-(Q)

Option 2:

(A)-(R), (B)-(S), (C)-(Q), (D)-(P)

Option 3:

(A)-(R), (B)-(P), (C)-(S), (D)-(Q)

Option 4:

(A)-(R), (B)-(Q), (C)-(S), (D)-(P)

Correct Answer:

(A)-(R), (B)-(S), (C)-(P), (D)-(Q)

Solution:

$$\frac{E}{J} = \frac{1}{\sigma} = \rho = \text{Electrical Resistivity}$$

$$\text{Drift Velocity} = V_2 = \frac{eE\tau}{m}$$

$$\text{Relaxation Period} = \tau = \frac{m}{ne^2\rho}$$

$$\text{Current density} = J = neV_2$$

$$A - R, B - S, C - P, D - Q$$

Hence, the answer is the option (1).

Q. 7 An electromagnetic wave of wavelength ' λ ' is incident on a photosensitive surface of negligible work function. If 'm' mass is of photoelectron emitted from the surface has de-Broglie wavelength λ_d , then:

Option 1:

$$\lambda = \left(\frac{2m}{hc}\right) \lambda_d^2$$

Option 2:

$$\lambda_d = \left(\frac{2mc}{h}\right) \lambda^2$$

Option 3:

$$\lambda = \left(\frac{2mc}{h}\right) \lambda_d^2$$

Option 4:

$$\lambda = \left(\frac{2h}{mc}\right) \lambda_d^2$$

Correct Answer:

$$\lambda = \left(\frac{2mc}{h}\right) \lambda_d^2$$

Solution:

Work Function \rightarrow negligible

$$\phi \simeq 0$$

$$\frac{hc}{\lambda} = \phi + kE_{max}$$

$$\frac{hc}{\lambda} = 0 + \frac{p^2}{2m} = \frac{(h/\lambda_d)^2}{2m}$$

$$\frac{kc}{\lambda} = \frac{h}{\lambda_d^2 \times 2m}$$

$$\left(\frac{2mc}{h}\right) \lambda_d^2 = \lambda$$

Hence, the answer is the option (3).

-
- Q. 8** A particle is released from height S from the surface of the earth. At a certain height its kinetic energy is three times its potential energy. The height from the surface of the earth and the speed of the earth and the speed of the particle at that instant are respectively:

Option 1:

$$\frac{S}{4}, \frac{\sqrt{3gS}}{2}$$

Option 2:

$$\frac{S}{4}, \frac{\sqrt{3gS}}{2}$$

Option 3:

$$\frac{S}{2}, \frac{\sqrt{3gS}}{2}$$

Option 4:

$$\frac{S}{4}, \sqrt{\frac{3gS}{2}}$$

Correct Answer:

$$\frac{S}{4}, \sqrt{\frac{3gS}{2}}$$

Solution:

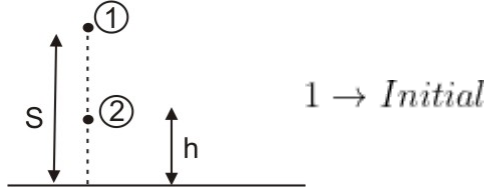

2 → Final

$$TE_1 = TE_2$$

$$mgs + 0 = (mgh) + KE$$

$$(KE) = 3(mgh) \text{ (Given)}$$

$$mgs = 4mgh$$

$$h = \frac{s}{4}$$

$$3mgh = \frac{1}{2}mv^2$$

$$v = \sqrt{2gh \times 3} = \sqrt{2g \frac{s}{4} \times 3} = \sqrt{\frac{gs}{2} \times 3}$$

$$v = \sqrt{\frac{3gS}{2}}$$

Q.9 A screw gauge gives the following reading when used to measure the diameter of a wire

Main scale reading : 0 mm

Circular scale reading : 52 divisions

Given that 1 mm on main scale corresponds to 100 divisions on the circular scale. The diameter of the wire from the above data is:

Option 1:

0.52 cm

Option 2:

0.026 cm

Option 3:

0.26 cm

Option 4:

0.052 cm

Correct Answer:

0.052 cm

Solution:

$$1 \text{ MSD} = 100 \text{ CSD} = 1 \text{ mm}$$

$$\text{CSR} = 52 \text{ Division} = 0.52 \text{ mm}$$

$$\text{Reading} = \text{MSR} + \text{CSR}$$

$$= 0 + 0.52 \text{ mm}$$

$$= 0.052 \text{ cm}$$

Q. 10 A thick current carrying cable of radius 'R' carries current ' I ' uniformly distributed across its cross-section. The variation of magnetic field $B(r)$ due to the cable with the distance ' r ' from the axis of the cable is represented by:

Option 1:

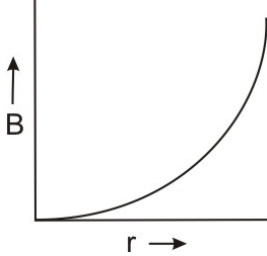

Option 2:

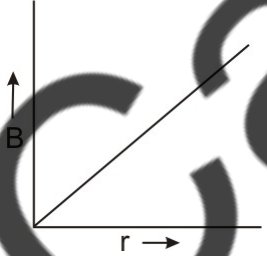

Option 3:

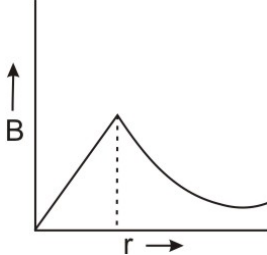

Option 4:

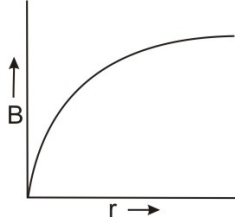

Correct Answer:

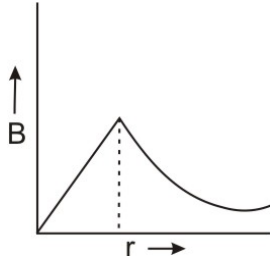

Solution:

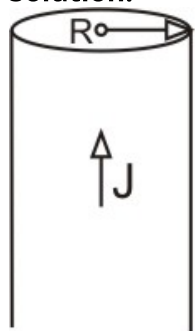

$$B = \frac{\mu_0 I r}{2\pi R^2} \quad (r < R)$$

$$B = \frac{\mu_0 I}{2\pi r} \quad (r > R)$$

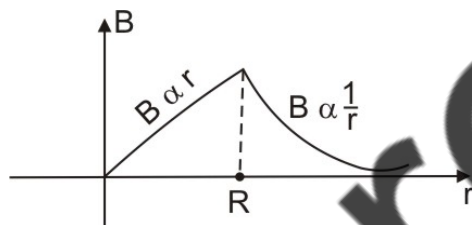

Q. 11 Two charged spherical conductors of radius R_1 and R_2 are connected by a wire. Then the ratio of surface charge densities of the spheres (σ_1/σ_2) is :

Option 1:

$$\frac{R_1}{R_2}$$

Option 2:

$$\frac{R_2}{R_1}$$

Option 3:

$$\sqrt{\left(\frac{R_1}{R_2}\right)}$$

Option 4:

$$\frac{R_1^2}{R_2^2}$$

Correct Answer:

$$\frac{R_2}{R_1}$$

Solution:

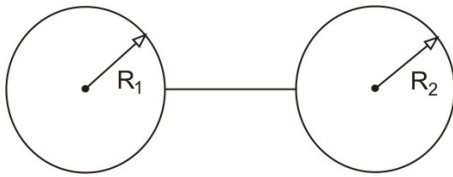

$$V_1 = V_2$$

$$\frac{kQ_1}{R_1} = \frac{kQ_2}{R_2}$$

$$\frac{Q_1}{Q_2} = \frac{R_1}{R_2}$$

$$\frac{\sigma_1}{\sigma_2} = \frac{Q_1/4\pi R_1^2}{Q_2/4\pi R_2^2} = \frac{R_2^2}{R_1^2} \times \frac{R_1}{R_2}$$

$$\frac{\sigma_1}{\sigma_2} = \frac{R_2}{R_1}$$

Q. 12 The number of photons per second on average emitted by the source of monochromatic light of wavelength 600 nm, when it delivers the power of 3.3×10^{-3} watt will be :
($h = 6.6 \times 10^{-34}$ Js)

Option 1:

$$10^{18}$$

Option 2:

$$10^{17}$$

Option 3:

$$10^{16}$$

Option 4:

$$10^{15}$$

Correct Answer:

$$10^{16}$$

Solution:

$$\lambda = 600nm$$

$$P = 3.3 \times 10^{-3}w$$

$$h = 6.6 \times 10^{-34}Js$$

$$\text{No. of photons per second} = \frac{P}{\frac{hc}{\lambda}} = \frac{3.3 \times 10^{-3}}{\frac{6.6 \times 10^{-34} \times 3 \times 10^8}{6 \times 10^{-7}}} = 1 \times 10^{16}$$

Hence, the answer is the option (3).

Q. 13 A cup of coffee cools from $90^\circ C$ to $80^\circ C$ in t minutes, when the room temperature is $20^\circ C$. The time taken by a similar cup of coffee to cool from $80^\circ C$ to $60^\circ C$ at a room temperature same at $20^\circ C$ is:

Option 1:

$$\frac{13}{10}t$$

Option 2:

$$\frac{13}{5}t$$

Option 3:

$$\frac{10}{13}t$$

Option 4:

$$\frac{5}{13}t$$

Correct Answer:

$$\frac{13}{5}t$$

Solution:

$$\frac{\Delta T}{\Delta t} = -k(T_{ang} - T_0)$$

$$\frac{\frac{90-80}{t}}{\frac{(80-60)}{\Delta t}} = \frac{\left(\frac{90+80}{2} - 20\right)}{\left(\frac{80+60}{2} - 20\right)}$$

$$\frac{\frac{10}{t}}{\frac{20}{\Delta t}} = \frac{65}{50} = \frac{13}{10}$$

$$\frac{\Delta t}{2t} = \frac{13}{10}$$

$$\Delta t = \frac{13t}{5}$$

Q. 14 The equivalent capacitance of the combination shown in the figure is:

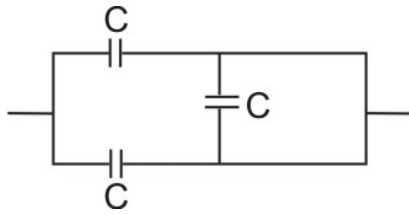

Option 1:

$$3C$$

Option 2:

$$2C$$

Option 3:

$$C/2$$

Option 4:

$$3C/2$$

Correct Answer:

$$C/2$$

Solution:

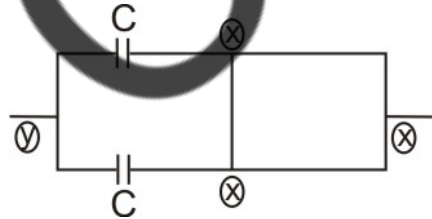

Capacitor is short circuited

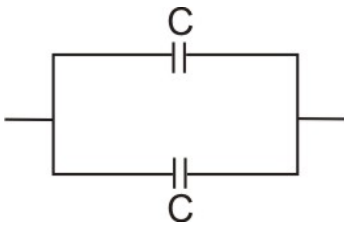

$$C_{eq} = 2C$$

Q. 15 The effective resistance of a parallel connection consists of four wires of equal length, equal area of cross-section, and the same material 0.25Ω . What will be the effective resistance if they are connected in series?

Option 1:
 0.25Ω

Option 2:
 0.5Ω

Option 3:
 1Ω

Option 4:
 4Ω

Correct Answer:
 4Ω

Solution:

Four wires each of resistance for R parallel connection

$$R_{eq} = \frac{R}{4} = 0.25$$

$$\therefore R = 1$$

For series connection

$$R_{eq} = 4R = 4(1) = 4\Omega$$

Hence, the answer is the option (4).

Q. 16 Find the value of the angle of emergence from the prism. Refractive index of the glass is $\sqrt{3}$.

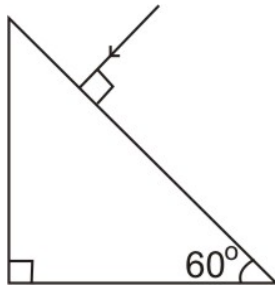

Option 1:

60°

Option 2:

30°

Option 3:

45°

Option 4:

90°

Correct Answer:

60°

Solution:

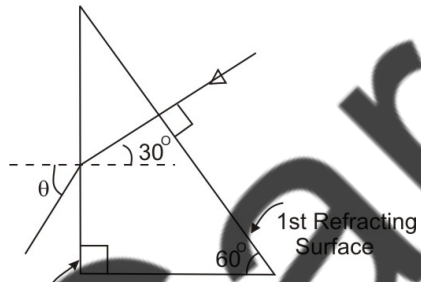

2nd Refracting Surface

$$\mu_1 \sin 30^\circ = \mu_2 \sin \theta$$

$$\sqrt{3} \times \frac{1}{2} = 1 \sin \theta$$

$$\theta = 60^\circ$$

$\theta = \text{Angle of emergence} = 60^\circ$

Q. 17 A small block slides down on a smooth inclined plane, starting from rest at time $t=0$. Let S_n be the distance travelled by the block in the interval $t=n-1$ to $t=n$.

Then, the ratio $\frac{S_n}{S_{n+1}}$ is:

Option 1:
$$\frac{2n-1}{2n}$$

Option 2:
$$\frac{2n-1}{2n+1}$$

Option 3:
$$\frac{2n+1}{2n-1}$$

Option 4:
$$\frac{2n}{2n-1}$$

Correct Answer:
$$\frac{2n-1}{2n+1}$$

Solution:

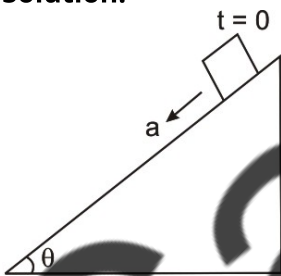

From $t = 0$ to $t = n - 1$

$$S_1 = 0 + \frac{1}{2}a(n-1)^2$$

From $t = 0$ to $t = n$

$$S_2 = 0 + \frac{1}{2}a(n)^2$$

From $t = 0$ to $t = n + 1$

$$S_3 = 0 + \frac{1}{2}a(n+1)^2$$

$$S_n = S_2 - S_1$$

$$S_n = \frac{1}{2}a [n^2 - (n^2 - 2n + 1)]$$

$$S_{n+1} = S_3 - S_2 = \frac{1}{2}a [n^2 + 2n + 1 - n^2]$$

$$\frac{S_n}{S_{n+1}} = \frac{(2n-1)}{(2n+1)}$$

Q. 18 The escape velocity from the Earth's surface is V . The escape velocity from the surface of another planet having a radius, four times that of Earth and the same mass density is :

Option 1:

V

Option 2:

$2V$

Option 3:

$3V$

Option 4:

$4V$

Correct Answer:

$4V$

Solution:

$$\text{Escape velocity from the Earth's surface} = V = \sqrt{\frac{2GM}{R}}$$

$$\text{Escape velocity from a planet} = V' = \sqrt{\frac{2GM'}{R'}}$$

$$R' = 4R$$

$$M = 3 \times \frac{4}{3}\pi R^3$$

$$M' = 3 \times \frac{4}{3}\pi (R')^3 = 64M$$

$$\frac{V}{V'} = \sqrt{\frac{M}{M'} \times \frac{R'}{R}} = \sqrt{\frac{1}{64} \times \frac{4R}{R}}$$

$$\frac{V}{V'} = \frac{1}{4}$$

$$V' = 4V$$

Hence, the answer is the option (4).

Q. 19 The half - life of a radioactive nuclide is 100 hours. The fraction of original activity that will remain after 150 hours would be:

Option 1:

$$\frac{1}{2}$$

Option 2:

$$\frac{1}{2\sqrt{2}}$$

Option 3:

$$\frac{2}{3}$$

Option 4:

$$\frac{2}{3\sqrt{2}}$$

Correct Answer:

$$\frac{1}{2\sqrt{2}}$$

Solution:

$$T_{\frac{1}{2}} = 100 \text{ hours}$$

$$\frac{N_t}{N_o} = 2^{-t/T_{\frac{1}{2}}} = 2^{-150/100}$$

$$\frac{N_t}{N_o} = 2^{-3/2} = \frac{1}{2\sqrt{2}}$$

Q. 20 In a potentiometer circuit a cell of EMF 1.5 V gives balance point at 36 cm length of wire. If another cell of EMF 2.5 V replace the first cell, then at what length of the wire, the balance point occurs?

Option 1:

60 cm

Option 2:

21.6 cm

Option 3:

64 cm

Option 4:

62 cm

Correct Answer:

60 cm

Solution:

$$\frac{E_1}{E_2} = \frac{l_1}{l_2}$$

$$\frac{1.5}{2.5} = \frac{36}{l_2}$$

$$\frac{3}{5} = \frac{36}{l_2}$$

$$l_2 = 60 \text{ cm}$$

Q. 21 Water falls from a height of 60 m at the rate of 15 kg/s to operate a turbine. The losses due to frictional force are 10% of the input energy. How much power is generated by the turbine? ($g = 10 \text{ m/s}^2$)

Option 1:

10.2 kW

Option 2:

8.1 kW

Option 3:

12.3 kW

Option 4:

7.0 kW

Correct Answer:

8.1 kW

Solution:

$$\frac{dm}{dt} = 15 \frac{\text{kg}}{\text{s}}$$

$$\frac{P_{out}}{P_{input}} = \eta = \frac{90}{100}$$

$$P_{output} = \eta P_{input}$$
$$= 0.9 \times \left(\frac{dmgh}{dt} \right)$$

$$= 0.9 \times 15 \times 10 \times 60$$

$$P_{output} = 8.1kW$$

Hence, the answer is the option (2).

Q. 22 The electron concentration in an n-type semiconductor is the same as the hole concentration in a p-type semiconductor. An external field (electric) is applied across each of them. Compare the currents in them.

Option 1:

Current in n-type = current in p-type

Option 2:

Current in p-type > current in n-type

Option 3:

Current in n-type < current in p-type

Option 4:

No current will flow in p-type, current will only flow in n-type

Correct Answer:

Current in n-type = current in p-type

Solution:

In both n-type and p-type semiconductors, electric current is due to a minority charge carrier when an electric field is applied across each of them. (as there is no diffusion)

Current in n-type = current in p-type

Hence, the answer is the option (1).

Q. 23 Match Column-I and Column-II and Choose the correct match from the given choice

Column-I	Column-II
(A) Root Mean square speed of gas molecules	(P) $\frac{1}{3}nm$
(B) Pressure exerted by ideal gas	(Q) $\sqrt{\frac{3RT}{M}}$
(C) Average kinetic energy of a molecules	(R) $\frac{5}{2}RT$
(D) Total internal energy of 1 mole of a diatomic gas	(S) $\frac{3}{2}K_B T$

Option 1:

(A)-(R),(B)-(P),(C)-(S),(D)-(Q)

Option 2:

(A)-(Q),(B)-(R),(C)-(S),(D)-(P)

Option 3:

(A)-(Q),(B)-(P),(C)-(S),(D)-(R)

Option 4:

(A)-(R),(B)-(Q),(C)-(P),(D)-(S)

Correct Answer:

(A)-(Q),(B)-(P),(C)-(S),(D)-(R)

Solution:

Root Mean square speed of gas molecules = $V_{rms} = \sqrt{\frac{3RT}{M}}$

The pressure exerted by the ideal gas = $P = \frac{1}{3}nm(\bar{V})^2$

Average KE of a molecules = $\frac{3}{2}K_B T$

Total internal energy of 1 mole of a diatomic gas = $\frac{5}{2}RT$

Hence, the answer is the option (3).

Q. 24 A spring is stretched by 5 cm by a force of 10 N. The period of the oscillations when a mass of 2 kg is suspended by it is :

Option 1:

0.0628 s

Option 2:

6.28 s

Option 3:

3.14 s

Option 4:

0.628 s

Correct Answer:

0.628 s

Solution:

$$x = 5\text{cm}$$

$$F = 10\text{N}$$

$$K = F/x$$

$$T = 2\pi\sqrt{\frac{m}{k}} = 2\pi\sqrt{\frac{2}{200}}$$

$$T = \frac{\pi}{s} = 0.628\text{s}$$

Hence, the answer is the option (4).

Q. 25 The velocity of a small ball of mass M and density d , when dropped in a container filled with glycerine becomes constant after some time. If the density of glycerine is $\frac{d}{2}$, then the viscous force acting on the ball will be:

Option 1:

$$\frac{Mg}{2}$$

Option 2:

$$Mg$$

Option 3:

$$\frac{3}{2}Mg$$

Option 4:

$$2Mg$$

Correct Answer:

$$\frac{Mg}{2}$$

Solution:

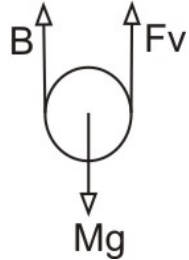

$$Mg = dvv$$

$$B = \frac{d}{2} \times vv = \frac{Mg}{2}$$

$F_v \rightarrow$ viscous force

$$B + F_v = Mg$$

$$F_v = Mg - \frac{mg}{2}$$

$$F_v = \frac{mg}{2}$$

Q. 26 A body is executing simple harmonic motion with frequency 'n'. The frequency of its potential energy is:

Option 1:

$$n$$

Option 2:

$$2n$$

Option 3:

$$3n$$

Option 4:

$$4n$$

Correct Answer:

$$2n$$

Solution:

$$x = A \sin \omega t$$

$$PE = \frac{1}{2} m \omega^2 x^2 = \frac{1}{2} m \omega^2 A^2 \left[\frac{1 - \cos 2\omega t}{2} \right]$$

$$pE = \frac{1}{4} m \omega^2 A^2 [1 - \cos(2\omega t)]$$

$$\text{As, } \omega = 2\pi n$$

$$PE = \frac{1}{4} m \omega^2 A^2 [1 - \cos(4\pi n t)]$$

The angular frequency of PE is 2ω

\therefore Frequency = $2n$

Hence, the answer is the option (2).

Q. 27 A nucleus with mass number 240 breaks into two fragments each of mass number 120, the binding energy per nucleon of unfragmented nuclei is 7.6 MeV while that of fragments is 8.5 MeV. The total gain the binding energy in the process is:

Option 1:
0.9 MeV

Option 2:
9.4 MeV

Option 3:
804 MeV

Option 4:
216 MeV

Correct Answer:
216 MeV

Solution:

BE per nucleon of unfragmented nuclei = 7.6 MeV

BE per nucleon of fragmented nuclei = 8.5 MeV

An increase in BE per nucleon is 0.9 MeV

For 240 nucleons, total BE is $0.9 \times 240 = 216 \text{ MeV}$

Hence, the answer is the option (4).

Q. 28 A parallel plate capacitor has a uniform electric field \vec{E} in the space between the plates. If the distance between the plates is 'd' and the area of each plate 'A', then the energy stored in the capacitor is :(ϵ_0 =permittivity of free space)

Option 1:

$$\frac{1}{2}\epsilon_0 E^2$$

Option 2:

$$\epsilon_0 EAd$$

Option 3:

$$\frac{1}{2}\epsilon_0 E^2 Ad$$

Option 4:

$$\frac{E^2 Ad}{\epsilon_0}$$

Correct Answer:

$$\frac{1}{2}\epsilon_0 E^2 Ad$$

Solution:

$$V = Ed, \quad C = \frac{A\epsilon_0}{d}$$

$$\text{Energy stored in the capacitor} = \frac{1}{2}CV^2 = \frac{1}{2} \times \frac{A\epsilon_0}{d} \times E^2 d^2 = \frac{1}{2}\epsilon_0 E^2 Ad$$

Hence, the answer is the option (3).

Q. 29 Polar molecules are the molecules:

Option 1:

having zero dipole moment .

Option 2:

acquire a dipole moment only in the presence of electric field due to displacement of charges.

Option 3:

acquire a dipole moment only when magnetic field is absent.

Option 4:

Having a permanent electric dipole moment .

Correct Answer:

Having a permanent electric dipole moment .

Solution:

Polar molecules have permanent electric dipole moments.

Hence, the answer is the option (4).

Q. 30 A radioactive nucleus A_ZX undergoes spontaneous decay in the sequence ${}^A_ZX \rightarrow Z - 1B \rightarrow Z - 3 \rightarrow C \rightarrow Z - 2D$, where Z is the atomic number of element X. The possible decay particles in the sequence are

Option 1:

α, β^-, β^+

Option 2:

α, β^+, β^-

Option 3:

β^+, α, β^-

Option 4:

β^-, α, β^+

Correct Answer:

β^+, α, β^-

Solution:

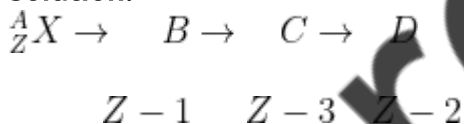

With β^+ decay, Z decrease by 1 with α -decay, Z decrease by 2 (from z-1 to z-3)

with β^- decay, Z increase by 1 (from z-3 to z-2)

decay particles in the sequence are β^+, α, β^-

Q. 31 Consider the following statements (A) and (B) and identify the correct answer:

(A) A zener diode is connected in reverse bias when used as a voltage regulator

(B) The potential barrier of the p-n junction lies between 0.1 V to 0.3 V

Option 1:

(A) and (B) are correct

Option 2:

(A) and (B) both are incorrect

Option 3:

(A) is correct and (B) is incorrect .

Option 4:

(A) is incorrect but (B) is correct.

Correct Answer:

(A) is correct and (B) is incorrect .

Solution:

The Zener diode is always connected in reverse based on the potential barrier of the p-n junction lies between 0.1 to 0.3 V nearly.

Hence, the answer is the option (3).

Q. 32 A capacitor of capacitance 'C' is connected across an AC source of voltage V given by $V = V_0 \sin \omega t$. The displacement current between the plates of the capacitor would then be given by:

Option 1:

$$I_d = V_0 \omega C \cos \omega t$$

Option 2:

$$I_d = \frac{V_0}{\omega C} \cos \omega t$$

Option 3:

$$I_d = \frac{V_0}{\omega C} \sin \omega t$$

Option 4:

$$I_d = V_0 \omega C \sin \omega t$$

Correct Answer:

$$I_d = V_0 \omega C \sin \omega t$$

Solution:

$$V = V_0 \sin \omega t$$

Displacement current is in magnitude equal to conduction current.

$$I_d = I_c = \frac{V}{X_C} = \frac{V_0 \sin \omega t}{(1/\omega C)}$$

$$I_d = V_0 \omega C (\sin \omega t)$$

Hence, the answer is the option (4).

Q. 33 If E and G respectively denote energy and gravitational constant, then $\frac{E}{G}$ has the dimensions of:

Option 1:
 $[M^2] [L^{-1}] [T^0]$

Option 2:
 $[M] [L^{-1}] [T^{-1}]$

Option 3:
 $[M] [L^0] [T^0]$

Option 4:
 $[M^2] [L^{-2}] [T^{-1}]$

Correct Answer:
 $[M^2] [L^{-1}] [T^0]$

Solution:
 $[E] = [M^1 L^2 T^{-2}]$

$$[G] = \left[\frac{F r^2}{m_1 m_2} \right] = [M^{-1} L^3 T^{-2}]$$

$$\left[\frac{E}{G} \right] = [M^2 L^{-1} T^0]$$

Hence, the answer is the option (1).

Q. 34 A convex lens 'A' of focal length 20 cm and a concave lens 'B' of focal length 5 cm are kept along the same axis with a distance 'd' between them. if a parallel beam of light falling on 'A' leaves 'B' as a parallel beam, then the distance 'd' in cm will be:

Option 1:
25

Option 2:
15

Option 3:
50

Option 4:
30

Correct Answer:

15

Solution:

$$f_A = 20 \text{ cm} \quad f_B = 5 \text{ cm}$$

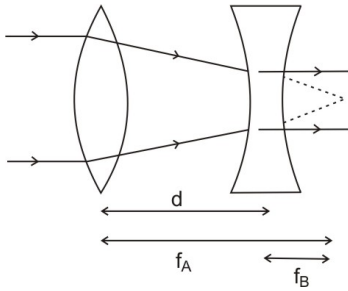

$$f_A - f_B = d$$

$$d = 15 \text{ cm}$$

Q. 35 If force [F], acceleration [A], and time [T] are chosen as the fundamental physical quantities, find the dimensions of energy.

Option 1:

$$[F] [A] [T]$$

Option 2:

$$[F] [A] [T^2]$$

Option 3:

$$[F] [A] [T^{-1}]$$

Option 4:

$$[F] [A^{-1}] [T]$$

Correct Answer:

$$[F] [A] [T^2]$$

Solution:

$$[\text{Energy}] = [F]^x [A]^y [T]^z$$

$$[M^1 L^2 T^{-2}] = [M^1 L^1 T^{-2}]^x [L^1 T^{-2}]^y [T^1]^z$$

$$[M^1 L^2 T^{-2}] = M^x L^{x+y} T^{-2y-2x+z}$$

$$x = 1$$

$$x + y = 2 \quad ; y = 1$$

$$-2x - 2y + z = -2$$

$$z = -2 + 4 = 2$$

$$[\text{Energy}] = [F]^1[A]^1[T]^2$$

Hence, the answer is the option (2).

Q. 36 A Step-Down Transformer connected to an AC mains supply of 220V is made to operate at 11 V,44W lamp. Ignoring power losses in the Transformer, what is current in the primary circuit?

Option 1:

0.2A

Option 2:

0.4A

Option 3:

2A

Option 4:

4A

Correct Answer:

0.2A

Solution:

Since power loss is ignored

$$\eta = 1 = \frac{(\text{power}) \text{ output}}{(\text{power}) \text{ input}}$$

$$P_{\text{input}} = P_{\text{output}}$$

$$V_p I_p = V_s I_s$$

$$I_p = \frac{44}{220} = \frac{1}{5} = 0.2A$$

Hence, the answer is the option (1).

Q. 37 A ball of mas 0.15kg is dropped from a height 10m. strikes to the ground and rebounded to the same height.The magnitude of impluse imparted to the ball is ($g=10m/s^2$) nearly:

Option 1:

0 kg m/s

Option 2:

4.2 kg m/s

Option 3:

2.1 kg m/s

Option 4:

1.4 kg m/s

Correct Answer:

4.2 kg m/s

Solution:

$$m = 0.15 \text{ kg}$$

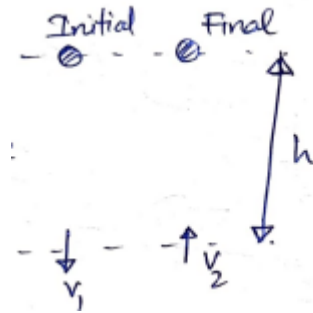

$$h = 10 \text{ m}$$

∴ ball rise to same height

$$V_1 = V_2 = \sqrt{2gh}$$
$$= \sqrt{2 \times 10 \times 10}$$

$$V_1 = V_2 = 10\sqrt{2}$$

$$\text{Impulse} = \Delta P = P_f - P_i$$

$$= (+mv_2) - (-mv_1)$$

$$= (0.15)(v_2 + v_1)$$

$$= (0.15) 20\sqrt{2} = 4.2 \text{ kg} \frac{\text{m}}{\text{s}}$$

Q. 38 A particle moving in a circle of radius R with a uniform speed takes a time T to complete one revolution.

If this particle were projected with the same speed at an angle ' θ ' to the horizontal, the maximum height attained by it equals $4R$. The angle of projection, θ , is then given by :

Option 1:

$$\theta = \cos^{-1} \left(\frac{gT^2}{\pi^2 R} \right)^{\frac{1}{2}}$$

Option 2:

$$\theta = \cos^{-1} \left(\frac{\pi^2 R}{gT^2} \right)^{\frac{1}{2}}$$

Option 3:

$$\theta = \sin^{-1} \left(\frac{\pi^2 R}{gT^2} \right)^{\frac{1}{2}}$$

Option 4:

$$\theta = \sin^{-1} \left(\frac{2gT^2}{\pi^2 R} \right)^{\frac{1}{2}}$$

Correct Answer:

$$\theta = \sin^{-1} \left(\frac{2gT^2}{\pi^2 R} \right)^{\frac{1}{2}}$$

Solution:

$$T = \frac{2\pi R}{V}; V = \frac{2\pi R}{T}$$

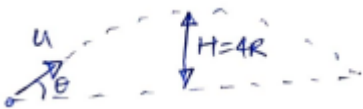

$$H = 4R = \frac{u^2 \sin^2 \theta}{2g}$$

$$u = v$$

$$H = \frac{V^2 \sin^2 \theta}{2g}$$

$$\sin^2 = \frac{2gh}{v^2} = \frac{2gH}{4\pi^2 R^2 T^2}$$

$$\sin \theta = \left(\frac{2gHT^2}{4\pi^2 R^2} \right)^{\frac{1}{2}} = \left(\frac{2g(4g)T^2}{4\pi^2 R^2} \right)^{\frac{1}{2}}$$

$$\sin \theta = \left(\frac{2gT^2}{\pi^2 R} \right)^{\frac{1}{2}}$$

Q. 39 A particle of mass 'm' is projected with a velocity $v = K v_e$ ($K < 1$) from the surface of the earth. ($v_e = \text{escape velocity}$). The maximum height above the surface reached by the particle is :

Option 1:

$$R \left(\frac{K}{1-K} \right)^2$$

Option 2:

$$R \left(\frac{K}{1+K} \right)^2$$

Option 3:

$$\frac{R^2 K}{1+K}$$

Option 4:

$$\frac{RK^2}{1-K^2}$$

Correct Answer:

$$\frac{RK^2}{1-K^2}$$

Solution:

$$v = Kv_e (K < 1)$$

$$TE_1 = TE_2$$

$$\frac{1}{2}mv^2 + \left(-\frac{GMm}{R} \right) = 0 + \left(\frac{-GMm}{R+h} \right)$$

$$\frac{1}{2}m \times K^2 \times \frac{2GM}{R} - \frac{GMm}{R} = \frac{-GMm}{R+h}$$

$$\frac{GMm}{R} [K^2 - 1] = \frac{-GMm}{R+h}$$

$$[1 - K^2] = \frac{R}{R+h}$$

$$\frac{1}{(1 - K^2)} = 1 + \frac{h}{R}$$

$$\frac{K^2 R}{(1 - K^2)} = h$$

Hence, the answer is the option (4).

Q. 40 A car starts from rest and accelerates at 5 m/s^2 . At $t=4\text{s}$, a ball is dropped out of a window by a person sitting in the car. What is the velocity and acceleration of the ball at $t=6\text{s}$?

(Take $g = 10\text{m/s}^2$)

Option 1:

$$20 \text{ m/s}, 5\text{m/s}^2$$

Option 2:

$20\text{ m/s}, 0$

Option 3:

$20\sqrt{2}\text{m/s}, 0$

Option 4:

$20\sqrt{2}\text{m/s}, 10\text{m/s}^2$

Correct Answer:

$20\sqrt{2}\text{m/s}, 10\text{m/s}^2$

Solution:

$u = 0, a = 5\text{m/s}^2$ [along horizontal direction]

at $t = 4\text{s}, v_x = u_x + a_x t$

$$v_x = 20\text{m/s}$$

The ball when released at $t = 4\text{s}$

From $t = 4\text{s}$ to $t = 6\text{s}$

$v_y = 0; v_y = u_y + a_y t$

$$v_y = 0 + (10)(2) = 20\text{m/s}$$

$$a = \sqrt{a_x^2 + a_y^2}$$

$$= \sqrt{0 + (10)^2} = 10\text{m/s}^2$$

$$v = \sqrt{v_x^2 + v_y^2} = \sqrt{(20)^2 + (20)^2}$$

$$v = 20\sqrt{2}\text{m/s}$$

Hence, the answer is the option (4).

Q. 41

A point object is placed at a distance of 60 cm from a convex lens of focal length 30 cm. If a plane mirror were put perpendicular to the principle axis of the lens and at a distance of 40 cm from it, the final image would be formed at the distance of :

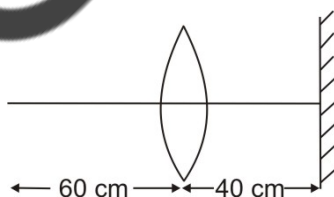

Option 1:

20 cm from the lens, it would be a real image.

Option 2:

30 cm from the lens, it would be a real image .

Option 3:

30 cm from the plane mirror, it would be a virtual image .

Option 4:

20 cm from the plane mirror, it would be a virtual image .

Correct Answer:

20 cm form the lens,it would be real image.

Solution:

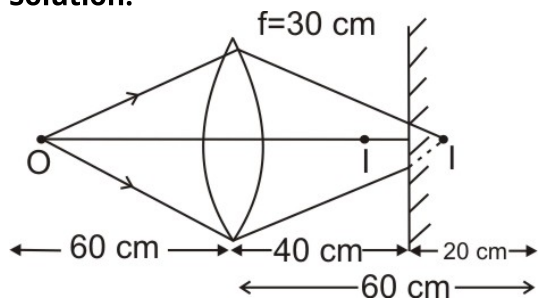

Object at $2f$,image at $2f$

$I \rightarrow$ virtual object for plane mirror

$I' \rightarrow$ Real Image by plane mirror

Q. 42 Twenty seven drops of same size are charged at 220 V each.They combine to form a bigger drop.calculate the potential of the bigger drop.

Option 1:

660V

Option 2:

1320V

Option 3:

1520V

Option 4:

1980V

Correct Answer:

1980V

Solution:

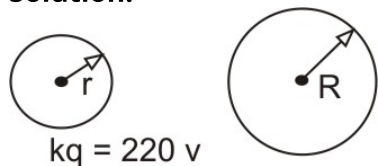

$$V = \frac{kg}{r} = 220v$$

$$27 \times \frac{4}{3}\pi r^3 = \frac{4}{3}\pi R^3$$

$$R = 3r$$

Q Total $27q$ (by Charge conservation)

$$V_{\text{Bigger drop}} = \frac{kQ_{\text{total}}}{R} = \frac{27kq}{3r} \\ = q(220)$$

$$V_{\text{Bigger drop}} = 1980v$$

Q. 43 In the product $\vec{F} = q(\vec{v} \times \vec{B}) = q\vec{v} \times (B\hat{i} + B\hat{j} + B_0\hat{k})$.

For $q = 1$ and $\vec{v} = 2\hat{i} + 4\hat{j} + 6\hat{k}$ $\vec{F} = 4\hat{i} - 20\hat{j} + 12\hat{k}$. What will be the complete expression for \vec{B} ?

Option 1:

$$-8\hat{i} - 8\hat{j} - 6\hat{k}$$

Option 2:

$$-6\hat{i} - 6\hat{j} - 8\hat{k}$$

Option 3:

$$8\hat{i} + 8\hat{j} - 6\hat{k}$$

Option 4:

$$6\hat{i} + 6\hat{j} - 8\hat{k}$$

Correct Answer:

$$-6\hat{i} - 6\hat{j} - 8\hat{k}$$

Solution:

$$\vec{F} = q(\vec{v} \times \vec{B}) = q\vec{v} \times (B\hat{i} + B\hat{j} + B_0\hat{k})$$

$$[4\hat{i} - 20\hat{j} + 12\hat{k}] = [2\hat{i} + 4\hat{j} + 6\hat{k}] \times [B\hat{i} + B\hat{j} + B_0\hat{k}]$$

$$= \hat{i}(4B_0 - 6B) - \hat{j}(2B_0 - 6B) + \hat{k}(-2B)$$

by equating the coefficients of equation ,we get

$$-2B = 12$$

$$B = -6$$

$$4B_0 - 6B = 4$$

$$2B_0 - 6B = 20$$

$$2B_0 = -16, B_0 = -8$$

$$B = -6$$

$$\vec{B} = B\hat{i} + B\hat{j} + B_0\hat{k}$$

$$\vec{B} = -6\hat{i} - 6\hat{j} - 8\hat{k}$$

Hence, the answer is the option (2).

Q. 44 For the given circuit the input digital signals are applied at the terminals A,B and C ,What would be the output at the terminal y?

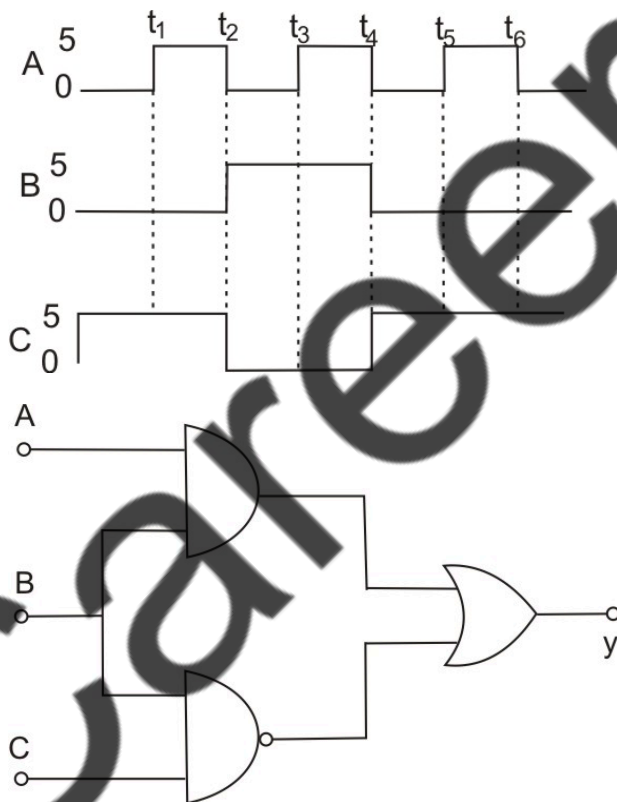

Option 1:

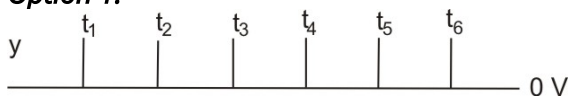

Option 2:

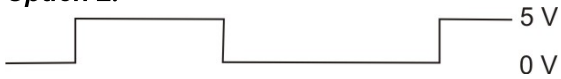

Option 3:



Option 4:



Correct Answer:



Solution:

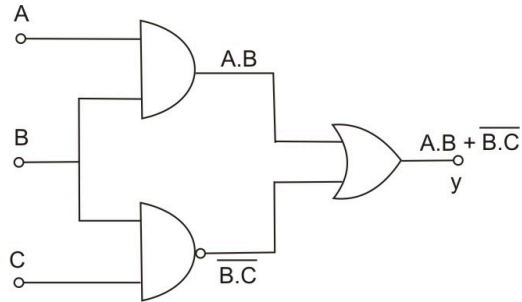

A	B	C	$A.B + \overline{B.C}$ (Y)
○	○		
	○		
○		○	
		○	

Q. 45

A uniform rod of length 200 cm and mass 500 g is balanced on a wedge placed at 40 cm mark. A mass of 2 kg is suspended from the rod at 20 cm and another unknown mass 'm' is suspended from the rod at 160 cm mark as shown in the figure. Find the value of 'm' such that the rod is in equilibrium ($g=10\text{m/s}^2$)

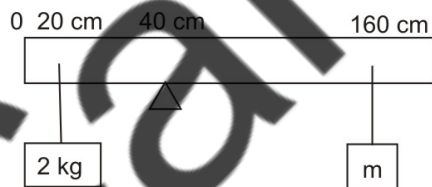

Option 1:

$$\frac{1}{2} \text{ kg}$$

Option 2:

$$\frac{1}{3} \text{ kg}$$

Option 3:

$$\frac{1}{6} kg$$

Option 4:

$$\frac{1}{12} kg$$

Correct Answer:

$$\frac{1}{12} kg$$

Solution:

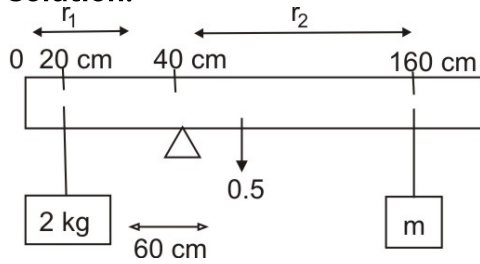

for rotational equilibrium

$$T_1 = T_2$$

$$(2 \times 10) r_1 = (m \times 10) r_2 + (0.5 \times 10) (0.6)$$

$$r_1 = 0.2m \quad r_2 = 1.2m$$

$$2 \times 0.2 - 0.3 = m (1.2)$$

$$\left(m = \frac{1}{12} kg \right)$$

Q. 46 A uniform conducting wire of length $12a$ and resistance ' R ' is wound up as a current carrying coil in the shape of

- (i) an equilateral triangle of side ' a '
- (ii) a square of side ' a '

the magnetic dipole moments of the coil in each case respectively are

Option 1:

$$\sqrt{3}Ia^2 \text{ and } 3Ia^2$$

Option 2:

$$3Ia^2 \text{ and } Ia^2$$

Option 3:

$$3Ia^2 \text{ and } 4Ia^2$$

Option 4:

$$4Ia^2 \text{ and } 3Ia^2$$

Correct Answer:

$$\sqrt{3}Ia^2 \text{ and } 3Ia^2$$

Solution:

$$\text{Length} = 12a$$

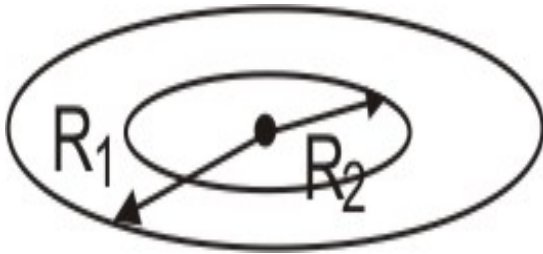

$$M_1 = n_1 I A_1$$

$$4 \times I \left(\frac{1}{2} \times a \times \frac{\sqrt{3}}{2} a \right)$$

$$M_1 = \sqrt{3}Ia^2$$

$$M_2 = n_2 I A_2$$

$$= 3I(a^2)$$

$$M_2 = 3Ia^2$$

Q. 47 Two conducting circular loops of radii R_1 and R_2 are placed in the same plane with their centres coinciding. If $R_1 \gg R_2$, the mutual inductance M between them will be directly proportional to :

Option 1:

$$\frac{R_1}{R_2}$$

Option 2:

$$\frac{R_2}{R_1}$$

Option 3:

$$\frac{R_1^2}{R_2}$$

Option 4:

$$\frac{R_2^2}{R_2}$$

Correct Answer:

$$\frac{R_2^2}{R_2}$$

Solution:



$$\phi = MI$$

$$BA = MI$$

$$\frac{\mu_0 I}{2R_1} \times TIR_2^2 = MI$$

$$M \propto \frac{R_2^2}{R_1}$$

Q. 48 From a circular ring of mass 'M' and radius 'R' an arc corresponding to a 90° sector is removed. The moment of inertia of the remaining part of the ring about an axis passing through the center of the ring and perpendicular to the plane of the ring is 'K'times MR^2 , Then the value of 'K' is :

Option 1:

$$\frac{3}{4}$$

Option 2:

$$\frac{7}{8}$$

Option 3:

$$\frac{1}{4}$$

Option 4:

$$\frac{1}{8}$$

Correct Answer:

$$\frac{3}{4}$$

Solution:

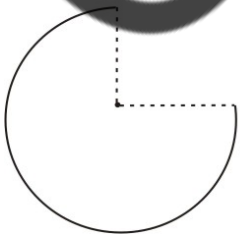

$$\text{Remaining mass} = M' = \frac{3}{4}M$$

$$I = M'R^2 = \frac{3}{4}MR^2 - K MR^2$$

$$K = \frac{3}{4}$$

Q. 49 Three resistance having resistances r_1, r_2 and r_3 are connected as shown in the given circuit. The ratio $\frac{i_3}{i_1}$ of currents in terms of resistances used in the circuit is :

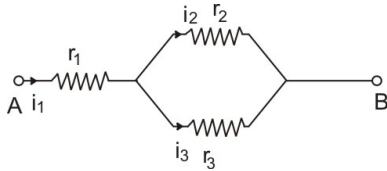

Option 1:
 $\frac{r_1}{r_2 + r_3}$

Option 2:
 $\frac{r_2}{r_2 + r_3}$

Option 3:
 $\frac{r_1}{r_1 + r_2}$

Option 4:
 $\frac{r_2}{r_1 + r_3}$

Correct Answer:
 $\frac{r_2}{r_2 + r_3}$

Solution:

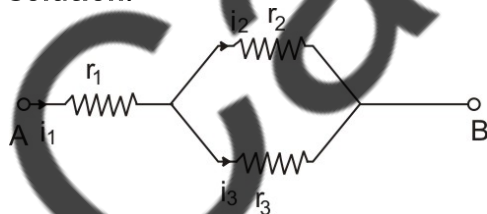

$$i_2 r_2 = i_3 r_3 \text{ [resistance in parallel]}$$

$$i_2 + i_3 = i_1 \text{ [Kirchoff's current law]}$$

$$(i_1 - i_3) r_2 = i_3 r_3$$

$$i_1 r_2 = i_3 (r_3 + r_2)$$

$$\frac{i_3}{i_1} = \frac{r_2}{r_2 + r_3}$$

Q. 50 A series LCR circuit containing 5.0 H inductor $80\mu F$ capacitor and 40Ω resistor is connected to 230 V variable frequency AC source. The angular frequencies of the source at which power transferred to the circuit are half the power at the resonant angular frequency are likely to be :

Option 1:

25 rad/s and 75 rad/s

Option 2:

50 rad/s and 25 rad/s

Option 3:

46 rad/s and 54 rad/s

Option 4:

42 rad/s and 58 rad/s

Correct Answer:

50 rad/s and 25 rad/s

Solution:

$$L = 5H$$

$$C = 80\mu F$$

$$R = 40\Omega$$

$$P = \frac{1}{2}P_0$$

$P_0 \rightarrow$ Power at resonance

$\omega_0 \rightarrow$ Resonance angular frequency

at resonance, $X_c = X_L$

$$\omega_0 C = \frac{1}{\omega_0 L}$$

$$\omega_0 = \frac{1}{\sqrt{LC}} = \frac{1}{20 \times 10^{-3}}$$

$$\omega_0 = 50 \text{ rad/s}$$

$$P = V_{rms} I_{rms} \cos \phi_1$$

$$P_0 = V_{rms} I_{rms} \cos \phi_0$$

$$\cos \phi_0 = \frac{1}{2}$$

$$\cos \phi_1 = \frac{1}{2} \quad \cos \phi_0 = \frac{R}{Z}$$

$$\frac{R}{Z_1} = \frac{1}{2} \quad \phi_o = 0^\circ; \cos \phi_o = 1$$

$$80 = Z_1 = \sqrt{(X_L - X_C)^2 + R^2}$$

$$6400 = (X_L - X_C)^2 + 1600$$

$$4800 = (X_L - X_C)^2$$

$$4800 = \left(wL - \frac{1}{wC} \right)^2$$

$$40\sqrt{3} = \left(wL - \frac{1}{wC} \right)$$

$$w = 25 \text{ rad/s}$$

$$w_o = 50 \text{ rad/s} \quad w = 25 \text{ rad/s}$$

Hence, the answer is the option (2).

Chemistry

Q. 1 Noble gases are named because of their inertness towards reactivity. Identify an incorrect statement about them.

Option 1:

Noble gases are sparingly soluble in water.

Option 2:

Noble gases have very high melting and boiling point.

Option 3:

Noble gases have weak dispersion force.

Option 4:

Noble gases have large positive values of electron gain enthalpy.

Correct Answer:

Noble gases have very high melting and boiling point.

Solution:

Noble gases are usually monoatomic and have very weak interaction forces. They usually have very low melting and boiling points.

The stronger the interaction between particles of gas more boiling and melting points.

Hence, the answer is the option (2).

Q. 2 The correct option for the number of body centred unit cells in all 14 types of Bravais lattice unit cells is:

Option 1:

7

Option 2:

5

Option 3:

2

Option 4:

3

Correct Answer:

3

Solution:

Body-centred unit cells are possible for Orthorhombic, cubic and tetragonal types of Bravais lattice unit cells.

Hence, out of the 14 possible bravais lattice, body-centred unit cells exist for only 3.

Therefore, the correct option is (4).

Q. 3 Which are among the following is the correct option for right relationship between C_p and C_v for one mole of ideal gas?

Option 1:

$$C_p + C_v = R$$

Option 2:

$$C_p - C_v = R$$

Option 3:

$$C_p = RC_v$$

Option 4:

$$C_v = RC_p$$

Correct Answer:

$$C_p - C_v = R$$

Solution:

The relation between C_p and C_v for one mole of an ideal gas is given as

$$C_P - C_V = R.$$

Hence, the answer is the option (3).

Q. 4 Zr(Z=40) and Hf(Z=72) have similar atomic and ionic radii because of:

Option 1:

Belonging to same group

Option 2:

Diagonal relationship

Option 3:

Lanthanoid contraction

Option 4:

Having Similar chemical properties

Correct Answer:

Lanthanoid contraction

Solution:

Zr and Hf have an almost similar size. This is because of Lanthanoid contraction.

Hence, the answer is the option (3).

Q. 5 The Maximum Temperature that can be achieved in a blast furnace is :

Option 1:

Upto 1200 K

Option 2:

Upto 2200 K

Option 3:

Upto 1900 K

Option 4:

Upto 5000 K

Correct Answer:

Upto 2200 K

Solution:

The maximum temperature that can be achieved in a Blast furnace is 2200K.

The correct answer is option 2.

Q. 6 Statement I: Acid strength increases in the order given as
 $HF \ll HCl \ll HBr \ll HI$.

Statement II: As the size of elements F, Cl, Br, I increases down the group, the bond strength of HF , HCl , HBr , and HI decreases and so the acid strength increases

In the light of the above statements, choose the correct answer from the option given below

Option 1:

Both Statement I and Statement II are true

Option 2:

Both Statement I and Statement II are false.

Option 3:

Statement I is correct but Statement II is false.

Option 4:

Statement I is incorrect but Statement II is true.

Correct Answer:

Both Statement I and Statement II are true

Solution:

Statement I and Statement II are both correct.

As the size of the halogen increases, the acidic strength of the hydrogen halide increases.

Also, as the difference in the size of the halogen and hydrogen increases, the bond length increases and the bond dissociation energy decreases.

Lower is bond dissociation energy, more is acidic strength.

The correct answer is option 1.

Q. 7 The compound which shows metamerism is :

Option 1:

C_5H_{12}

Option 2:

C_3H_8O

Option 3:
 C_3H_6O

Option 4:
 $C_4H_{10}O$

Correct Answer:
 $C_4H_{10}O$

Solution:

Metamerism is shown by compounds that can have different alkylation around a central atom or a group.

$C_4H_{10}O$ can show metamerism which can be illustrated as

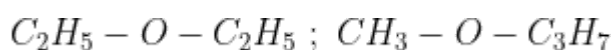

Here the alkylation is different in the compounds around the heteroatom O.

Hence, the answer is the option (4).

Q. 8 For a reaction $A \rightarrow B$, the enthalpy of reaction is -4.2 kJ mol^{-1} and enthalpy of activation is 9.6 kJ mol^{-1} . The correct potential energy profile for the reaction is shown in the option.

Option 1:

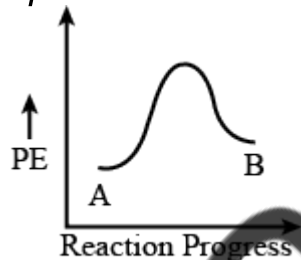

Option 2:

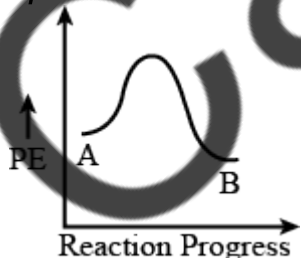

Option 3:

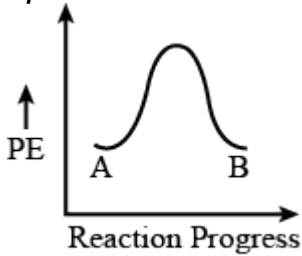

Option 4:

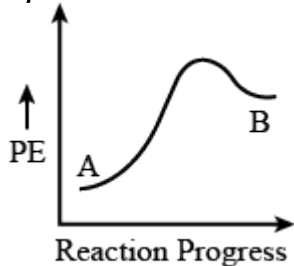

Correct Answer:

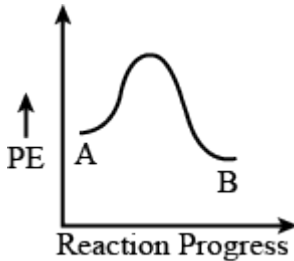

Solution:

For an exothermic reaction, the enthalpy of the reactant will be greater than the enthalpy of the product and as a result, the energy profile diagram will look like

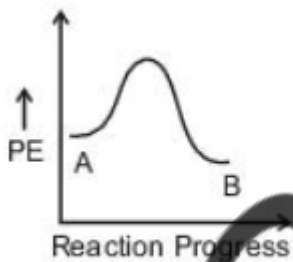

The correct answer is option 2.

Q.9 The right option for the statement "Tyndall effect is exhibited by" is :

Option 1:

NaCl Solution

Option 2:

Glucose solution

Option 3:

Starch Solution

Option 4:

Urea Solution

Correct Answer:

Starch Solution

Solution:

Tyndall effect is shown by Colloidal solutions.

Out of the given solutions, only starch solution can have particles of colloidal size.

Urea, glucose, and NaCl form true solutions and hence, cannot show Tyndall Effect.

The correct answer is option 3.

Q. 10 BF_3 is a planar and electron-deficient compound. Hybridization and number of electrons around the central atom, respectively are:

Option 1:

sp^3 and 4

Option 2:

sp^3 and 6

Option 3:

sp^2 and 6

Option 4:

sp^2 and 8

Correct Answer:

sp^2 and 6

Solution:

BF_3 is a trigonal planar molecule with 3 sigma bonds formed by Boron with the 3 Fluorine atoms.

$$H = \frac{3 + 3}{2} = 3$$

Hence, the hybridization is sp^2 and the number of electrons around boron is 6.

Hence, the answer is the option (3).

Q. 11 Match List -I with List -II

List I	List II
(a) PCl_5	(i) Square pyramidal
(b) SF_6	(ii) Trigonal Planar
(c) BrF_5	(iii) Octahedral
(d) BF_3	(iv) Trigonal bipyramidal

Choose the correct Answer from the given below

Option 1:

(a)-(iv),(b)-(iii),(c)-(i) ,(d)-(ii)

Option 2:

(a)-(ii),(b)-(iii),(c)-(iv),(d)-(i)

Option 3:

(a)-(iii),(b)-(i),(c)-(iv),(d)-(ii)

Option 4:

(a)-(iv),(b)-(iii),(c)-(ii),(d)-(i)

Correct Answer:

(a)-(iv),(b)-(iii),(c)-(i) ,(d)-(ii)

Solution:

To calculate hybridization

$$H = \frac{V + M - Q}{2}$$

Where V is the number of valence electrons in the central atom

M is the Number of surrounding atoms

Q is the charge present on the molecule (if any)

PCl_5 has trigonal bipyramidal shape and sp^3d hybridization.

$$H = \frac{5 + 5}{2} = 5 \quad sp^3d$$

SF_6 has sp^3d^2 hybridization and octahedral geometry.

$$H = \frac{6 + 6}{2} = 6 \quad sp^3d^2$$

BrF_5 has sp^3d^2 hybridization and square pyramidal geometry.

$$H = \frac{7 + 5}{2} = 6 \quad sp^3d^2$$

BF_3 has sp^2 hybridization and trigonal planar geometry.

$$H = \frac{3 + 3}{2} = 3 \quad sp^2$$

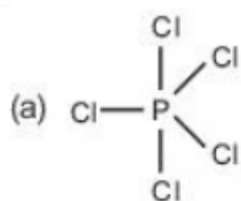

Trigonal Bipyramidal

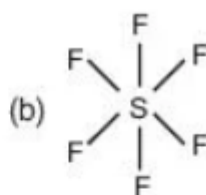

Octahedral

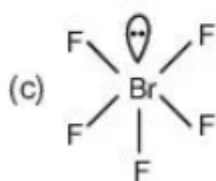

Square Pyramidal



Trigonal Planar

Hence, the correct answer is option 1.

Q. 12 The structures of beryllium chloride in solid state and vapour phase, are

Option 1:

Chain and dimer, respectively

Option 2:

Linear in both

Option 3:

Dimer and Linear, respectively

Option 4:

Chain in both

Correct Answer:

Chain and dimer, respectively

Solution:

BeCl_2 exists as a polymeric solid and a dimeric gas. The structures in the solid state and the gaseous state is given below:

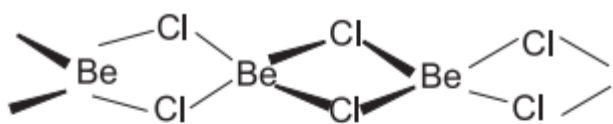

Structure of BeCl_2 Solid

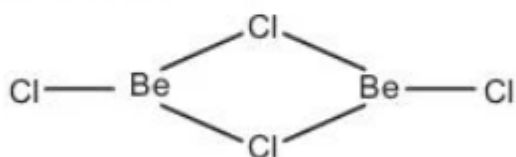

Structure of BeCl_2 dimer in gaseous state

Hence, the correct answer is option 1.

Q. 13 The correct sequence of bond enthalpy of 'C-X' bond is :

Option 1:



Option 2:



Option 3:



Option 4:



Correct Answer:



Solution:

Bond strength depends upon the extent of overlap. As the size difference increases, the bond energy or the bond strength decreases as the overlap becomes less effective.

Thus, as the size of the halogen increases, the C-X bond energy decreases.

Therefore, the correct order is



Hence, the answer is the option (2).

Q. 14 Which one of the following polymers is prepared by addition polymerisation?

Option 1:
Teflon

Option 2:
Nylon - 6,6

Option 3:
Novolac

Option 4:
Dacron

Correct Answer:
Teflon

Solution:

Teflon is Polytetrafluoroethene and it is prepared by the addition polymerisation of tetrafluoroethene.

Nylon, Novolac and Dacron are condensation polymers.

Hence, the correct answer is Option (1)

Q. 15 Dihedral angle of least stable conformer of ethane is :

Option 1:
 120°

Option 2:
 180°

Option 3:
 60°

Option 4:
 0°

Correct Answer:

0°

Solution:

The least stable conformer of ethane is the eclipsed form in which the dihedral angle is Zero.

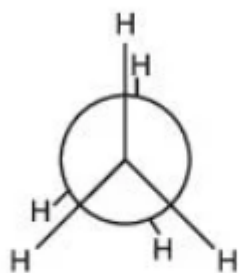

Dihedral angle = 0°

Q. 16 An organic compound contains 78% (by wt.) carbon and remaining percentage of hydrogen. The right option for the empirical formula of this compound is : [Atomic wt.C is 12, H is 1]

Option 1:

CH

Option 2:

CH_2

Option 3:

CH_3

Option 4:

CH_4

Correct Answer:

CH_3

Solution:

The mass ratio of Carbon : Hydrogen = 78 : 22

\therefore the molar ratio of Carbon : Hydrogen = 6.5 : 22

\therefore the simplest ratio of Carbon : Hydrogen = 1 : 3.38

Thus, based on the given data, the most probable answer is CH_3

Hence, the answer is the option (3).

Q. 17 The molar conductance of NaCl, HCl, and CH_3COONa at infinite dilution are 126.45, 426.16 and $91.0 \text{ S cm}^2\text{mol}^{-1}$ respectively. The molar conductance of CH_3COOH at infinite dilution is _____.

Choose the right option for your answer:

Option 1:

$$201.28 \text{ S cm}^2 \text{ mol}^{-1}$$

Option 2:

$$390.71 \text{ S cm}^2 \text{ mol}^{-1}$$

Option 3:

$$698.28 \text{ S cm}^2\text{mol}^{-1}$$

Option 4:

$$540.48 \text{ S cm}^2 \text{ mol}^{-1}$$

Correct Answer:

$$390.71 \text{ S cm}^2 \text{ mol}^{-1}$$

Solution:

Given,

$$\Lambda_m^\circ, \text{NaCl} = 126.45$$

$$\Lambda_m^\circ, \text{HCl} = 426.16$$

$$\Lambda_m^\circ, \text{CH}_3\text{COONa} = 91$$

$$\Lambda_m^\circ, \text{CH}_3\text{COOH} = ?$$

We know from Kohlrausch's Law of independent migration of ions,

$$\Lambda_m^\circ, \text{CH}_3\text{COOH} = \Lambda_m^\circ, \text{CH}_3\text{COONa} + \Lambda_m^\circ, \text{HCl} - \Lambda_m^\circ, \text{NaCl}$$

$$\Lambda_m^\circ, \text{CH}_3\text{COOH} = 91 + 426.16 - 126.45 = 390.71$$

Hence, the answer is the option (2).

Q. 18 Given below are two statements :

Statement I :

Aspirin and Paracetamol belong to the class of narcotic analgesics.

Statement II :

Morphine and Heroin are non-narcotic analgesics.

In the light of the above statements, choose the correct answer from the options given below.

Option 1:

Both **Statement I** and **Statement II** are true.

Option 2:

Both **Statement I** and **Statement II** are false.

Option 3:

Statement I is correct but **Statement II** is false.

Option 4:

Statement I is incorrect but **Statement II** is true.

Correct Answer:

Both **Statement I** and **Statement II** are false.

Solution:

Aspirin and Paracetamol are Non Narcotic analgesics while Morphine and Heroin are Narcotic Analgesics.

Thus, Statement I and II are both incorrect.

Q. 19 The following solutions were prepared by dissolving 10 g of glucose ($C_6H_{12}O_6$) in 250 ml of water (P_1), 10 g of urea (CH_4N_2O) in 250 ml of water (P_2), and 10 g of sucrose ($C_{12}H_{22}O_{11}$) in 250 ml of water (P_3). The right option for the decreasing order of osmotic pressure of these solutions is :

Option 1:

$P_2 > P_1 > P_3$

Option 2:

$P_1 > P_2 > P_3$

Option 3:

$$P_2 > P_3 > P_1$$

Option 4:

$$P_3 > P_1 > P_2$$

Correct Answer:

$$P_2 > P_1 > P_3$$

Solution:

We know that,

$$\pi = CRT$$

So under similar conditions of temperature and volume of solution, the species with the greater number of moles has a greater value of Osmotic Pressure.

Order of moles : Urea > Glucose > Sucrose

Order of Osmotic Pressure:

$$P_2 > P_1 > P_3$$

Hence, the answer is the option (1).

Q. 20 Among the following alkaline earth metal halides, one which is covalent and soluble in organic solvents is :

Option 1:

Calcium chloride

Option 2:

Strontium chloride

Option 3:

Magnesium chloride

Option 4:

Beryllium chloride

Correct Answer:

Beryllium chloride

Solution:

For chlorides of group 2 elements, going down the group covalent character increases. This is because going down the group charge to size ratio decreases and the polarizing power of cation decreases and the lower is polarising power, the more ionic character.

Polarizing power of group 2 elements is $Be^{2+} > Mg^{2+} > Ca^{2+} > Sr^{2+} > Ba^{2+}$

and, the covalent character is

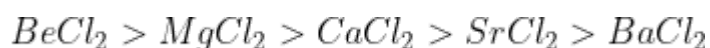

hence, the correct answer is option 4.

Q. 21 Identify the compound that will react with Hinsberg's reagent to give a solid which dissolves in alkali.

Option 1:

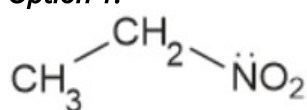

Option 2:

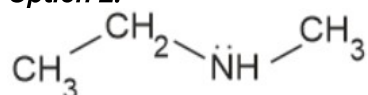

Option 3:

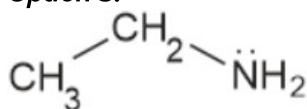

Option 4:

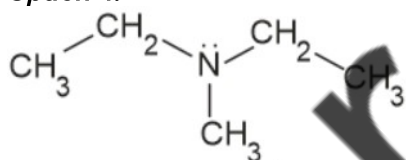

Correct Answer:

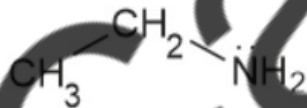

Solution:

Hinsberg's reagent test is given by both primary as well as secondary amines. However, it is the primary amines only that give a product which is soluble in Alkali.

This is because there is an acidic hydrogen ($N - H$) present in the addition product with Benzene Sulphonyl Chloride for a Primary amine.

Q. 22 Right option for the number of tetrahedral and octahedral voids in hexagonal primitive unit cell are :

Option 1:
8, 4

Option 2:
6, 12

Option 3:
2, 1

Option 4:
12, 6

Correct Answer:
12, 6

Solution:

In any closed-packed structure containing N number of particles, the number of Tetrahedral Voids is $2N$ and the number of Octahedral Voids is N .

Now since in a hexagonal closed packed structure, the number of particles is 6, the number of Tetrahedral and Octahedral Voids will be 12 and 6 respectively.

Therefore, the correct option is (4).

Q. 23 The correct structure of 2,6- Dimethyl-dec-4-ene is :

Option 1:

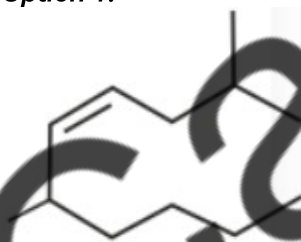

Option 2:



Option 3:

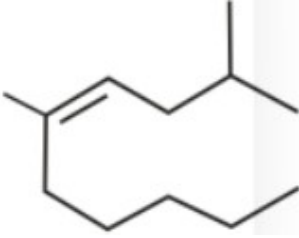

Option 4:

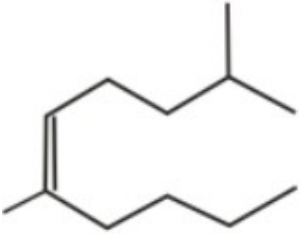

Correct Answer:

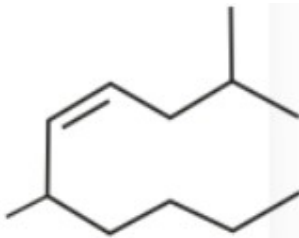

Solution:

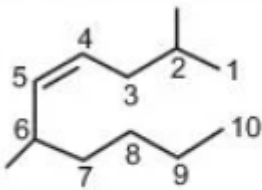

2,6-Dimethyl-dec-4-ene

Q. 24 The RBC deficiency is deficiency disease of :

Option 1:
Vitamin B₁₂

Option 2:
Vitamin B₆

Option 3:
Vitamin B₁

Option 4:
Vitamin B₂

Correct Answer:
Vitamin B₁₂

Solution:

Factual Question.

RBC deficiency is caused by deficiency of Vitamin B₁₂

Q. 25 Which one of the following methods can be used to obtain highly pure metal which is liquid at room temperature?

Option 1:
Electrolysis

Option 2:
Chromatography

Option 3:
Distillation

Option 4:
Zone refining

Correct Answer:
Distillation

Solution:

Distillation is used as a process of refining metals having low boiling points like *Zn*, *Hg* and *Cd*.

Hence, the correct answer is option 3.

Q. 26 What is the IUPAC name of the organic compound formed in the following chemical reaction ?

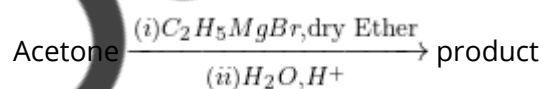

Option 1:
2 methyl propan-2-ol

Option 2:
pentan - 2-ol

Option 4:

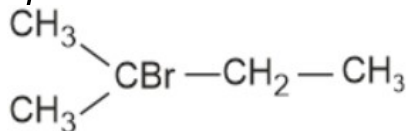

Correct Answer:

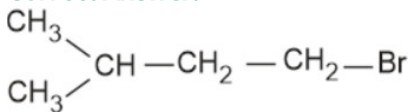

Solution:

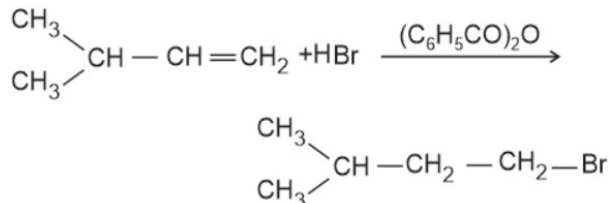

according to antimarkovnikov Rules,

Q. 28 The **incorrect** statement among the following is :

Option 1:

Actionoid contraction is greater for element to element than Lanthanoid contraction.

Option 2:

Most of the trivalent Lanthanoid ions are colorless in the solid state.

Option 3:

Lanthanoids are good conductors of heat and electricity.

Option 4:

Actionoids are highly reactive metals, especially when finely divided.

Correct Answer:

Most of the trivalent Lanthanoid ions are colorless in the solid state.

Solution:

Most of the trivalent lanthanoids are Colored in both the Solid as well as the aqueous state.

Other statements are all correct.

Hence, the answer is the option (2).

Q. 29 A particular station of All India Radio, New Dehli, broadcasts on a frequency of 1,368 kHz (kilohertz), the wavelength of the electromagnetic radiation emitted by the transmitter is : [speed of light, $c = 3.0 \times 10^8 \text{ms}^{-1}$].

Option 1:
219.3 m

Option 2:
219.2 m

Option 3:
2192 m

Option 4:
21.92 cm

Correct Answer:
219.3 m

Solution:

We know that,

$$\nu = \frac{c}{\lambda}$$

$$\therefore \lambda = \frac{c}{\nu} = \frac{3 \times 10^8 \text{ m/s}}{1368 \times 10^3 \text{ s}} = 219.3 \text{ m}$$

Hence, the answer is the option (1).

Q. 30 Which of the following reactions is the metal displacement reaction ? Choose the right option.

Option 1:



Option 2:

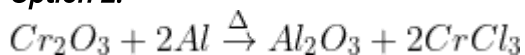

Option 3:

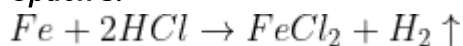

Option 4:

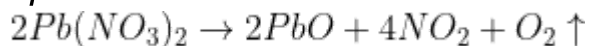

Correct Answer:

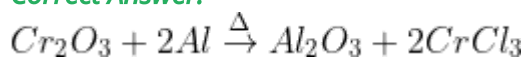

Solution:

Decomposition reaction leads to the breakdown of a compound into two or more components at least one of which must be in the elemental state.

Both reactions (1) and (4) are examples of decomposition reactions.

In a **displacement reaction**, an ion (or an atom) in a compound is replaced by an ion (or an atom) of another element. There are two types of displacement reactions:

Metal displacement - A metal in a compound can be displaced by another metal in the uncombined state

Non-metal displacement - The non-metal displacement redox reactions include hydrogen displacement and a rarely occurring reaction involving oxygen displacement.

Reactions (2) and (3), both are examples of displacement reactions,

But reaction (2) is an example of a metal displacement reaction because metal is displacing there.

Therefore, the correct option is (2).

Q. 31 Choose the correct option for graphical representation of Boyle's law, which shows a graph of pressure vs. volume of a gas at different temperatures:

Option 1:

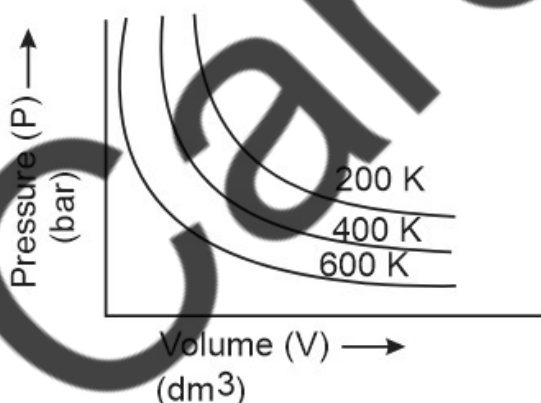

Option 2:

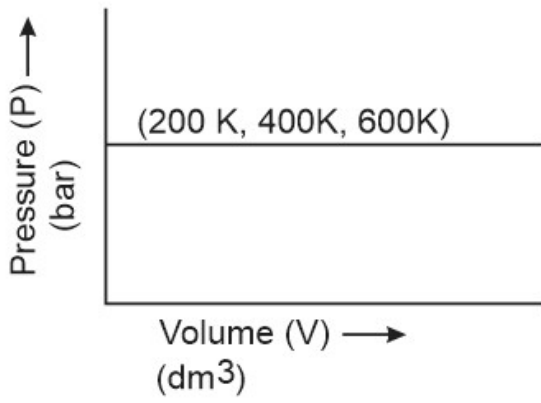

Option 3:

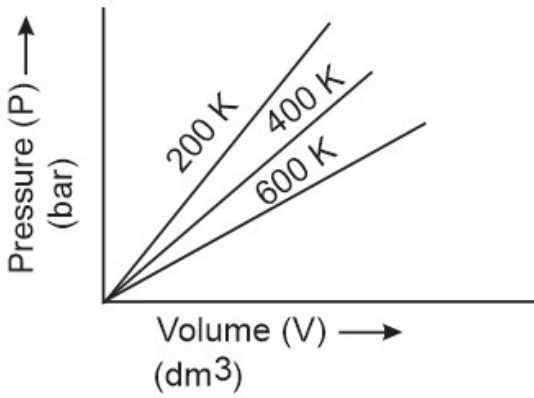

Option 4:

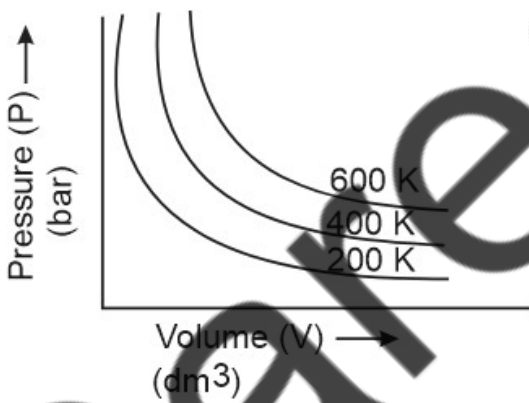

Correct Answer:

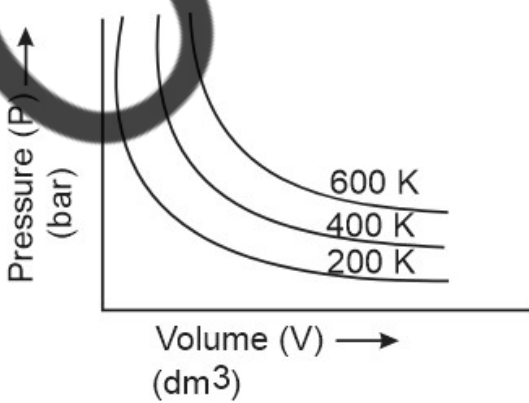

Solution:

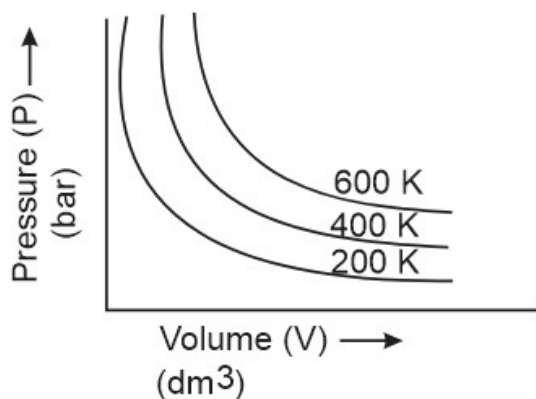

Boyle's Law is -

at a constant temperature, the pressure of a fixed amount (i.e., number of moles n) of gas varies inversely with its volume.

$$P \propto \frac{1}{V} \Rightarrow P = \frac{k}{V} \Rightarrow PV = k$$

Where k is proportionality constant and equal to nRT .

The graph between P vs. V should be a rectangular hyperbola.

If T increases the value of k increases then at the same value of V , P will increase due to k increases.

Therefore, the correct option is (4).

Q. 32 The pK_b of dimethylamine and pK_a of acetic acid are 3.27 and 4.77 respectively at $T(K)$. The correct option for the pH of dimethylammonium acetate solution is :

Option 1:

8.50

Option 2:

5.50

Option 3:

7.75

Option 4:

6.25

Correct Answer:

7.75

Solution:

We know the formula for the pH of salt of the weak acid and weak base -

$$\text{pH} = 7 + \frac{1}{2} (\text{pK}_a - \text{pK}_b)$$

Given,

$$\text{pK}_a = 3.27 \text{ and } \text{pK}_b = 4.77$$

So,

$$\text{pH} = 7 + \frac{1}{2} (4.77 - 3.27)$$

$$\text{pH} = 7.75$$

Hence, the answer is the option (3).

Q. 33 The major product formed in dehydrohalogenation reaction of 2-Bromo pentane is Pent - 2-ene. This product formation is based on ?

Option 1:
Saytzeff's Rule

Option 2:
Hund's Rule

Option 3:
Hofmann Rule

Option 4:
Huckel's Rule

Correct Answer:
Saytzeff's Rule

Solution:
Saytzeff's Rules:

" More substituted alkene is the major product"

Hence, the answer is the option (1).

Q. 34 Ethylene diaminetetraacetate (EDTA) ion is :

Option 1:

Hexadentate ligand with four "O" and two "N" donor atoms

Option 2:

Unidentate ligand

Option 3:

Bidentate ligand with two "N" donor atoms

Option 4:

Tridentate ligand with three "N" donor atoms

Correct Answer:

Hexadentate ligand with four "O" and two "N" donor atoms

Solution:

The structure of EDTA is -

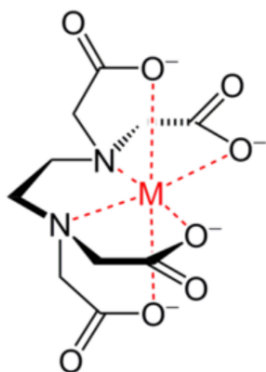

It is a Hexadentate ligand with four "O" and two "N" donor atoms.

Therefore, the correct option is (1).

Q. 35 Tritium, a radioactive isotope of hydrogen, emits which of the following particles?

Option 1:

Beta (β^-)

Option 2:

Alpha (α)

Option 3:

Gamma (γ)

Option 4:

Neutron (n)

Correct Answer:

Beta (β^-)

Solution:

Tritium is a radioactive isotope of Hydrogen and it emits low-energy Beta particles (β^-).

Therefore, the correct option is (1).

Q. 36 Match List - I with List - II

List - I	List - II
(a) $[Fe(CN)_6]^{3-}$	(i) 5.92 BM
(b) $[Fe(H_2O)_6]^{3+}$	(ii) 0 BM
(c) $[Fe(CN)_6]^{4-}$	(iii) 4.90 BM
(d) $[Fe(H_2O)_6]^{2+}$	(iv) 1.73 BM

Choose the correct options from the given below:

Option 1:

(a) - (iv), (b) - (ii), (c) - (i), (d) - (iii)

Option 2:

(a) - (ii), (b) - (iv), (c) - (iii), (d) - (i)

Option 3:

(a) - (i), (b) - (iii), (c) - (iv), (d) - (ii)

Option 4:

(a) - (iv), (b) - (i), (c) - (ii), (d) - (iii)

Correct Answer:

(a) - (iv), (b) - (i), (c) - (ii), (d) - (iii)

Solution:

CN^- is a strong field ligand and will cause pairing while H_2O is a weak field ligand and will not cause pairing

Thus, Fe^{3+} which has d^5 configuration and will have 1 unpaired electron in the complex with CN^- and 5 unpaired electrons in the complex with H_2O

And, Fe^{2+} which has d^6 configuration and will have 0 unpaired electron in the complex with CN^- and 4 unpaired electrons in the complex with H_2O

Complex	unpaired electrons (n)	Magnetic moment (BM)
$[Fe(CN)_6]^{3-}$	1	1.73
$[Fe(H_2O)_6]^{3+}$	5	5.92
$[Fe(CN)_6]^{4-}$	0	0
$[Fe(H_2O)_6]^{2+}$	4	4.9

Hence, the answer is the option (4).

Q. 37 In which one of the following arrangements the given sequence is not strictly according to the properties indicated against it ?

Option 1:

$HF < HCl < HBr < HI$: Increasing acidic strength

Option 2:

$H_2O < H_2S < H_2Se < H_2Te$: Increasing pK_a values

Option 3:

$NH_3 < PH_3 < AsH_3 < SbH_3$: Increasing acidic character

Option 4:

$CO_2 < SiO_2 < SnO_2 < PbO_2$: Increasing oxidizing power

Correct Answer:

$H_2O < H_2S < H_2Se < H_2Te$: Increasing pK_a values

Solution:

(1) is correct. On moving down the group, acidic strength increases

(2) is incorrect. The greater the acidic strength, the greater the K_a value and the lesser the pK_a value.

(3) is correct. On moving down the group, acidic strength increases

(4) is correct. On moving down group 14, the stability of the +4 oxidation state decreases and the tendency to accept electrons increases. Thus, the oxidizing power increases

Hence, the answer is the option (2).

Q. 38 Choose the correct option for the total pressure (in atm.) in a mixture of 4 g O_2 and 2 g H_2 confined in a total volume of one liter at $0^\circ C$ is :

[Given $R = 0.082L \text{ atm mol}^{-1}K^{-1}, T = 273 K$]

Option 1:
2.518

Option 2:
2.602

Option 3:
25.18

Option 4:
26.02

Correct Answer:
25.18

Solution:

In the question, the pressure needed to find, Volume, and Temperature are given.

We can use $PV = nRT$ formula.

$V = 1$ litre

$T = 0^\circ C = 273 K$

$n = \text{mole} = \text{mass}/\text{molar mass}$

mass is given of each. and molar mass we know that.

So,

$$n_{O_2} = \frac{4}{32} = \frac{1}{8}$$

$$n_{H_2} = \frac{2}{2} = 1$$

So, total moles will be -

$$n_t = \frac{1}{8} + 1 = \frac{9}{8}$$

The formula will be for mixture -

$$P_t V = n_t RT$$

$$P_t \times 1 = \frac{9}{8} \times 0.082 \times 273$$

$$P_t = 25.18 \text{ atm}$$

Therefore, the correct option is (3).

Q. 39 Which of the following molecules is non-polar in nature ?

Option 1:
 $POCl_3$

Option 2:
 CH_2O

Option 3:
 $SbCl_5$

Option 4:
 NO_2

Correct Answer:
 $SbCl_5$

Solution:

$SbCl_5$ molecule is non-polar in nature due to its symmetrical shape -

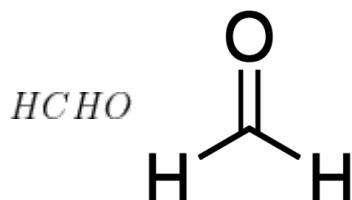
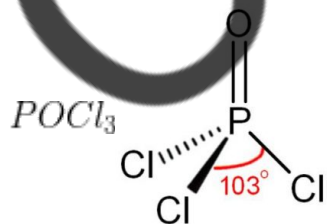

NO_2 has a bent shape and asymmetric hence is also polar in nature.,

Therefore, the correct option is (3).

Q. 40 The product formed in the following chemical reaction is :

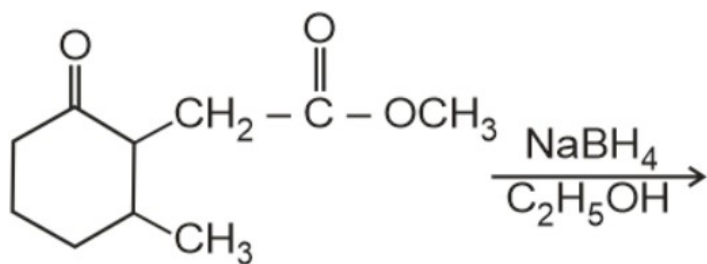

Option 1:

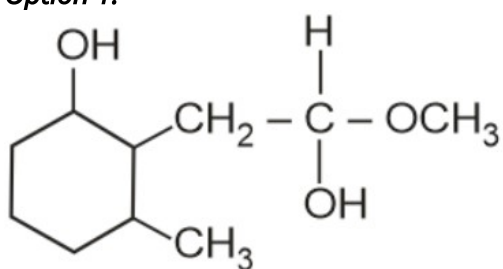

Option 2:

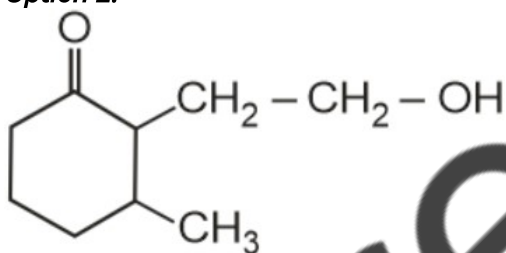

Option 3:

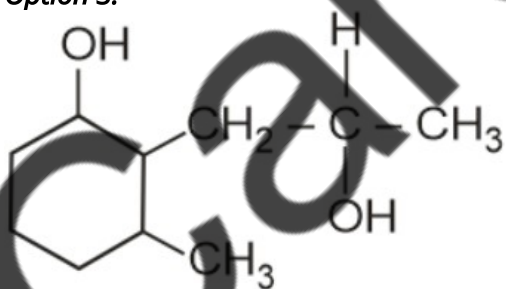

Option 4:

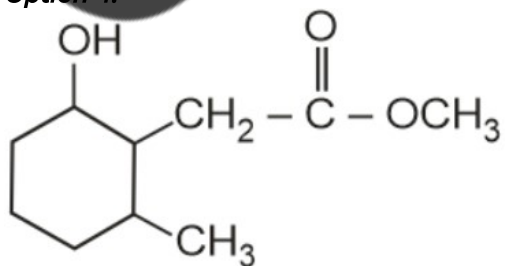

Correct Answer:

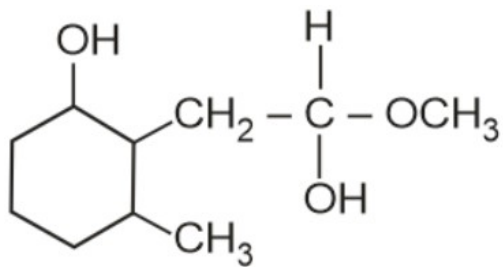

Solution:

$\text{NaBH}_4/\text{C}_2\text{H}_5\text{OH}$ is a weak reducing agent. It cannot reduce $-\text{COOR}$ group

It reduces $\begin{array}{c} \text{---C---} \\ \parallel \\ \text{O} \end{array}$ group to $\begin{array}{c} \text{---CH---} \\ | \\ \text{OH} \end{array}$ group

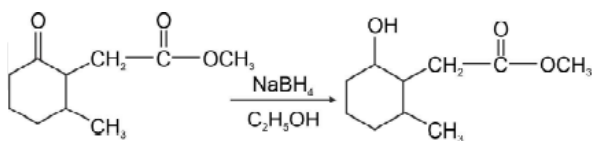

Q. 41 The slope of the Arrhenius Plot $\ln k$ v/s $\frac{1}{T}$ the first-order reaction is $-5 \times 10^3 \text{K}$. The value of E_a of the reaction is. Choose the correct option for your answer.

[Given $R = 8.314 \text{JK}^{-1}\text{mol}^{-1}$]

Option 1:

41.5 kJ mol^{-1}

Option 2:

83.0 kJ mol^{-1}

Option 3:

166 kJ mol^{-1}

Option 4:

-83 kJ mol^{-1}

Correct Answer:

41.5 kJ mol^{-1}

Solution:

We know the Arrhenius equation

$$k = Ae^{-E_a/RT}$$

$$\ln k = \ln A + \ln e^{-E_a/RT}$$

$$\ln k = \ln A - \frac{E_a}{R} \left(\frac{1}{T} \right)$$

The slope of $\left(\ln k \text{ v/s } \frac{1}{T} \right)$ of the above equation -

$$m = -\frac{E_a}{R}$$

Given, $m = -5 \times 10^3 \text{ K}$ and $R = 8.314 \text{ JK}^{-1} \text{ mol}^{-1}$

$$-5 \times 10^3 = -\frac{E_a}{8.314}$$

$$E_a = 5 \times 10^3 \times 8.314 \text{ J/mol}$$

$$E_a = 41.57 \times 10^3 \text{ J/mol}$$

$$E_a \simeq 41.5 \text{ kJ/mol}$$

Hence, the answer is the option (1).

Q. 42 Match List - I with List - II

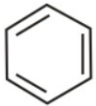
List - I	List - II
(a)  $\xrightarrow[\text{Anhyd, AlCl}_3, \text{CuCl}]{\text{CO, HCl}}$	(i) Hell - Volhard - Zelinsky reaction
(b) $\text{R} - \overset{\text{O}}{\parallel}{\text{C}} - \text{CH}_3 + \text{NaOX}$	(ii) Gattermann - Koch reaction
(c) $\text{R} - \text{CH}_2 - \text{OH} + \text{R}'\text{COOH} \xrightarrow{\text{Conc. H}_2\text{SO}_4}$	(iii) Haloform reaction
(d) $\text{R} - \text{CH}_2\text{COOH} \xrightarrow[\text{(ii) H}_2\text{O}]{\text{(i) X}_2/\text{Red P}}$	(iv) Esterification

Choose the correct answer from the options given below.

Option 1:

(a)-(iv), (b)-(i), (c)- (ii), (d)-(iii)

Option 2:

(a) - (iii), (b)-(ii), (c)- (i), (d)-(iv)

Option 3:

(a) - (i), (b)-(iv), (c)- (iii), (d)-(ii)

Option 4:

(a) - (ii), (b)-(iii), (c)- (iv), (d)-(i)

Correct Answer:

(a) - (ii), (b)-(iii), (c)- (iv), (d)-(i)

Solution:

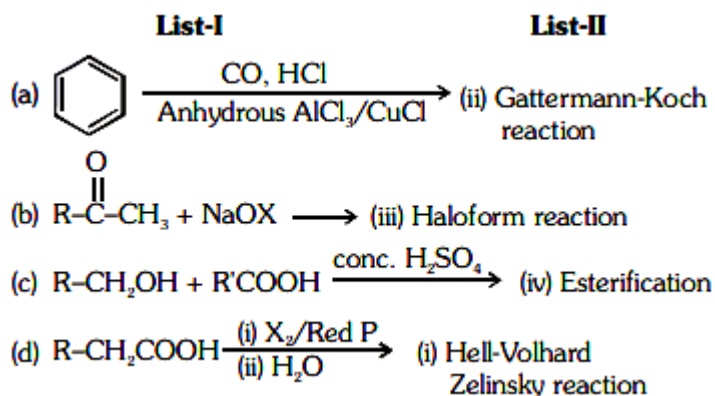

Correct answer is **option (4)**.

Q. 43 For the irreversible expansion of an ideal gas under isothermal conditions, the correct option is :

Option 1:

$$\Delta U = 0, \Delta S_{total} = 0$$

Option 2:

$$\Delta U \neq 0, \Delta S_{total} \neq 0$$

Option 3:

$$\Delta U = 0, \Delta S_{total} \neq 0$$

Option 4:

$$\Delta U \neq 0, \Delta S_{total} = 0$$

Correct Answer:

$$\Delta U = 0, \Delta S_{total} \neq 0$$

Solution:

For irreversible expansion of an ideal gas under isothermal conditions -

We know, for a spontaneous process, $\Delta S_{\text{total}} > 0$ and since the irreversible process is always spontaneous, therefore $\Delta S_{\text{total}} > 0$.

And $\Delta T = 0$ for the isothermal process.

Now, $\Delta U = nC_V\Delta T$

So, $\Delta U = 0$

Correct option $\Delta U = 0, \Delta S_{\text{total}} \neq 0$.

Hence, the answer is the option (3).

Q. 44 The Intermediate compound 'X' in the following chemical reaction is:

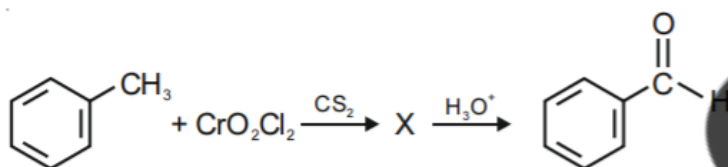

Option 1:

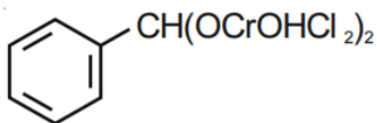

Option 2:

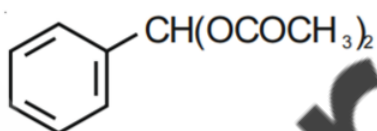

Option 3:

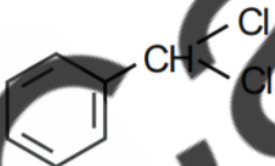

Option 4:

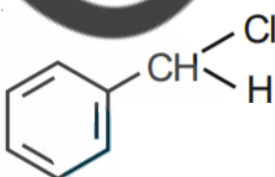

Correct Answer:

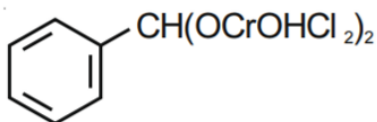

Solution:

The reaction will be -

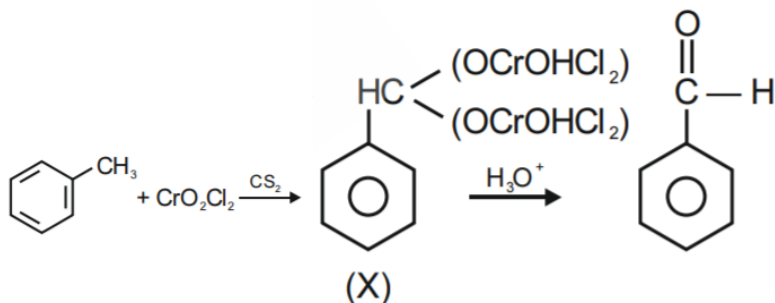

Therefore, the correct option is (1).

Q. 45 Match List - I with List - II.

List - I	List - II
(a) $2SO_2(g) + O_2(g) \rightarrow 2SO_3(g)$	(i) Acid rain
(b) $HOCl(g) \xrightarrow{h\nu} \dot{O}H + \dot{Cl}$	(ii) Smog
(c) $CaCO_3 + H_2SO_4 \rightarrow CaSO_4 + H_2O + CO_2$	(iii) Ozone depletion
(d) $NO_2(g) \xrightarrow{h\nu} NO(g) + O(g)$	(iv) Troposphere pollution

Choose the correct answer from the options given below.

Option 1:

(a) - (i), (b)-(ii), (c)-(iii), (d)-(iv)

Option 2:

(a) - (ii), (b)-(iii), (c)-(iv), (d)-(i)

Option 3:

(a) - (iv), (b)-(iii), (c)-(i), (d)-(ii)

Option 4:

(a) - (iii), (b)-(ii), (c)-(iv),(d)-(i)

Correct Answer:

(a) - (iv), (b)-(iii), (c)-(i),(d)-(ii)

Solution:

We know about these reaction -

- (a) $2SO_2(g) + O_2(g) \rightarrow 2SO_3(g)$ - (iv) Troposphere pollution
(b) $HOCl(g) \xrightarrow{h\nu} \dot{O}H + \dot{Cl}$ - (iii) Ozone depletion
(c) $CaCO_3 + H_2SO_4 \rightarrow CaSO_4 + H_2O + CO_2$ - (i) Acid rain
(d) $NO_2(g) \xrightarrow{h\nu} NO(g) + O(g)$ - (ii) Smog

So, the correct match will be

(a) - (i), (b)-(ii), (c)-(iii),(d)-(iv)

Therefore, the correct option is (3)

Q. 46 The molar conductivity of 0.007 M acetic acid is $20 \text{ S cm}^2 \text{ mol}^{-1}$. What is the dissociation constant of acetic acid? Choose the correct option.

$$\left[\begin{array}{l} \Lambda_{H^+}^\circ = 350 \text{ S cm}^2 \text{ mol}^{-1} \\ \Lambda_{CH_3COO^-}^\circ = 50 \text{ S cm}^2 \text{ mol}^{-1} \end{array} \right]$$

Option 1:

$1.75 \times 10^{-4} \text{ mol L}^{-1}$

Option 2:

$2.50 \times 10^{-4} \text{ mol L}^{-1}$

Option 3:

$1.75 \times 10^{-5} \text{ mol L}^{-1}$

Option 4:

$2.50 \times 10^{-5} \text{ mol L}^{-1}$

Correct Answer:

$1.75 \times 10^{-5} \text{ mol L}^{-1}$

Solution:

Given,

$$\Lambda_m = 20 \text{ S cm}^2 \text{ mol}^{-1}$$

$$\Lambda_m^\circ \text{CH}_3\text{COOH} = \Lambda_{\text{CH}_3\text{COO}^-}^0 + \Lambda_{\text{m}^+}^0$$

$$\Lambda_m^\circ \text{CH}_3\text{COOH} = 50 + 350 = 400 \text{ S cm}^2 \text{ mol}^{-1}$$

$$\alpha = \frac{\Lambda_m}{\Lambda_m^\circ} = \frac{20}{400} = \frac{1}{20}$$

$$K_a = \frac{C\alpha^2}{1-\alpha} \simeq C\alpha^2 = 7 \times 10^{-3} \times \left(\frac{1}{20}\right)^2$$

$$K_a = 7 \times 10^{-3} \times \frac{1}{4} \times 10^{-2}$$

$$K_a = 1.75 \times 10^{-5} \text{ mol L}^{-1}$$

Hence, the answer is the option (3).

Q. 47 From the following pairs of ions which one is not an iso-electronic pair ?

Option 1:

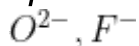

Option 2:

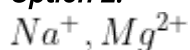

Option 3:

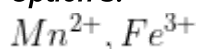

Option 4:

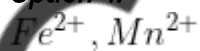

Correct Answer:

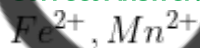
**Solution:**

The number of electrons present in the given ions-

$$\text{O}^{2-} \Rightarrow 18$$

$$\text{F}^- \Rightarrow 18$$

$$\text{Na}^+ \Rightarrow 10$$

$Mg^{2+} \Rightarrow 10$

$Mn^{2+} \Rightarrow 23$

$Fe^{3+} \Rightarrow 23$

$Fe^{2+} \Rightarrow 24$

So, the pair of Fe^{2+} , Mn^{2+} ions is not iso-electronic.

Hence, the answer is the option (4).

Q. 48 The reagent 'R' in the given sequence of chemical reaction is:

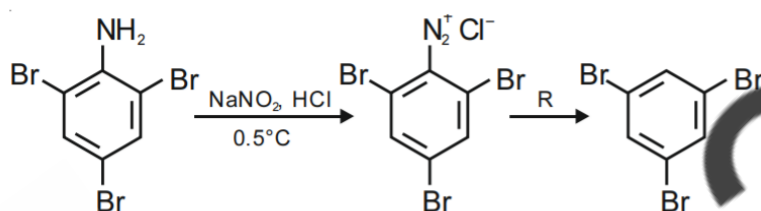

Option 1:

H_2O

Option 2:

CH_3CH_2OH

Option 3:

HI

Option 4:

$CuCN/KCN$

Correct Answer:

CH_3CH_2OH

Solution:

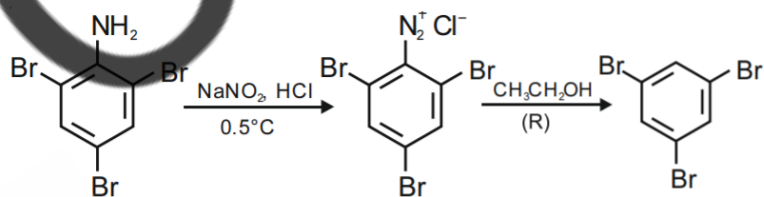

Here CH_3CH_2OH will be R.

Therefore, the correct option is (2).

Q. 49 The correct option for the value of vapour pressure of a solution at 45°C with benzene to octane in molar ratio 3:2 is :

[At 45°C vapour pressure of benzene is 280 mm Hg and that of octane is 420 mm Hg. Assume Ideal gas]

Option 1:

160 mm of Hg

Option 2:

168 mm of Hg

Option 3:

336 mm of Hg

Option 4:

350 mm of Hg

Correct Answer:

336 mm of Hg

Solution:

We know this formula for vapour pressure of a solution -

$$P_{\text{Total}} = \chi_A P_A + \chi_B P_B$$

At 45°C ,

vapour pressure of benzene (P_A) = 280 mm Hg

vapour pressure of octane (P_B) = 420 mm Hg

Given, benzene to octane in molar ratio 3:2

So,

$$P = \frac{3}{3+2} \times 280 + \frac{2}{3+2} \times 420$$

$$P = 168 + 168$$

$$P = 336$$

Therefore, the correct option is (3).

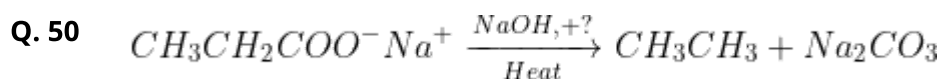

Consider the above reaction and identify the missing reagent/chemical.

Option 1:

B_2H_6

Option 2:

Red Phosphorus

Option 3:

CaO

Option 4:

DIBAL-H

Correct Answer:

CaO

Solution:

The reaction will be -

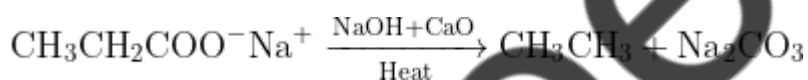

by heating, the sodium salt of the carboxylic acid with soda lime (NaOH and CaO in the ratio of 3: 1), Alkane is produced.

Hence, the answer is the option (3).

Biology

Q. 1 Which of the following algae contains **mannitol** as reserve food material?

Option 1:

Ectocarpus

Option 2:

Graciliaria

Option 3:

Volvox

Option 4:
Ulothrix

Correct Answer:
Ectocarpus

Solution:

Ectocarpus, a type of brown algae, contains mannitol as a reserve food material. Mannitol is a sugar alcohol that serves as a storage carbohydrate in certain algae and plants. Hence, the correct answer is option 1:

Q. 2 Amensalism can be represented as:

Option 1:
Species A (-) : Species B (0)

Option 2:
Species A (+) : Species B (+)

Option 3:
Species A (-) : Species B (-)

Option 4:
Species A (+) : Species B (0)

Correct Answer:
Species A (-) : Species B (0)

Solution:

Amensalism: It is an interaction between two organisms of different species in which one species inhibits the growth of other species by secreting certain chemicals.

A(-) is inhibited

B(0) is unaffected.

Q. 3 Match List -I with List - II.

List -I	List - II
(a) Cristae	(i) Primary constriction in chromosome.
(b) Thylakoids	(ii) Disc - shaped sacs in Golgi apparatus
(c) Centromere	(iii) Infoldings in mitochondria
(d) Cisternae	(iv) Flattered membranes sacs in stromn in plastids

Choose the correct answer from the options given below.

Option 1:

(a) - (iv), (b) - (iii), (c) - (ii), (d) - (i)

Option 2:

(a) - (i), (b) - (iv), (c) - (iii), (d) - (ii)

Option 3:

(a) - (iii), (b) - (iv), (c) - (i), (d) - (ii)

Option 4:

(a) - (ii), (b) - (iii), (c) - (iv), (d) - (i)

Correct Answer:

(a) - (iii), (b) - (iv), (c) - (i), (d) - (ii)

Solution:

Cristae: Infoldings in mitochondria. **To increase the capacity of the mitochondrion to synthesize ATP**, the inner membrane of mitochondria is folded to form cristae. These folds allow a much greater amount of electron transport chain enzymes and ATP synthase to be packed into the mitochondrion.

Thylakoids: are **membrane-bound compartments inside chloroplasts and cyanobacteria**. They are the site of the light-dependent reactions of photosynthesis. Thylakoids consist of a thylakoid membrane surrounding a thylakoid lumen.

Centromere: Primary constriction in **chromosome**. The two chromatids of chromosomes are attached to each other by a narrow area called centromere, also called **primary constriction**. This decides the ratio of arm length called **centromeric index**.

Cisternae: Disc - shaped sacs in **Golgi apparatus**. These appear in the form of flat, curved, smooth membrane structures with swollen ends. They have a definite polarity. Their **convex pole** or **proximal pole** or **cis face** is associated with nuclear envelope. The **concave pole** or **distal pole** or **trans face**, is the oldest, which give rise to the **secondary vesicles**.

Q. 4 The plant hormone used to destroy weeds in a field is :

Option 1:

IAA

Option 2:

NAA

Option 3:

2,4 -D

Option 4:

IBA

Correct Answer:

2,4 -D

Solution:

The 2,4-dichlorophenoxyacetic acid (**2,4-D**) is a **synthetic auxin that has been historically used as one of the most common herbicides to control broadleaf weeds**. At the same time, it also has good potential to enhance storage life and quality of fruits.

Q. 5 Diadelphous stamens are found in:

Option 1:

China Rose

Option 2:

Citrus

Option 3:

Pea

Option 4:

China rose and citrus

Correct Answer:

Pea

Solution:

Monadelphous stamens are seen in china rose, these stamens have a single bunch of filaments.

The plants in which the stamen or anthers are present in three or more than three bundles are known as **polyadelphous stamen**. This type of arrangement is commonly observed in **citrus fruits like lemon**.

Diadelphous stamens are found in pea, having united filaments so that they are arranged in two groups.

Q. 6 A typical angiosperm embryo sac at maturity:

Option 1:

8 - nucleate and 7-celled

Option 2:

7 - nucleate and 8-celled

Option 3:

7- nucleate and 7-celled

Option 4:

8 - nucleate and 8-celled

Correct Answer:

8 - nucleate and 7-celled

Solution:

Nucleus of functional megaspore divides by three mitotic divisions to form 8 nuclei, out of which

(i) Three of them get organised as cells at micropylar end forming egg apparatus. One is **egg cell** (n) and two are **synergids** (n) or co-operative cells.

(ii) Three cells at chalazal end form **antipodals** (n) or vegetative cells of female gametophyte.

(iii) Two nuclei (one from each pole) in the centre are called **polar nuclei** (n).

As the mebro sac matures, these polar nuclei get fused to form a **secondary nucleus** (2n) or definite nucleus.

This constitutes an embryo sac as **7-celled and 8-nucleated** structure.

Q. 7 Which of the following is correct sequence of steps in PCR (Polymearse Chain Reaction)?

Option 1:

Denaturation, Annealing , Extenstion

Option 2:

Denaturation, Extension, Annealing

Option 3:

Extension, Denaturation, Annealing

Option 4:

Annealing, Denaturation, Extension

Correct Answer:

Denaturation, Annealing , Extension

Solution:

PCR is based on three simple steps required for any DNA synthesis reaction:

- (1) denaturation of the template into single strands;
- (2) annealing of primers to each original strand for new strand synthesis; and
- (3) extension of the new DNA strands from the primers.

Q. 8 The site of perception of light in plants during photoperiodism is:

Option 1:

Shoot apex

Option 2:

Stem

Option 3:

Axillary bud

Option 4:

Leaf

Correct Answer:

Leaf

Solution:

The site of perception of photoperiod is **leaves**. The hormone **florigen**, which is responsible for flowering, induces flowering as it migrates from leaves to shoot apices on induction of required photoperiods.

Q. 9 Which of the following is incorrect statement?

Option 1:

Mature sieve tube elements possess a conspicuous nucleus and usual cytoplasmic organelles.

Option 2:

Microbodies are present both in plants and animals cells.

Option 3:

The perinuclear space forms a barrier between the materials present inside the nucleus and the cytoplasm.

Option 4:

Nuclear pores act as passage for proteins and RNA molecules in both the directions between nucleus and cytoplasm.

Correct Answer:

Mature sieve tube elements possess a conspicuous nucleus and usual cytoplasmic organelles.

Solution:

Mature sieve tube elements do not have nucleus but have cytoplasm known as **anucleated** living cells.

Q. 10 The first stable product of CO₂ fixation in sorghum is:

Option 1:

Pyruvic acid

Option 2:

Oxaloacetic acid

Option 3:

Succinic acid

Option 4:

Phosphoglyceric acid

Correct Answer:

Oxaloacetic acid

Solution:

The first stable product of CO₂ fixation in sorghum is Oxaloacetic acid (OAA), as sorghum is a C₄ plant.

Q. 11 When gene targeting involves gene amplification is attempted in an individual's tissue to treat disease, it is known as:

Option 1:

Biopiracy

Option 2:

Gene therapy

Option 3:

Molecular diagnosis

Option 4:

Safety testing

Correct Answer:

Gene therapy

Solution:

In gene therapy technique the absent or faulty gene is replaced by a working gene, so that the body can make the correct enzyme or protein and consequently eliminate the root cause of the disease. The first clinical gene therapy was given in 1990 to a 4- year old girl with **adenosine deaminase (ADA) deficiency**.

Q. 12 Match List -I with List - II

List - I	List -II
(a) Protoplast fusion	(i) Totipotency
(b) Plant tissue culture	(ii) Pomato
(c) Meristem culture	(iii) Somaclones
(d) Micropropagation	(iv) Virus free plants

Choose the correct answer from the options given below:

Option 1:

(a) - (iii), (b) - (iv), (c) - (ii), (d) - (i)

Option 2:

(a) - (ii), (b) - (i) , (c) - (i), (d) - (iii)

Option 3:

(a) - (iii), (b) - (iv) , (c) - (i), (d) - (ii)

Option 4:

(a) - (iv), (b) - (iii) , (c) - (ii), (d) - (i)

Correct Answer:

(a) - (iii), (b) - (iv), (c) - (ii), (d) - (i)

Solution:

Somatic fusion, also called **protoplast fusion**, is a type of genetic modification in plants by which two distinct species of plants are fused together to form a new hybrid plant with the characteristics of both, a **somatic hybrid**.

Plant tissue culture is defined as culturing plant seeds, organs, explants, tissues, cells, or protoplasts on a chemically defined **synthetic nutrient media** under sterile and controlled conditions of light, temperature, and humidity.

Meristem culture is defined as the tissue culture technique, which uses apical meristem with 1-3 leaf primordia to prepare clones of a plant by the vegetative propagation. This technique primarily involves the isolation of meristem by applying a V-Shape cut in the stem.

Micropropagation is the clonal propagation of plants in closed vessels under aseptic conditions. Inside the vessels, the plants are grown on culture media that contain nutrients and growth regulators, and are described as in vitro, which means 'in glass'. In contrast, soil-grown plants are described as in vivo.

Totipotency is defined in Wikipedia as the ability of a single cell to divide and produce all the differentiated cells in an organism, including extraembryonic tissues. Totipotent cells formed during sexual and asexual reproduction include spores and zygotes.

The **pomato** is a grafted plant that is produced by grafting together a tomato plant and a potato plant, both of which are members of the **Solanum genus** in the **Solanaceae family**.

Somaclones are the plants that are produced through tissue culture and are genetically identical to the parent plant from which they are produced and cultured.

Q. 13 Which of the following stages of meiosis involves division of centromere?

Option 1:
Metaphase I

Option 2:

Metaphase II

Option 3:

Anaphase II

Option 4:

Telophase II

Correct Answer:

Anaphase II

Solution:

Anaphase II begins with simultaneous splitting of the centromere of each chromosome that allows them to move towards opposite poles of the cell.

Q. 14 Which of the following are not secondary metabolites in plants?

Option 1:

Morphine, codeine

Option 2:

Amino acids, glucose

Option 3:

Vinblastin, curcumin

Option 4:

Rubber, gums

Correct Answer:

Amino acids, glucose

Solution:

Amino acids and glucose are **primary metabolites** in plants.

Primary metabolites are compounds that are directly involved in the growth and development of a plant whereas secondary metabolites are compounds produced in other metabolic pathways that, although important, are not essential to the functioning of the plant.

Q. 15 Which of the following plants is monoecious?

Option 1:

Carica papaya

Option 2:

Chara

Option 3:

Marchantia polymorpha

Option 4:

Cycas circinalis

Correct Answer:

Chara

Solution:

Monoecious or homothallic condition in Chara (green algae) is used to denote upper oogonium and lower antheridium on the same plant.

Q. 16 Mutations in plant cells can be induced by:

Option 1:

Kinetin

Option 2:

Infrared rays

Option 3:

Gamma rays

Option 4:

Zeatin

Correct Answer:

Gamma rays

Solution:

Gamma rays are ionizing radiation and used in inducing mutations in seeds and other planting materials such as cuttings, pollen, or tissue-cultured calli.

Q. 17 During purification process for recombinant DNA technology, addition of chilled ethanol precipitates out:

Option 1:

RNA

Option 2:

DNA

Option 3:
Histones

Option 4:
Polysaccharides

Correct Answer:
DNA

Solution:

The purified DNA, after treatment with various enzymes, precipitates out after addition of chilled ethanol. This is viewed as a collection of fine threads in the suspension, and is easily collected. The process is known as **DNA spooling**.

Q. 18 Plants follow different pathways in response to environment or phases of life to form different kinds of structures. This ability is called:

Option 1:
Elasticity

Option 2:
Flexibility

Option 3:
Plasticity

Option 4:
Maturity

Correct Answer:
Plasticity

Solution:

Plant plasticity refers to a plant's ability to adapt to and cope with changes in its environment. In contrast to animals, which are able to actively move away to avoid challenges such as a predators or a changing climate, plants have acquired the ability to biosynthesize an unprecedented array of structurally complex bioactive natural compounds with specialized roles in order to cope with environmental challenges.

For example, **genetically identical water flea (Daphnia) clones can differ in their morphology depending on whether reared in the absence or presence of a potential predator.**

Q. 19 Which of the following is not an application of PCR (Polymearse Chain Reaction)?

Option 1:
Molecular diagnosis

Option 2:

Gene amplification

Option 3:

Purification of isolated protein

Option 4:

Detection of gene mutation

Correct Answer:

Purification of isolated protein

Solution:

Some of the **areas of application of PCR** are mentioned here:

- (i) Diagnosis of pathogens.
- (ii) Diagnosis of specific mutation.
- (iii) DNA fingerprinting.
- (iv) Detection of specific microorganisms.
- (v) In prenatal diagnosis.
- (vi) Diagnosis of plant pathogens.
- (vii) In palaeontology.

Q. 20 The amount of nutrients, such as carbon, nitrogen, phosphorus and calcium present in the soil at any given time, is referred as:

Option 1:

Climax

Option 2:

Climax community

Option 3:

Standing state

Option 4:

Standing crop

Correct Answer:

Standing state

Solution:

Standing state is amount of inorganic nutrients found in an ecosystem. It represents part of non-living matter. It circulates between living and non-living components of the ecosystem. It is being regularly depleted and replenished by the living matters. Standing crop is amount of biomass present in an ecosystem.

Q. 21 The term used for transfer of pollen grains from anther of one plant to the stigma of a different plant which, brings genetically different types of pollen grains to stigma, is:

Option 1:
Xenogamy

Option 2:
Geitonogamy

Option 3:
Chasmogamy

Option 4:

Correct Answer:
Xenogamy

Solution:

Transfer of pollen grains from the anther to the stigma of same flower is known as **autogamy** or self pollination.

Geitonogamy is transfer of pollens from anther of one flower to stigma of another flower of the same plant

Xenogamy is the transfer of pollen grains from the anther to the stigma of a different plant.

Q. 22 The production of gametes by the parents, formation of zygotes, the F_1 and F_2 plants, can be understood from a diagram is called:

Option 1:
Bullet square

Option 2:
Punch square

Option 3:
Punnett square

Option 4:
Net square

Correct Answer:
Punnett square

Solution:

The Punnett square is a square diagram that is used to predict the genotypes of a particular cross or breeding experiment. It is named after **Reginald C. Punnett**, who devised the approach in 1905. The diagram is used by biologists to determine the probability of an offspring having a particular genotype.

Q. 23 In the equation $GPP - R = NPP$

R represents:

Option 1:
Radiant energy

Option 2:
Retardation factor

Option 3:
Environment factor

Option 4:
Respiration losses

Correct Answer:
Respiration losses

Solution:

GPP is gross primary productivity that is the rate of total production of biomass by producers.

R is the respiratory loss. A part of biomass produced by the plant utilized by them for their respiration.

NPP is the balance of biomass or energy remaining after meeting the cost of respiration of producers.

Q. 24 DNA strands on a gel stained with ethidium bromide when viewed under UV radiation, appear as:

Option 1:
Yellow bands

Option 2:
Bright orange bands

Option 3:

Dark red bands

Option 4:

Bright blue bands

Correct Answer:

Bright orange bands

Solution:

DNA strands on a gel stained with ethidium bromide when viewed under UV radiation, appear as **Bright orange bands** as EtBr absorbs UV radiations at **210-285nm** wavelength and get excited at **605 nm** due to which it fluoresces orange colour.

Q. 25 The factor that leads to founder effect in a population is:

Option 1:

Natural selection

Option 2:

Genetic recombination

Option 3:

Mutation

Option 4:

Genetic drift

Correct Answer:

Genetic drift

Solution:

Founder effect and bottleneck effect are two kinds of Genetic drift.

Q. 26 When the centromere is situated in the middle of two equal arms of chromosomes, the chromosome is referred as:

Option 1:

Metacentric

Option 2:

Telocentric

Option 3:

Sub - metacentric

Option 4:
Acrocentric

Correct Answer:
Metacentric

Solution:

On the basis of the location of the centromere, chromosomes are classified into four types: **metacentric**, **submetacentric**, **acrocentric**, and **telocentric**.

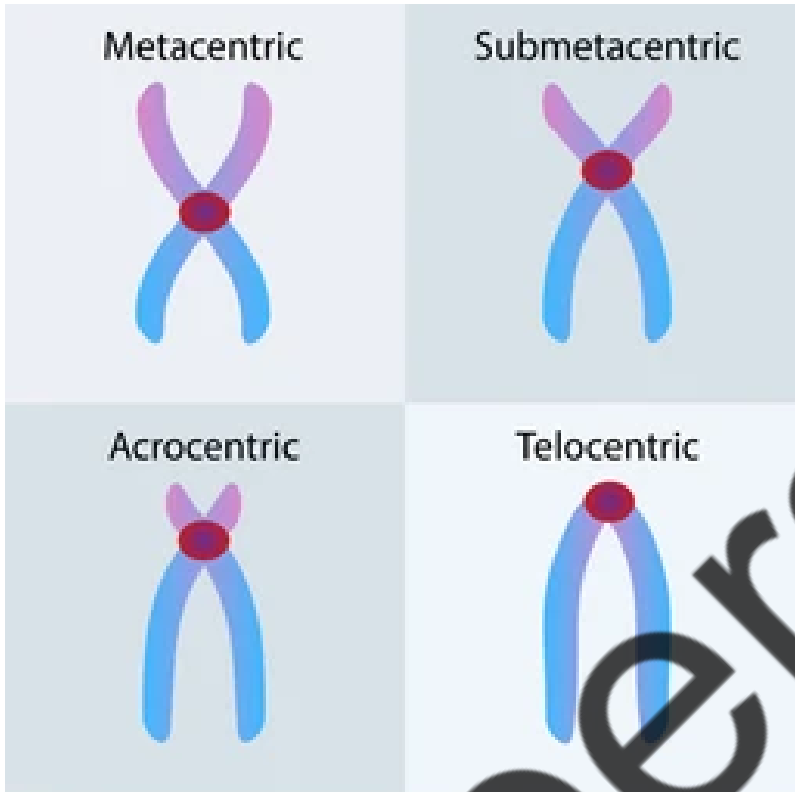

Q. 27 Genera like *Selaginella* and *Salvinia* produce two kinds of spores. Such plants are known as:

Option 1:
Homosorus

Option 2:
Heterosorus

Option 3:
Homosporous

Option 4:
Heterosporous

Correct Answer:
Heterosporous

Solution:

Heterospory is the production of spores of two different sizes and sexes by the sporophytes of land plants. The smaller of these, the microspore, is male and the larger megaspore is female.

Q. 28 Match List - I with List - II

List - I	List - II
(a) Cohesion	(i) More attraction in liquid plants
(b) Adhesion	(ii) Mutual attraction among water molecules
(c) Surface tension	(iii) Water loss in liquid phase
(d) Guttation	(iv) Attraction towards polar surfaces

Choose the correct answer from the options given below:

Option 1:

(a) - (ii), (b) - (iv), (c) - (i), (d) - (iii)

Option 2:

(a) - (iv), (b) - (iii), (c) - (ii), (d) - (i)

Option 3:

(a) - (iii), (b) - (i), (c) - (iv), (d) - (ii)

Option 4:

(a) - (ii), (b) - (i), (c) - (iv), (d) - (iii)

Correct Answer:

(a) - (ii), (b) - (iv), (c) - (i), (d) - (iii)

Solution:

Cohesion, adhesion and surface tension are important properties of water as they help the water from a tree's roots to be transported all the way to its leaves.

Cohesion holds hydrogen bonds together to create **surface tension** on water. Since water is attracted to other molecules, **adhesive forces** pull the water toward other molecules.

Q. 29 Gemmae are present in:

Option 1:

Liverworts

Option 2:

Brown algae

Option 3:
Red algae

Option 4:
Blue - green algae

Correct Answer:
Liverworts

Solution:

Most **liverworts** can reproduce asexually by means of **gemmae**, which are disks of tissues produced by the gametophytic generation. The gemmae are held in special organs known as **gemma cups** and are dispersed by rainfall.

Q. 30 Which of the following algae produces Carrageenan ?

Option 1:
Green algae

Option 2:
Brown algae

Option 3:
Red algae

Option 4:
Blue - green algae

Correct Answer:
Red algae

Solution:

Carrageenan is a **phycocolloids** produce in **red algae (Rhodophyceae)**. It is used as a clearing agent in liquors, leather finishing and as a emulsifier in chocolates, ice-creams, toothpastes, paints etc.

Q. 31 Complete the flow chart on central dogma.

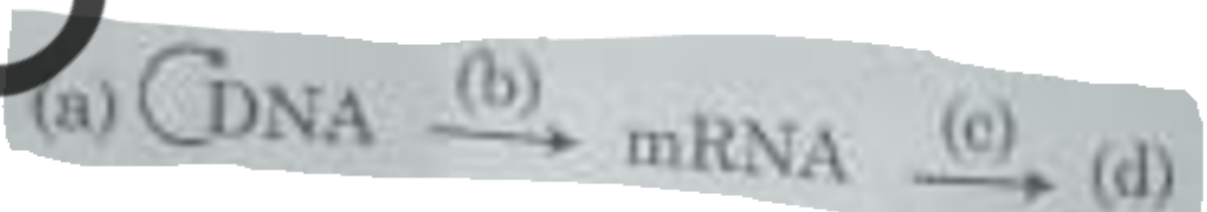

Option 1:
(a) - Replication ; (b) - Transcription; (c) - Transduction; (d) - Protein

Option 2:

(a) -Translation; (b) - Replication ; (c) - Transcription ; (d) - Transduction

Option 3:

(a) -Replication; (b) - Transcription ; (c) - Translation ; (d) - Protein

Option 4:

(a) -Transduction ; (b) - Translation ; (c) - Replication ; (d) - Protein

Correct Answer:

(a) -Replication; (b) - Transcription ; (c) - Translation ; (d) - Protein

Solution:

The central dogma of molecular biology is **an explanation of the flow of genetic information within a biological system**. It is often stated as "DNA makes RNA, and RNA makes protein".

It was first stated by **Francis Crick** in 1957, then published in 1958.

Q. 32 Which of the following statements is not correct?

Option 1:

Pyramid of biomass in sea is generally inverted.

Option 2:

Pyramid of biomass in sea is generally upright.

Option 3:

Pyramid of energy is always upright.

Option 4:

Pyramid of numbers in a grassland ecosystem is upright.

Correct Answer:

Pyramid of biomass in sea is generally upright.

Solution:

The pyramid of biomass in the sea is inverted because **the amount of biomass is least at the base of the pyramid and the amount of biomass is maximum at the apex of the pyramid**.

Eg: Biomass of zooplanktons is higher than that of phytoplanktons as life span of former is longer and the latter multiply much faster though having shorter life span. A number of generations of phytoplanktons may thus be consumed by single generation of zooplanktons.

Q. 33 In spite of interspecific competition in nature, which mechanism the competing species might have evolved for their survival?

Option 1:

Resource partitioning

Option 2:

Competitive release

Option 3:

Mutualism

Option 4:

Predation

Correct Answer:

Resource partitioning

Solution:

Resource partitioning or niche differentiation (**a process of natural selection that will force competitors to use resources differently**) is a way to avoid competition between species and allow for coexistence.

Species might evolve mechanism to live in the same niche by changing the **feeding time** or **foraging patterns**.

Q. 34 Match List -I with List -II

List - I	List - II
(a) Lenticels	(i) Phellogen
(b) Cork cambium	(ii) Suberin deposition
(c) Secondary cortex	(iii) Exchange of gases
(d) Cork	(iv) Phelloderm

Choose the correct answer from the options given below:

Option 1:

(a) - (iv), (b) - (i), (c) - (iii), (d) - (ii)

Option 2:

(a) - (iii), (b) - (i), (c) - (iv), (d) - (ii)

Option 3:

(a) - (ii), (b) - (iii), (c) - (iv), (d) - (i)

Option 4:

(a) - (iv), (b) - (ii), (c) - (i), (d) - (iii)

Correct Answer:

(a) - (iii), (b) - (i), (c) - (iv), (d) - (ii)

Solution:

Lenticels: In cork layer the lenticels are present which are meant for gaseous exchange. In cork, lenticels have loosely aggranged cells called **complementary cells** with intercellular spaces.

Cork cambium is a tissue found in many vascular plants as a part of the epidermis. It is one of the many layers of bark, between the cork and primary phloem. The cork cambium is a lateral meristem and is responsible for secondary growth that replaces the epidermis in roots and stems.

Secondary cortex is also known as **phelloderm**, produces from cork cambium on innerside of stem. Cells of phelloderm are thin walled, living and store food.

Cork also known as **phellem** produces from cork cambium on the outside of the stem. The cells of phellem are dead, suberized and impervious to water.

Cork (phellem) + Cork cambium (phellogen) + Secondary cortex (Phelloderm)= Periderm.

Q. 35 Match the List - I and List -II

List - I	List - II
(a) Cells with active cell division capacity	(i) Vascular tissue
(b) Tissue having all cells similar in structure and function	(ii) Meristematic tissue
(c) Tissue having different types of cells	(iii) Sclereids
(d) Dead cells with highly thickened walls and narrow lumen	(iv) Simple tissue

Select the correct answer from the options given below:

Option 1:

(a) - (ii), (b) - (iv), (c) - (i), (d) - (iii)

Option 2:

(a) - (iv), (b) - (iii), (c) - (iii), (d) - (i)

Option 3:

(a) - (i), (b) - (ii), (c) - (iii), (d) - (iv)

Option 4:

(a) - (iii), (b) - (ii), (c) - (iv), (d) - (i)

Correct Answer:

(a) - (ii), (b) - (iv), (c) - (i), (d) - (iii)

Solution:

Cells with active cell division capacity- **Meristematic tissue**

Tissue having all cells similar in structure and function- **Simple tissue**

Tissue having different types of cells- **Vascular tissue**

Dead cells with highly thickened walls and narrow lumen- **Sclereids**

Q. 36 Match Column - I with Column - II

Column - I	Column - II
(a) Nitrococcus	(i) Denitrification
(b) Rhizobium	(ii) Conversion of ammonia to nitrite
(c) Thiobacillus	(iii) Conversion of nitrite to nitrate
(d) Nitrobacter	(iv) Conversion of atmospheric nitrogen to ammonia

Choose the correct answer from options given below:

Option 1:

(a) - (ii), (b) - (iv), (c) - (i), (d) - (iii)

Option 2:

(a) - (i), (b) - (ii), (c) - (iii), (d) - (iv)

Option 3:

(a) - (iii), (b) - (i), (c) - (iv), (d) - (ii)

Option 4:

(a) - (iv), (b) - (iii), (c) - (ii), (d) - (i)

Correct Answer:

(a) - (ii), (b) - (iv), (c) - (i), (d) - (iii)

Solution:

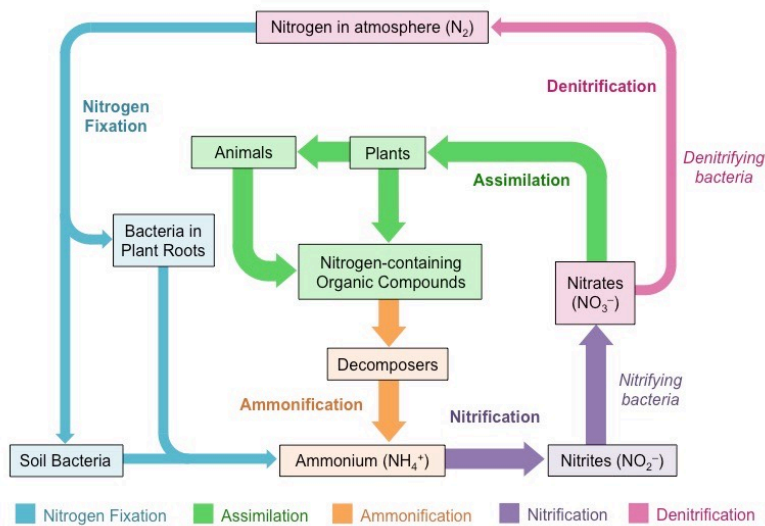

Q. 37 Match List - I with List - II

List - I	List - II
(a) S phase	(i) Proteins and synthesized
(b) G_2 phase	(ii) Inactive phase
(c) Quiescent stage	(iii) Interval between mitosis and initiation of DNA replication
(d) G_1 phase	(iv) DNA replication

Choose the correct answer from the option given below:

Option 1:

(a) - (iii), (b) - (ii), (c) - (i), (d) - (iv)

Option 2:

(a) - (iv), (b) - (ii), (c) - (iii), (d) - (i)

Option 3:

(a) - (iv), (b) - (i), (c) - (ii), (d) - (iii)

Option 4:

(a) - (ii), (b) - (iv), (c) - (iii), (d) - (i)

Correct Answer:

(a) - (iv), (b) - (i), (c) - (ii), (d) - (iii)

Solution:

Cell Cycle

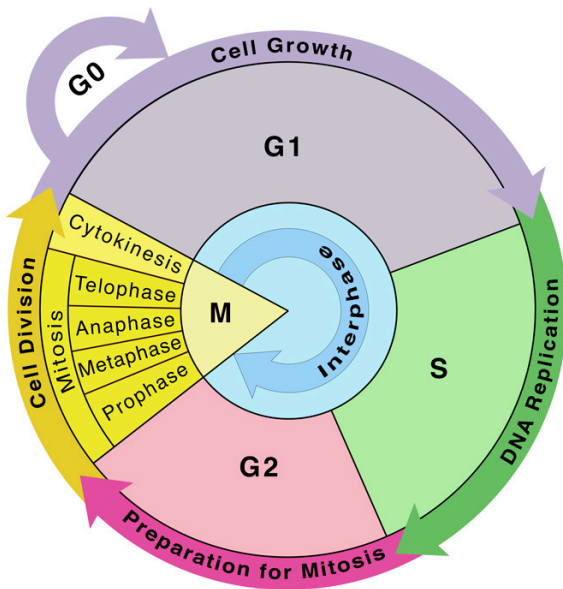

Q. 38 Match Column I with Column -II

Column - I	Column -II
(a)	(i) Brassicaceae
(b)	(ii) Liliaceae
(c)	(iii) Fabaceae
(d)	(iv) Solanaceae

Select the correct answer from the options given below:

Option 1:

(a) - (iii) , (b) - (iv), (c)- (ii), (d) - (i)

Option 2:

(a) - (i) , (b) - (ii), (c)- (iii), (d) - (iv)

Option 3:

(a) - (ii) , (b) - (iii), (c)- (iv), (d) - (i)

Option 4:

(a) - (iv) , (b) - (ii), (c)- (i), (d) - (iii)

Correct Answer:

(a) - (iii) , (b) - (iv), (c)- (ii), (d) - (i)

Solution:

A Floral formula is **a notation for representing the structure of particular types of flowers**. Such notations use numbers, letters and various symbols to convey significant information in a compact form.

Q. 39 Which of the following statements is incorrect?

Option 1:

During aerobic respiration, role of oxygen is limited to the terminal stage.

Option 2:

In ETC (Electron Transport Chain), one molecule of $\text{NADH} + \text{H}^+$ gives rise to 2 ATP molecules, and FADH_2 gives rise to 3 ATP molecules.

Option 3:

ATP is synthesized through complex V.

Option 4:

Oxidation - reduction reactions produces proton gradient in respiration.

Correct Answer:

In ETC (Electron Transport Chain), one molecule of $\text{NADH} + \text{H}^+$ gives rise to 2 ATP molecules, and FADH_2 gives rise to 3 ATP molecules.

Solution:

Oxidation of one molecule of NADH gives rise to 3 molecules of ATP while that of one molecule of FADH_2 produces 2 molecules of ATP.

Q. 40 In the exponential growth equation

$$N_t = N_0 e^{rt}$$

represents:

Option 1:

The base number logarithms

Option 2:

The base of exponential logarithms

Option 3:

The base of natural logarithms

Option 4:

The base of general logarithms

Correct Answer:

The base of natural logarithms

Solution:

The integral equation for exponential growth is $N_t = N_0 e^{rt}$. Where N_t = Population density after time t , N_0 = Population density at time zero, r = intrinsic rate of natural increase, e = the base of natural logarithms.

Q. 41 Which of the following statements is incorrect?

Option 1:

Both ATP and NADPH + H⁺ are synthesized during non-cyclic photophosphorylation

Option 2:

Stroma lamellae have PS I only and lack NADP reductase.

Option 3:

Grana lamellae have both PS I and PS II

Option 4:

Cyclic photophosphorylation involves both PS I and PS II

Correct Answer:

Cyclic photophosphorylation involves both PS I and PS II

Solution:

When only PS I is functional, the electron is circulated within the photosystem and the phosphorylation occurs, due to the cyclic flow of electrons. The membrane and lamella of the grana have both PS I and PS II, the stroma lamella membrane lack PS II as well as NADP reductase enzyme.

Q. 42 What is the role of RNA polymerase III in the process of transcription in eukaryotes?

Option 1:

Transcribe rRNAs (28S, 18S and 5.8S)

Option 2:

Transcribes tRNA, 5S rRNA and snRNA.

Option 3:

Transcribes precursor of mRNA

Option 4:

Transcribes only snRNAs

Correct Answer:

Transcribes tRNA, 5S rRNA and snRNA.

Solution:

In eukaryote cells, RNA polymerase III (also called Pol III) **transcribes DNA to synthesize ribosomal 5S rRNA, tRNA and other small RNAs**. The genes transcribed by RNA Pol III fall in the category of "housekeeping" genes whose expression is required in all cell types and most environmental conditions.

Q. 43 Now a days it is possible to detect the mutated gene causing cancer by allowing radioactive probe to hybridise its complementary DNA in a clone of cells, followed by its detection using autoradiography because:

Option 1:
mutated gene partially appears on a photographic film

Option 2:
mutated gene completely and clearly appears on photographic films

Option 3:
mutated gene does not appear on a photographic film as the probe has no complementary with it.

Option 4:
mutated gene does not appear on photographic film as the probe has complementary with it.

Correct Answer:

mutated gene does not appear on photographic film as the probe has complementary with it.

Solution:

A single-stranded DNA or RNA, tagged with a radioactive molecule (probe) is allowed to hybridise to its complementary DNA in a clone of cells followed by detection using autoradiography. The clone having the mutated gene will hence not appear on the photographic film, because the probe will not have complementarity with the mutated gene.

Q. 44 Which of the following statements is correct?

Option 1:
Fusion of two cells is called Karyogamy

Option 2:
Fusion of protoplasm between two motile on non -motile gametes is called plasogamy

Option 3:
Organism that depend on the living plants are called saprophytes.

Option 4:

Some of the organisms can fix atmospheric nitrogen in specialized cells called sheath cells.

Correct Answer:

Fusion of two cells is called Karyogamy

Solution:

Plasmogamy, **the fusion of two protoplasts (the contents of the two cells), brings together two compatible haploid nuclei.** At this point, two nuclear types are present in the same cell, but the nuclei have not yet fused.

Some of the organisms like **Nostoc and Anabaena** can fix atmospheric nitrogen in specialized cells called **Heterocyst.**

Q. 45 Match List - I with List - II

List - I	List - II
(a) Protein	(i) C = C double bond
(b) Unsaturated fatty acid	(ii) Phosphodiester bonds
(c) Nucleic acid	(iii) Glycosidic bonds
(d) Polysaccharide	(iv) Peptide bond

Choose the correct answer from the options given below:

Option 1:

a - iv, b - i, c - ii, d - iii

Option 2:

a - i, b - iv, c - iii, d - ii

Option 3:

a - ii, b - i, c - iv, d - iii

Option 4:

a - iv, b - iii, c - i, d - ii

Correct Answer:

a - iv, b - i, c - ii, d - iii

Solution:

Protein- peptide bond: A **covalent bond** joining the α -amino group of one amino acid to the carboxyl group of another with the loss of a water molecule.

Unsaturated fatty acid- C=C double bond

Nucleic acid- Phosphodiester bonds: A phosphodiester bond occurs when exactly two of the hydroxyl groups in phosphoric acid react with hydroxyl groups on other molecules to form two ester bonds.

Polysaccharide - Glycosidic bonds: glycosidic bond or glycosidic linkage is a type of covalent bond that joins a carbohydrate molecule to another group, which may or may not be another carbohydrate.

Q. 46 Select the correct pair

Option 1:

Large colorless empty cells in the epidermis of grass leaves - Subsidiary leaves

Option 2:

In dicot leaves, vascular bundles are surrounded by large thick walled cells - Conjunctive tissue

Option 3:

Cells of medullary rays that form part of cambial ring - Interfascicular cambium

Option 4:

Loose parenchyma cells rupturing epidermis and forming a lens-shaped opening in bark - Spongy parenchyma

Correct Answer:

Cells of medullary rays that form part of cambial ring - Interfascicular cambium

Solution:

Large colorless with thin flexible walls, empty cells in the epidermis of some grasses like Poa, Aropyron, Maize etc., epidermal cells are known as **Bulliform or motor cells**. These cells help in rolling and unrolling of leaves.

In dicot leaves, vascular bundles are surrounded by large thick walled cells known as **bundle sheath cells**.

Loose parenchyma cells rupturing epidermis and forming a lens-shaped opening in bark are called **lenticels**, which are meant for gaseous exchange.

Q. 47 DNA fingerprinting involves identifying differences in some specific regions in DNA sequence, called as:

Option 1:

Satellite DNA

Option 2:

Repetitive DNA

Option 3:

Single nucleotides

Option 4:

Polymorphic DNA

Correct Answer:

Repetitive DNA

Solution:

Repetitive DNA: Stretches of DNA that repeat themselves throughout a genome, either in tandem or interspersed along the genome. These stretches can comprise up to fifty percent or more of an organism's DNA. Hence, the correct option is (b).

Q. 48 Plasmid pBR322 has PstI restriction enzyme site within gene amp^R that confers ampicillin resistance. If this enzyme is used for inserting a gene β -galactoside production and the recombinant plasmid is inserted in an *E. coli* strain

Option 1:

it will not be able to confer ampicillin resistance to the host cell

Option 2:

the transformed cells will have the ability to resist ampicillin as well as produce β -galactoside

Option 3:

it will lead to lysis of host cell

Option 4:

it will be able to produce a novel protein with dual ability

Correct Answer:

it will not be able to confer ampicillin resistance to the host cell

Solution:

Since the gene is inserted at Pst I of amp^R region of pBR322, the amp^R gene is inactivated which is called as **insertional inactivation**. Hence the genetically modified *E. coli* strain will not be able to confer ampicillin resistance.

Q. 49 Identify the correct statement:

Option 1:

In capping, methyl guanosine triphosphate is added to the 3' end of hnRNA

Option 2:

RNA polymerase binds with Rho factor to terminate the process of transcription in bacteria.

Option 3:

The coding strand in a transcription unit is copied to an mRNA

Option 4:

Split gene arrangement is characteristic of prokaryotes.

Correct Answer:

RNA polymerase binds with Rho factor to terminate the process of transcription in bacteria.

Solution:

In the cell, Rho binds to untranslated naked RNAs and terminates the synthesis of mRNA at the end of a significant number of operons.

Q. 50 In some members of which of the following pairs of families, pollen grains retain their viability for months after release?

Option 1:

Poaceae: Rosaceae

Option 2:

Poaceae: Leguminosae

Option 3:

Poaceae: Solanaceae

Option 4:

Rosaceae : Leguminosae

Correct Answer:

Rosaceae : Leguminosae

Solution:

In dicot families like **Solanaceae, Rosaceae and Leguminosae** the viability of pollen grains remain months together after their release.

Q. 51 Which of the following characteristics is incorrect with respect to cockroach ?

Option 1:

A ring of gastric caeca is present at the junction of midgut and hind gut

Option 2:

Hypopharynx lies within the cavity enclosed by the mouth parts.

Option 3:

In females, 7th , 9th sterna together form a genital pouch

Option 4:

10th abdominal segment in both sexes, bears a pair of anal cerci.

Correct Answer:

A ring of gastric caeca is present at the junction of midgut and hind gut

Solution:

Correct option is (a)

-Hepatic Caecae is between foregut and midgut

- Malpighian tubules is between midgut and hindgut.

Q. 52 Match List - I with List - II.

List - I		List - II	
(a)	Metamerism	(i)	Coelenterata
(b)	Canal system	(ii)	Ctenophora
(c)	Comb plates	(iii)	Annelida
(d)	Cnidoblasts	(iv)	Porifera

Choose the correct answer from the option given below.

Option 1:

(a) (b) (c) (d)
(iv) (iii) (i) (ii)

Option 2:

(a) (b) (c) (d)
(iii) (iv) (i) (ii)

Option 3:

(a) (b) (c) (d)
(iii) (iv) (ii) (i)

Option 4:

(a) (b) (c) (d)

(iv) (i) (ii) (iii)

Correct Answer:

(a) (b) (c) (d)

(iii) (iv) (ii) (i)

Solution:

Correct option is (c)

Metamerism - Segmented body(Annelids)

Canal System - Porifera (Sponges)

Combi plates - Ctenophora

Cnidoblasts - Coelentetrata (Cnidoblasts)

Q. 53 A specific recognition sequence identified by endonucleases to make cuts at specific positions within the DNA is :

Option 1:

Degenerate primer sequence

Option 2:

Okazaki sequences

Option 3:

Palindromic Nucleotide sequences

Option 4:

Poly (A) tail sequences

Correct Answer:

Palindromic Nucleotide sequences

Solution:

Palindrome sequence reads same from both the directions. It is specific recognition sequence identified by endonucleases to cut the DNA strands at the specific positions.

Q. 54 The fruit fly has 8 chromosomes ($2n$) in each cell. During interphase of Mitosis if the number of chromosomes at G_1 phase is 8, what would be the number of chromosomes after S phase ?

Option 1:

8

Option 2:

16

Option 3:

4

Option 4:

32

Correct Answer:

8

Solution:

Correct option is (a)

It will be same as that of G1, hence answer is 8.

Q. 55 Persons with 'AB' blood group are called as "Universal recipients". This is due to :

Option 1:

Absence of antigens A and B on the surface of RBCs

Option 2:

Absence of antigens A and B in plasma

Option 3:

Presence of antibodies, anti- A and anti- B on RBCs

Option 4:

Absence of antibodies, anti-A and anti- B, in plasma

Correct Answer:

Absence of antibodies, anti-A and anti- B, in plasma

Solution:

Correct option is (d)

ABO blood group is on the basis of Antigens present on the RBC surface.

It is either A blood group B, O or AB

AB blood group is due to the presence of two antigens A. Due to this no antibodies are present.

Q. 56 Which of the following statements wrongly represents the nature of smooth muscle?

Option 1:

These muscle have no striations

Option 2:

They are involuntry muscles

Option 3:

Communication among the cells is performed by intercalated discs

Option 4:

These muscles are present in the wall of blood vessels

Correct Answer:

Communication among the cells is performed by intercalated discs

Solution:

Correct option is (c)

Intercalated discs are feature of cardiac muscles only.

Q. 57 Which one of the following belongs to the family Muscidae?

Option 1:

Fire fly

Option 2:

Grasshopper

Option 3:

Crockroach

Option 4:

House fly

Correct Answer:

House fly

Solution:

Correct option is (d)

Q. 58 Which is the "Only enzyme" that has "Capability" to catalyse Initiation, Elongation and Termination in the process of transcription in prokaryotes ?

Option 1:

DNA dependnet DNA polymerase

Option 2:

DNA dependent RNA polymerase

Option 3:

DNA Ligase

Option 4:

DNase

Correct Answer:

DNA dependent RNA polymerase

Solution:

- In the process of transcription in prokaryotes, DNA-dependent RNA polymerase is the enzyme responsible for catalyzing initiation, elongation, and termination. It binds to the DNA template and synthesizes an RNA molecule complementary to the DNA strand, resulting in the production of RNA transcripts. Therefore, **option 2 is the correct answer.**
- Option 1 is incorrect because DNA-dependent DNA polymerase is involved in DNA replication.
- Option 3 is incorrect DNA ligase joins DNA fragments together
- Option 4 is incorrect DNase degrades DNA.

Q. 59 Which of the following RNAs is not required for the synthesis of protein ?

Option 1:

mRNA

Option 2:

tRNA

Option 3:

rRNA

Option 4:

aiRNA

Correct Answer:

aiRNA

Solution:

Correct option is (d)

mRNA for transcription tRNA and rRNA for translation.

Q. 60 For effective treatment of the disease, early diagnosis and understanding its pathophysiology is very important. Which of the following molecular diagnostic techniques is very useful for early detection?

Option 1:

Western Blotting Technique

Option 2:

Southern Blotting Technique

Option 3:

ELISA Technique

Option 4:

Hybridization Technique

Correct Answer:

ELISA Technique

Solution:

Correct option is (b)

Southern Blotting Technique

Q. 61 Erythropoietin hormone which stimulates R.B.C.formation is produced by :

Option 1:

Alpha cells of pancreas

Option 2:

The cells of rostral adenohypophysis

Option 3:

The cells of bone marrow

Option 4:

cells of the kidney

Correct Answer:

cells of the kidney

Solution:

Correct option is (d)

Erythropoietin helps in the process of Erythropoiesis.

Q. 62 The partial pressures (in mm Hg) of oxygen (O_2) and carbon dioxide (CO_2) at alveoli (the site of diffusion) are :

Option 1:

$pO_2 = 104$ and $pCO_2 = 40$

Option 2:

$pO_2 = 40$ and $pCO_2 = 45$

Option 3:

$pO_2 = 95$ and $pCO_2 = 40$

Option 4:

$pO_2 = 160$ and $pCO_2 = 80$

Correct Answer:

$pO_2 = 104$ and $pCO_2 = 40$

Solution:

Correct option is (a)

$pO_2 = 104$ and $pCO_2 = 40$

Q. 63 In a cross between a male and female, both heterozygous for sickle cell anaemia gene, what percentage of the progeny will be diseased ?

Option 1:

50%

Option 2:
75%

Option 3:
25%

Option 4:
100%

Correct Answer:
25%

Solution:
Correct option is (c)

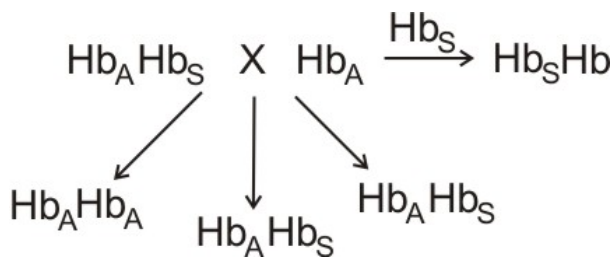

Sickle cell is Autosomal recessive. Only 25% of progeny is affected.

Q. 64 Which stage of meiotic prophase shows terminalisation of chiasmata as its distinctive feature?

Option 1:
Leptotene

Option 2:
Zygotene

Option 3:
Diakinesis

Option 4:
Pachytene

Correct Answer:
Diakinesis

Solution:
Correct option is (c)

Terminalisation of Chiasmata is a feature of Diakeneses.

Q. 65 Which one of the following organisms bear hollow and pneumatic long bones ?

Option 1:

Neophron

Option 2:

Hemidactylus

Option 3:

Macropus

Option 4:

Ornithorhynchus

Correct Answer:

Neophron

Solution:

Correct option is (a)

This is a feature of Class Aves.(birds)

Neophron is Vulture

Q. 66 Match the following :

List - I		List - II	
(a)	Physalia	(i)	Pearl oyster
(b)	Limulus	(ii)	Portuguese Man of War
(c)	Ancylostoma	(iii)	Living fossil
(d)	Pinctada	(iv)	Hookworm

Choose the correct answer from the options given below.

Option 1:

(a) (b) (c) (d)

(ii) (iii) (i) (iv)

Option 2:

(a) (b) (c) (d)

(iv) (i) (iii) (ii)

Option 3:

(a) (b) (c) (d)

(ii) (iii) (iv) (i)

Option 4:

(a) (b) (c) (d)

(i) (iv) (iii) (ii)

Correct Answer:

(a) (b) (c) (d)

(ii) (iii) (iv) (i)

Solution:

Correct option is (c)

Physalia - Portuguese Man of War

Limulus - Living fossil

Ancylostoma - Hookworm

Pinctada - Pearl oyster

Q. 67 Which of the following is not an objective of Biofortification in crops ?

Option 1:

Improve protein content

Option 2:

Improve resistance to diseases

Option 3:

Improve vitamin content

Option 4:

and mineral content

Correct Answer:

Improve resistance to diseases

Solution:

Improving resistance to disease in crop is not an objective of Biofortification of crops.

Hence, the correct option is (b).

Q. 68 If Adenine makes 30% of the DNA molecule, what will be the percentage of Thymine, Guanine, and Cytosine in it?

Option 1:

$T : 20 : G : 30 : C : 20$

Option 2:

$T : 20 : G : 20 : C : 30$

Option 3:

$T : 30 : G : 20 : C : 20$

Option 4:

$T : 20 : G : 25 : C : 25$

Correct Answer:

$T : 30 : G : 20 : C : 20$

Solution:

The correct option is (c)

$$A = T \text{ hence } T = 30\%$$

$$A + T = 60\%$$

$$G + C = 100 - 60 = 40$$

$$\therefore G = C = 20\%$$

Q. 69 Match **List-I** with **List - II**.

List - I		List - II	
(a)	Vaults	(i)	Entry of sperm through the Cervix is blocked
(b)	IUDs	(ii)	Removal of Vas deferens
(c)	Vasectomy	(iii)	Phagocytosis of sperms within the Uterus
(d)	Tubectomy	(iv)	Removal of the fallopian tube

Choose the correct answer from the options given below.

Option 1:

(a) (b) (c) (d)
(iv) (ii) (i) (iii)

Option 2:

(a) (b) (c) (d)
(i) (iii) (ii) (iv)

Option 3:

(a) (b) (c) (d)
(ii) (iv) (iii) (i)

Option 4:

(a) (b) (c) (d)
(iii) (i) (iv) (ii)

Correct Answer:

(a) (b) (c) (d)
(i) (iii) (ii) (iv)

Solution:

Correct option is (b)

Vaults - Entry of sperm through Cervix is blocked

IUDs - Phagocytosis of sperms within the Uterus

Vasectomy - Removal of Vas deferens

Tubectomy - Removal of fallopian tube

Q. 70 Veneral diseases can spread through:

- (a) Using sterile needles
- (b) Transfusion of blood from infected person
- (c) Infected mother of foetus
- (d) Kissing
- (e) Inheritance

Choose the correct answer from the options given below.

Option 1:

(a), (b) and (c) only

Option 2:

(b), (c) and (d) only

Option 3:

(b) and (c) only

Option 4:

(a) and (c) only

Correct Answer:

(b) and (c) only

Solution:

Veneral diseases are STD's. Hence, the Correct option is (c)

Q. 71 The centriole undergoes duplication during :

Option 1:

S- phase

Option 2:

Prophase

Option 3:

Metaphase

Option 4:
G₂ Phase

Correct Answer:
S- phase

Solution:

Correct option is (a)

Centriole duplicates during S Phase

Q. 72 Receptors for sperm binding in mammals are present on :

Option 1:
Corona radiate

Option 2:
Vitelline membrane

Option 3:
Perovitellic space

Option 4:
Zona pellucida

Correct Answer:
Zona pellucida

Solution:

Correct option is (d)

Zp (2) and ZP (3) are the receptors on Zona.

Q. 73 Dobson units are used to measure thickness of :

Option 1:
CFCs

Option 2:
Stratosphere

Option 3:
Ozone

Option 4:
Troposphere

Correct Answer:
Troposphere

Solution:
Correct option is (d)

Troposphere is a part of Ozone

Q. 74 Match **List -I** with **List - II**.

List - I		List - II	
(a)	Aspergillus niger	(i)	Acetic Acid
(b)	Acetobacter aceti	(ii)	Lactic Acid
(c)	Clostridium butylicum	(iii)	Citric Acid
(d)	Lactobacillus	(iv)	Butyric Acid

Choose the correct answer from the options given below.

Option 1:
(a) (b) (c) (d)
(iii) (i) (iv) (ii)

Option 2:
(a) (b) (c) (d)
(i) (ii) (iii) (iv)

Option 3:
(a) (b) (c) (d)
(ii) (iii) (i) (iv)

Option 4:
(a) (b) (c) (d)
(iv) (ii) (i) (iii)

Correct Answer:

(a) (b) (c) (d)

(iii) (i) (iv) (ii)

Solution:

Correct option is (a)

Aspergillus niger	(iii)	Citric Acid
Acetobacter aceti	(i)	Acetic Acid
Clostridium butylicum	(iv)	Butyric Acid
Lactobacillus	(ii)	Lactic Acid

Q. 75 Identify the **incorrect** pair.

Option 1:

Alkaloids - Codeine

Option 2:

Toxin - Abrin

Option 3:

Lectins - Concanavalin A

Option 4:

Drugs - Ricin

Correct Answer:

Drugs - Ricin

Solution:

Correct option is (d)

Ricin is s toxin

Q. 76 The organelles that are included in the endomembrane system are :

Option 1:

Endoplasmic reticulum, Mitochondria, Ribosomes and Lysosomes

Option 2:

Endoplasmic reticulum, Golgi complex, Lysosomes and Vacuoles

Option 3:

Golgi complex, Mitochondria, Ribosomes and Lysosomes

Option 4:

Golgi complex, Endoplasmic reticulum, Mitochondria and Lysosomes

Correct Answer:

Endoplasmic reticulum, Golgi complex, Lysosomes and Vacuoles

Solution:

Correct option is (b)

Endoplasmic reticulum, Golgi complex, Lysosomes and Vacuoles

Q. 77 Chronic auto immune disorder affecting neuro muscular junction leading to fatigue, weakening and paralysis of skeletal muscle is called as :

Option 1:

Arthritis

Option 2:

Muscular dystrophy

Option 3:

Myasthenia gravis

Option 4:

Gout

Correct Answer:

Myasthenia gravis

Solution:

Correct option is (c)

Myasthenia gravis

Q. 78 With regard to insulin choose correct options.

- (a) C-peptide is not present in mature insulin.
- (b) The insulin produced by rDNA technology has C-peptide.
- (c) The pro-insulin has C-peptide
- (d) A-peptide and B-peptide of insulin are interconnected by disulphide bridges.

Choose the **correct** answer from the options given below.

Option 1:

(b) and (d) only

Option 2:

(b) and (c) only

Option 3:

(a), (c) and (d) only

Option 4:

(a) and (d) only

Correct Answer:

(a), (c) and (d) only

Solution:

Correct option is (c)

- (a) C-peptide is not present in mature insulin.
- (c) The pro-insulin has C-peptide
- (d) A-peptide and B-peptide of insulin are interconnected by disulphide bridges.

Q. 79 During the process of gene amplification using PCR, if very high temperature is not maintained in the beginning, then which of the following steps of PCR will be affected first ?

Option 1:

Annealing

Option 2:
Extension

Option 3:
Denaturation

Option 4:
Ligation

Correct Answer:
Denaturation

Solution:
Correct option is (c)

Denaturation is the first step in PCR process

Q. 80 Which enzyme is responsible for the conversion of inactive fibrinogens to fibrins ?

Option 1:
Thrombin

Option 2:
Renin

Option 3:
Epinephrine

Option 4:
Thrombokinase

Correct Answer:
Thrombin

Solution:
Correct option is (a)

Thrombin

Q. 81 Succus entericus is referred to as :

Option 1:

Pancreatic juice

Option 2:

Intestinal juice

Option 3:

Gastric juice

Option 4:

Chyme

Correct Answer:

Intestinal juice

Solution:

Correct option is (b)

Intestinal juice

Q. 82 Select the favourable conditions required for the formation of oxyhaemoglobin at the alveoli.

Option 1:

High pO_2 , low pCO_2 , less H^+ , lower temperature

Option 2:

Low pO_2 , high pCO_2 , more H^+ , higher temperature

Option 3:

High pO_2 , high pCO_2 , less H^+ , higher temperature

Option 4:

Low pO_2 , low pCO_2 , more H^+ , higher temperature

Correct Answer:

High pO_2 , low pCO_2 , less H^+ , lower temperature

Solution:

Correct option is (a)

Oxyhaemoglobin is formed near alveoli. High pO_2 , low pCO_2 , low H^+ , high pH^+ . Low temperature are the conditions favourable for the same.

Q. 83 Which one of the following is an example of Hormone releasing IUD ?

Option 1:

CuT

Option 2:

LNG 20

Option 3:

Cu 7

Option 4:

Multiload 375

Correct Answer:

LNG 20

Solution:

Correct option is (b)

LNG 20 is hormone containing IUD

Q. 84 Sphincter of oddi is present at :

Option 1:

Ileo-Caecal junction

Option 2:

Junction of hepato-pancreatic duct and duodenum

Option 3:

Gastro-oesophageal junction

Option 4:

Junction of jejunum and duodenum

Correct Answer:

Junction of hepato-pancreatic duct and duodenum

Solution:

Correct option is (b)

Junction of hepato-pancreatic duct and duodenum.

Q. 85 Read the following statements:

- (a) Metagenesis is observed in Helminths
- (b) Echinoderms are triploblastic and coelomate animals
- (c) Round worms have organ-system level of body organization.
- (d) Comb plates present in ctenophores help in digestion.
- (e) water vascular system is characteristic of Echinoderms.

Choose the **correct** answer from the options given below.

Option 1:

(c),(d) and (e) are correct

Option 2:

(a),(b) and (c) are correct

Option 3:

(a),(d) and (e) are correct

Option 4:

(b), (c) and (e) are correct

Correct Answer:

(b), (c) and (e) are correct

Solution:

Correct option is (d)

(b) Echinoderms are triploblastic and coelomate animals

(c) Round worms have organ-system level of body organization.

(e) water vascular system is characteristic of Echinoderms.

Q. 86 Which of these is not an important component of initiation of parturition in humans?

Option 1:

Increases in estrogen and progesterone ratio

Option 2:

Synthesis of prostaglandins

Option 3:

Release of Oxytocin

Option 4:

Release of Prolactin

Correct Answer:

Increases in estrogen and progesterone ratio

Solution:

Correct option is (a)

Increases in estrogen and progesterone ratio is not an important factor for parturition.

Q. 87 During muscular contraction which of following event occur?

(a) 'H' zone disappears

(b) 'A' band widens

(c) 'I' band reduces in width

(d) Myosine hydrolyzes ATP, releasing the ADP___and Pi

(e) Z-lines attached to actins are pulled in

Choose the correct answer from the option given below.

Option 1:

(a),(c),(d),(e) only

Option 2:

(a),(b),(c),(d) only

Option 3:

(b),(c),(d),(e) only

Option 4:

(b),(d),(e),(a) only

Correct Answer:

(a),(c),(d),(e) only

Solution:

Correct option is (a)

(a) 'H' zone disappears

(c) 'I' band reduces in width

(d) Myosine hydrolyzes ATP, releasing the ADP and Pi

(e) Z-lines attached to actins are pulled in

Q. 88 Following are the statements with reference to 'lipids'.

(a) Lipids having only single bonds are called unsaturated fatty acids.

(b) Lecithin is a phospholipid.

(c) Trihydroxy propane is glycerol.

(d) Palmitic acid has 20 carbon atoms including carboxyl carbon.

(e) Arachidonic acid has 16 carbon atoms.

Choose the correct answer from the options given below.

Option 1:

(a) and (b) only

Option 2:

(c) and (d) only

Option 3:

(b) and (c) only

Option 4:

(b) and (e) only

Correct Answer:

(b) and (c) only

Solution:

- **Statement (b) is correct.** Lecithin is indeed a phospholipid.
- **Statement (c) is also correct.** Trihydroxy propane is another name for glycerol, which is a common component of lipids.
- Statements (a), (d), and (e) are incorrect:
- Statement (a) is incorrect. Lipids having only single bonds are called saturated fatty acids, not unsaturated fatty acids.
- Statement (d) is incorrect. Palmitic acid has 16 carbon atoms, not 20.
- Statement (e) is incorrect. Arachidonic acid has 20 carbon atoms, not 16.
- Therefore, the correct answer is option 3.

Q. 89 Which of the following is not a step in multiple Ovulation Embryo Transfer Technology (MOET)?

Option 1:

Cow is administered hormone having LH like activity for super ovulation

Option 2:

Cow yeilds about 6-8 eggs at a time

Option 3:

Cow is fertilized by artificial insemination

Option 4:

Fertilized eggs are transferred to surrogate mothers at 8-32 cell stage

Correct Answer:

Cow is administered hormone having LH like activity for super ovulation

Solution:

Correct option is (a)

In this method, cow is administered with FSH like hormone, **to induce follicular maturation** and then the super ovulation is brought about. In each cycle, 6–8 eggs mature simultaneously.

Q. 90 Identify the types of cell junctions that helps to stop the leakage of the substances across a tissue and facilitation of communication with neighbouring cells via rapid transfer of ions and molecules.

Option 1:

Gap junctions and Adhering junctions, respectively.

Option 2:

Tight junctions and Gap junctions, respectively.

Option 3:

Adhering junctions and Tight junctions, respectively.

Option 4:

Adhering junctions and Gap junctions, respectively.

Correct Answer:

Tight junctions and Gap junctions, respectively.

Solution:

Correct option is (b)

Tight Junctions → Brings about leakage of substances.

Gap Junctions → Communication between cytoplasm.

Q. 91 The Adenosine deaminase deficiency results into:

Option 1:

Dysfunction of Immune system

Option 2:

Parkinson's disease

Option 3:

Digestive disorder

Option 4:

Addison's disease

Correct Answer:

Dysfunction of Immune system

Solution:

Correct option is (a)

Dysfunction of Immune system

Q. 92 Statement I:

The codon 'AUG' codes for methionine and phenylalanine.

Statement II :

'AAA' and 'AAG' both codons code for the amino acid lysine.

In the light of the above statements, choose the **correct** answer from the options given below.

Option 1:

Both Statement I and Statement II are true

Option 2:

Both Statement I and Statement II are false

Option 3:

Statement I is correct but Statement II is false

Option 4:

Statement I is incorrect but Statement II is true.

Correct Answer:

Statement I is incorrect but Statement II is true.

Solution:

AUG codes for only methionine but not tryptophan. (A given codon codes for only one amino acid but not more than one amino acids.). AAG and AAA are the two codons for the amino acid Lysine.

Hence,Correct option is (d) - Statement I is incorrect but Statement II is true.

Q. 93 Match **List - I** with **List - II**.

List - I		List - II	
(a)	Scapula	(i)	Cartilaginous joints
(b)	Cranium	(ii)	Flat bone
(c)	Sternum	(iii)	Fibrous joints
(d)	Vertebral Column	(iv)	Triangular flat bone

Choose the **correct** answer from the options given below.

Option 1:

(a) (b) (c) (d)
(i) (iii) (ii) (iv)

Option 2:

(a) (b) (c) (d)
(ii) (iii) (iv) (i)

Option 3:

(a) (b) (c) (d)
(iv) (ii) (iii) (i)

Option 4:

(a) (b) (c) (d)
(iv) (iii) (ii) (i)

Correct Answer:

(a) (b) (c) (d)
(iv) (iii) (ii) (i)

Solution:

Correct option is (d)

Scapula - Triangular flat bone

Cranium - Fibrous joints

Sternum - Flat bone

Vertebral column - Cartilaginous joints

Q. 94 Match **List - I** with **List - II**.

List - I		List - II	
(a)	Filariasis	(i)	Haemophilus Influenzae
(b)	Amoebiasis	(ii)	Trichophyton
(c)	Pneumonia	(iii)	Wuchereria bancrofti
(d)	Ringworm	(iv)	Entamoeba Histolytica

Choose the correct answer from the options given below.

Option 1:

(a) (b) (c) (d)
(iv) (i) (iii) (ii)

Option 2:

(a) (b) (c) (d)
(iii) (iv) (i) (ii)

Option 3:

(a) (b) (c) (d)
(i) (ii) (iv) (iii)

Option 4:

(a) (b) (c) (d)
(ii) (iii) (i) (iv)

Correct Answer:

(a) (b) (c) (d)
(iii) (iv) (i) (ii)

Solution:

Correct option is (b)

(a)	Filariasis	(i)	Wuchereria bancrofti
(b)	Amoebiasis	(ii)	Entamoeba Histolytica
(c)	Pneumonia	(iii)	Haemophilus Influenzae
(d)	Ringworm	(iv)	Trichophyton

Q. 95 Following are the statements about prostomium of earthworm.

- (a) It serves as a covering for mouth
- (b) It helps to open cracks in the soil into which it can crawl.
- (c) It is one of the sensory structures.
- (d) It is the first body segment.

Choose the correct answer from the options given below.

Option 1:

(a), (b) and (c) are correct

Option 2:

(a), (b) and (d) are correct

Option 3:

(a), (b), (c) and (d) are correct

Option 4:

(b) and (c) are correct

Correct Answer:

(a), (b) and (c) are correct

Solution:

Correct option is (a)

- (a) It serves as a covering for mouth
- (b) It helps to open cracks in the soil into which it can crawl.
- (c) It is one of the sensory structures.

Q. 96 Which of the following secretes the hormone, relaxin, during the later phase of pregnancy ?

Option 1:

Graafian follicle

Option 2:

Corpus luteum

Option 3:

Foetus

Option 4:

Uterus

Correct Answer:

Corpus luteum

Solution:

Correct option is (b)

Corpus luteum

- The **ovulation** (ovulatory phase) is followed by the **luteal phase** during which the remaining parts of the Graafian follicle transform as the corpus luteum.
- The corpus luteum secretes large amounts of progesterone which is essential for the maintenance of the endometrium.
- Such an endometrium is necessary for implantation of the fertilised ovum and other events of pregnancy.
- During pregnancy, all events of the menstrual cycle stop and there is no menstruation.
- In the absence of fertilisation, the corpus luteum degenerates.

Q. 97 Which one of the following statements about Histones is **wrong** ?

Option 1:

Histones are organized to form a unit of 8 molecules.

Option 2:

The pH of histones is slightly acidic

Option 3:

Histones are rich in amino acids- Lysine and Arginine

Option 4:

Histones carry positive charge in the side chain.

Correct Answer:

The pH of histones is slightly acidic

Solution:

Correct option is (b)

Histones are basic proteins

Q. 98 Assertion (A) :

A person goes to high altitude and experiences 'altitude sickness' with symptoms like breathing difficulty and heart palpitations.

Reason (R) :

Due to low atmospheric pressure at high altitude, the body does not get sufficient oxygen.

In the light of the above statements, choose the **correct** answer from the options given below.

Option 1:

Both **(A)** and **(R)** are true and **(R)** is the correct explanation of **(A)**

Option 2:

Both **(A)** and **(R)** are true but **(R)** is not the correct explanation of **(A)**

Option 3:

(A) is true but **(R)** is false

Option 4:

(A) is false but **(R)** is true

Correct Answer:

Both **(A)** and **(R)** are true and **(R)** is the correct explanation of **(A)**

Solution:

The correct option is (a)

Both **(A)** and **(R)** are true and **(R)** is the correct explanation of **(A)**

Q. 99 Match **List-I** with **List - II**.

List - I		List - II	
(a)	Allen's Rule	(i)	Kangaroo rat
(b)	Physiological adaption	(ii)	Desert lizard
(c)	Behavioural adaption	(iii)	Marine fish at depth
(d)	Biochemical adaption	(iv)	Polar seal

Choose the **correct** answer from the options given below.

Option 1:

(a) (b) (c) (d)
(iv) (ii) (iii) (i)

Option 2:

(a) (b) (c) (d)
(iv) (i) (iii) (ii)

Option 3:

(a) (b) (c) (d)
(iv) (i) (ii) (iii)

Option 4:

(a) (b) (c) (d)
(iv) (iii) (ii) (i)

Correct Answer:

(a) (b) (c) (d)
(iv) (i) (ii) (iii)

Solution:

Correct option is (c)

(a)	Allen's Rule	(i)	Polar seal
(b)	Physiological adaption	(ii)	Kangaroo rat
(c)	Behavioural adaption	(iii)	Desert Lizard
(d)	Biochemical adaption	(iv)	Marine fish at depth

Q.
100

Match **List-I** with **List - II**.

List - I		List - II	
(a)	Adaptive radiation	(i)	Selection of resistant varieties due to excessive use of herbicides and pesticides
(b)	Convergent evolution	(ii)	Bones of forelimbs in Man and Whale
(c)	Divergent evolution	(iii)	Wings of Butterfly and Bird
(d)	Evolution by anthropogenic action	(iv)	Darwin Finches

Choose the **correct** answer from the options given below.

Option 1:

(a) (b) (c) (d)
(iv) (iii) (ii) (i)

Option 2:

(a) (b) (c) (d)
(iii) (ii) (i) (iv)

Option 3:

(a) (b) (c) (d)
(ii) (i) (iv) (iii)

Option 4:

(a) (b) (c) (d)
(i) (iv) (iii) (ii)

Correct Answer:

(a) (b) (c) (d)
(iv) (iii) (ii) (i)

Solution:

Correct option is (a)

(a)	Adaptive radiation	(i)	Darwin Finches
(b)	Convergent evolution	(ii)	Wings of Butterfly and Bird
(c)	Divergent evolution	(iii)	Bones of forelimbs in Man and Whale
(d)	Evolution by anthropogenic action	(iv)	Selection of resistant varieties due to excessive use of herbicides and pesticides

Careers360