

CAREERS 360

PRACTICE **Series**

CBSE Class 10
(2024 - 2025)

Mathematics
(Standard)

Official Sample Paper
with Solutions

SAMPLE QUESTION PAPER
Class X Session 2024-25
MATHEMATICS STANDARD (Code No.041)

TIME: 3 hours

MAX.MARKS: 80

General Instructions:

Read the following instructions carefully and follow them:

1. This question paper contains 38 questions.
2. This Question Paper is divided into 5 Sections A, B, C, D and E.
3. In Section A, Questions no. 1-18 are multiple choice questions (MCQs) and questions no. 19 and 20 are Assertion- Reason based questions of 1 mark each.
4. In Section B, Questions no. 21-25 are very short answer (VSA) type questions, carrying 02 marks each.
5. In Section C, Questions no. 26-31 are short answer (SA) type questions, carrying 03 marks each.
6. In Section D, Questions no. 32-35 are long answer (LA) type questions, carrying 05 marks each.
7. In Section E, Questions no. 36-38 are case study based questions carrying 4 marks each with sub parts of the values of 1, 1 and 2 marks each respectively.
8. All Questions are compulsory. However, an internal choice in 2 Question of Section B, 2 Questions of Section C and 2 Questions of Section D has been provided. An internal choice has been provided in all the 2 marks questions of Section E.
9. Draw neat and clean figures wherever required.
10. Take $\pi = 22/7$ wherever required if not stated.
11. Use of calculators is not allowed.

Section A		
Section A consists of 20 questions of 1 mark each.		
1.	The graph of a quadratic polynomial $p(x)$ passes through the points $(-6,0)$, $(0, -30)$, $(4,-20)$ and $(6,0)$. The zeroes of the polynomial are A) - 6,0 B) 4, 6 C) - 30,-20 D) - 6,6	1
2.	The value of k for which the system of equations $3x-ky= 7$ and $6x+ 10y =3$ is inconsistent, is A) -10 B) -5 C) 5 D) 7	1
3.	Which of the following statements is not true? A) A number of secants can be drawn at any point on the circle. B) Only one tangent can be drawn at any point on a circle. C) A chord is a line segment joining two points on the circle D) From a point inside a circle only two tangents can be drawn.	1
4.	If n th term of an A.P. is $7n-4$ then the common difference of the A.P. is A) 7 B) $7n$ C) - 4 D) 4	1

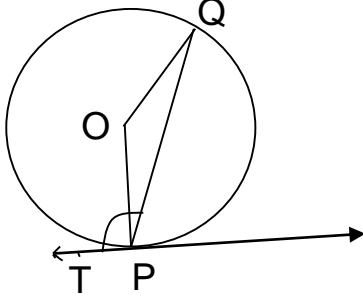
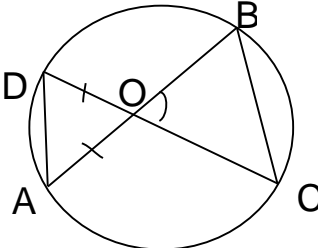
5.	<p>The radius of the base of a right circular cone and the radius of a sphere are each 5 cm in length. If the volume of the cone is equal to the volume of the sphere then the height of the cone is</p> <p>A) 5 cm B) 20 cm C) 10 cm D) 4 cm</p>	1												
6.	<p>If $\tan\theta = \frac{5}{2}$ then $\frac{4 \sin\theta + \cos\theta}{4 \sin\theta - \cos\theta}$ is equal to</p> <p>A) $\frac{11}{9}$ B) $\frac{3}{2}$ C) $\frac{9}{11}$ D) 4</p>	1												
7.	<p>In the given figure, a tangent has been drawn at a point P on the circle centred at O.</p>  <p>If $\angle TPQ = 110^\circ$ then $\angle POQ$ is equal to</p> <p>A) 110° B) 70° C) 140° D) 55°</p>	1												
8.	<p>A quadratic polynomial having zeroes - $\sqrt{\frac{5}{2}}$ and $\sqrt{\frac{5}{2}}$ is</p> <p>A) $x^2 - 5\sqrt{2}x + 1$ B) $8x^2 - 20$ C) $15x^2 - 6$ D) $x^2 - 2\sqrt{5}x - 1$</p>	1												
9.	<p>Consider the frequency distribution of 45 observations.</p> <table border="1" data-bbox="244 1272 1390 1402"> <tbody> <tr> <td>Class</td> <td>0-10</td> <td>10-20</td> <td>20-30</td> <td>30-40</td> <td>40-50</td> </tr> <tr> <td>Frequency</td> <td>5</td> <td>9</td> <td>15</td> <td>10</td> <td>6</td> </tr> </tbody> </table> <p>The upper limit of median class is</p> <p>A) 20 B) 10 C) 30 D) 40</p>	Class	0-10	10-20	20-30	30-40	40-50	Frequency	5	9	15	10	6	1
Class	0-10	10-20	20-30	30-40	40-50									
Frequency	5	9	15	10	6									
10.	<p>O is the point of intersection of two chords AB and CD of a circle.</p>  <p>If $\angle BOC = 80^\circ$ and $OA = OD$ then $\triangle ODA$ and $\triangle OBC$ are</p> <p>A) equilateral and similar B) isosceles and similar C) isosceles but not similar D) not similar</p>	1												

11.	The roots of the quadratic equation $x^2+x-1 = 0$ are A) Irrational and distinct B) not real C) rational and distinct D) real and equal	1
12.	If $\theta = 30^\circ$ then the value of $3\tan\theta$ is A) 1 B) $\frac{1}{\sqrt{3}}$ C) $\frac{3}{\sqrt{3}}$ D) not defined	1
13.	The volume of a solid hemisphere is $\frac{396}{7} \text{ cm}^3$. The total surface area of the solid hemisphere (in sq.cm) is A) $\frac{396}{7}$ B) $\frac{594}{7}$ C) $\frac{549}{7}$ D) $\frac{604}{7}$	1
14.	In a bag containing 24 balls, 4 are blue, 11 are green and the rest are white. One ball is drawn at random. The probability that drawn ball is white in colour is A) $\frac{1}{6}$ B) $\frac{3}{8}$ C) $\frac{11}{24}$ D) $\frac{5}{8}$	1
15.	The point on the x-axis nearest to the point (-4,-5) is A) (0, 0) B) (-4, 0) C) (-5, 0) D) $(\sqrt{41}, 0)$	1
16.	Which of the following gives the middle most observation of the data? A) Median B) Mean C) Range D) Mode	1
17.	A point on the x-axis divides the line segment joining the points A(2, -3) and B(5, 6) in the ratio 1:2. The point is A) (4, 0) B) $(\frac{7}{2}, \frac{3}{2})$ C) (3, 0) D) (0,3)	1
18.	A card is drawn from a well shuffled deck of playing cards. The probability of getting red face card is A) $\frac{3}{13}$ B) $\frac{1}{2}$ C) $\frac{3}{52}$ D) $\frac{3}{26}$	1
	DIRECTION: In the question number 19 and 20, a statement of Assertion (A) is followed by a statement of Reason (R) . Choose the correct option A) Both assertion (A) and reason (R) are true and reason (R) is the correct explanation of assertion (A) B) Both assertion (A) and reason (R) are true and reason (R) is not the correct explanation of assertion (A) C) Assertion (A) is true but reason (R) is false. D) Assertion (A) is false but reason (R) is true.	
19.	Assertion (A): HCF of any two consecutive even natural numbers is always 2. Reason (R): Even natural numbers are divisible by 2.	1
20.	Assertion (A): If the radius of sector of a circle is reduced to its half and angle is doubled then the perimeter of the sector remains the same.	1

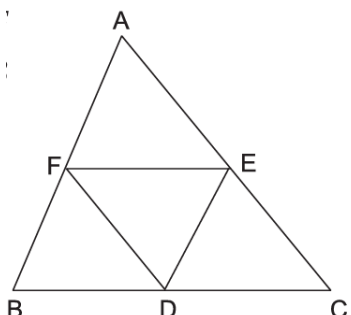
	Reason (R): The length of the arc subtending angle θ at the centre of a circle of radius r $= \frac{\pi r \theta}{180}$.	
	Section B	
	Section B consists of 5 questions of 2 marks each.	
21.	(A) Find the H.C.F and L.C.M of 480 and 720 using the Prime factorisation method. OR (A) The H.C.F of 85 and 238 is expressible in the form $85m - 238$. Find the value of m .	2
22.	(A) Two dice are rolled together bearing numbers 4, 6, 7, 9, 11, 12. Find the probability that the product of numbers obtained is an odd number OR (B) How many positive three digit integers have the hundredths digit 8 and unit's digit 5? Find the probability of selecting one such number out of all three digit numbers.	2
23.	Evaluate: $\frac{2\sin^2 60^\circ - \tan^2 30^\circ}{\sec^2 45^\circ}$	2
24.	Find the point(s) on the x-axis which is at a distance of $\sqrt{41}$ units from the point (8, -5).	2
25.	Show that the points A(-5,6), B(3, 0) and C(9, 8) are the vertices of an isosceles triangle.	2
	Section C	
	Section C consists of 6 questions of 3 marks each.	
26.	(A) In $\triangle ABC$, D, E and F are midpoints of BC, CA and AB respectively. Prove that $\triangle FBD \sim \triangle DEF$ and $\triangle DEF \sim \triangle ABC$  OR (B) In $\triangle ABC$, P and Q are points on AB and AC respectively such that PQ is parallel to BC.	3

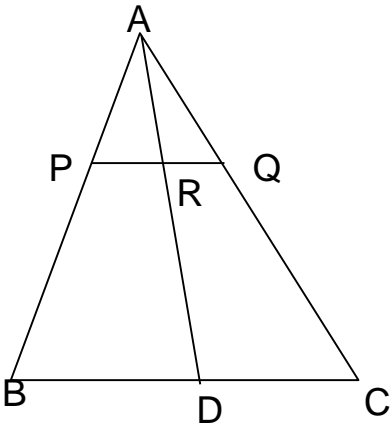
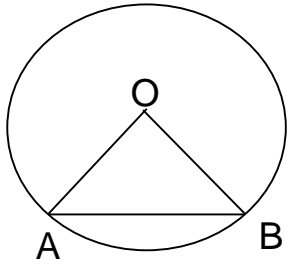
	<p>Prove that the median AD drawn from A on BC bisects PQ.</p> 	
27.	The sum of two numbers is 18 and the sum of their reciprocals is $\frac{9}{40}$. Find the numbers.	3
28.	If α and β are zeroes of a polynomial $6x^2 - 5x + 1$ then form a quadratic polynomial whose zeroes are α^2 and β^2 .	3
29.	If $\cos\theta + \sin\theta = 1$, then prove that $\cos\theta - \sin\theta = \pm 1$	3
30.	<p>(A) The minute hand of a wall clock is 18 cm long. Find the area of the face of the clock described by the minute hand in 35 minutes.</p> <p style="text-align: center;">OR</p> <p>(B) AB is a chord of a circle centred at O such that $\angle AOB = 60^\circ$. If $OA = 14$ cm then find the area of the minor segment. (take $\sqrt{3} = 1.73$)</p> 	3
31.	Prove that $\sqrt{3}$ is an irrational number.	3
	Section D	
	Section D consists of 4 questions of 5 marks each	
32.	<p>(A) Solve the following system of linear equations graphically: $x + 2y = 3$, $2x - 3y + 8 = 0$</p> <p style="text-align: center;">OR</p> <p>(B) Places A and B are 180 km apart on a highway. One car starts from A and another from B at the same time. If the car travels in the same direction at</p>	5

different speeds, they meet in 9 hours. If they travel towards each other with the same speeds as before, they meet in an hour. What are the speeds of the two cars?

33. Prove that the lengths of tangents drawn from an external point to a circle are equal.

Using above result, find the length BC of ΔABC . Given that, a circle is inscribed in ΔABC touching the sides AB, BC and CA at R, P and Q respectively and AB= 10 cm, AQ= 7cm ,CQ= 5cm.

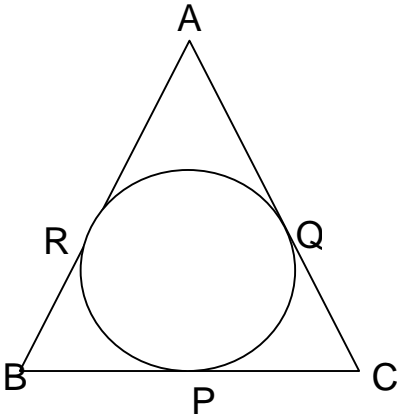

The diagram shows a triangle with vertices A at the top, B at the bottom left, and C at the bottom right. A circle is inscribed within the triangle, touching side AB at point R, side BC at point P, and side CA at point Q.

34. A boy whose eye level is 1.35 m from the ground, spots a balloon moving with the wind in a horizontal line at some height from the ground. The angle of elevation of the balloon from the eyes of the boy at an instant is 60° . After 12 seconds, the angle of elevation reduces to 30° . If the speed of the wind is 3m/s then find the height of the balloon from the ground. (Use $\sqrt{3}= 1.73$)

35. Find the mean and median of the following data:

Class	85-90	90-95	95-100	100-105	105-110	110-115
frequency	15	22	20	18	20	25

OR

The monthly expenditure on milk in 200 families of a Housing Society is given below

Monthly Expenditure (in Rs.)	1000-1500	1500-2000	2000-2500	2500-3000	3000-3500	3500-4000	4000-4500	4500-5000
Number of families	24	40	33	x	30	22	16	7

Find the value of x and also find the mean expenditure

Section E

Section E consists of 3 case study based questions of 4 marks each.

36. Ms. Sheela visited a store near her house and found that the glass jars are arranged one above the other in a specific pattern.

On the top layer there are 3 jars. In the next layer there are 6 jars. In the 3rd layer from the top there are 9 jars and so on till the 8th layer.

On the basis of the above situation answer the following questions.

(i) Write an A.P whose terms represent the number of jars in different layers starting from top . Also, find the common difference.

1

(ii) Is it possible to arrange 34 jars in a layer if this pattern is continued? Justify your answer.

1

(iii) (A) If there are 'n' number of rows in a layer then find the expression for finding the total number of jars in terms of n. Hence find S_8 .

2

OR

(iii) (B) The shopkeeper added 3 jars in each layer. How many jars are there in the 5th layer from the top?

2

37.

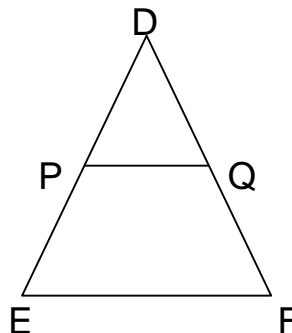
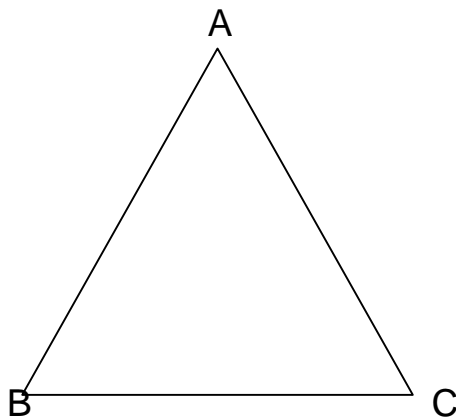

Triangle is a very popular shape used in interior designing. The picture given above shows a cabinet designed by a famous interior designer.

Here the largest triangle is represented by $\triangle ABC$ and smallest one with shelf is represented by $\triangle DEF$. PQ is parallel to EF.

(i) Show that $\triangle DPQ \sim \triangle DEF$.

1

	<p>(ii) If DP= 50 cm and PE = 70 cm then find $\frac{PQ}{EF}$.</p> <p>(iii) (A) If $2AB = 5DE$ and $\triangle ABC \sim \triangle DEF$ then show that $\frac{\text{perimeter of } \triangle ABC}{\text{perimeter of } \triangle DEF}$ is constant.</p> <p style="text-align: center;">OR</p> <p>(iii) (B) If AM and DN are medians of triangles ABC and DEF respectively then prove that $\triangle ABM \sim \triangle DEN$.</p>	<p>1</p> <p>2</p> <p>2</p>
38.	<p>Metallic silos are used by farmers for storing grains. Farmer Girdhar has decided to build a new metallic silo to store his harvested grains. It is in the shape of a cylinder mounted by a cone.</p> <p>Dimensions of the conical part of a silo is as follows: Radius of base = 1.5 m Height = 2 m</p> <p>Dimensions of the cylindrical part of a silo is as follows: Radius = 1.5 m Height = 7 m</p> <p>On the basis of the above information answer the following questions.</p> <p>(i) Calculate the slant height of the conical part of one silo.</p> <p>(ii) Find the curved surface area of the conical part of one silo.</p> <p>(iii)(A) Find the cost of metal sheet used to make the curved cylindrical part of 1 silo at the rate of ₹2000 per m^2.</p> <p style="text-align: center;">OR</p> <p>(iii) (B) Find the total capacity of one silo to store grains.</p>	<p>1</p> <p>1</p> <p>2</p> <p>2</p>

Marking Scheme
Class X Session 2024-25
MATHEMATICS STANDARD (Code No.041)

TIME: 3 hours

MAX.MARKS: 80

Q.No.	Section A	Marks
1.	D) -6,6	1
2.	B) -5	1
3.	D) From a point inside a circle only two tangents can be drawn.	1
4.	A) 7	1
5.	B) 20 cm	1
6.	A) $\frac{11}{9}$	1
7.	C) 140°	1
8.	B) $8x^2 - 20$	1
9.	C) 30	1
10.	B) isosceles and similar	1
11.	A) Irrational and distinct	1
12.	C) $\frac{3}{\sqrt{3}}$	1
13.	B) $\frac{594}{7}$	1
14.	B) $\frac{3}{8}$	1
15.	B) (-4, 0)	1
16.	A) median	1
17.	C) (3,0)	1
18.	D) $\frac{3}{26}$	1
19.	B)	1
20.	D)	1

Section B		
21. (A)	$480 = 2^5 \times 3 \times 5$ $720 = 2^4 \times 3^2 \times 5$ LCM (480,720) = $2^5 \times 3^2 \times 5 = 1440$ HCF (480, 720) = $2^4 \times 3 \times 5 = 240$	$\frac{1}{2}$ $\frac{1}{2}$ $\frac{1}{2}$ $\frac{1}{2}$
	OR	
(B)	$85 = 5 \times 17, 238 = 2 \times 7 \times 17$ HCF(85, 238) = 17 $17 = 85x - 238y$ $x = 3$	1 1
22.(A)	Total number of possible outcomes = $6 \times 6 = 36$ For a product to be odd, both the numbers should be odd. Favourable outcomes are (7,7) (7,9) (7,11) (9,7) (9,9) (9, 11) (11,7) (11,9) (11,11) no. of favourable outcomes = 9 P (product is odd) = $\frac{9}{36}$ OR $\frac{1}{4}$	$\frac{1}{2}$ 1 $\frac{1}{2}$
	OR	
(B)	Total number of three-digit numbers = 900. Numbers with hundredth digit 8 & and unit's digit 5 are 805,815, 825,.....,895 Number of favourable outcomes = 10 P(selecting one such number) = $\frac{10}{900}$ OR $\frac{1}{90}$	$\frac{1}{2}$ 1 $\frac{1}{2}$
23.	$\frac{2 \left(\frac{\sqrt{3}}{2}\right)^2 - \left(\frac{1}{\sqrt{3}}\right)^2}{(\sqrt{2})^2}$ $= \frac{7}{12}$	$1 \frac{1}{2}$ $\frac{1}{2}$
24	Let the required point be (x,0) $\sqrt{(8-x)^2 + 25} = \sqrt{41}$ $\Rightarrow (8-x)^2 = 16$ $\Rightarrow 8-x = \pm 4$ $\Rightarrow x = 4, 12$ Two points on the x-axis are (4,0) & (12,0).	$\frac{1}{2}$ $\frac{1}{2}$ 1

	$\Delta AQR \sim \Delta ACD$ $\Rightarrow \frac{AQ}{AC} = \frac{RQ}{DC} \dots\dots\dots (ii)$ Now, $\frac{AP}{AB} = \frac{AQ}{AC} \dots\dots\dots(iii)$ Using (i), (ii) & (iii), $\frac{PR}{BD} = \frac{RQ}{DC}$ But, $BD = DC$ $\Rightarrow PR = RQ$ or AD bisects PQ	1 1
27.	Let the numbers be x and 18-x. $\frac{1}{x} + \frac{1}{18-x} = \frac{9}{40}$ $\Rightarrow 18 \times 40 = 9x(18-x)$ $\Rightarrow x^2 - 18x + 80 = 0$ $\Rightarrow (x-10)(x-8) = 0$ $\Rightarrow x = 10, 8.$ $\Rightarrow 18-x = 8, 10$ Hence two numbers are 8 and 10.	$\frac{1}{2}$ 1 1 $\frac{1}{2}$
28.	From given polynomial $\alpha + \beta = \frac{5}{6}, \alpha\beta = \frac{1}{6}$ $\alpha^2 + \beta^2 = \left(\frac{5}{6}\right)^2 - 2 \times \frac{1}{6} = \frac{13}{36}$ And $\alpha^2 \beta^2 = \left(\frac{1}{6}\right)^2 = \frac{1}{36}$ $x^2 - \frac{13}{36}x + \frac{1}{36}$ \Rightarrow Required polynomial is $36x^2 - 13x + 1$	1 1 $\frac{1}{2}$ $\frac{1}{2}$
29.	$(\cos\theta + \sin\theta)^2 + (\cos\theta - \sin\theta)^2 = 2(\cos^2\theta + \sin^2\theta) = 2$ $\Rightarrow (1)^2 + (\cos\theta - \sin\theta)^2 = 2$ $\Rightarrow (\cos\theta - \sin\theta)^2 = 1$ $\Rightarrow \cos\theta - \sin\theta = \pm 1$	$1 \frac{1}{2}$ 1 $\frac{1}{2}$
30.(A)	Angle described by minute hand in 5 min = 30° . length of minute hand = 18 cm = r. Area swept by minute hand in 35 minutes $= \left(\frac{22}{7} \times 18 \times 18 \times \frac{30}{360}\right) \times 7$ $= 594 \text{ cm}^2.$ OR	2 1
(B)	Area of minor segment = Ar. Sector OAB - Ar. Δ OAB $= \frac{90}{360} \times \frac{22}{7} \times 14 \times 14 - \frac{\sqrt{3}}{4} \times 14 \times 14$ $= 69.23 \text{ cm}^2$	2 1

34.

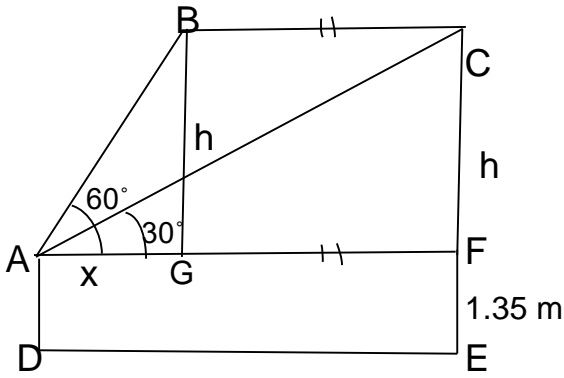

Let A be the eye level & B, C are positions of balloon
 Distance covered by balloon in 12 sec = $3 \times 12 = 36$ m
 $BC = GF = 36$ m

$$\tan 60^\circ = \sqrt{3} = \frac{h}{x}$$

$$\Rightarrow h = x \sqrt{3} \dots\dots (i)$$

$$\tan 30^\circ = \frac{1}{\sqrt{3}} = \frac{h}{x+36}$$

$$\Rightarrow h = \frac{x+36}{\sqrt{3}} \dots\dots (ii)$$

Solving (i) and (ii) $h = 18\sqrt{3} = 31.14$ m
 Height of balloon from ground = $1.35 + 31.14 = 32.49$ m

Correct figure 1 mark

1
1
1
1

35.

Class	x	f	$u = \frac{x-102.5}{5}$	fu	cf
85-90	87.5	15	-3	-45	15
90-95	92.5	22	-2	-44	37
95-100	97.5	20	-1	-20	57
100-105	102.5	18	0	0	75
105-110	107.5	20	1	20	95
110-115	112.5	25	2	50	120
		$\Sigma f = 120$		$\Sigma fu = -39$	

Mean = $\bar{x} = 102.5 - 5 \times \frac{39}{120}$
 $= 100.875$
 Median class is 100-105
 Median = $100 + \frac{5}{18} (60-57) = 100.83$

OR

Correct table 2marks

1
1/2
1/2
1

Monthly Expenditure	f_i	x_i	$f_i x_i$	Correct table 2marks
1000-1500	24	1250	30,000	
1500-2000	40	1750	70,000	
2000-2500	33	2250	74,250	
2500-3000	X=28	2750	77,000	
3000-3500	30	3250	97,500	
3500-4000	22	3750	82,500	
4000-4500	16	4250	68,000	
4500-5000	7	4750	33,250	
$172+x=200$ $X=28$ Mean = $\frac{532500}{200}$ = 2662.5				1 1 1
Section E				
36. (i)	First term $a = 3$, A.P is 3, 6, 9, 12.....,24 common difference $d = 6-3 = 3$			$\frac{1}{2}$ $\frac{1}{2}$
(ii)	$34 = 3 + (n-1)3$ $\Rightarrow n = \frac{34}{3} = 11\frac{1}{3}$ which is not a positive integer. Therefore, it is not possible to have 34 jars in a layer if the given pattern is continued.			$\frac{1}{2}$ $\frac{1}{2}$
(iii)(A)	$S_n = \frac{n}{2} [2 \times 3 + (n-1) 3]$ $= \frac{n}{2} [6 + 3n-3]$ $= \frac{n}{2} [3+3n]$ $= 3 \frac{n}{2} [1+n]$ $s_8 = 3 \times \frac{8}{2} (1+8)$ = 108			$\frac{1}{2}$ 1
	OR			
(iii) (B)	A.P will be 6, 9, 12, $a = 6, d = 3$ $t_5 = 6 + (5-1)3$ = 6 + 12 = 18			$\frac{1}{2}$ 1 $\frac{1}{2}$
37. (i)	$\angle DPQ = \angle DEF$			
	$\angle PDQ = \angle EDF$			
(ii)	Therefore $\Delta DPQ \sim \Delta DEF$ $DE = 50 + 70 = 120$ cm $\frac{DP}{DE} = \frac{PQ}{EF}$			1 $\frac{1}{2}$

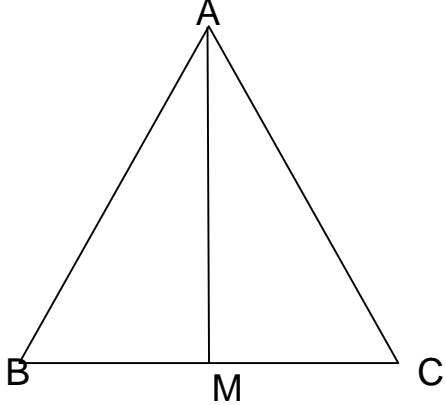
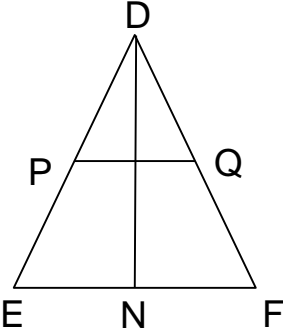
<p>(iii) (A)</p>	<p>Therefore $\frac{PQ}{EF} = \frac{50}{120}$ or $\frac{5}{12}$</p> $\frac{AB}{DE} = \frac{5}{2} = \frac{BC}{EF} = \frac{AC}{DF}$ $\Rightarrow AB = \frac{5}{2} DE$ $\frac{\text{perimeter of } \triangle ABC}{\text{perimeter of } \triangle DEF} = \frac{\frac{5}{2}(DE + EF + FD)}{DE + EF + FD} = \frac{5}{2} \text{ (Constant)}$ <p style="text-align: center;">OR</p> <div style="display: flex; justify-content: space-around; align-items: center;">   </div> $\frac{AB}{DE} = \frac{BC}{EF} = \frac{BC/2}{EF/2} = \frac{BM}{EN}$ <p>Also $\angle B = \angle E$</p> <p>Therefore $\triangle ABM \sim \triangle DEN$.</p>	<p>$\frac{1}{2}$</p> <p>1</p> <p>1</p> <p>Correct fig. $\frac{1}{2}$ mark</p> <p>1</p> <p>$\frac{1}{2}$</p>
<p>38. (i)</p> <p>(ii)</p> <p>(iii) (A)</p> <p>(iii) (B)</p>	$l = \sqrt{r^2 + h^2}$ $= \sqrt{(1.5)^2 + (2)^2}$ $= \sqrt{2.25 + 4}$ $= \sqrt{6.25}$ $= 2.5 \text{ m}$ <p>CSA of cone = $\pi r l$</p> $= \frac{22}{7} \times 1.5 \times 2.5$ $= 11.78 \text{ m}^2$ <p>CSA of cylinder = $2\pi r h$</p> $= 2 \times \frac{22}{7} \times 1.5 \times 7$ $= 66 \text{ m}^2$ <p>Cost of metal sheet used = 66×2000</p> $= ₹1,32,000$ <p style="text-align: center;">OR</p> <p>Volume of cylinder = $\pi r^2 h$</p> $= \frac{22}{7} \times (1.5)^2 \times 7$ $= 49.5 \text{ m}^3$	<p>$\frac{1}{2}$</p> <p>$\frac{1}{2}$</p> <p>$\frac{1}{2}$</p> <p>1</p> <p>1</p> <p>$\frac{1}{2}$</p>

	<p>Volume of cone = $\frac{1}{3} \pi r^2 h$</p> $= \frac{1}{3} \times \frac{22}{7} \times (1.5)^2 \times 2$ $= 4.71 \text{ m}^3$ <p>Total capacity = $49.5 + 4.71 = 54.21 \text{ m}^3$</p>	<p>1</p> <p>$\frac{1}{2}$</p>
--	--	--