

# **CAREERS 360**

## **PREPARATION** **Series**

# **Distance and Direction Reasoning**

---

**All Questions with Solutions**

---

**Q. 1**     **Directions:** Sunita walks 45 metres towards the south, then turns right and walks another 45 metres. She then turns right and walks for 20 metres to reach point L. She then again turns to her right and walks for 45 metres. How far (in metres) is she from point L?

**Option 1:**  
50 metres

**Option 2:**  
45 metres

**Option 3:**  
25 metres

**Option 4:**  
60 metres

**Correct Answer:**  
45 metres

**Solution:**

Firstly, we will draw the diagram as per the given instructions –

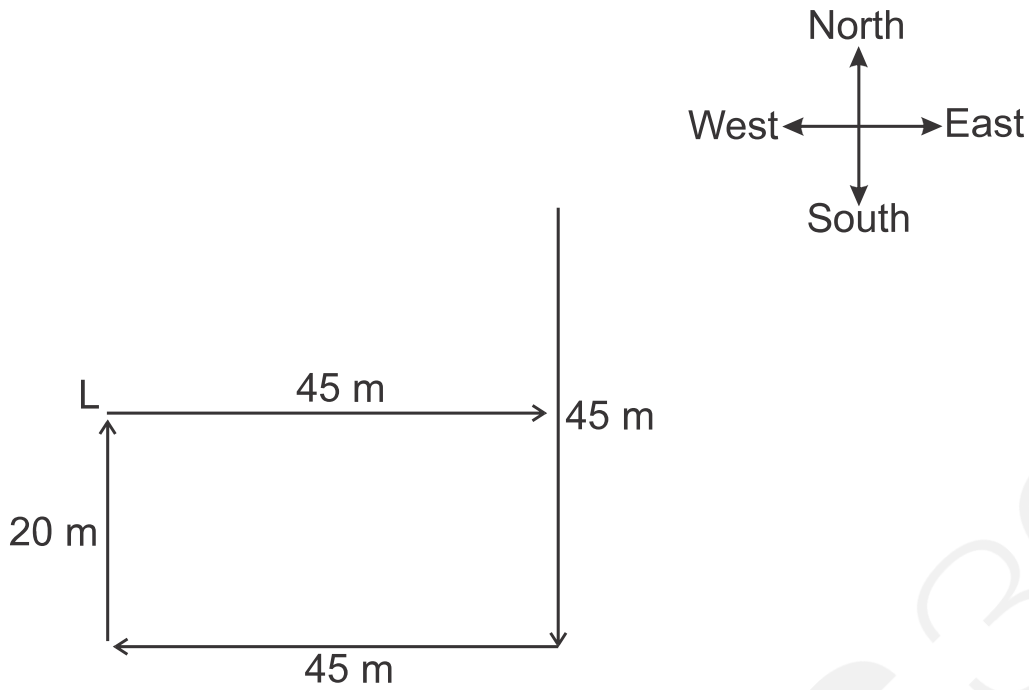

Now, we have to find the distance between point L and the endpoint covered by Sunita.

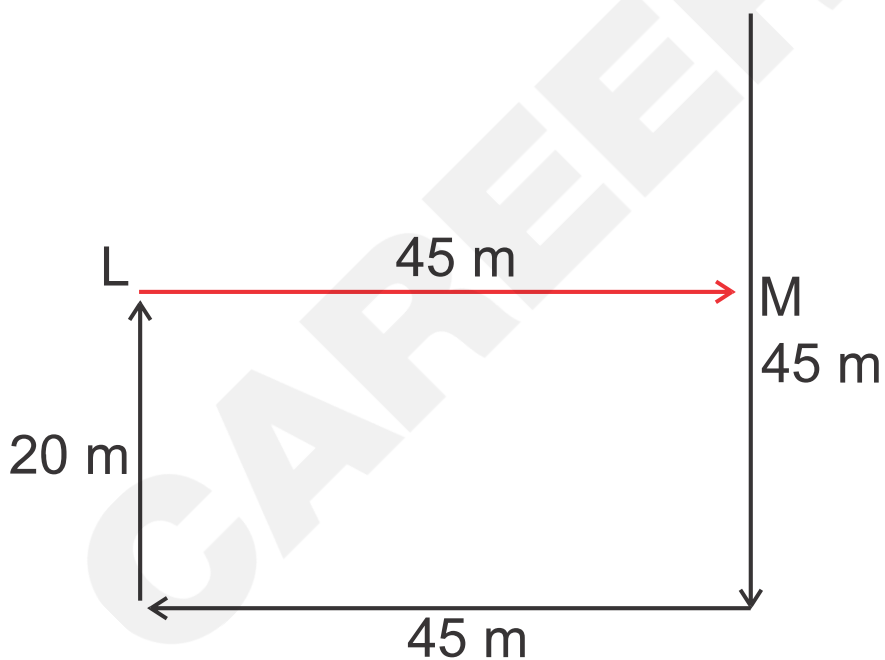

The distance between point L and the endpoint  
= LM  
= 45 m

The distance between point L and the endpoint covered by Sunita is 45 metres. Hence, the **second option** is correct.

**Q. 2**     **Directions:** A migrating bird flies 40 km north, then turns east and flies 50 km, then turns north and flies 110 km, and turns to its left and flies 50 km. Where is it now with reference to its starting position?

**Option 1:**  
150 km south

**Option 2:**  
150 km north

**Option 3:**  
70 km north

**Option 4:**  
70 km south

**Correct Answer:**  
150 km north

**Solution:**

As per the given information, the movement of the bird will look as follows –

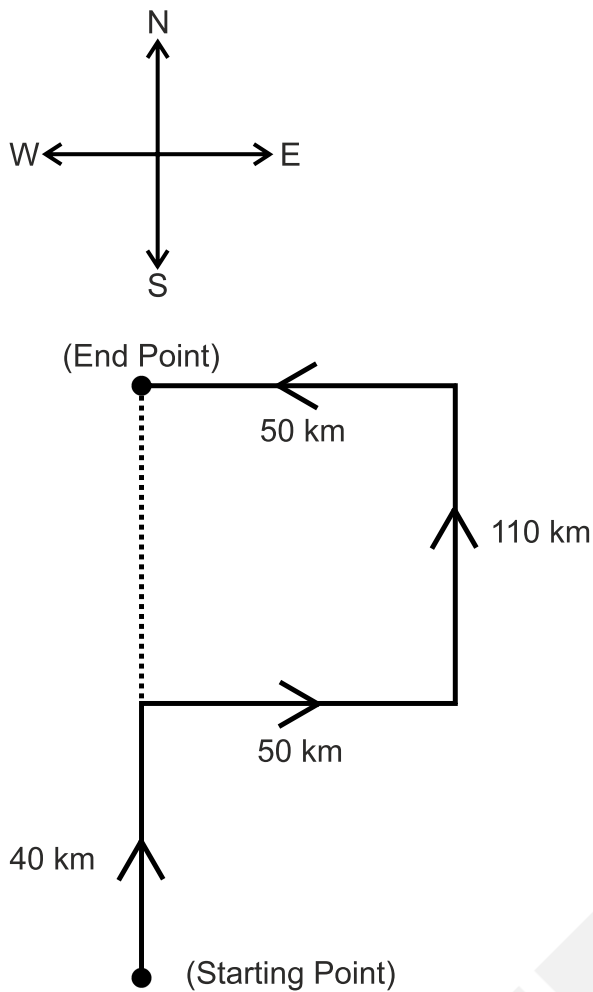

The distance between the migrating bird's starting point and end point  
 $= 40 + 110 = 150$  km

The distance between the migrating bird's starting and end points is 150 km and the migrating bird is in the north direction with respect to its starting position. Hence, the **second option** is correct.

- Q. 3**     **Directions:** Sonal stands to the north of Amar and the west of Mahi. In which direction is Mahi standing with respect to Amar?

**Option 1:**

South-West

**Option 2:**

North-West

**Option 3:**

North-East

**Option 4:**

South-East

**Correct Answer:**

North-East

**Solution:**

**Given:**

Sonal stands to the north of Amar and to the west of Mahi.

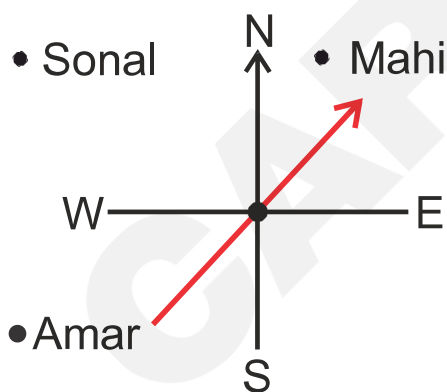

Therefore, Mahi stands North-East of Amar. Hence, the **third option** is correct.

**Q. 4**     **Directions:** From a point, Lokesh starts walking towards the south, and after walking 30 metres, he turns to his right and walks 20 metres, then he turns right again and walks 30 metres. He finally turns to his left and walks 40 metres. In which direction is he pointing with reference to the starting point?

**Option 1:**  
North-West

**Option 2:**  
East

**Option 3:**  
West

**Option 4:**  
South

**Correct Answer:**  
West

**Solution:**

Firstly, we will draw the diagram as per the given instructions –

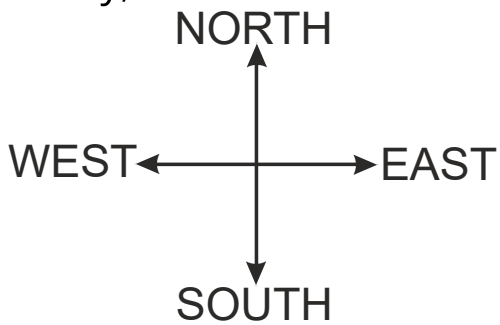

As per the given information, the movement of Lokesh will be –

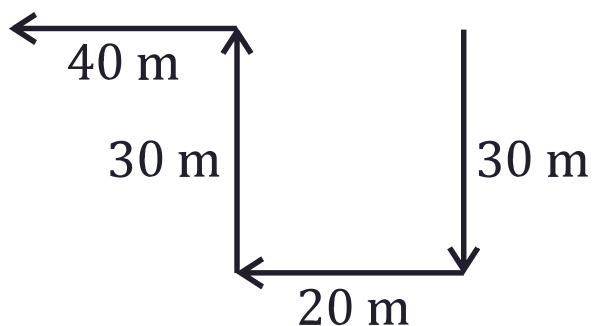

Therefore, Lokesh is facing the West concerning the starting point. Hence, the **third option** is correct.

- Q. 5**     **Directions:** Kritika walks 40 m towards the south. Then, turning to her right, she rides 30 m. Then, turning to her left, she rides 50 m. Again, she turns to her left and rides 30 m. How far (in m) is she from her initial position?

**Option 1:**

65 m

**Option 2:**

70 m

**Option 3:**

80 m

**Option 4:**

90 m

**Correct Answer:**

90 m

**Solution:**

Firstly, we will draw the diagram as per the given instructions –

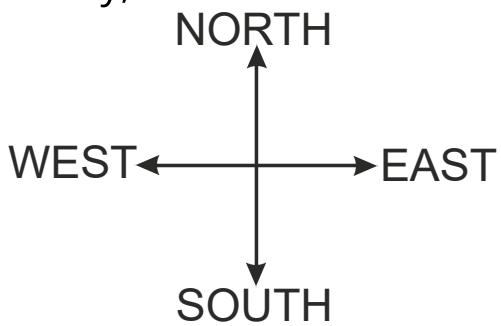

Now, we have to find the distance between starting and end point –

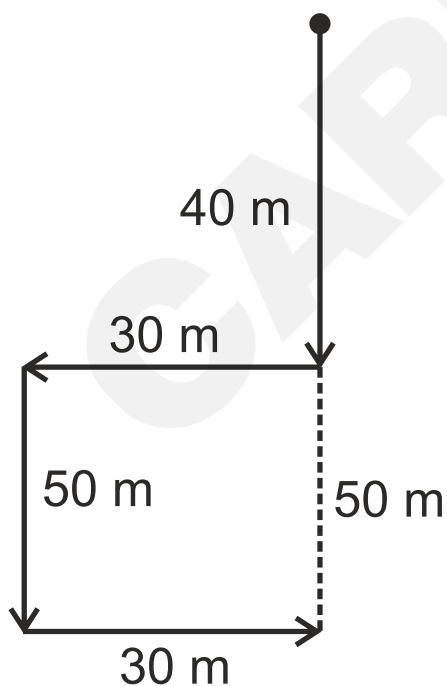

Therefore, the distance between Kritika's final point and starting point =  $40 + 50 = 90$  m. Hence, the **fourth option** is correct.

**Q. 6**     **Directions:** Kamal starts walking from his home, facing west. After walking 10 km, he takes a right turn and walks another 10 km. He takes another right turn and walks 10 km to reach his school. How far (in km) and in which direction is he from his home?

**Option 1:**  
10 km North

**Option 2:**  
10 km South

**Option 3:**  
20 km North-east

**Option 4:**  
20 km South-west

**Correct Answer:**  
10 km North

**Solution:**

As per the given information, the movement of Kamal will be –

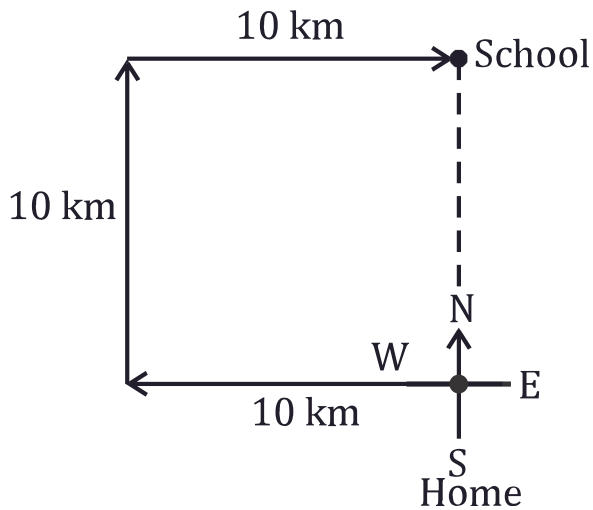

So, Kamal is in the north direction with respect to his starting point (home) and the distance between Kamal's endpoint (school) and his home is 10 km. Hence, the **first option** is correct.

- Q. 7**     **Directions:** A plane flies 100 km west, then turns south and flies 150 km, then turns west and flies 300 km, then turns to its right and flies 150 km. Where is it now with reference to its starting position?

**Option 1:**  
400 km east

**Option 2:**  
200 km west

**Option 3:**  
400 km west

**Option 4:**

200 km east

**Correct Answer:**

400 km west

**Solution:**

Firstly, we will draw the diagram as per the given instructions –

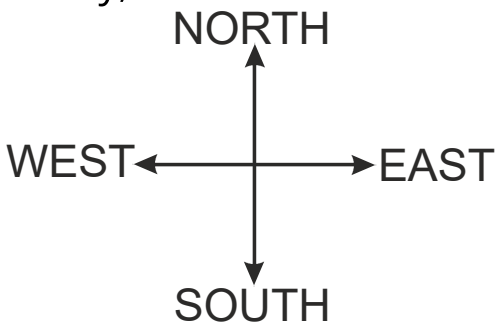

Now, we have to find the distance from the starting point to the endpoint –

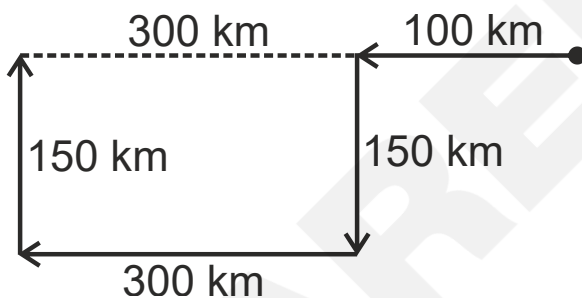

The distance from the starting point to the endpoint =  $300 + 100 = 400$  km

Therefore, the plane is in the west direction with respect to its starting point, and the distance between its starting point and final point is 400 km. Hence, the **third option** is correct.

**Q. 8** **Directions:** A paperboy cycles 10 km east, then turns south and cycles 3 km, then turns west and cycles 6 km, then turns to his right and cycles 3 km. Where is he now with reference to his starting position?

**Option 1:**  
4 km west

**Option 2:**  
14 km east

**Option 3:**  
4 km east

**Option 4:**  
14 km west

**Correct Answer:**  
4 km east

**Solution:**

Firstly, we will draw the diagram as per the given instructions –

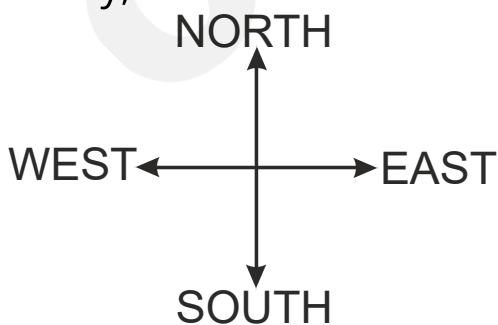

Now, we have to find distance and the final position with respect to the starting position –

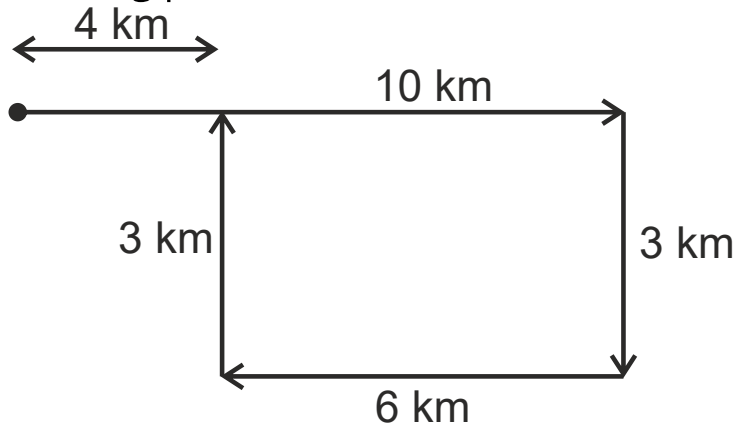

The distance between starting position and end point =  $10 - 6 = 4$  km

Therefore, the paperboy is in the East direction with respect to his starting position and the distance between his starting point and final point is 4 km. Hence, the **third option** is correct.

- Q. 9**      **Directions:** A man walks 10 km in the east direction and then turns to the right and moves 5 km in that direction. Then, he takes a left turn and moves 2 km ahead. Find the minimum distance between his initial and final positions.

**Option 1:**

12 km

**Option 2:**

13 km

**Option 3:**

7 km

**Option 4:**

18 km

**Correct Answer:**

13 km

**Solution:**

Firstly, draw a diagram as per the given instructions –

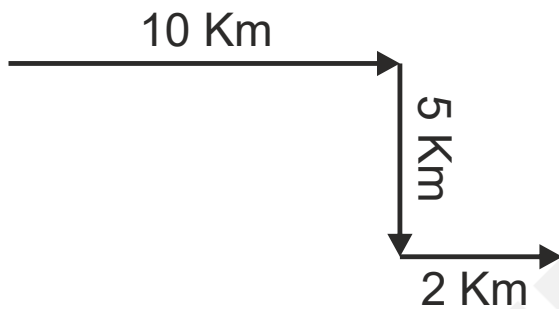

Now, we have to find the shortest distance –

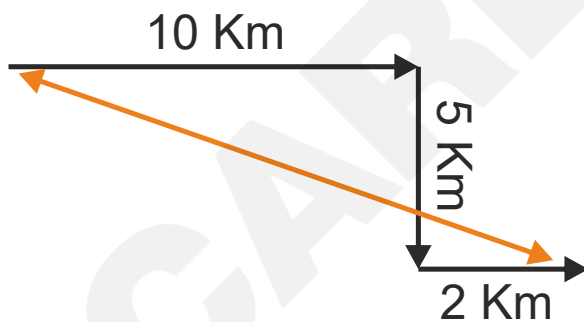

Apply Pythagoras' theorem to the given triangle, ABC –

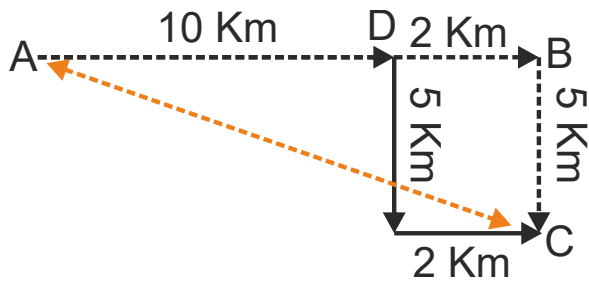

$$(\text{Hypotenuse})^2 = (\text{Perpendicular})^2 + (\text{Base})^2$$

$$AC^2 = BC^2 + AB^2$$

$$AC^2 = (5)^2 + (10 + 2)^2$$

$$AC^2 = (5)^2 + (12)^2$$

$$AC^2 = 25 + 144$$

$$AC^2 = 169$$

$$AC = \sqrt{169}$$

$$AC = 13 \text{ km}$$

So, the shortest distance between the starting and the endpoints is 13 km.  
Hence, the **second option** is correct.

- Q. 10** **Directions:** Vineet travels 16 km towards the west, turns right, travels another 12 km, and then takes two successive left turns, covering 8 km and 12 km after each turn, respectively. Finally, he takes a right turn and travels 10 km farther. How far is he now from his original position?

**Option 1:**

46 km

**Option 2:**

34 km

**Option 3:**

40 km

**Option 4:**

38 km

**Correct Answer:**

34 km

**Solution:**

Draw a diagram as per the given details –

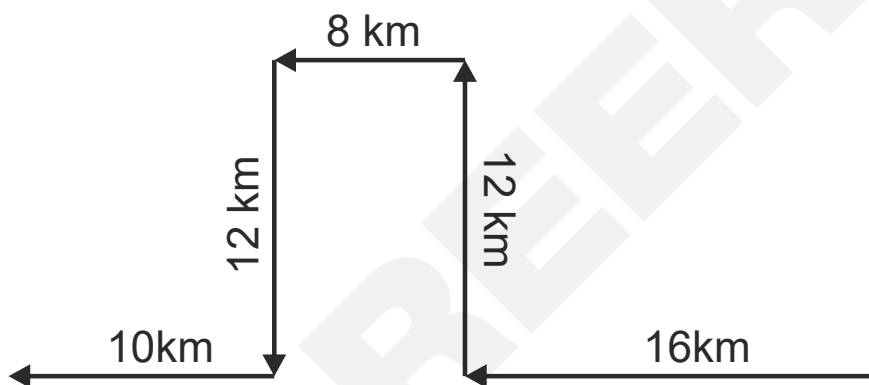

Now, find the distance between the starting and endpoints –

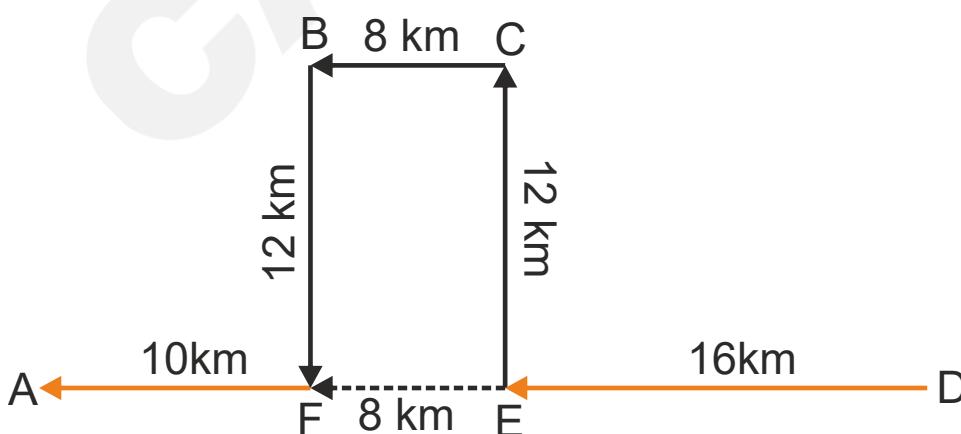

The distance between the starting point and the endpoint  
= AF + FE + ED  
= 10 + 8 + 16  
= 34 km

So, the distance between the starting point and endpoint is 34 km. Hence, the **second option** is correct.

---

**Q. 11** **Directions:** Preetam cycles 6 km in the south direction. He turns right to move 8 km and again, turns towards the northeast to move 10 km. From there, he moves 15 km to the left. How far is he from his original position?

**Option 1:**  
15 km

**Option 2:**  
10 km

**Option 3:**  
55 km

**Option 4:**  
65 km

**Correct Answer:**  
15 km

**Solution:**

Draw a diagram to represent the given details –

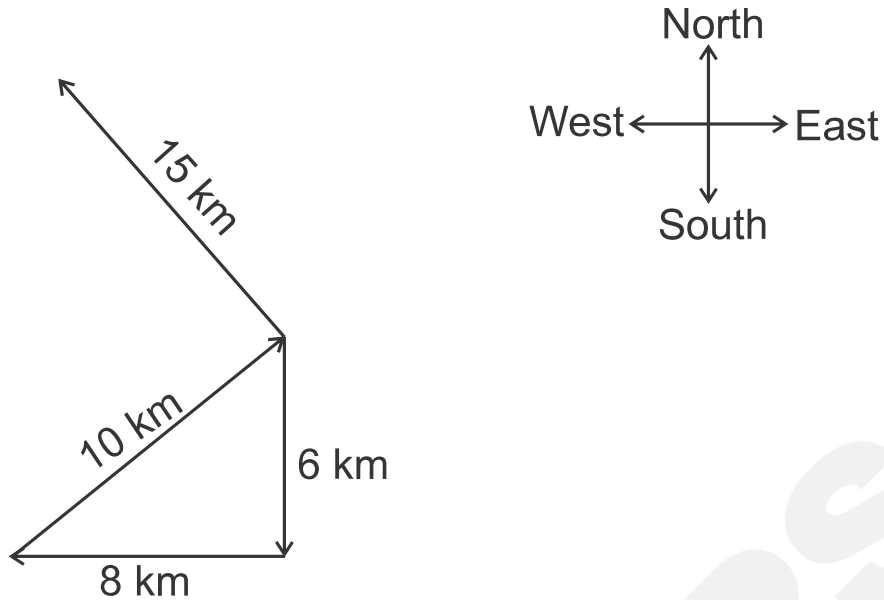

Now, we have to find the distance between the starting point and the endpoint –

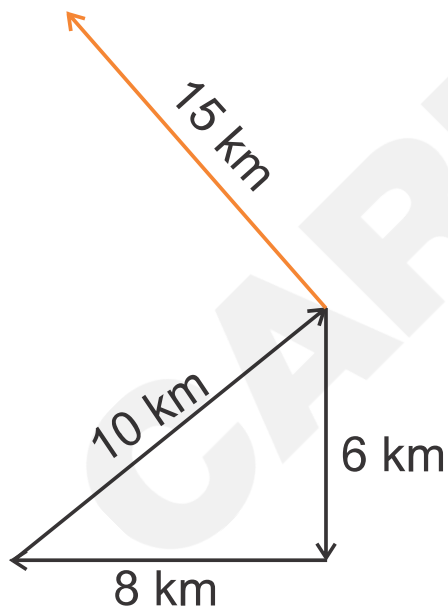

The distance between the starting point and the endpoint = 15 km

Hence, the **first option** is correct.

**Q. 12** **Directions:** Ravi's house is to the west of Ankit's house. Lavi's house is to the north of Ankit's house. In which direction is Lavi's house with respect to Ravi's house?

**Option 1:**  
South-West

**Option 2:**  
North-East

**Option 3:**  
North-West

**Option 4:**  
South-East

**Correct Answer:**  
North-East

**Solution:**

Firstly, we will draw the diagram as per the given instructions –

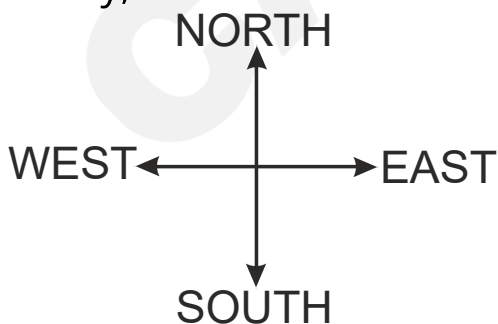

Now, we have to find in which direction Lavi's house with respect to Ravi's house.

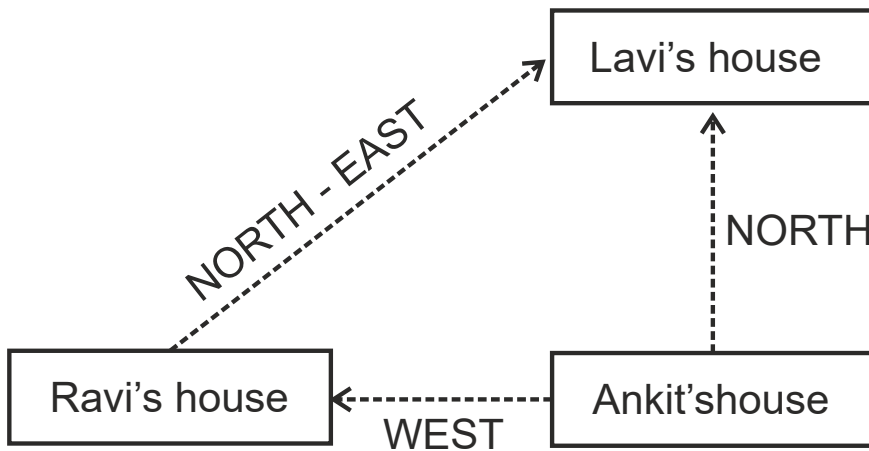

Therefore, Lavi's house is to the northeast of Ravi's house. Hence, the **second option** is correct.

- Q. 13** **Directions:** Rajan cycles 8 km in the south direction and takes a left turn to travel another 8 km. He again takes a left turn to travel 8 km further. In which direction is he now from his original position?

**Option 1:**  
East

**Option 2:**  
North-west

**Option 3:**  
South-east

**Option 4:**

South

**Correct Answer:**

East

**Solution:**

Firstly, we will draw the diagram as per the given instructions –

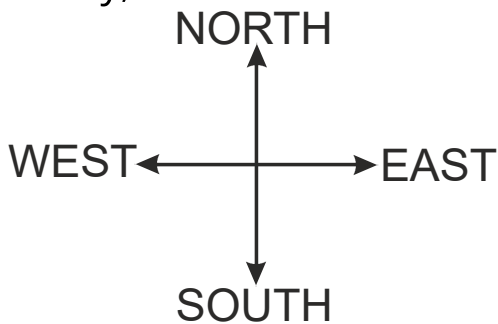

Now, we have to find the direction of Rajan with respect to the starting position –

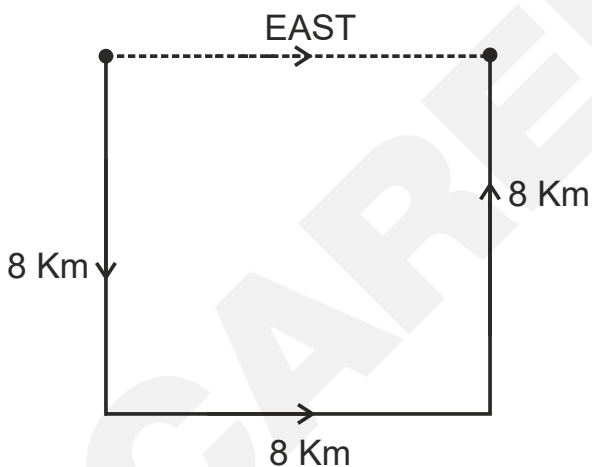

Therefore, Rajan is in the East from his original position. Hence, the **first option** is correct.

**Q. 14** **Directions:** Gurpreet is facing south. She turns right and walks 35 meters, then turns right again and walks 40 meters more. Finally, she turns left and walks 30 meters. In which direction is she facing now?

**Option 1:**

South

**Option 2:**

North

**Option 3:**

West

**Option 4:**

East

**Correct Answer:**

West

**Solution:**

Firstly, we will draw the diagram as per the given instructions –

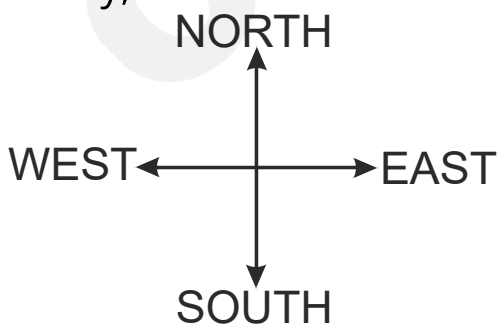

Now, we have to find in which direction Gurpreet is facing in the final position.

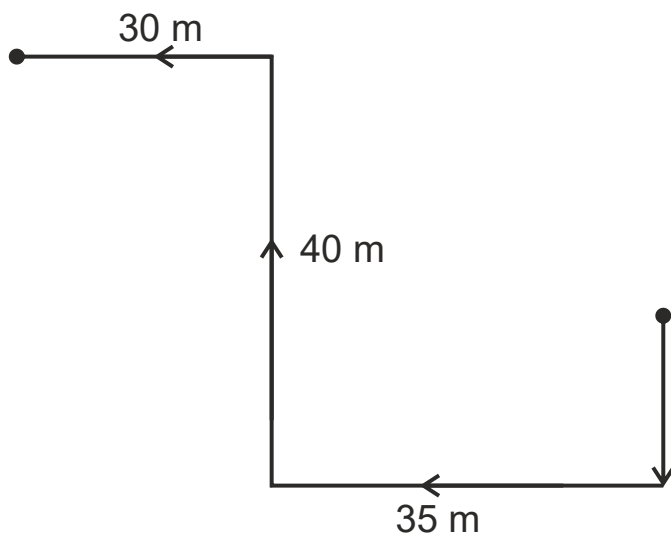

Therefore, finally, Gurpreet is facing towards the West direction.  
Hence, the **third option** is correct.

---

**Q. 15** **Directions:** Mohan is chasing a bike that is moving in the south-west direction. In which direction is Mohan moving?

**Option 1:**  
North

**Option 2:**  
East

**Option 3:**  
North-east

**Option 4:**

South-west

**Correct Answer:**

South-west

**Solution:**

As per the given information, if Mohan is chasing a bike that is moving in the south-west direction then, Mohan is also moving in the south-west direction.

Hence, the **fourth option** is correct.

---

**Q. 16**    **Directions:** Rahul's school is in the north-east direction from his house. In which direction is his house from his school?

**Option 1:**

North-West

**Option 2:**

South-West

**Option 3:**

North-East

**Option 4:**

West

**Correct Answer:**  
South-West

**Solution:**

As per the given information, the direction of Rahul's house and school is as follows –

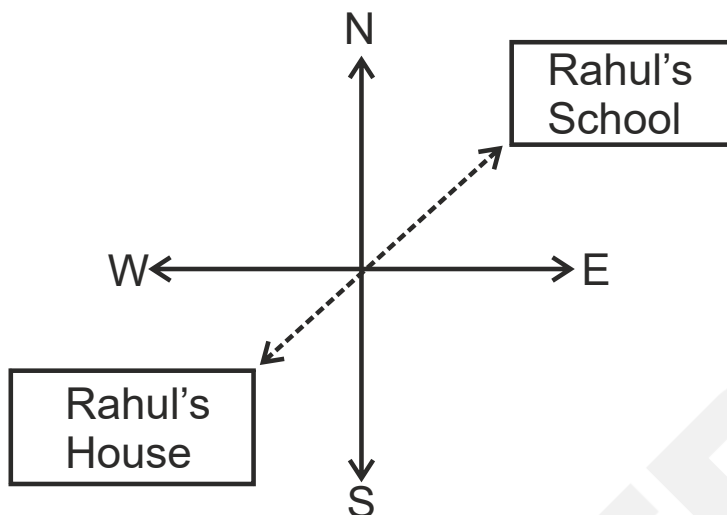

Thus, Rahul's house is in the south-west direction from his school. Hence, the **second option** is correct.

**Q. 17** **Directions:** A boy and a girl are facing each other. If the boy is facing the northwest direction, in which direction is the girl facing?

**Option 1:**  
North

**Option 2:**  
South

**Option 3:**

East

**Option 4:**

South-East

**Correct Answer:**

South-East

**Solution:**

As per the given information, the direction of girl and boy will look as follows –

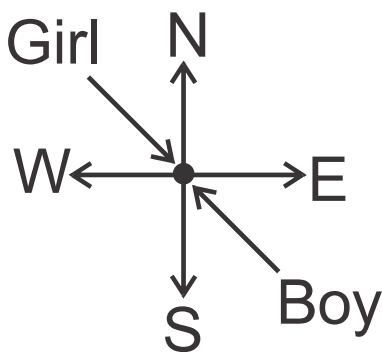

Therefore, if the boy is facing the northwest direction and both are facing each other, then the girl is facing the southeast direction. Hence, the **fourth option** is correct.

- 
- Q. 18** **Directions:** A man walks from a point towards the south. He turns right at the right angle, then turns right again at the right angle. In what direction is he walking now?

**Option 1:**

West

**Option 2:**

North

**Option 3:**

South

**Option 4:**

East

**Correct Answer:**

North

**Solution:**

First, we will draw the diagram as per the given instructions –

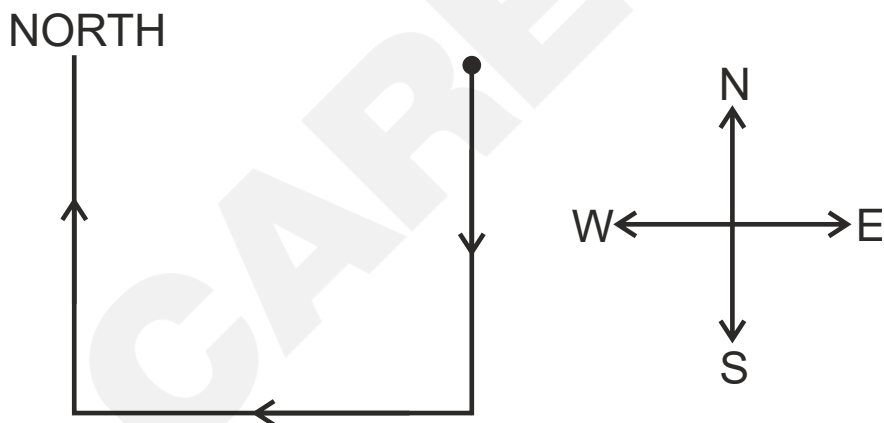

Therefore, from the above diagram, it is clear that the man is walking North. Hence, the **second option** is correct.

**Q. 19** **Directions:** A man facing south turns to his left and walks 10 m, then he turns to his right and walks 15 m, again, he turns to his left and walks 5 m, and then he turns to his left and walks 15 m. In which direction is he facing now?

**Option 1:**

West

**Option 2:**

North

**Option 3:**

South

**Option 4:**

East

**Correct Answer:**

North

**Solution:**

First, we will draw the diagram as per the given instructions –

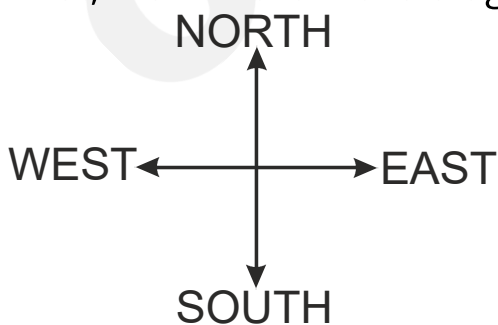

Now, we have to find in which direction man is facing now.

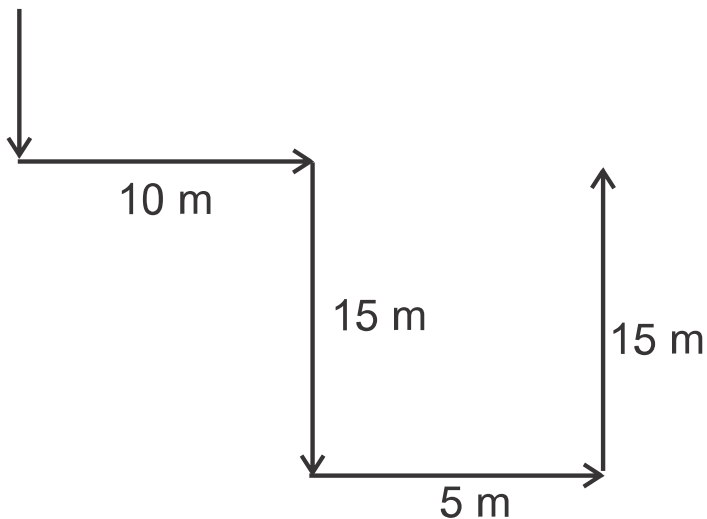

Therefore, the man is facing North. Hence, the **second option** is correct.

**Q. 20** **Directions:** Z started walking straight towards the south. He walked a distance of 15 m and then took a left turn and walked a distance of 30 m. Then he took a right turn and walked a distance of 15 m again. Z is facing which direction?

**Option 1:**  
West

**Option 2:**  
East

**Option 3:**  
South

**Option 4:**

North

**Correct Answer:**

South

**Solution:**

First, we will draw the diagram as per the given instructions –

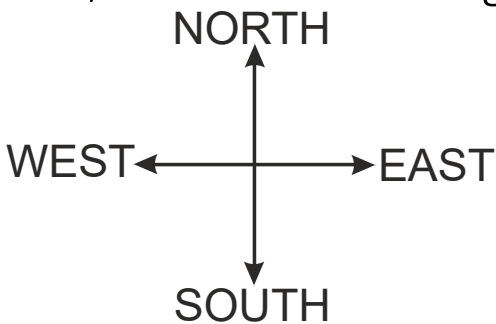

Now, we have to find in which direction Z is facing at the final position.

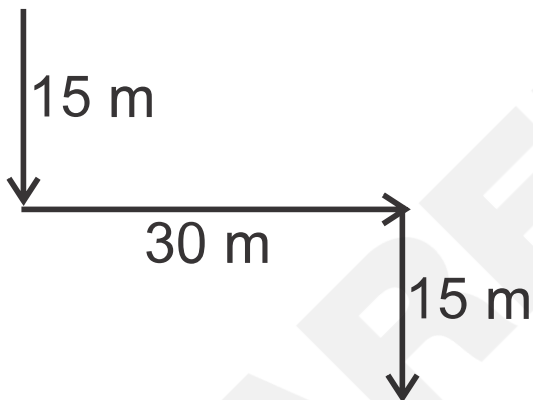

Therefore, Z is facing South. Hence, the **third option** is correct.

- Q. 21** **Directions:** Keshav walks 15 km towards the south. He takes a right turn and walks 25 km. He takes a right turn and walks 10 km. In which direction is he from his starting point?

**Option 1:**

South-West

**Option 2:**

South

**Option 3:**

South-East

**Option 4:**

West

**Correct Answer:**

South-West

**Solution:**

As per the given instructions, the movement of Keshav will look as follows –

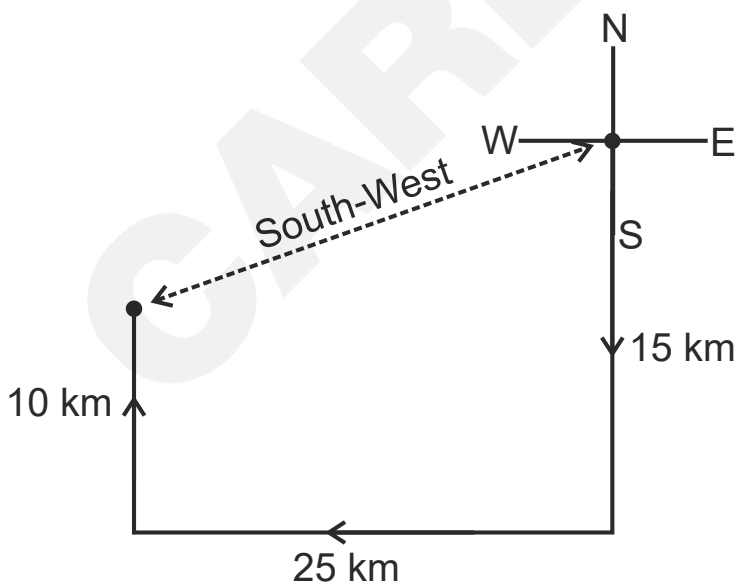

Therefore, the direction of Keshav from his starting position is South-West. Hence, the **first option** is correct.

**Q. 22**     **Directions:** P walks 15 km towards the east. He turns right and walks 10 kilometers. He turns right and walks 15 kilometers. How far (in kilometers) is he from his starting point?

**Option 1:**

5

**Option 2:**

10

**Option 3:**

15

**Option 4:**

25

**Correct Answer:**

10

**Solution:**

Firstly, we will draw the diagram as per the given instructions –

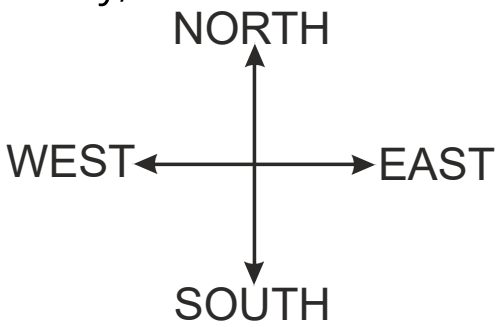

Now, we have to find the distance between the starting point and the endpoint.

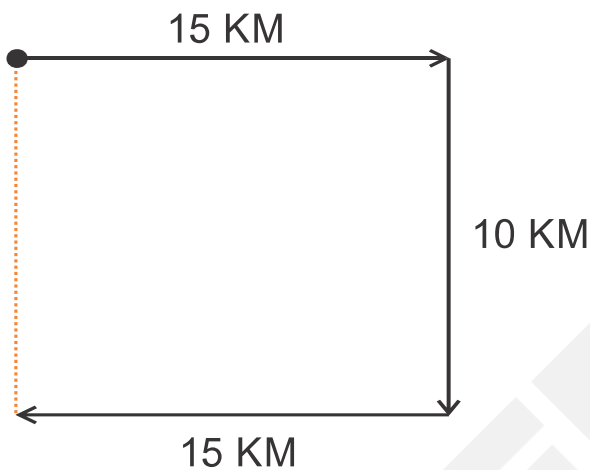

So, the distance between P and the starting point is 10 km. Hence, the **second option** is correct.

- 
- Q. 23** **Directions:** Rohini walks 10 kilometers north and turns right. She walks 10 kilometers and then, turns left. She walks 10 km and then, turns right and walks 10 km more. How far (in kilometers) is she from her starting point?

**Option 1:**

20

**Option 2:**

$10\sqrt{2}$

**Option 3:**

$20\sqrt{2}$

**Option 4:**

40

**Correct Answer:**

$20\sqrt{2}$

**Solution:**

Firstly, we will draw the diagram as per the given instructions –

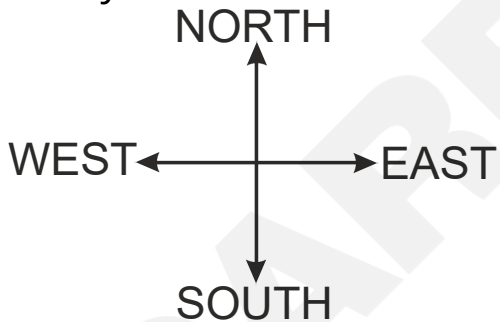

Now, we have to find the shortest distance between starting point and end point –

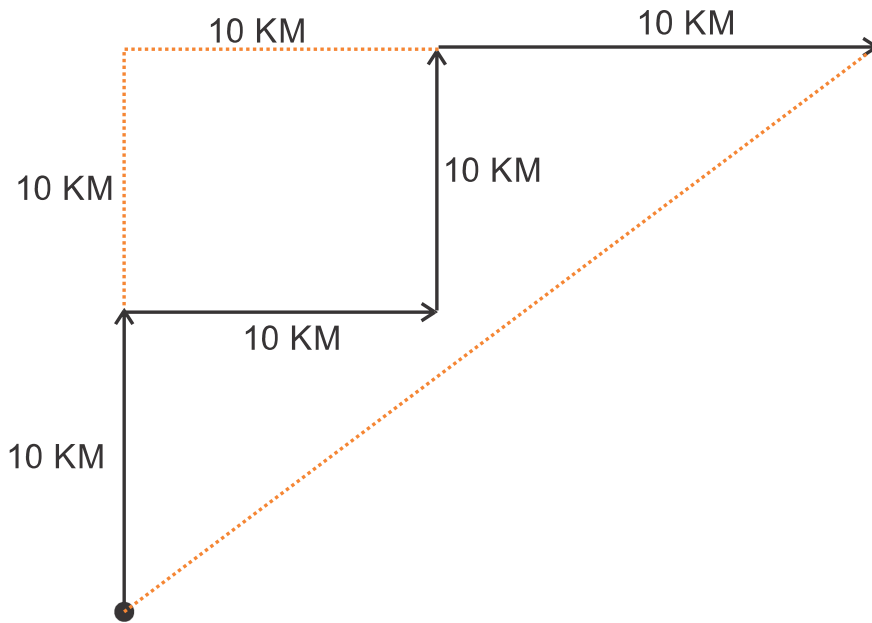

Now, find the distance between the starting point and the end point by using Pythagoras' Theorem –

$$(\text{Hypotenuse})^2 = (\text{Perpendicular})^2 + (\text{Base})^2$$

$$H^2 = (10 + 10)^2 + (10 + 10)^2$$

$$H^2 = (20)^2 + (20)^2$$

$$H^2 = 400 + 400$$

$$H^2 = 800$$

$$H = 20\sqrt{2}$$

So, the distance between Rohini and the starting point is  $20\sqrt{2}$  km. Hence, the **third option** is correct.

- Q. 24** **Directions:** Suman walks 15 kilometers towards the north. She turns right and walks another 15 kilometers. She turns right and walks another 15 kilometers. In which direction is she from her starting point?

**Option 1:**

North

**Option 2:**

South

**Option 3:**

East

**Option 4:**

West

**Correct Answer:**

East

**Solution:**

Firstly, we will draw the diagram as per the given instructions –

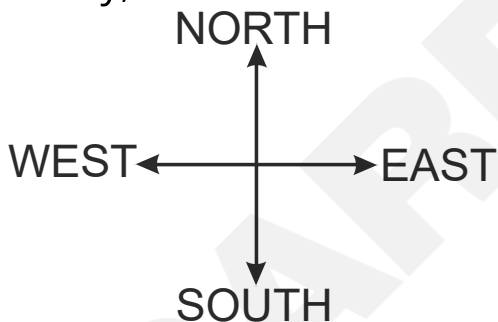

Now, we have to find the direction of Suman with respect to the starting point.

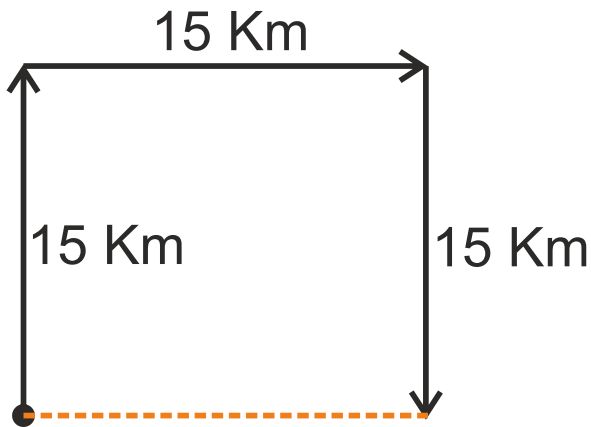

So, the direction in which Suman is from her starting point is east. Hence, the **third option** is correct.

**Q. 25** **Directions:** Mani starts from college and walks 3 km towards the east, turns right and walks 2 km, turns right again, and walks. What is the direction he is now facing?

**Option 1:**  
South

**Option 2:**  
North

**Option 3:**  
West

**Option 4:**  
East

**Correct Answer:**

West

**Solution:**

Firstly, we will draw the diagram as per the given instructions –

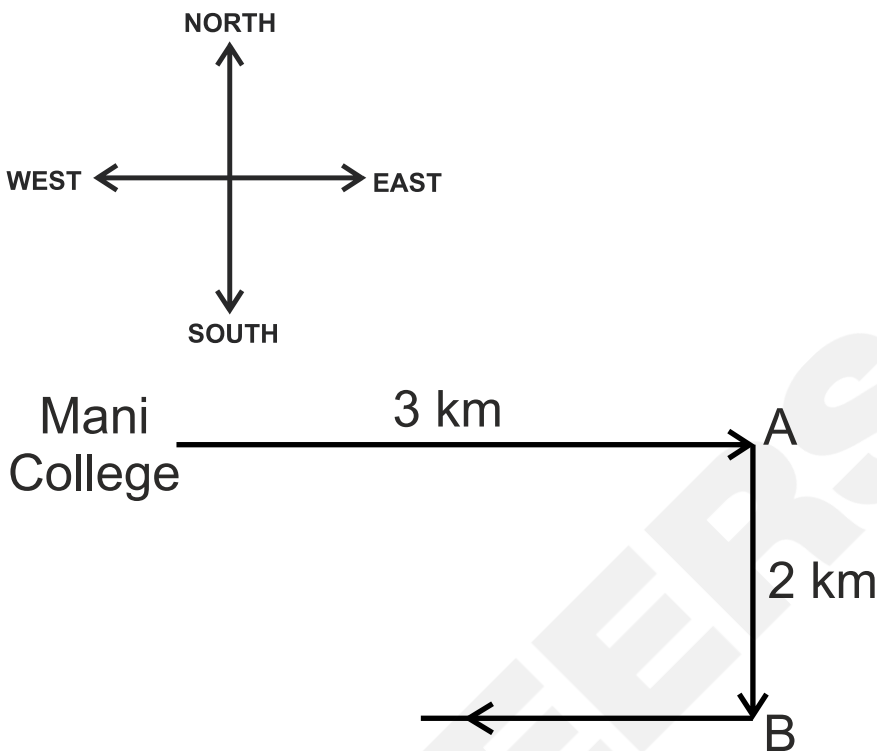

So, Mani is facing towards the West direction. Hence, the **third option** is correct.

- Q. 26** **Directions:** After walking 10 m, Shankar turned left covered a distance of 6 m, then turned right and covered a distance of 20 m. In the end, he was moving towards the south. From which direction did Shankar start his journey?

**Option 1:**

West

**Option 2:**

North

**Option 3:**

South

**Option 4:**

East

**Correct Answer:**

North

**Solution:**

To determine the direction of the starting journey, we have to move in reverse order. As per the given information, the movement of Shankar will look as follows –

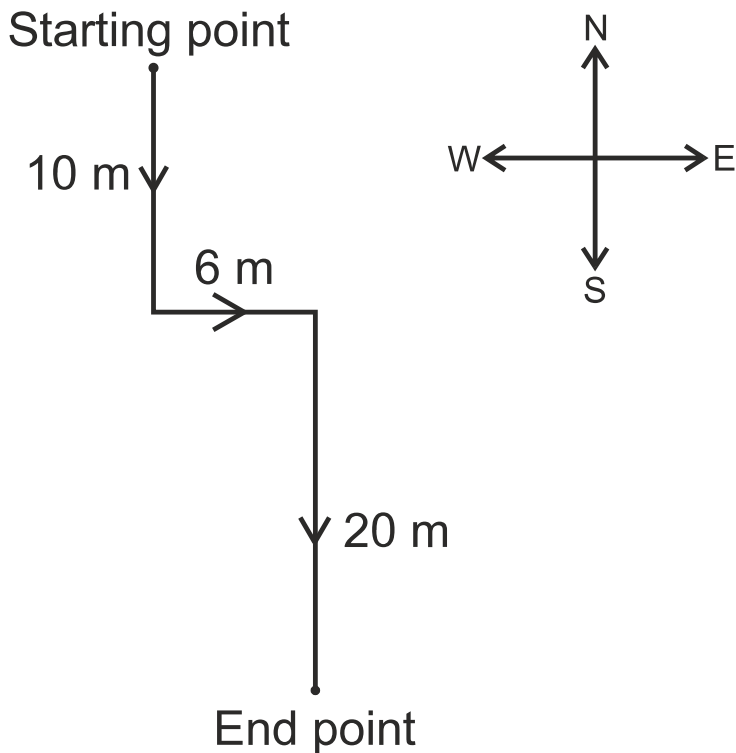

So, according to the above diagram, Shankar started his journey from the North. Hence, the **second option** is correct.

**Q. 27** **Directions:** Tina drives 45 km towards the east, turns right and drives 65 km, then turns left and drives 33 km. In which direction is she facing now?

**Option 1:**

East

**Option 2:**

North

**Option 3:**

West

**Option 4:**

South

**Correct Answer:**

East

**Solution:**

First, we will draw the diagram as per the given instructions –

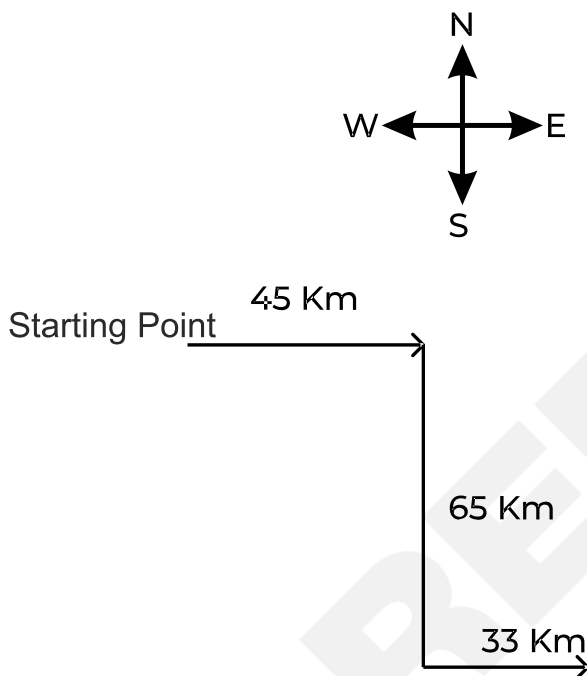

So, Tina is facing in the East direction. Hence, the **first option** is correct.

**Q. 28 Directions:** A man walks 6 km South, turns left and walks 4 km, again turns left and walks 5 km. Which direction is he facing now?

**Option 1:**

South

**Option 2:**

North

**Option 3:**

East

**Option 4:**

West

**Correct Answer:**

North

**Solution:**

First, we will draw the diagram as per the given instructions –

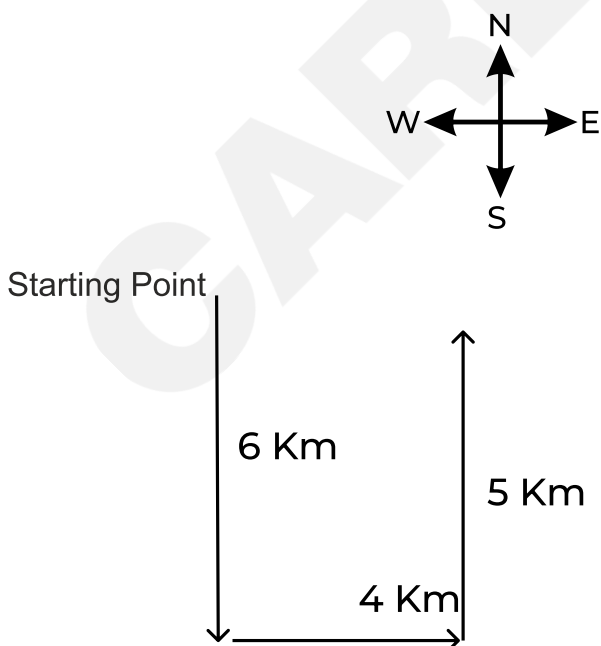

So, the man is facing in the North direction. Hence, the **second option** is correct.

**Q. 29** **Directions:** One morning, Rita started to walk towards the sun. After walking a while, she turned to her left and again to her left. After walking a while, she again turned right. Which direction is she facing now?

**Option 1:**  
East

**Option 2:**  
West

**Option 3:**  
North

**Option 4:**  
South

**Correct Answer:**  
North

**Solution:**

In the morning, the sun rises in the East. So, Rita will start walking towards the sun in the East direction.

Now, we will draw the diagram as per the given instructions –

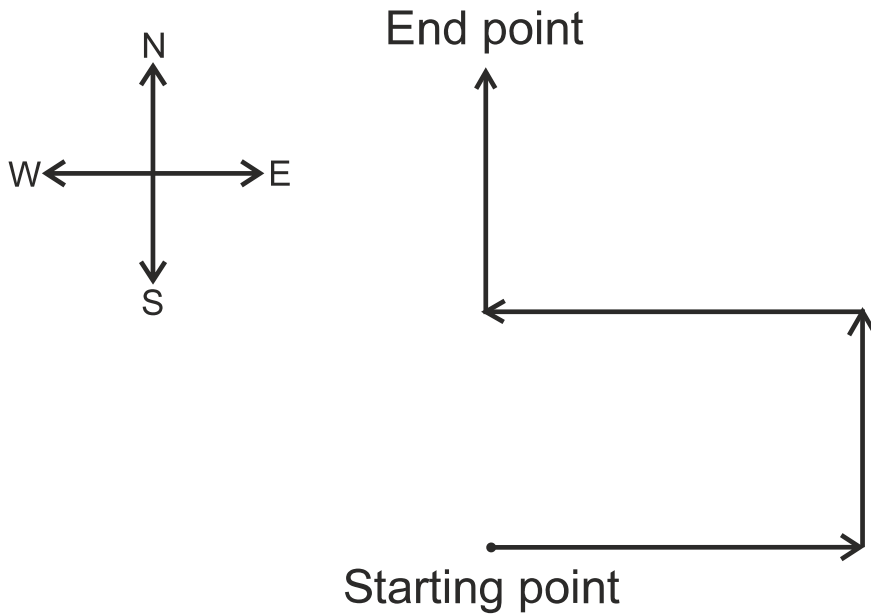

Thus, Rita is facing the north direction. Hence, the **third option** is correct.

- Q. 30** **Directions:** Rajan started from his house and went 2 km east, then he turned right and went 3 km, again turned right and went 3 km, again he turned right and covered 1 km, and finally, after turning right and going 1 km, he reached point K. In which direction was Rajan walking when he reached?

**Option 1:**  
West

**Option 2:**  
East

**Option 3:**

South

**Option 4:**

North

**Correct Answer:**

East

**Solution:**

Firstly, we will draw the diagram as per the given instructions –

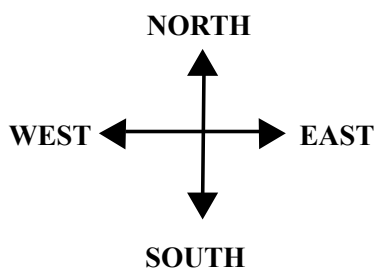

Now, we have to find the direction of Rajan when he reaches point K.

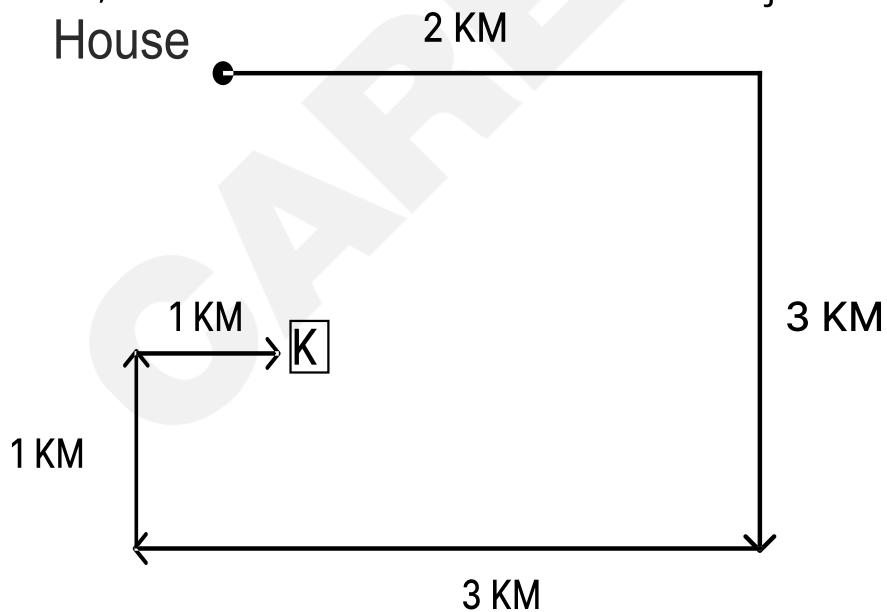

So, Rajan was walking in the east direction when he reached point K. Hence, the **second option** is correct.

**Q. 31** **Directions:** A girl leaves her home. She first walks 30 m in the northwest direction and then 30m in the southwest direction. Next, she walks 30 m in a southeast direction. Finally, she turns towards her house. In which direction is she moving?

**Option 1:**  
North-West

**Option 2:**  
South-East

**Option 3:**  
South-West

**Option 4:**  
North-East

**Correct Answer:**  
North-East

**Solution:**

Firstly, we will draw the diagram as per the given instructions –

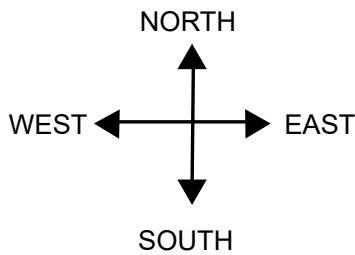

Now, we have to find the direction in which she is moving now.

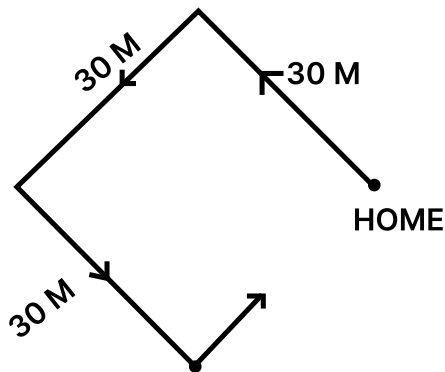

From the above final diagram, it is clear that the girl was moving to the northeast. Hence, the **fourth option** is correct.

- Q. 32** **Directions:** Johnson left for his office in his car. He drove 15 km towards the North and then 10 km towards the West. He then turned to the South and covered 5 km. Further, he turned to East and moved 8 km. Finally, he turned right and moved 10 km. How far and in which direction is he from his starting point?

**Option 1:**  
2 km, West

**Option 2:**

5 km, East

**Option 3:**

3 km, North

**Option 4:**

3 km, South

**Correct Answer:**

2 km, West

**Solution:**

Firstly, we will draw the diagram as per the given instructions –

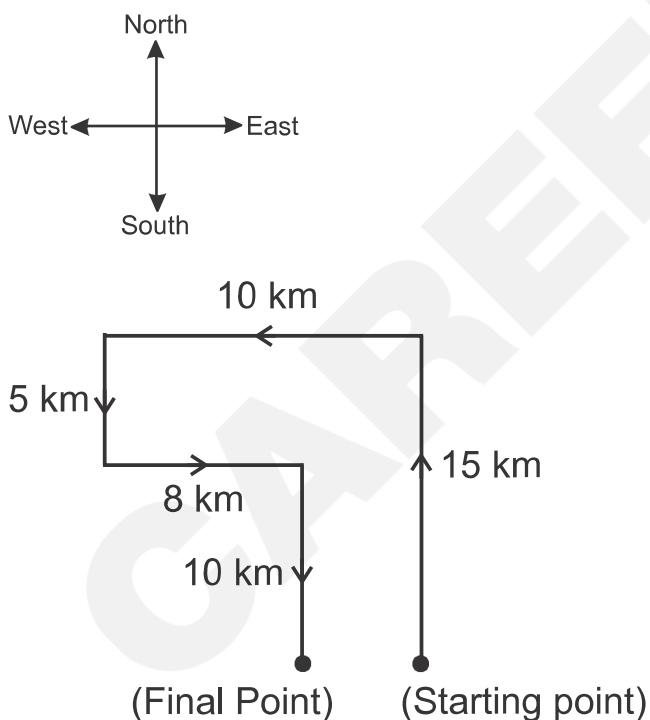

From the above diagram, the distance between the starting and the end point is  $10 \text{ km} - 8 \text{ km} = 2 \text{ km}$

The final point is in the West direction from the starting point.

So, Johnson is in the West direction and is at a distance of 2 km from the starting point. Hence, the **first option** is correct.

**Q. 33** **Directions:** To attend an exam, Sudhir reached the school by travelling 5 km towards the south, and after a sharp left turn, he travelled for about 10 km. He again made a sharp left turn and reached the school by travelling 5 km more. Which direction is Sudhir's starting point from the school?

**Option 1:**

East

**Option 2:**

West

**Option 3:**

North

**Option 4:**

South

**Correct Answer:**

West

**Solution:**

Firstly, draw the direction and distance diagram according to the instructions –

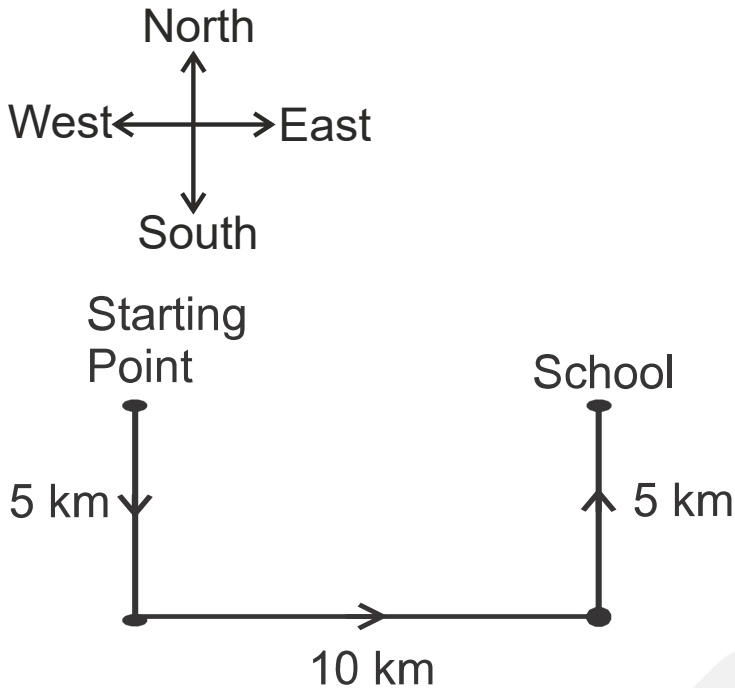

From the above diagram, it is clear that Sudhir's starting point is in the West direction from the school.

Therefore, West is the correct answer. Hence, the **second option** is correct.

- Q. 34** **Directions:** Mr. A travelled from point X straight towards the east at a distance of 80 m. He turned to his right and walked 40 m. He again turned to his right and walked 80 m. He then turned his left and walked 20 m, then took a left and walked again 80 m. Now he turned towards his left and walked 60 m and stopped. How far and in which direction is he from the starting point X?

**Option 1:**

80 m towards the North

**Option 2:**

60 m towards the East

**Option 3:**

80 m towards the West

**Option 4:**

80 m towards the East

**Correct Answer:**

80 m towards the East

**Solution:**

Firstly, we will draw the diagram as per the given instructions –

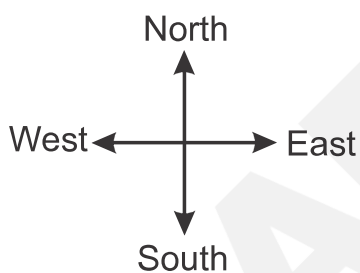

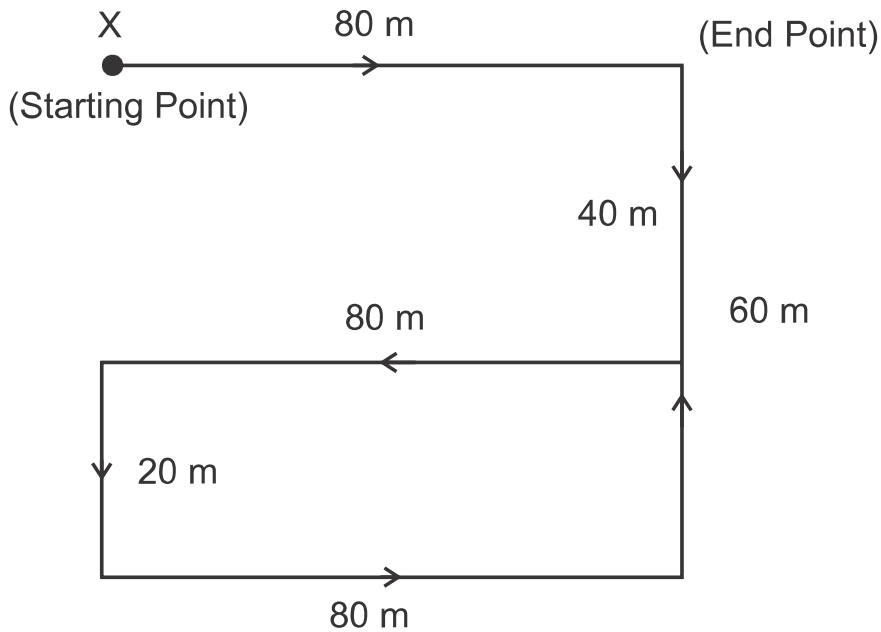

From the above diagram, the distance between the starting and the endpoint is 80 m and the endpoint is in the East direction from the starting point.

So, Mr. A is in the East direction and is at a distance of 80 m from the starting point. Hence, the **fourth option** is correct.

- Q. 35** **Directions:** Shalu walks 30 m north, then she turns right and walks 30 m then she turns right and walks 55 m. Then she turns left and walks 20 m. Then she again turns left and walks 25 m. How many meters away and in which direction is she from her original position?

**Option 1:**  
20 m, South

**Option 2:**

10 m, North

**Option 3:**

30 m, North

**Option 4:**

50 m, East

**Correct Answer:**

50 m, East

**Solution:**

Firstly, we will draw the diagram as per the given instructions –

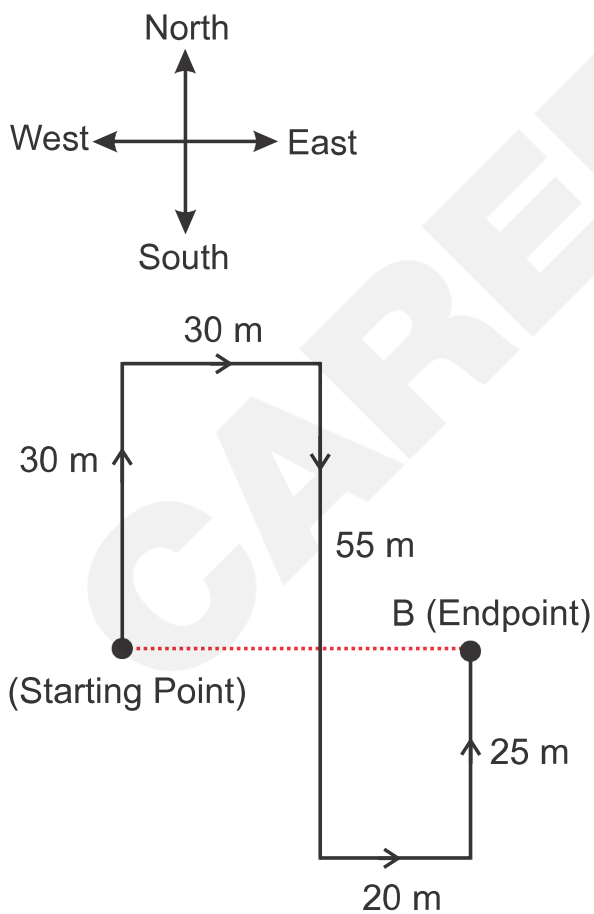

From the above diagram, the distance between the starting and the endpoint is 50 m and the endpoint is in the East direction from the starting point.

So, Shalu is in the East direction and is at a distance of 50 m from the starting point. Hence, the **fourth option** is correct.

---

**Q. 36**     **Directions:** Rahul travels 10 km towards the East, then he takes a left turn and travels 3 km. He then takes the right turn and travels 5 km, he again takes the right turn and travels 8 km and finally takes the right turn one more time and travels 3 km. How far is he from his starting point and in which direction?

**Option 1:**

12 km towards South-East

**Option 2:**

13 km towards North-West

**Option 3:**

12 km towards North-West

**Option 4:**

13 km towards South-East

**Correct Answer:**

13 km towards South-East

**Solution:**

Firstly, we will draw the diagram as per the given instructions –

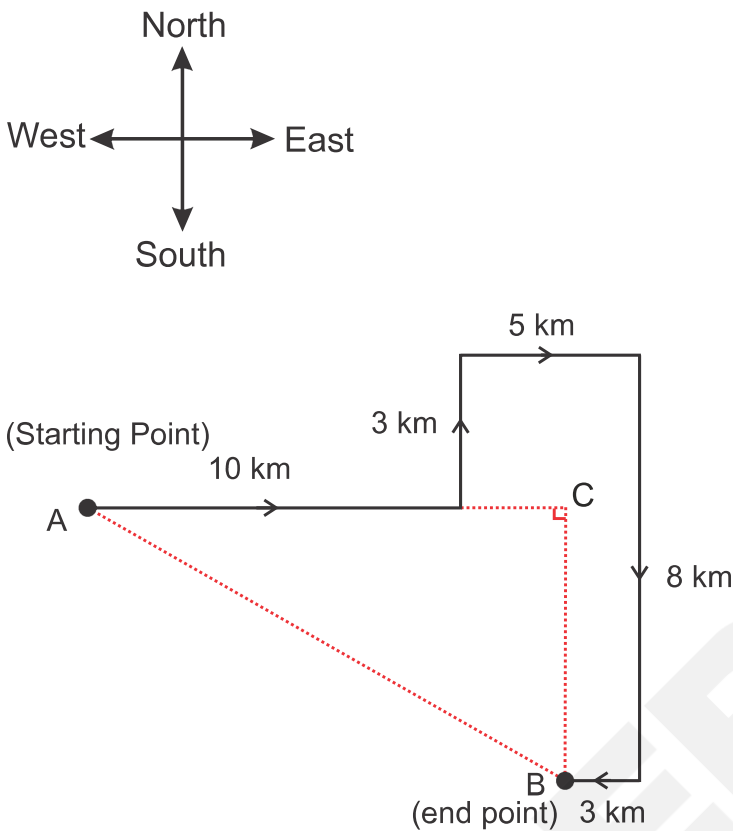

From the above diagram, it is clear that Rahul is in the South-East direction from his starting point.

For the shortest distance (AB) between the starting point and the endpoint, use Pythagoras theorem,

$$\Rightarrow (AC)^2 + (BC)^2 = (AB)^2$$

$$\Rightarrow (12)^2 + (5)^2 = (AB)^2$$

$$\Rightarrow 144 + 25 = (AB)^2$$

$$\Rightarrow (AB)^2 = 169$$

$$\Rightarrow AB = 13 \text{ km}$$

Thus, Rahul is towards the South-East direction and 13 km away from the starting point. Hence, the **fourth option** is correct.

**Q. 37** **Directions:** A girl walks 100 m straight from her home, to go to the market during her morning walk. Then she turns left for 60 m, then 85 m turning her right, and then again turns right for 60 m, she can see her shadow now. Therefore, in which direction is the entry gate of her house facing and what is the shortest distance from her current location to her home?

**Option 1:**  
South, 185 m

**Option 2:**  
North, 185 m

**Option 3:**  
East, 160 m

**Option 4:**  
North, 160 m

**Correct Answer:**  
South, 185 m

**Solution:**

Firstly, we will draw the diagram as per the given instructions –

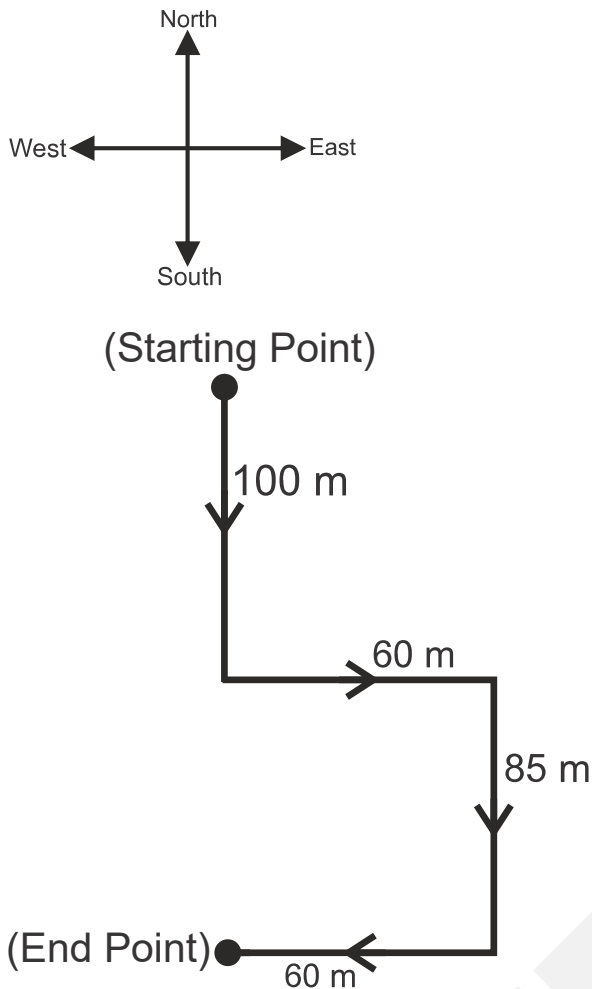

From the above diagram, the distance between her starting point and the endpoint =  $100 + 85 = 185$  m

As she can see her shadow now, that means she is facing the west direction (During the morning, the Sun is in the east direction and the shadow falls on the opposite side of the sun, i.e., the west direction.)

Now, on comparing her movement's direction frame with the general direction frame, it can be concluded that the entry gate of her house is facing the south direction.

So, the entry gate of her house faces the south direction and the distance from her current location to her home is 185 m. Hence, the **first option** is correct.

**Q. 38** **Directions:** Shama, during the time of sunset, started walking towards the opposite side of the sun and then she turned right and right again. What direction is she facing?

**Option 1:**

South

**Option 2:**

West

**Option 3:**

East

**Option 4:**

North

**Correct Answer:**

West

**Solution:**

Firstly, we will draw the direction and distance diagram according to the instructions given in the question -

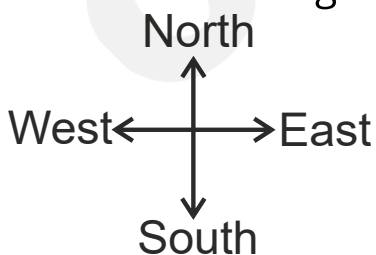

Shama started walking towards the opposite direction of the sun during sunset, i.e., she was walking in the East direction (because during sunset, the sun is in the west direction).

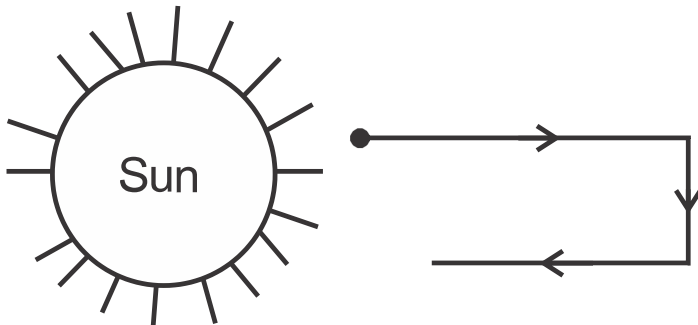

So, Shama is facing the west direction. Hence, the **second option** is correct.

**Q. 39** **Directions:** P started walking from north to south. She turned right at a right angle and then again right at a right angle. In which direction was she ultimately walking?

**Option 1:**  
North

**Option 2:**  
East

**Option 3:**  
South

**Option 4:**  
West

**Correct Answer:**

North

**Solution:**

Firstly, we will draw the direction and distance diagram according to the instructions –

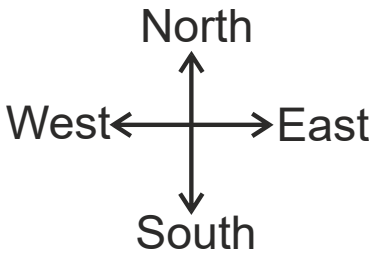

Now, we have to find the direction in which P is moving.

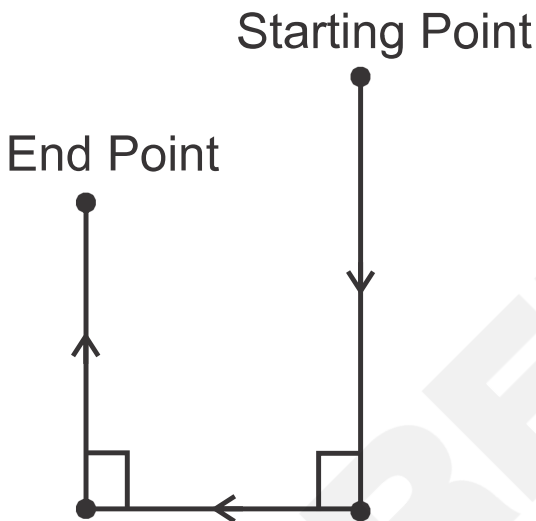

So, P was facing toward the north direction. Hence, the **first option** is correct.

- Q. 40** **Directions:** A man walks 7 km towards the south and turns to the left. After walking 5 km, he turns to the right and walks 7 km. In which direction is he now from the starting point?

**Option 1:**

West

**Option 2:**

South

**Option 3:**

South-East

**Option 4:**

North-East

**Correct Answer:**

South-East

**Solution:**

Firstly, we will draw the diagram according to the instructions given in the question –

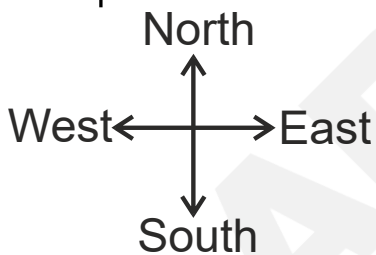

Now, we have to find the direction of the end point from the starting point.

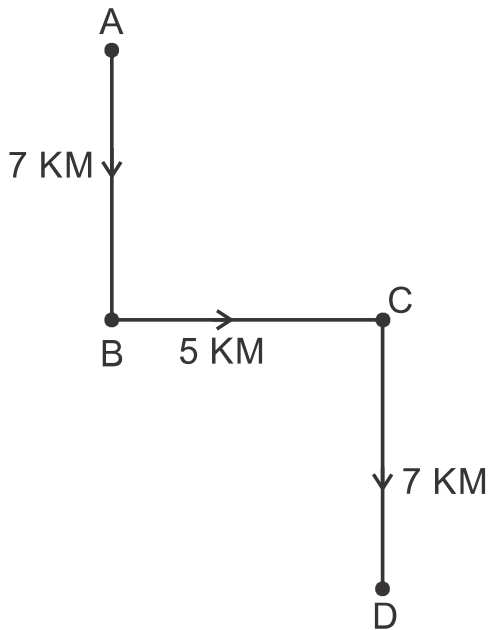

So, he is in the southeast direction from the starting point. Hence, the **third option** is correct.

- Q. 41** **Directions:** Ramesh starts his journey by walking 2 kilometres towards the north. Then he takes a right turn and walks 1 kilometre. Again, takes a right turn and walks 2 kilometres. Now, which direction is he facing?

**Option 1:**

East

**Option 2:**

West

**Option 3:**

South

**Option 4:**

North

**Correct Answer:**

South

**Solution:**

Firstly, we will draw the direction and distance diagram according to the instructions –

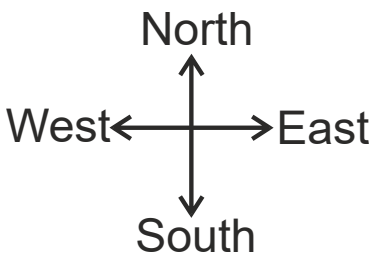

Now, we have to find in which direction Ramesh is facing now.

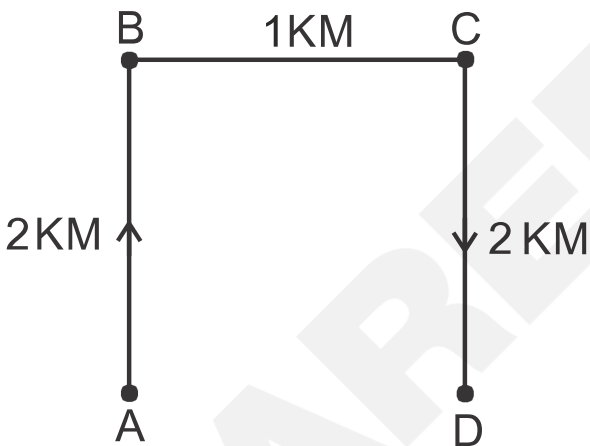

Here, A is the starting point and D is the endpoint.

So, Ramesh is facing the south direction. Hence, the **third option** is correct.

**Q. 42** **Directions:** One morning, Raju walked towards the sun. After some time, he turned left and again to his left. Which direction is he facing?

**Option 1:**

North

**Option 2:**

South

**Option 3:**

East

**Option 4:**

West

**Correct Answer:**

West

**Solution:**

**Given:**

One morning, Raju walked towards the sun, i.e., he walked towards the east direction. (Because in the morning, the Sun is in the east direction.)

Firstly, we will draw the diagram as per the given instructions –

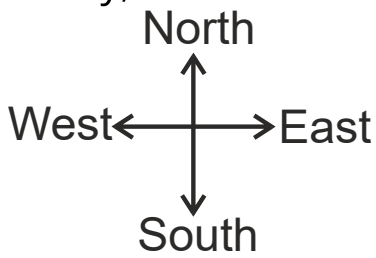

Now, we have to find which direction Raju is facing.

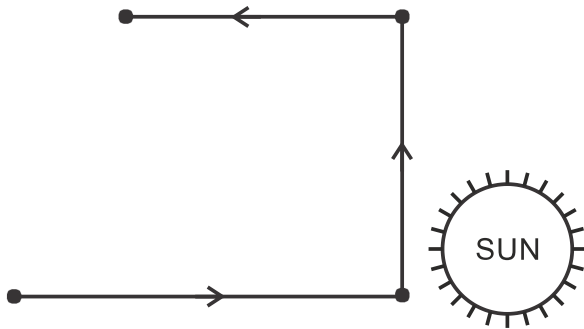

So, Raju is facing towards the west direction. Hence, the **fourth option** is correct.

- Q. 43** **Directions:** John, in the morning, started walking towards the north and then turned towards the opposite side of the sun. He then turns left again and stops. Which direction is he facing now?

**Option 1:**  
North

**Option 2:**  
West

**Option 3:**

South

**Option 4:**

East

**Correct Answer:**

South

**Solution:**

Firstly, we will draw the diagram as per the given instructions –

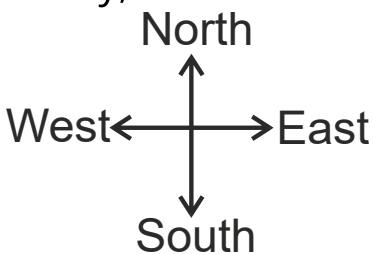

After walking towards the north direction, John turns toward the left direction (As the sun rises in the east direction and the opposite side of the east is west direction.)

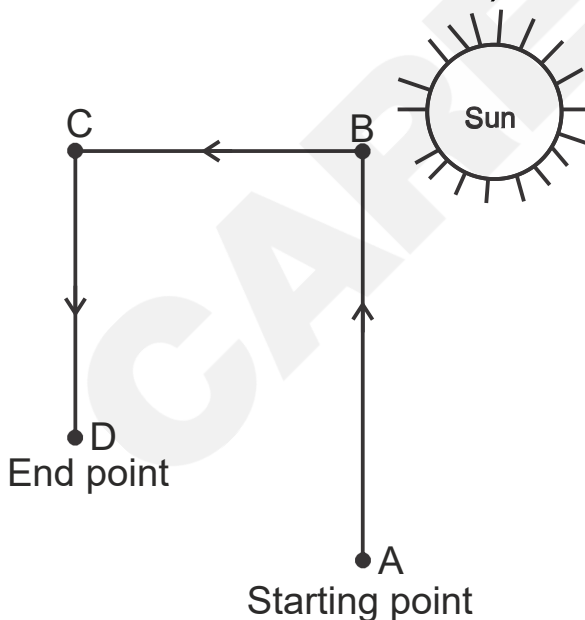

So, John is facing towards the south direction. Hence, the **third option** is correct.

**Q. 44** **Directions:** Ashok went 8 km south turned west and walked 3 km. Again, he turned north and walked 5 km. He took a final turn to the east and walked 3 km. In which direction was Ashok from the starting point?

**Option 1:**

East

**Option 2:**

North

**Option 3:**

West

**Option 4:**

South

**Correct Answer:**

South

**Solution:**

Firstly, we will draw the diagram as per the given instructions –

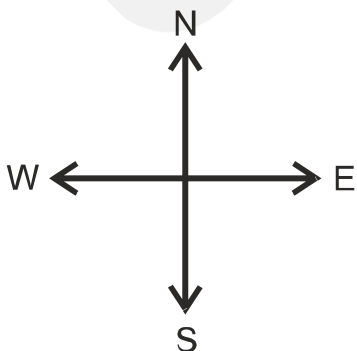

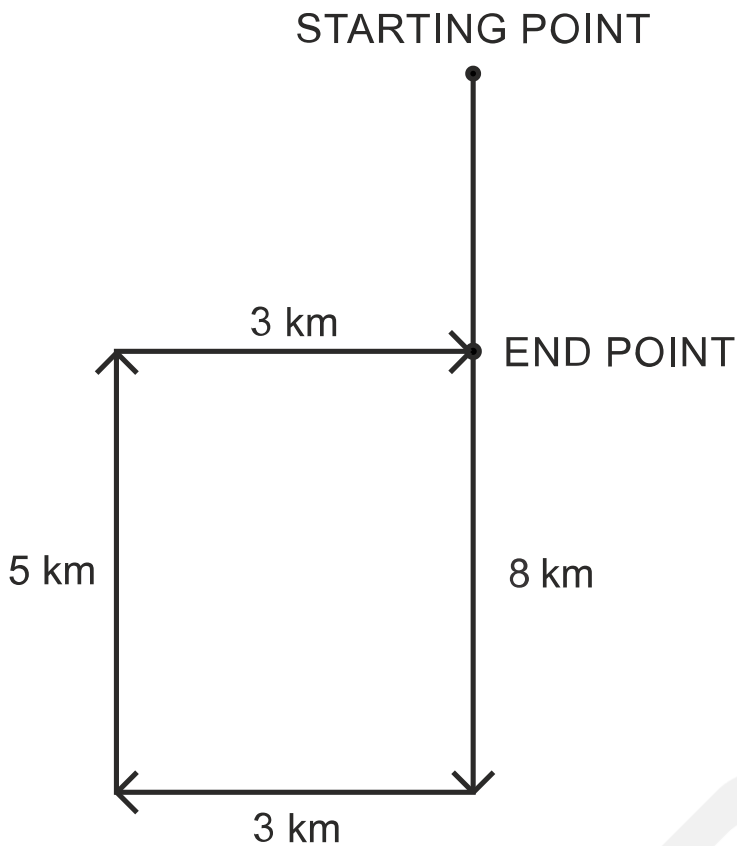

So, Ashok is in the south direction from the starting point. Hence, the **fourth option** is correct.

- Q. 45** **Directions:** Rita travelled 35 km from a point towards the south and then turned left and travelled 20 km and finally turned left again and travelled 35 km. In which direction is she from the starting point?

**Option 1:**

East

**Option 2:**

West

**Option 3:**

North

**Option 4:**

South

**Correct Answer:**

East

**Solution:**

Firstly, we will draw the diagram as per the given instructions –

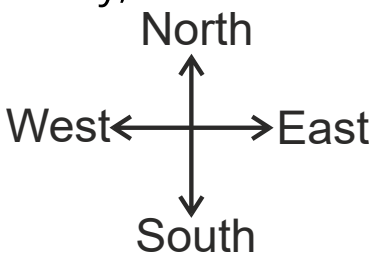

Now, we have to find in which direction is Rita from the starting point.

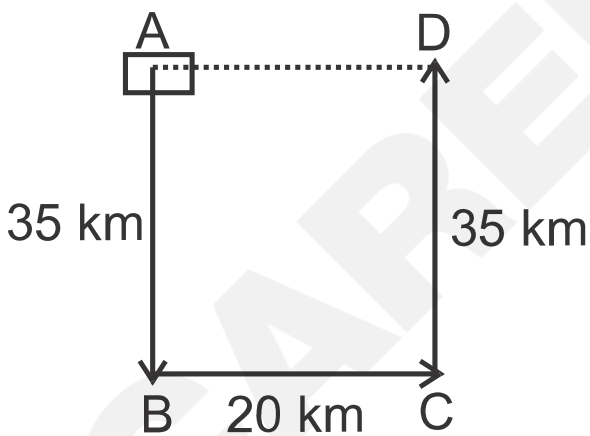

Here A is the starting position and D is the end point.

So, Rita is in the east direction from the starting point. Hence, the **first option** is correct.

**Q. 46** **Directions:** Anitha walked 20 kilometres towards the north. Then she turned right and walked 30 kilometres. Then she turned right and travelled 35 kilometres. Then she moved left and walked 15 kilometres. Finally, she turned left and walked 15 kilometres. In which direction was she going from the starting point?

**Option 1:**  
South

**Option 2:**  
North

**Option 3:**  
East

**Option 4:**  
West

**Correct Answer:**  
East

**Solution:**

Firstly, we will draw the diagram as per the given instructions –

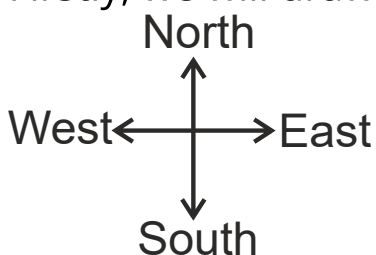

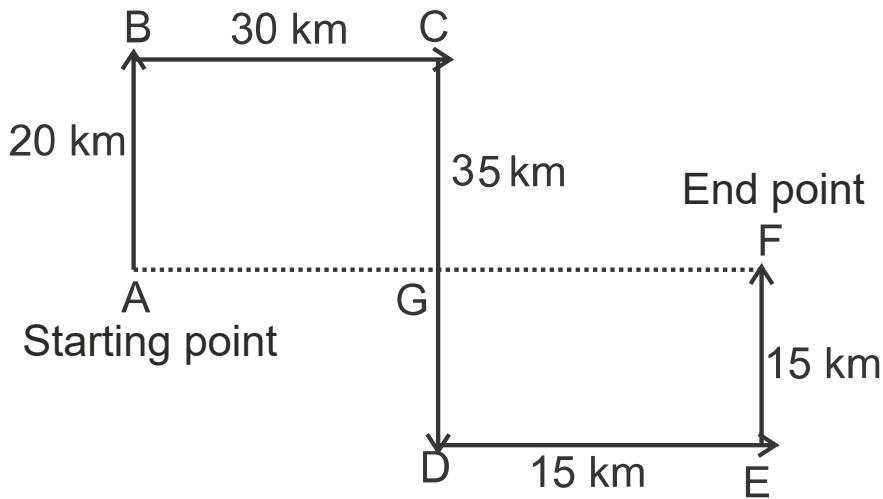

So, Anitha is in the east direction from the starting point. Hence, the **third option** is correct.

- Q. 47** **Directions:** A man walks 5 kilometres towards the south and then turns to the right. After walking 3 kilometres, he turns to the left and walks 5 kilometres. Now in which direction is he from the starting point?

**Option 1:**  
West

**Option 2:**  
South

**Option 3:**  
North-East

**Option 4:**  
South-West

**Correct Answer:**  
South-West

**Solution:**

Firstly, we will draw the diagram as per the given instructions –

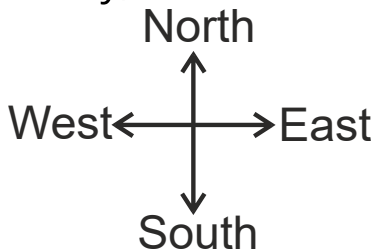

Now, we have to find the direction of man from the starting point.

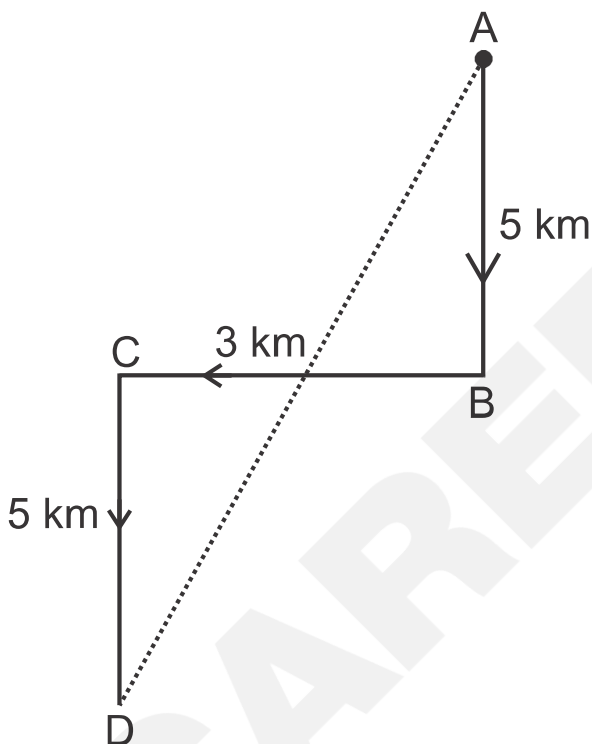

Here, A is the starting point and D is the endpoint.

So, the man is in the southwest direction from the starting point.

Hence, the **fourth option** is correct.

**Q. 48** **Directions:** Rahul starts and walks towards the south and he then turns to his right and walks 5 km, then again turns left and walks 3 km, and then again turns left and walks 5 km. In which direction is he from the starting point?

**Option 1:**  
North

**Option 2:**  
South

**Option 3:**  
East

**Option 4:**  
West

**Correct Answer:**  
South

**Solution:**

Firstly, we will draw the diagram as per the given instructions –

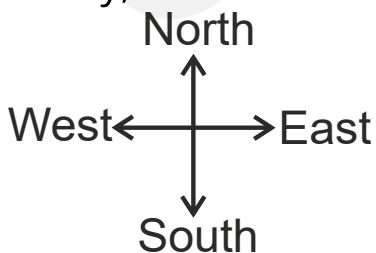

Now, we have to find the direction of Rahul from the starting point.

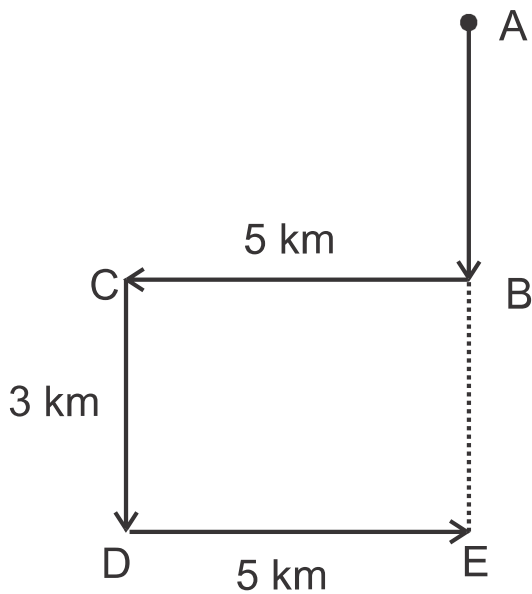

Here, A is the starting point and E is the endpoint.

So, Rahul is in the south direction from the starting point. Hence, the **second option** is correct.

- Q. 49** **Directions:** A person started walking towards the west and covered a distance of 15 m, he turned right and walked 10 m. Again, he turned right and walked 5 m and in the end, he turned left and walked 15 m. Which direction is this person facing now?

**Option 1:**  
North

**Option 2:**  
South

**Option 3:**

East

**Option 4:**

West

**Correct Answer:**

North

**Solution:**

Firstly, we will draw the diagram as per the given instructions –

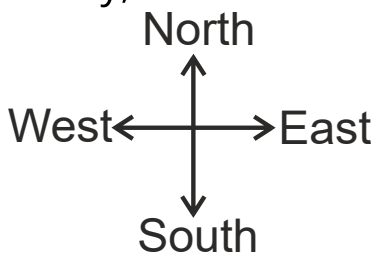

Now, we have to find in which direction the person is facing.

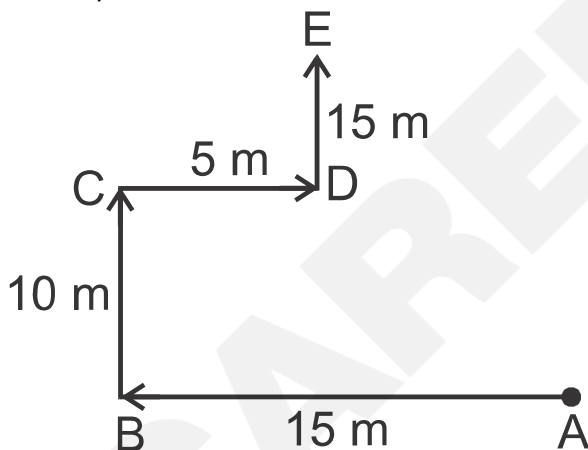

Here, A is the starting point and E is the endpoint.

So, the person is facing in the north direction. Hence, the **first option** is correct.

**Q. 50** **Directions:** If the North is called Northwest, the West is called Southwest, the South is called Southeast and so on. A person walks straight from Southwest to Northeast and then turns left. Walks straight and again turns left. Now what direction he is facing?

**Option 1:**  
South

**Option 2:**  
North-East

**Option 3:**  
North

**Option 4:**  
South-West

**Correct Answer:**  
South-West

**Solution:**

**Given:**

North means Northwest, West means Southwest, South means Southeast, and so on.

Firstly, we will draw the diagram as per the given instructions –

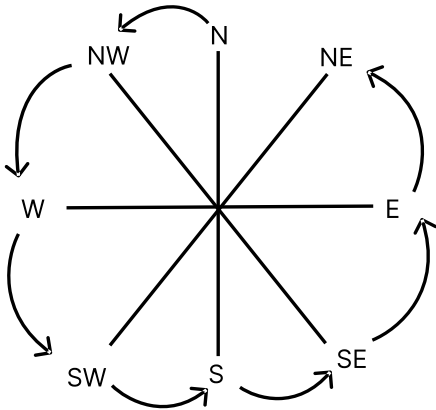
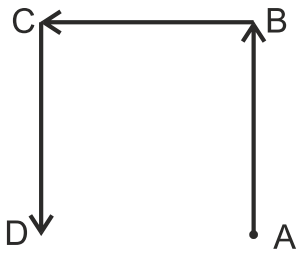

Here, A is the starting point and D is the endpoint.

So, the person is facing in the southwest direction. Hence, the **fourth option** is correct.

- Q. 51** **Directions:** Rajneesh started walking towards north. He took a left turn after walking 20 metres. He again took a right turn after walking 30 metres. Which direction is he facing now?

**Option 1:**  
North

**Option 2:**  
East

**Option 3:**

West

**Option 4:**

South

**Correct Answer:**

North

**Solution:**

Firstly, we will draw the diagram as per the given instructions –

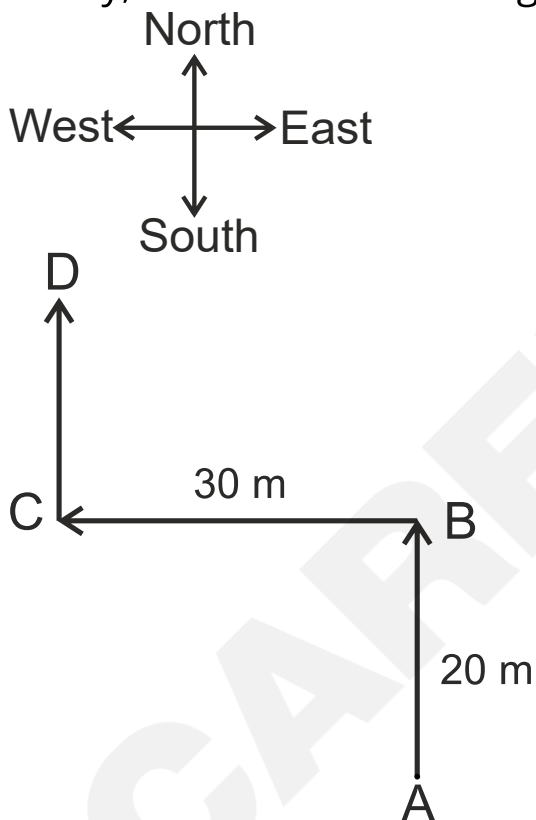

Here, A is the starting point and D is the endpoint.

So, Rajneesh is facing in the north direction. Hence, the **first option** is correct.

**Q. 52** **Directions:** Facing the East, Rahul turned left and walked 10 metres, then he turned to his left again and walked 10 metres. He then turned towards his right and went straight to cover 25 metres. In which direction is he from his starting point?

**Option 1:**  
North-West

**Option 2:**  
North-East

**Option 3:**  
South-West

**Option 4:**  
South-East

**Correct Answer:**  
North-West

**Solution:**

Firstly, we will draw the diagram as per the given instructions –

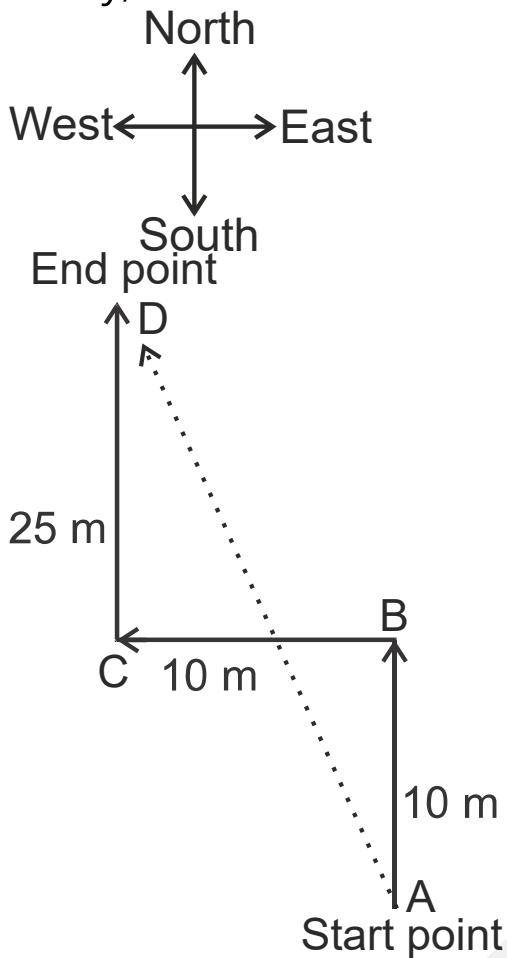

So, Rahul is in the northwest direction from the starting point. Hence, the **first option** is correct.

- Q. 53** **Directions:** Rajesh walks 2 km to the south, then turns northeast and walks 3 km. Then he turns south and walks 2 kilometres. Then he turns west and walks 4 kilometres. Finally, he turns northwest and walks 5 kilometres. In which direction is he going from his starting point?

**Option 1:**

North-West

**Option 2:**

North-East

**Option 3:**

South-East

**Option 4:**

South-West

**Correct Answer:**

North-West

**Solution:**

Firstly, we will draw the diagram as per the given instructions –

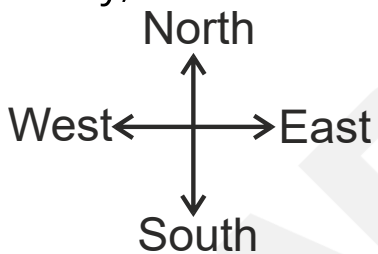

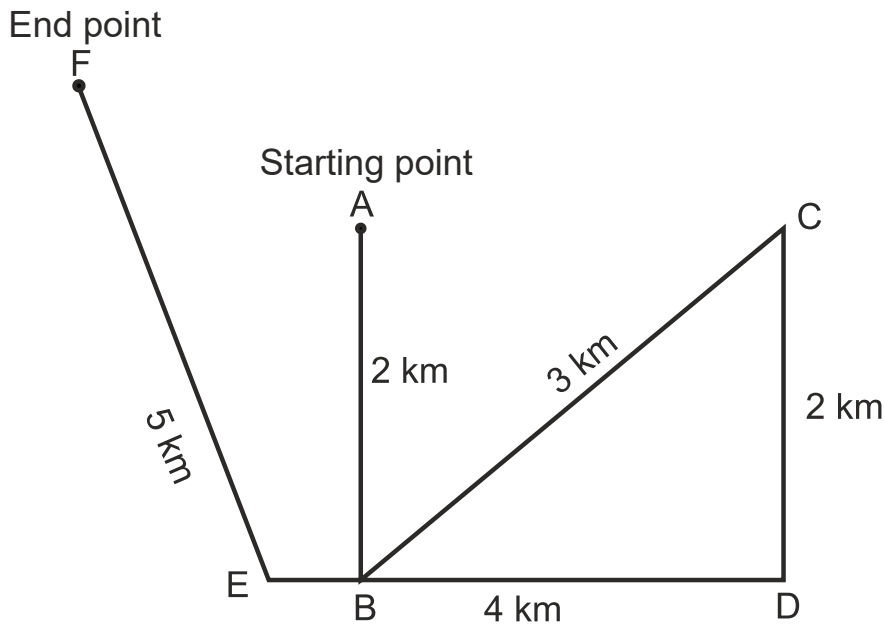

So, Rajesh is in the northwest direction from the starting point. Hence, the **first option** is correct.

- Q. 54** **Directions:** A driver left his village and drove north for 20 kilometres, after which he stopped for breakfast. Then he turned left and drove another 30 km when he stopped for lunch. After some rest, he again turned left and drove 20 km before stopping for evening tea. Once more, he turned left and drove 30 kilometres to reach the town where he had supper. After evening tea, in which direction did he drive?

**Option 1:**

West

**Option 2:**

East

**Option 3:**

North

**Option 4:**

South

**Correct Answer:**

East

**Solution:**

Firstly, we will draw the diagram as per the given instructions –

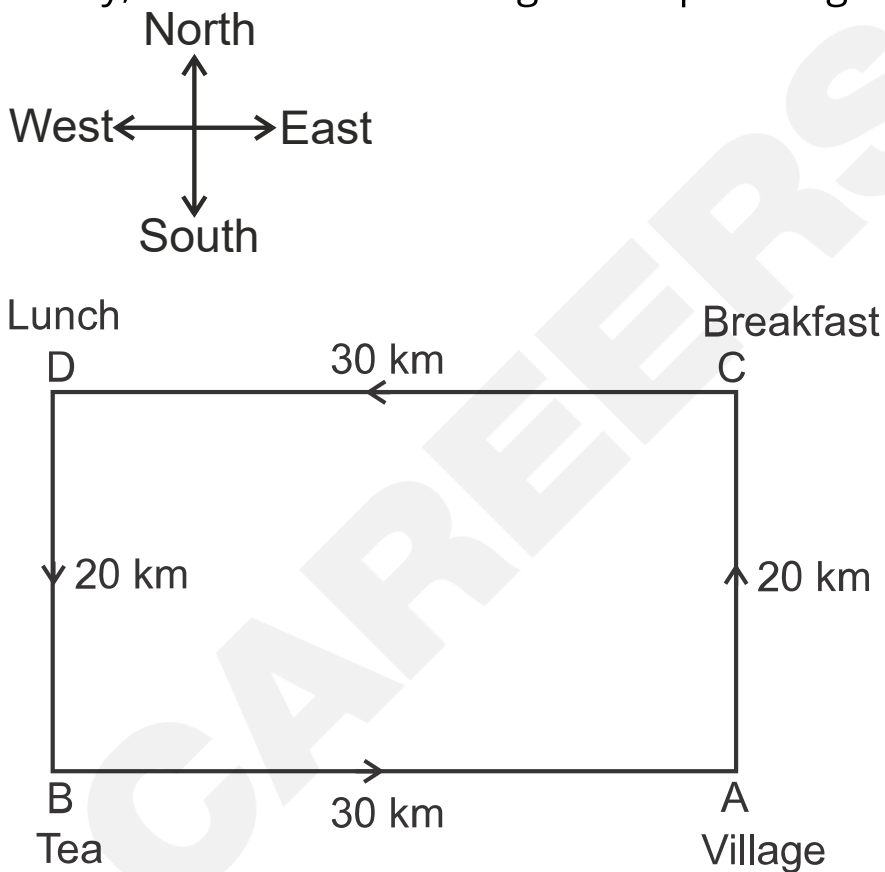

So, the driver is in the east direction. Hence, the **second option** is correct.

**Q. 55** **Directions:** Pranav went 10 kilometres to the north. Then he turned West and covered 10 kilometres. Then he turned south and covered 5 kilometres. Finally, he turned to the east and covered 10 kilometres. In which direction is he from the starting point?

**Option 1:**  
South

**Option 2:**  
North

**Option 3:**  
East

**Option 4:**  
West

**Correct Answer:**  
North

**Solution:**

Firstly, we will draw the diagram as per the given instructions –

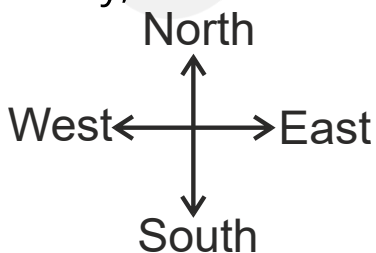

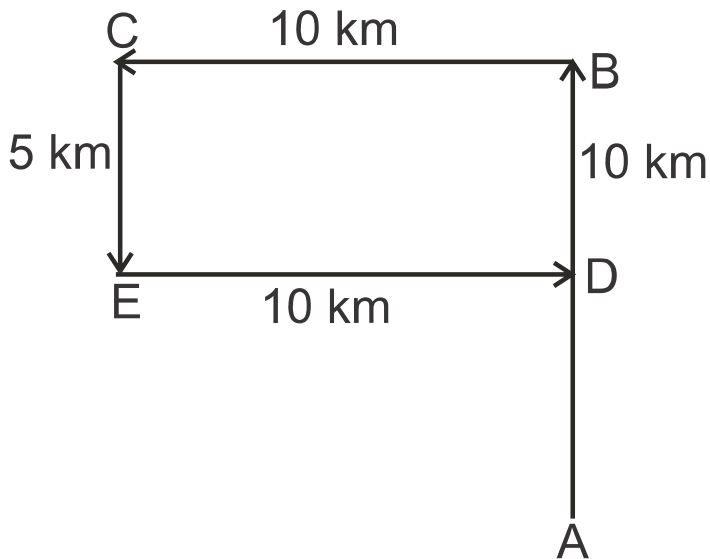

Here, A is the starting point and D is the end point of Pranav.

So, Pranav is in the north direction from the starting point. Hence, the **second option** is correct.

- Q. 56** **Directions:** A boy runs 20 m towards the east and turns to the right; runs 10m and turns to the right and runs 9 m and again turns to the left runs 5 m and turns to the left runs 12 m and finally turns to the left and runs 6 m. Now, which direction is the boy facing?

**Option 1:**  
East

**Option 2:**  
West

**Option 3:**  
North

**Option 4:**

South

**Correct Answer:**

North

**Solution:**

Firstly, we will draw the diagram as per the given instructions –

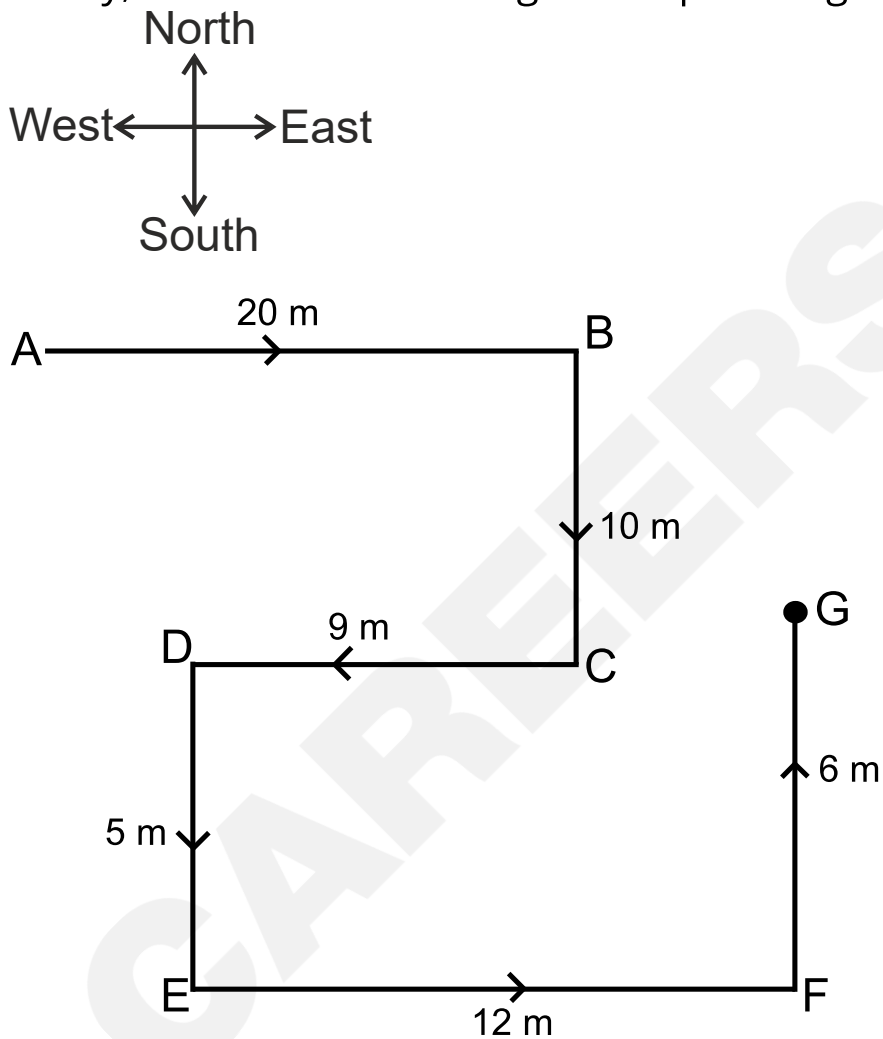

Here, A is the starting point and G is the endpoint.

So, the boy is facing in the north direction. Hence, the **third option** is correct.

**Q. 57** **Directions:** Sanmitra walked 8 m towards the north. He turned to his right and walked 16 m, then he turned to his left and walked 5 m and again he turned to his left and walked 16 m. In which direction is he from his starting point?

**Option 1:**  
South

**Option 2:**  
East

**Option 3:**  
North

**Option 4:**  
West

**Correct Answer:**  
North

**Solution:**

Firstly, we will draw the diagram as per the given instructions –

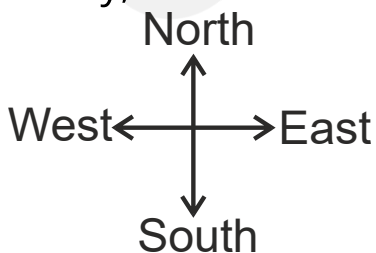

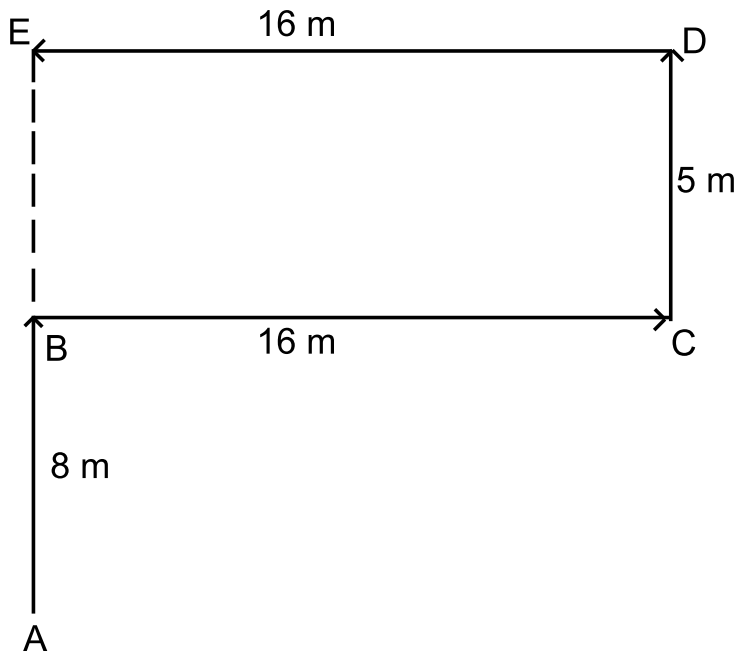

Here, A is the starting point and E is the endpoint.

So, Sanmitra is in the north direction from the starting point. Hence, the **third option** is correct.

---

**Q. 58** **Directions:** If the South-East is changed to North and North-East to West and so on, then what will come in place of South?

**Option 1:**  
South-West

**Option 2:**  
North-East

**Option 3:**  
South-East

**Option 4:**

North-West

**Correct Answer:**

North-East

**Solution:**

From the given information, South-East means North, and North-East means West.

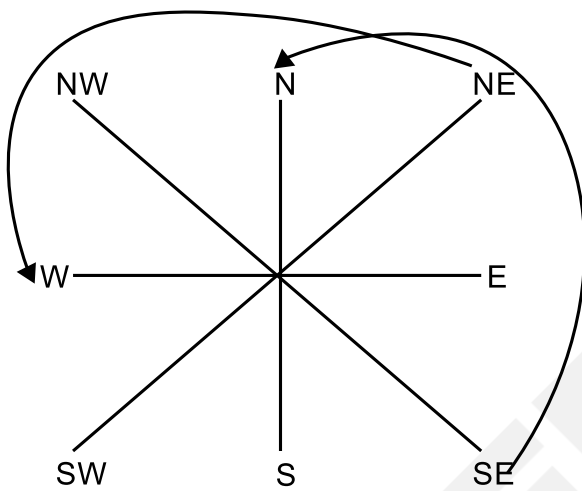

We can see that, to determine the directions need to move 3<sup>rd</sup> steps in a clockwise direction.

So, South means northeast direction. Hence, the **second option** is correct.

- 
- Q. 59 Directions:** A man starts from a point, walks 5 km towards the east, turns right and walks 3 km, turns right again and walks. What is the direction he is facing?

**Option 1:**

North

**Option 2:**

South

**Option 3:**

West

**Option 4:**

South-West

**Correct Answer:**

West

**Solution:**

Firstly, we will draw the diagram as per the given instructions –

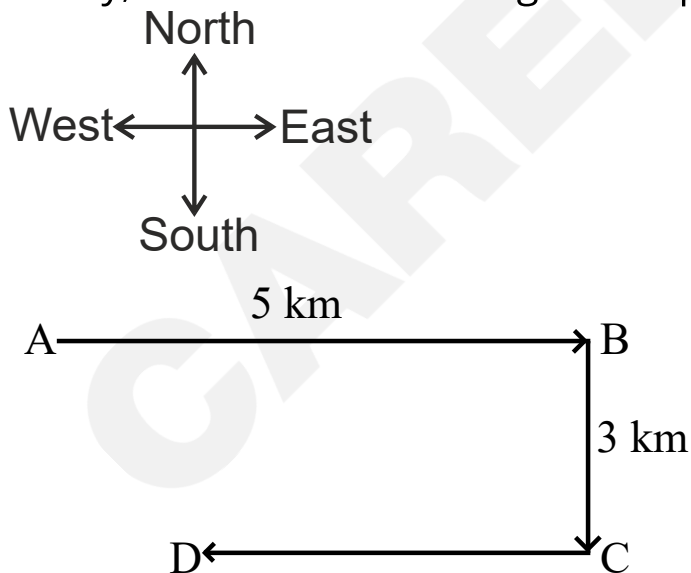

Here, A is the starting point and D is the endpoint.

So, the man is facing in the west direction. Hence, the **third option** is correct.

**Q. 60** **Directions:** From her house, Rimi went 20 km to the north. Then she turned west and covered 15 km. Then she turned south and covered 10 km. Finally turning to the east, she covered 15 km. In which direction is she from her house?

**Option 1:**  
East

**Option 2:**  
West

**Option 3:**  
North

**Option 4:**  
South

**Correct Answer:**  
North

**Solution:**

Firstly, we will draw the diagram as per the given instructions –

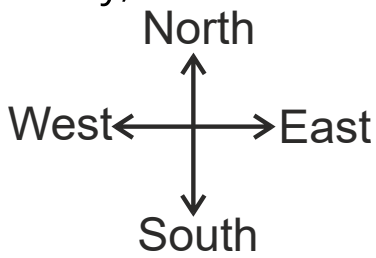

Here, A is the starting point and E is the endpoint in the figure given below.

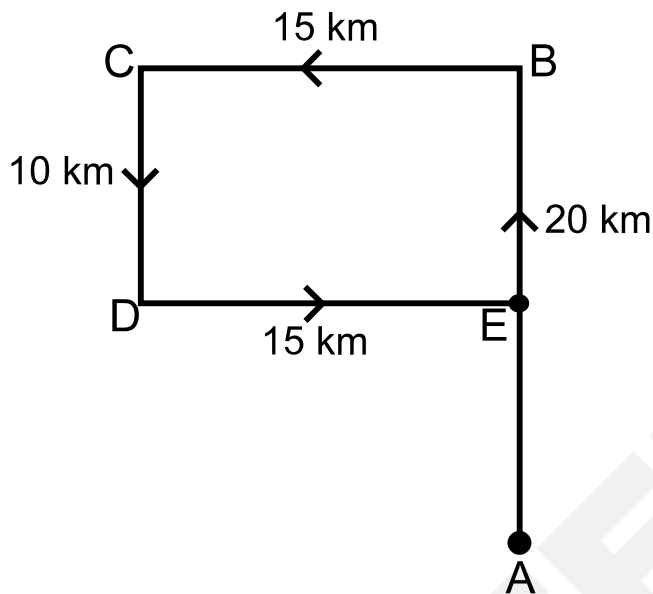

So, Rimi is in the north direction from her house. Hence, the **third option** is correct.

- Q. 61** **Directions:** Seema walks 30 m North. Then she turns right and walks 30 m then she turns right and walks 55 m. Then she turns left and walks 20 m. Then she again turns left and walks 25m. How many metres away is she from her original position?

**Option 1:**

45 m

**Option 2:**

50 m

**Option 3:**

66 m

**Option 4:**

55 m

**Correct Answer:**

50 m

**Solution:**

Firstly, we will draw the diagram as per the given instructions –

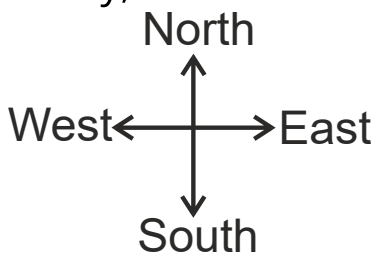

As per the given information, the movement of Seema will look as follows –

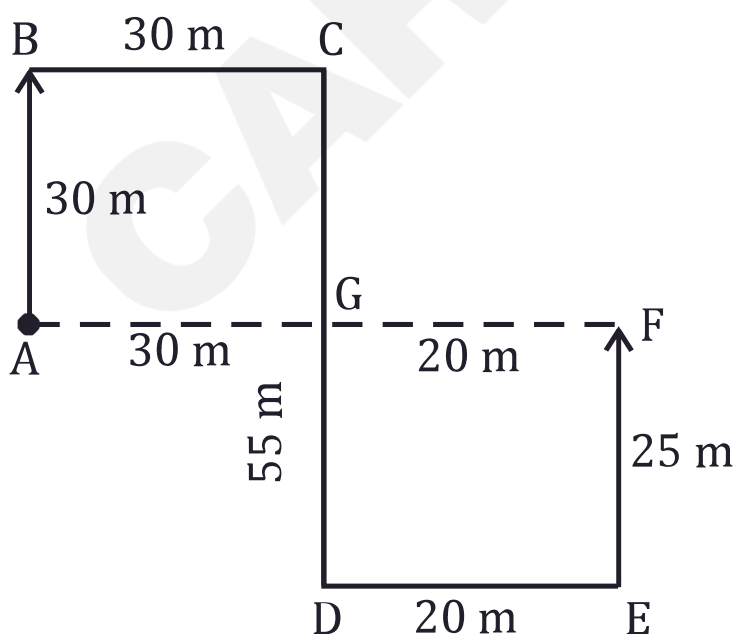

Here, A is the starting point and F is the endpoint. So, AF is the distance from the starting point to the endpoint.

$$AB = BC = AG = 30 \text{ m}$$

$$\text{And, } CD = 55 \text{ m, } DE = GF = 20 \text{ m}$$

$$\text{Now, } AF = AG + GF$$

$$AF = 30 + 20 = 50 \text{ m}$$

So, Seema is 50 m away from her original position. Hence, the **second option** is correct.

---

**Q. 62** **Directions:** Starting from a point O. Mahesh walks a distance of 5 km south, then turns to his right and walks 3 km. From there, he again turns right and walks 5 km. He then turns to his left and walks 5 kilometres. How far is he from the starting point?

**Option 1:**

13 km

**Option 2:**

8 km

**Option 3:**

5 km

**Option 4:**

15 km

**Correct Answer:**

8 km

**Solution:**

As per the given information, the direction and distance diagram is as follows –

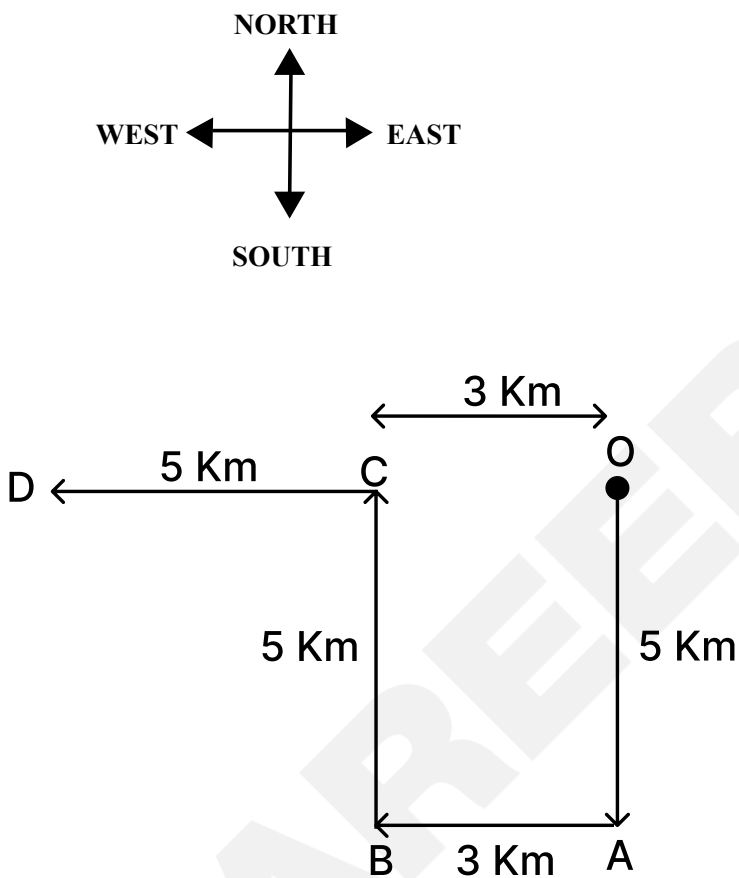

In the above figure, O is the starting point and D is the finishing point.

So, OD is Mahesh's distance from the starting point.

$$OD = OC + CD$$

$$OD = 3 + 5 = 8$$

So, Mahesh is 8 km from the starting point. Hence, the **second option** is correct.

**Q. 63** **Directions:** Rahul walks 30 metres towards the south. Then turning to his right and starts walking straight till he completes another 30 metres. Then again, turning to his left he walks for 20 metres. He then turns to his left and walks for 30 metres. How far is he from his initial position?

**Option 1:**  
50 metres

**Option 2:**  
30 metres

**Option 3:**  
10 metres

**Option 4:**  
60 metres

**Correct Answer:**  
50 metres

**Solution:**

Firstly, we will draw the diagram as per the given instructions –

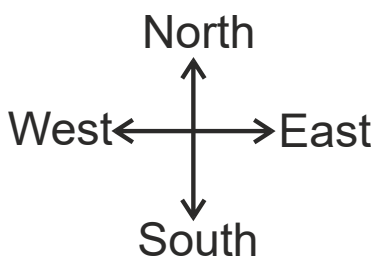

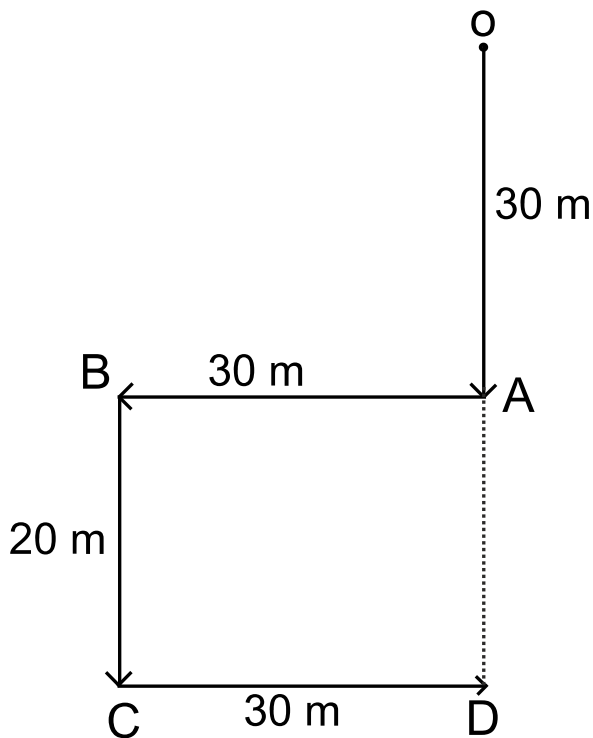

In the above figure, O is the starting point and D is the finishing point. So, OD is the total distance covered by Rahul.

$$OD = OA + AD$$

$$\text{And, } AD = BC = 20 \text{ m}$$

$$\text{Therefore, } OD = 30 + 20 = 50 \text{ m}$$

So, Rahul is 50 metres from the starting point. Hence, the **first option** is correct.

- Q. 64** **Directions:** Ruhi travels 10 km towards the north then turns left and travels 4 km and then again turns right and covers another 5 km and turns right and travels another 4 km. How far is she from the starting point?

**Option 1:**

5 km

**Option 2:**

10 km

**Option 3:**

15 km

**Option 4:**

20 km

**Correct Answer:**

15 km

**Solution:**

Firstly, we will draw the diagram as per the given instructions –

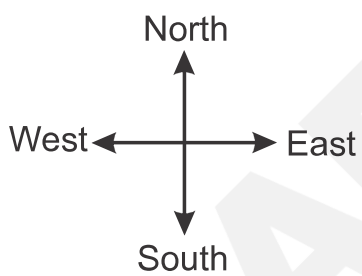

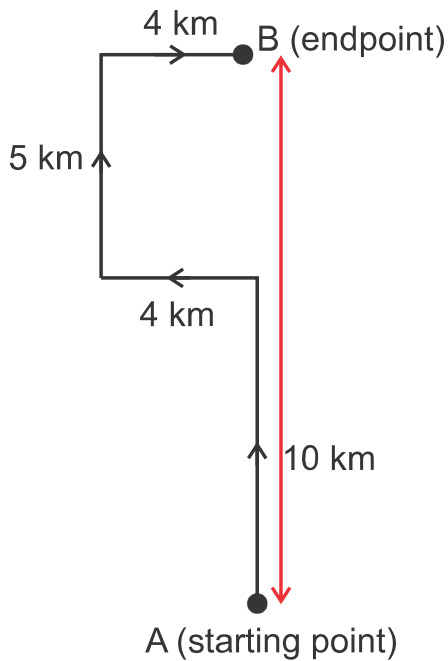

From the above diagram, the distance between the starting and the endpoint is 15 km.

So, Ruhi is at a distance of 15 km from the starting point. Hence, the **third option** is correct.

- Q. 65** **Directions:** Anushka starts from point L and walks 10 m towards the north. She then turns to her right and walks 5 m. Again she turns to her left and walks 10 m and then she takes one more left turn of 5 m up to point M. How far is she from her starting point?

**Option 1:**  
5 m

**Option 2:**

20 m

**Option 3:**

25 m

**Option 4:**

30 m

**Correct Answer:**

20 m

**Solution:**

Firstly, we will draw the diagram as per the given instructions –

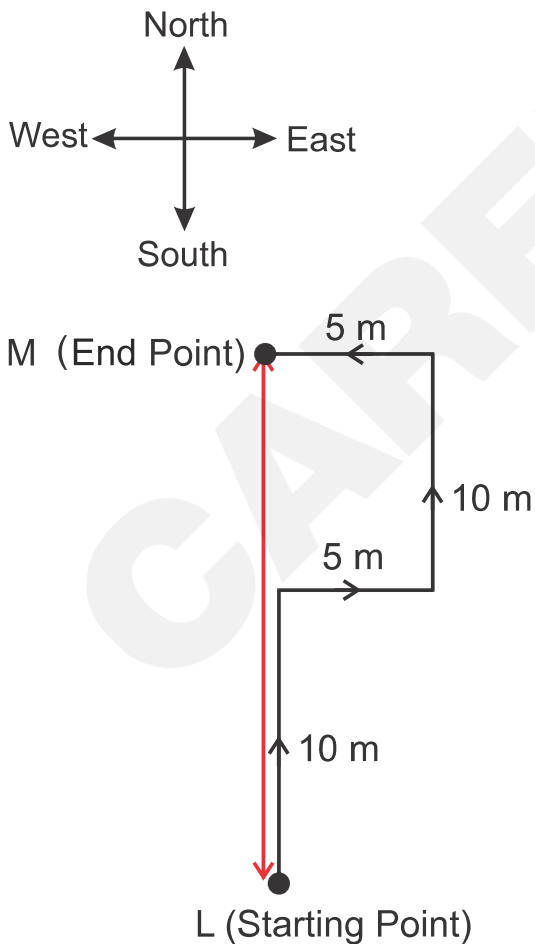

From the above diagram, the distance between the starting and the endpoint is 20 m.

So, Anushka is at a distance of 20 m from the starting point. Hence, the **second option** is correct.

**Q. 66** **Directions:** M starts from his office and goes 15 km southwards, he then travels 5 km to the right, then travels 7 km to the left, and again he travels 7 km to the left, and eventually goes 22 km towards the left. Measure the distance between the final and starting point.

**Option 1:**

3 km

**Option 2:**

2 km

**Option 3:**

1 km

**Option 4:**

4 km

**Correct Answer:**

2 km

**Solution:**

Firstly, we will draw the diagram as per the given instructions –

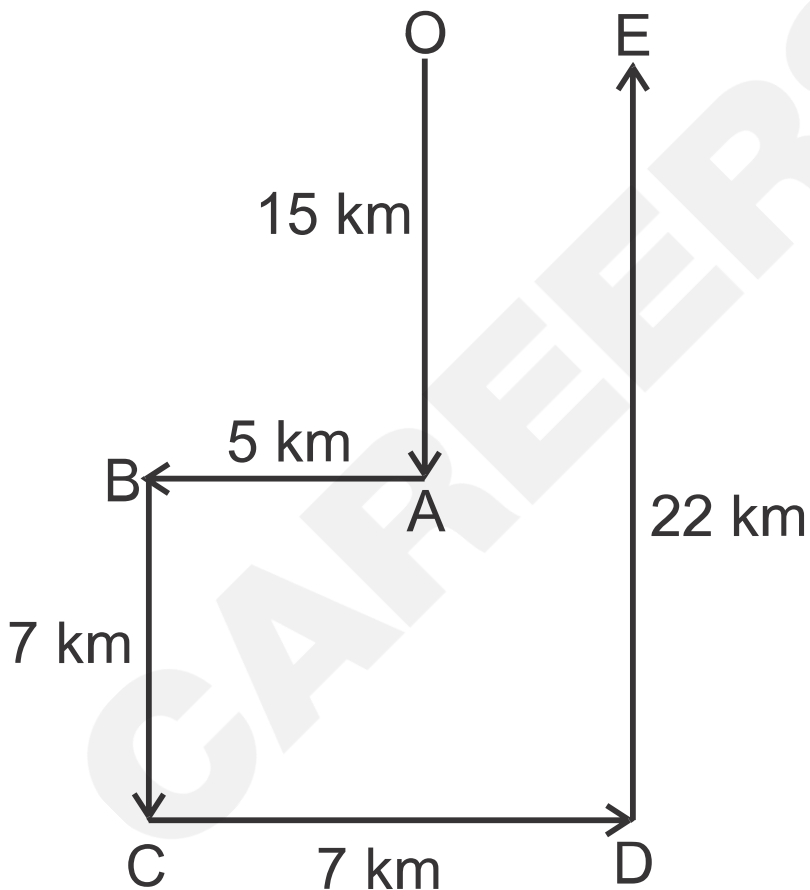
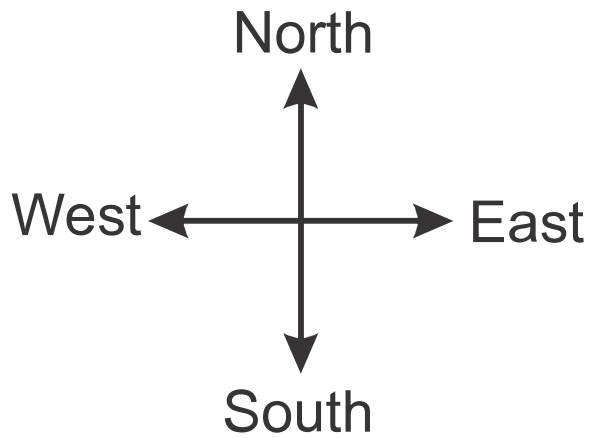

In the above figure, O is the starting point and E is the finishing point. So, OE is M's distance from the starting point to the final point.  
 $OE = CD - AB$

$$OE = 7 - 5 = 2 \text{ km}$$

So, M's distance from the starting point to the final point is 2 km.  
Hence, the **second option** is correct.

**Q. 67** **Directions:** A goes 7 km eastward, then turns right and proceeds 7 km. Then travels 15 km towards left, then travels 12 km towards left, and finally goes 5 km northward. Calculate his distance from his initial place in the horizontal direction.

**Option 1:**

20 km

**Option 2:**

22 km

**Option 3:**

23 km

**Option 4:**

25 km

**Correct Answer:**

22 km

**Solution:**

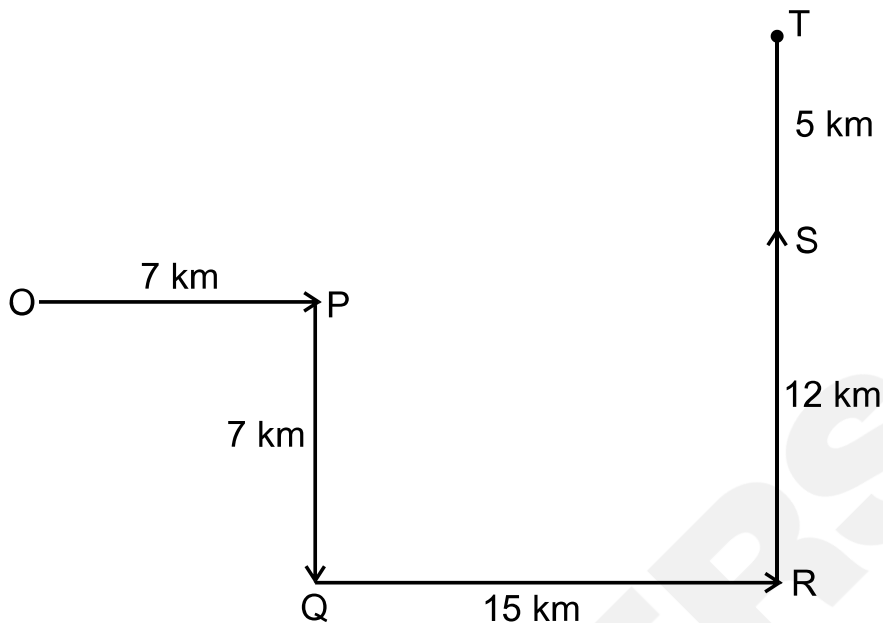
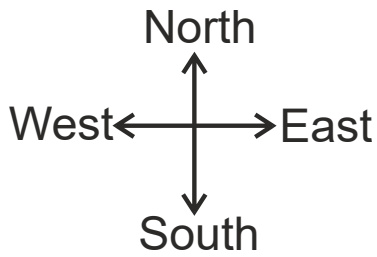

In the above figure, O is the starting point and T is the finishing point. A's distance from his initial place in the horizontal direction is (OP + QR).

$$OP + QR = 7 + 15 = 22 \text{ km}$$

So, A is 22 km from the starting point in the horizontal direction.

Hence, the **second option** is correct.

**Q. 68** **Directions:** Deepak starts walking straight towards the east. After walking 75 metres, he turns to the left and walks 25 metres straight. Again he turns to the left and walks a distance of 40 metres straight, again he turns to the left and walks a distance of 25 metres. How far is he from the starting point?

**Option 1:**  
35 m

**Option 2:**  
50 m

**Option 3:**  
115 m

**Option 4:**  
140 m

**Correct Answer:**  
35 m

**Solution:**

Firstly, we will draw the diagram as per the given instructions –

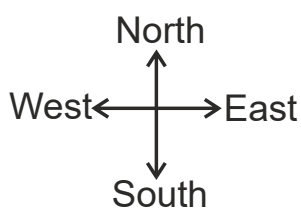

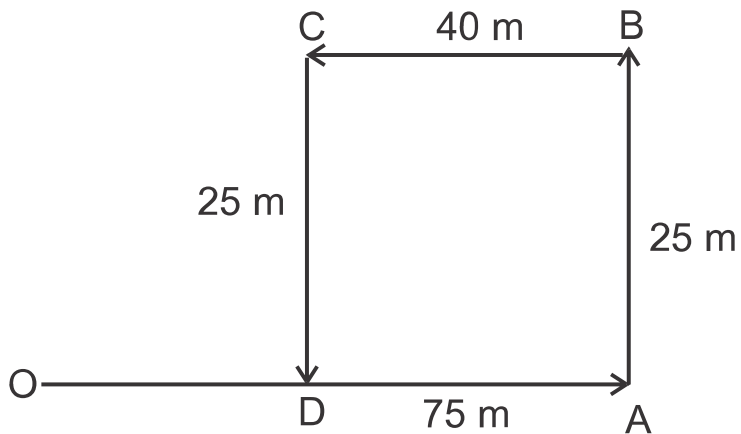

In the above figure, O is the starting point and D is the finishing point. So, OD is Deepak's distance from the starting point.

$$OD = OA - AD$$

$$\text{But, } AD = BC = 40$$

$$OD = 75 - 40 = 35$$

So, Deepak is 35 metres from the starting point. Hence, the **first option** is correct.

**Q. 69** **Directions:** I walk 12 km to the North, then 10 kilometres East, and then 12 km south. How far am I from the starting point?

**Option 1:**  
34 km

**Option 2:**  
24 km

**Option 3:**

22 km

**Option 4:**

10 km

**Correct Answer:**

10 km

**Solution:**

Firstly, we will draw the diagram as per the given instructions –

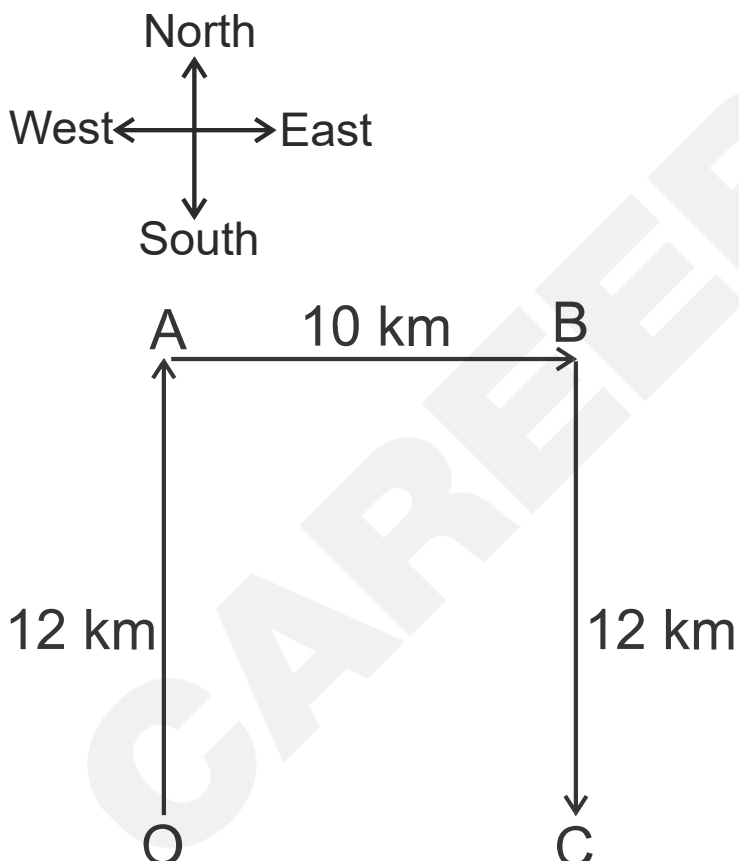

In the above figure, O is the starting point and C is the finishing point. So, OC is the distance from the starting point. Here,  $OC = AB = 10$  km.

So, I am 10 km far from my starting point. Hence, the **fourth option** is correct.

**Q. 70** **Directions:** Seeta and Ram both start from a point toward the North. Seeta turns to the left after walking 10 km. Ram turns to the right after walking the same distance. Seeta waits for some time and then walks another 5 km, whereas Ram walks only 3 km. They both then turn to their respective south and walk 15 km forward. How far is Seeta from Ram?

**Option 1:**  
8 km

**Option 2:**  
12 km

**Option 3:**  
15 km

**Option 4:**  
10 km

**Correct Answer:**  
8 km

**Solution:**

Firstly, we will draw the diagram as per the given instructions –

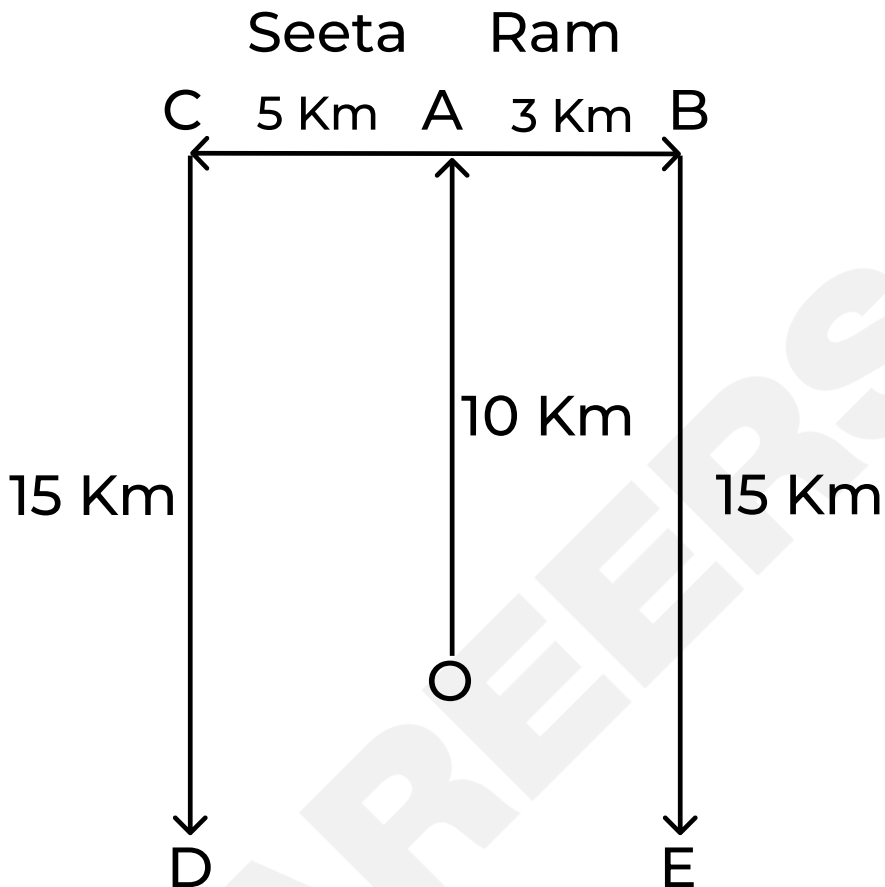
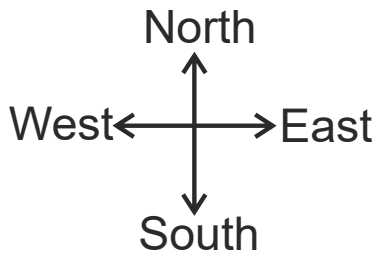

In the above figure, O is the starting point for both, D is the finishing point for Seeta and E is the finishing point for Ram. So, DE is the distance between Sita and Ram.

Here,  $DE = BC$

$$BC = CA + AB = 5 + 3 = 8$$

So, Sita and Ram are 8 km from each other. Hence, the **first option** is correct.

**Q. 71** **Directions:** A man starts from a point, moves 9 km south, then turns east and goes 3 km. He turns south and walks 3 km, and then moves 8 km towards the west. How far is he from the starting point?

**Option 1:**

15 km

**Option 2:**

12 km

**Option 3:**

11 km

**Option 4:**

13 km

**Correct Answer:**

13 km

**Solution:**

Firstly, we will draw the diagram as per the given instructions in the question.

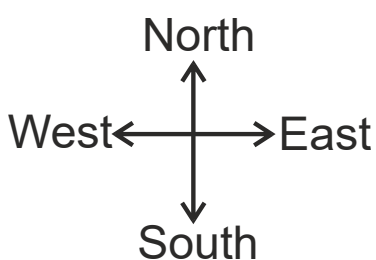

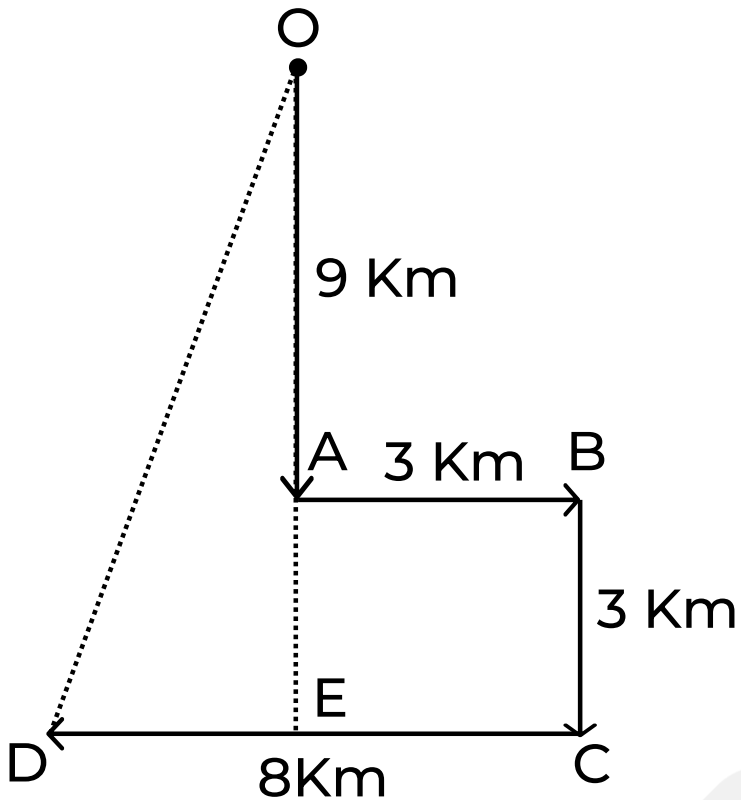

In the above figure, O is the starting point and D is the finishing point.

So, OD is the distance from the starting point.

OD can be found using Pythagoras theorem.

$$OD^2 = OE^2 + DE^2$$

$$OE = OA + AE = 9 + 3 = 12$$

$$DE = CD - CE = CD - AB = 8 - 3 = 5$$

$$\text{So, } OE^2 + DE^2 = 12^2 + 5^2 = 144 + 25 = 169$$

$$OD = (169)^{1/2} = 13$$

So, the distance from the starting point is 13 km. Hence, the **fourth option** is correct.

**Q. 72** **Directions:** A bus starts from point A and runs 20 km towards the south, then turns to its right and runs 25 km. It then turns right again and runs 20 km. Afterwards, it runs 5 km in the east direction and reaches point D. How far is the bus from the starting point?

**Option 1:**  
35 km

**Option 2:**  
20 km

**Option 3:**  
25 km

**Option 4:**  
30 km

**Correct Answer:**  
20 km

**Solution:**

Firstly, we will draw the diagram as per the given instructions in the question –

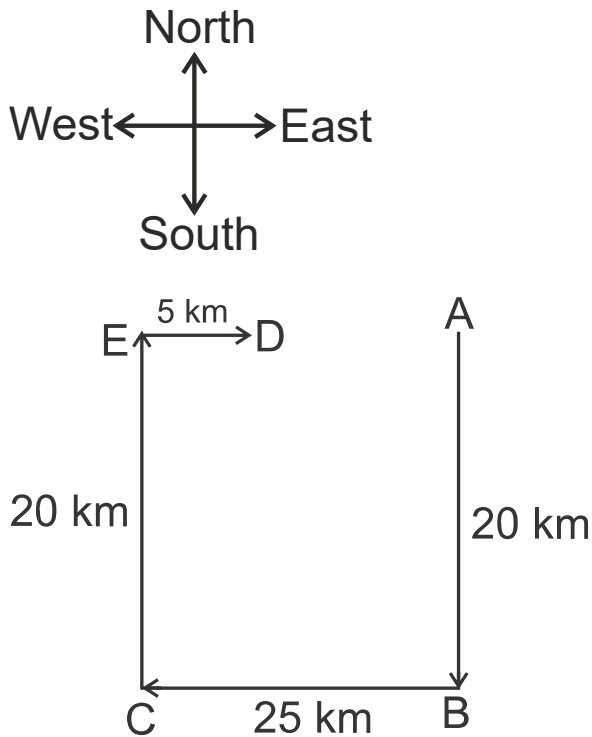

In the above figure, A is the starting point and D is the endpoint. So, AD is the required distance from the starting point.

$$AD = AE - ED$$

$$\text{But, } AE = BC = 25$$

$$AD = 25 - 5 = 20 \text{ km}$$

So, the bus is 20 km from the starting point. Hence, the **second option** is correct.

- Q. 73** **Directions:** A man goes 10 km westward, then turns right and proceeds 4 km, then travels 10 km towards left, then travels 8 km towards left, and finally goes 4 km northward. Calculate his distance from his initial place in the horizontal direction.

**Option 1:**

20 km

**Option 2:**

22 km

**Option 3:**

23 km

**Option 4:**

25 km

**Correct Answer:**

20 km

**Solution:**

Firstly, we will draw the diagram as per the given instructions –

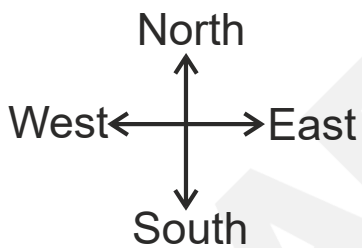

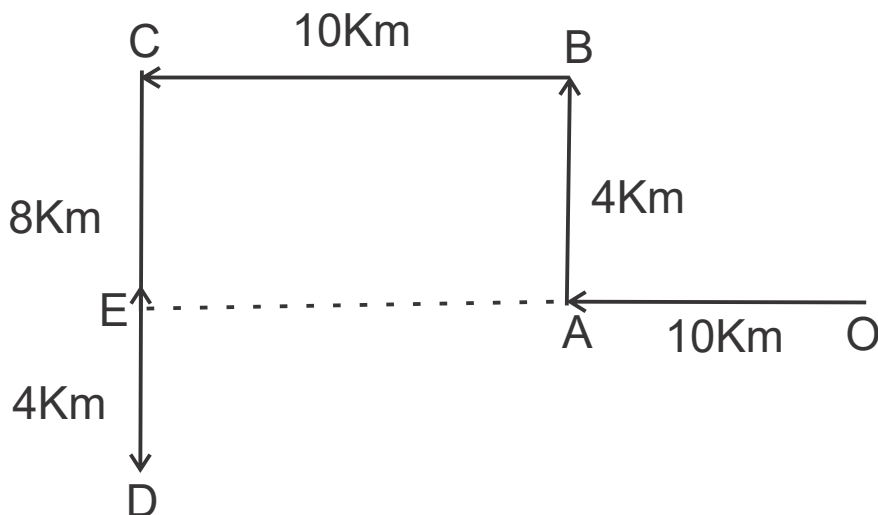

In the above figure, O is the starting point and E is the finishing point. So, OE is the distance from the starting point.

$$OE = OA + AE$$

$$\text{Also, } AE = BC = 10$$

$$OE = 10 + 10 = 20 \text{ km}$$

So, the distance from the starting point is 20 km. Hence, the **first option** is correct.

- Q. 74** **Directions:** Ram walks 3 km towards the east, takes a left turn, and walks for 1 km before he turns left and walks 2 km to take another left turn to walk for another 1 km. How many km is he away from his starting point?

**Option 1:**

1 km

**Option 2:**

2 km

**Option 3:**

3 km

**Option 4:**

4 km

**Correct Answer:**

1 km

**Solution:**

Firstly, we will draw the diagram as per the given instructions –

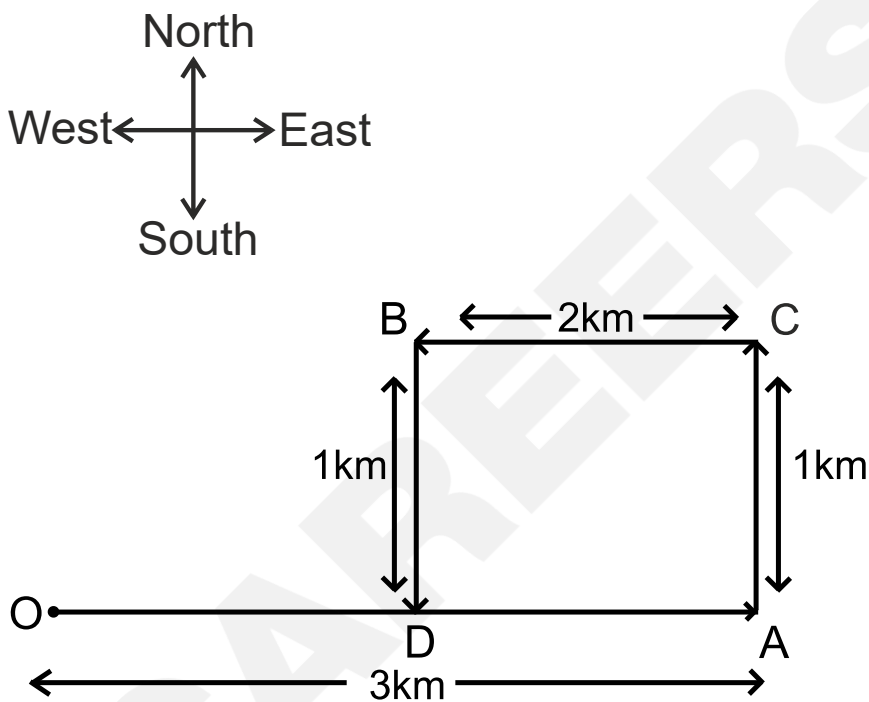

In the above figure, O is the starting point and D is the finishing point.

So, OD is the distance from the starting point.

$$OD = OA - AD$$

$$\text{And, } AD = BC = 2 \text{ km}$$

$$\text{Therefore, } OD = 3 - 2 = 1 \text{ km}$$

So, Ram is 1 km away from his starting point. Hence, the **first option** is correct.

**Q. 75** **Directions:** X walked 20 feet from A to B in the east direction. Then, X turned to the right and walked 6 feet. Again, X turned to the right and walked 28 feet. How far is X from A?

**Option 1:**

28

**Option 2:**

9

**Option 3:**

10

**Option 4:**

27

**Correct Answer:**

10

**Solution:**

Firstly, we will draw the diagram as per the given instructions –

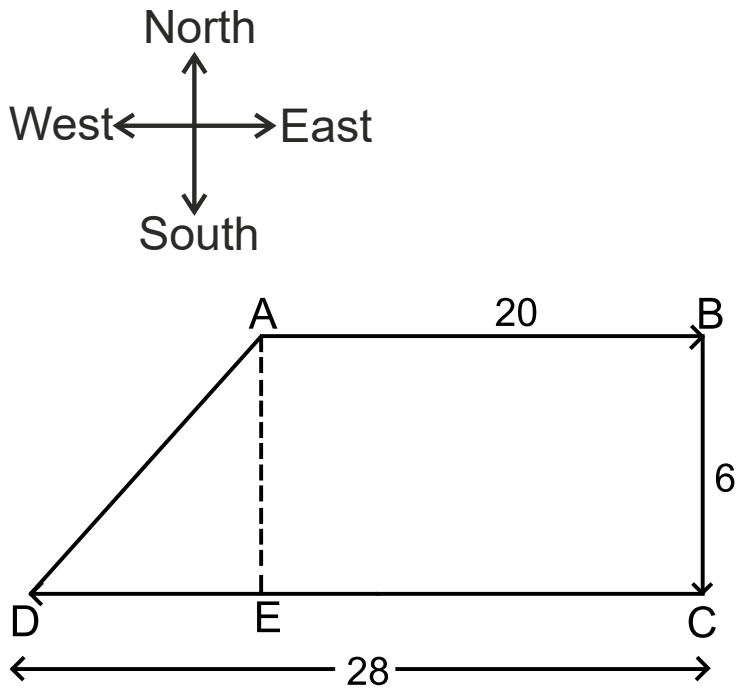

In the above figure, A is the starting point and D is the endpoint. So, AD is the distance between the starting point and the endpoint.

$$AE = BC = 6 \text{ feet}$$

$$DE = CD - CE = 28 - 20 = 8 \text{ feet}$$

By using Pythagoras' theorem in triangle AED -

$$AD^2 = DE^2 + AE^2$$

$$AD^2 = 8^2 + 6^2$$

$$AD^2 = 64 + 36$$

$$AD^2 = 100$$

$$AD = 10 \text{ feet}$$

So, the distance from the starting point is 10 feet. Hence, the **third option** is correct.

**Q. 76** **Directions:** Ram went 20 metres to the north, then turned towards the east and walked another 5 metres. Then, he turned towards the right and covered 20 metres. How far is he from the starting point?

**Option 1:**

3 m

**Option 2:**

4 m

**Option 3:**

5 m

**Option 4:**

6 m

**Correct Answer:**

5 m

**Solution:**

Firstly, we will draw the diagram as per the given instructions –

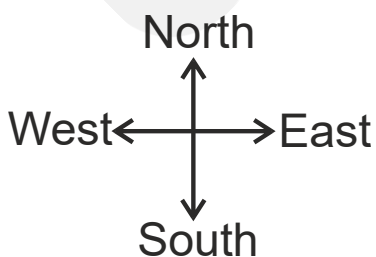

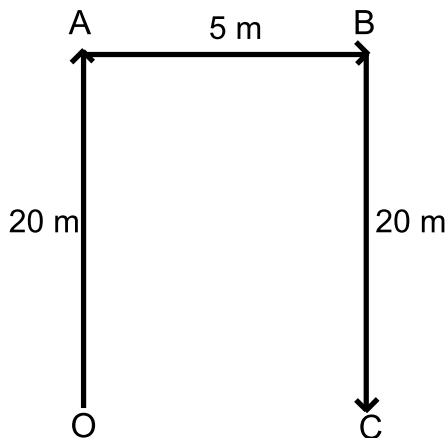

In the above figure, O is the starting point and C is the finishing point. So, OC is the distance from the starting point.

$OC = AB = 5$  metres

So, he is 5 metres far from the starting point. Hence, the **third option** is correct.

**Q. 77**

**Directions:** Sham goes to his friend's house, which is straight 10 km from his house. On his way back, he takes a right turn and walks 2 km, then again takes a right turn and walks for 10 km before taking a right turn again. How much distance is Sham still away from his house?

**Option 1:**

10 km

**Option 2:**

8 km

**Option 3:**

12 km

**Option 4:**

2 km

**Correct Answer:**

2 km

**Solution:**

Firstly, we will draw the diagram as per the given instructions –

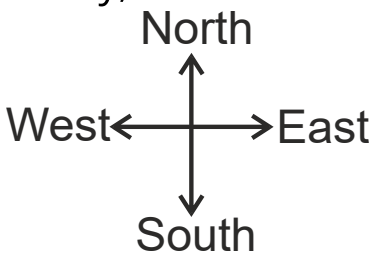

Let Sham's friend's house is in the north direction. Now, draw the diagram as per the given instructions –

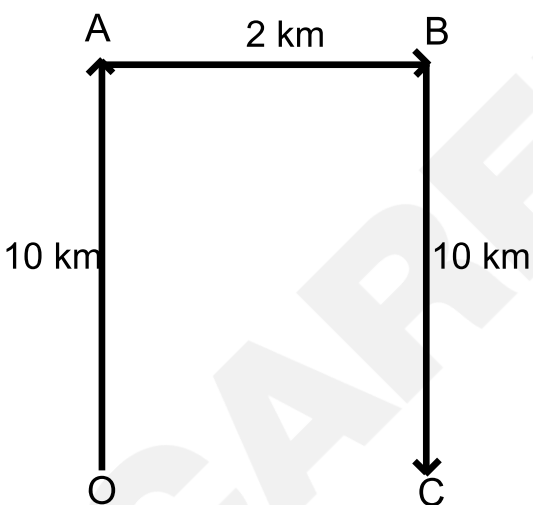

In the above figure, O is the starting point and C is the finishing point. So, OC is the distance from the starting point.

$$OC = AB = 2 \text{ km}$$

So, the distance from the starting point is 2 km. Hence, the **fourth option** is correct.

**Q. 78** **Directions:** A girl walks 30 metres towards the south, then turns to her right and walks 30 metres, then turns to her left and walks 20 metres, then again turns to her left and walks 30 metres. How far is she from her initial position?

**Option 1:**  
20 metres

**Option 2:**  
30 metres

**Option 3:**  
50 metres

**Option 4:**  
60 metres

**Correct Answer:**  
50 metres

**Solution:**

Firstly, we will draw the diagram as per the given instructions –

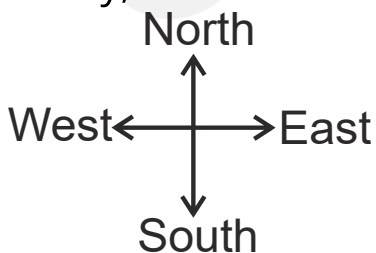

Now, we have to find the distance between starting and endpoints.

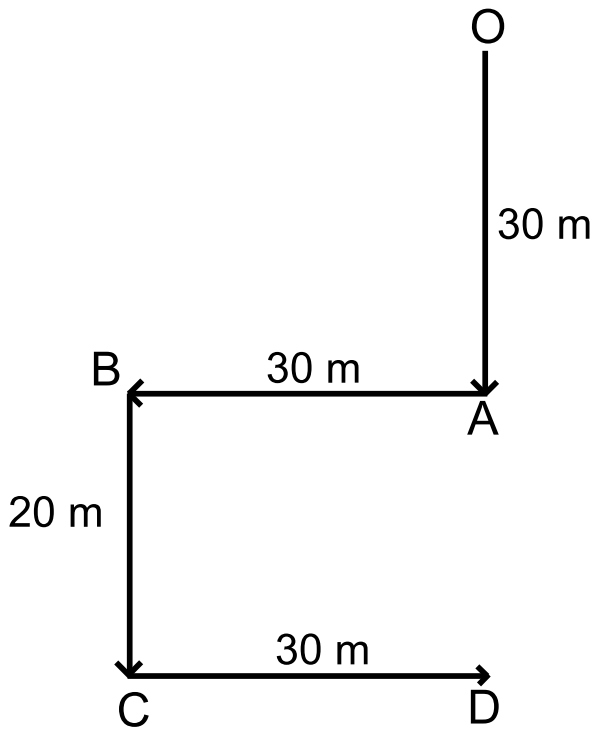

In the above figure, O is the starting point and D is the finishing point. So, OD is the distance from the starting point.

$$OD = OA + AD \quad (AD = BC = 20 \text{ m})$$

$$OD = 30 + 20 = 50 \text{ m}$$

So, the distance from the starting point is 50 metres. Hence, the **third option** is correct.

- Q. 79** **Directions:** Rama walked 10 km south, turned right, and walked 5 km. Then again, she turned right and walked 10 km. Then she turned left and walked 10 km. How many km will Rama have to walk to reach the starting point?

**Option 1:**  
25 km

**Option 2:**

20 km

**Option 3:**

5 km

**Option 4:**

15 km

**Correct Answer:**

15 km

**Solution:**

Firstly, we will draw the diagram as per the given instructions –

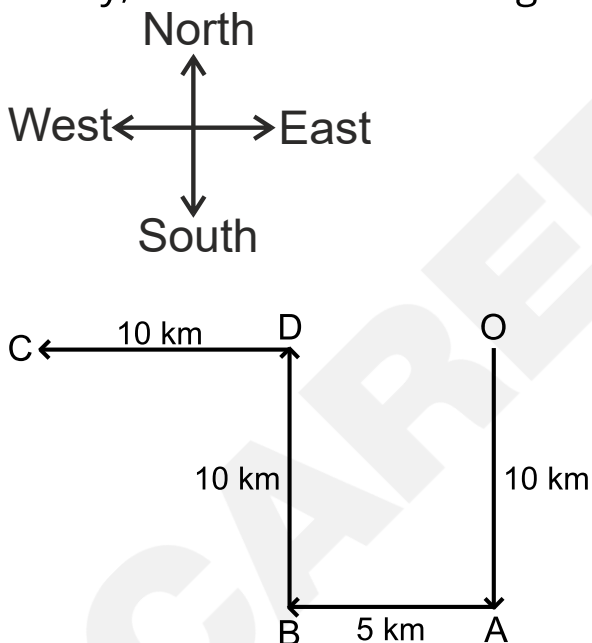

In the above figure, O is the starting point and C is the finishing point.

So, OC is the distance from the starting point.

$$OC = OD + DC$$

$$\text{And, } OD = AB = 5 \text{ km}$$

$$OC = 10 + 5 = 15 \text{ km}$$

So, to reach the starting point Rama has to walk 15 km. Hence, the **fourth option** is correct.

**Q. 80** **Directions:** Prem starts to walk to school from his house and walks 400 metres to the north turns left and walks 100 metres; turns left and walks 200 metres and then turns left and walks 100 metres. How far is he away from his house?

**Option 1:**  
100 metres

**Option 2:**  
300 metres

**Option 3:**  
200 metres

**Option 4:**  
250 metres

**Correct Answer:**  
200 metres

**Solution:**

Firstly, we will draw the diagram as per the given instructions –

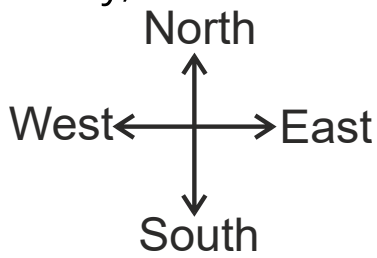

Now, we have to find the distance between the house and the endpoint.

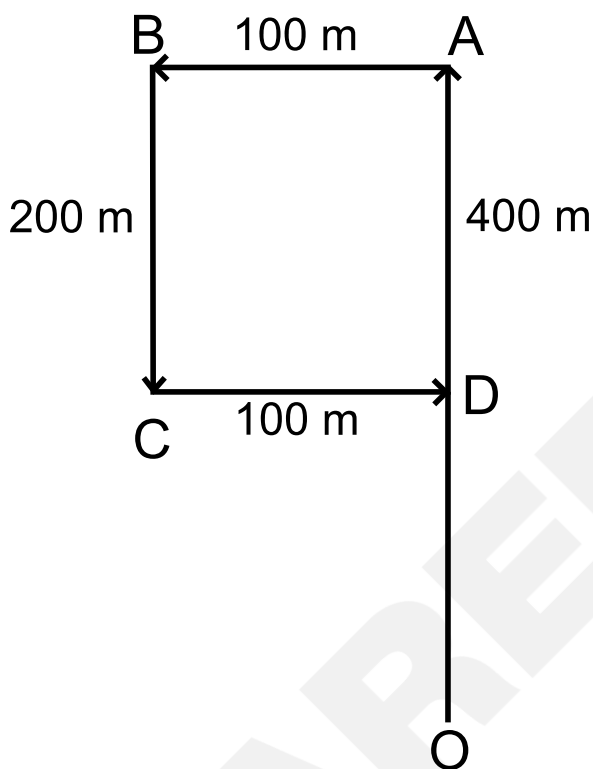

In the above figure, O is the starting point and D is the finishing point.

So, OD is the distance from the starting point.

$$OD = OA - AD \quad (AD = BC = 200)$$

$$OD = 400 - 200$$

$$OD = 200 \text{ metres}$$

So, Prem is 200 metres away from his house. Hence, the **third option** is correct.

**Q. 81** **Directions:** Prabhu travelled from his house a distance of 20 km to his friend's house. After some time, he left his friend's house took a turn towards the right and travelled 15 km to reach a park. After resting for a while, he again started to turn to the right and travelled 18 km to reach a petrol pump. From there he again turned right and covered a distance of 15 km. How many km more does he have to travel to reach home?

**Option 1:**

2 km

**Option 2:**

18 km

**Option 3:**

21 km

**Option 4:**

23 km

**Correct Answer:**

2 km

**Solution:**

Firstly, we will draw the diagram as per the given instructions –

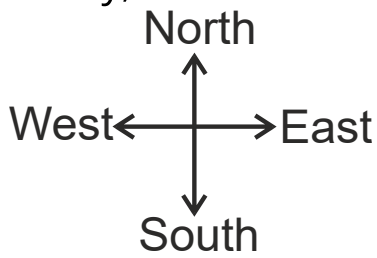

Let Prabhu travel from his house in the north direction. Now, draw the diagram as per the given instructions –

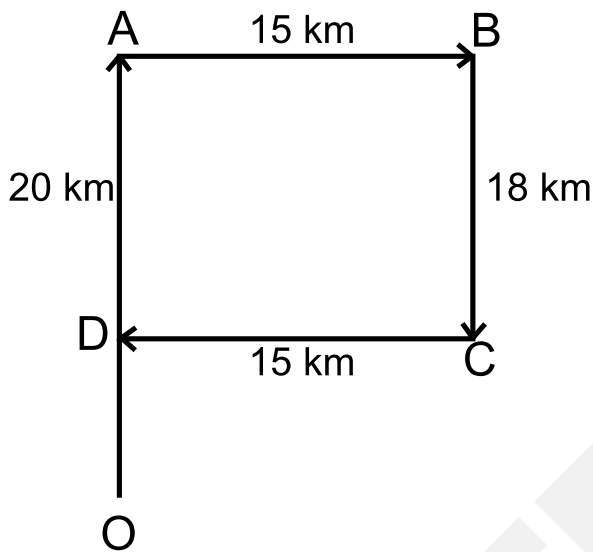

In the above figure, O is the starting point and D is the finishing point.

So, OD is the distance from the starting point.

$$OD = OA - AD \quad (AD = BC = 18 \text{ km})$$

$$OD = 20 - 18$$

$$OD = 2 \text{ km}$$

So, the distance from the starting point is 2 km. Hence, the **first option** is correct.

**Q. 82** **Directions:** Rohan walks a distance of 3 km towards the north, then turns to his left and walks for 2 km. He again turns left and walks for 3 km. At this point, he turns to his left and walks for 3 km. How far is he from the starting point?

**Option 1:**

5 km

**Option 2:**

3 km

**Option 3:**

2 km

**Option 4:**

1 km

**Correct Answer:**

1 km

**Solution:**

Firstly, we will draw the diagram as per the given instructions –

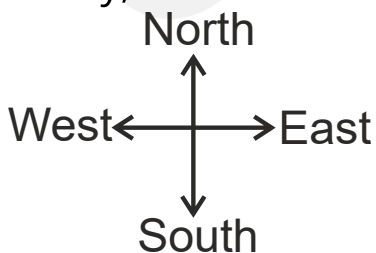

Now, we have to find the distance between starting and endpoints.

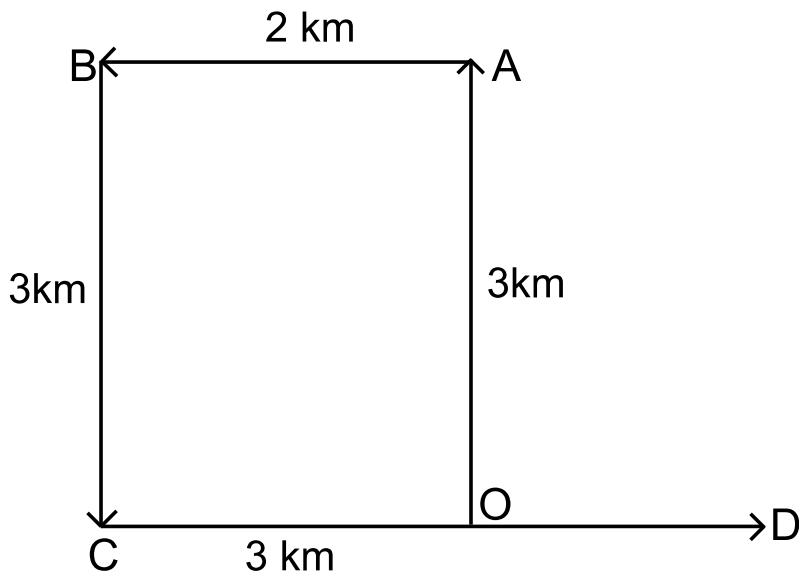

In the above figure, O is the starting point and D is the finishing point. So, OD is the distance from the starting point.

$$OD = CD - OC \quad (OC = AB = 2)$$

$$OD = 3 - 2$$

$$OD = 1 \text{ km}$$

So, the distance from the starting point is 1 km. Hence, the **fourth option** is correct.

- Q. 83** **Directions:** I go 5 km east, then turn right and go 8 km. Then I turn left and go 5 km, and then I turn left and go 8 km. At what distance am I from the starting point?

**Option 1:**

8 km

**Option 2:**

0 km

**Option 3:**

10 km

**Option 4:**

5 km

**Correct Answer:**

10 km

**Solution:**

Firstly, we will draw the diagram as per the given instructions –

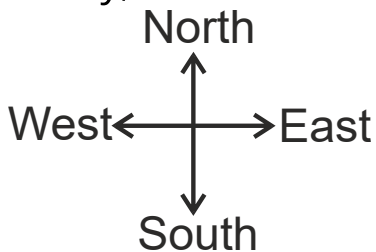

Now, we have to find the distance between the starting point and the endpoint.

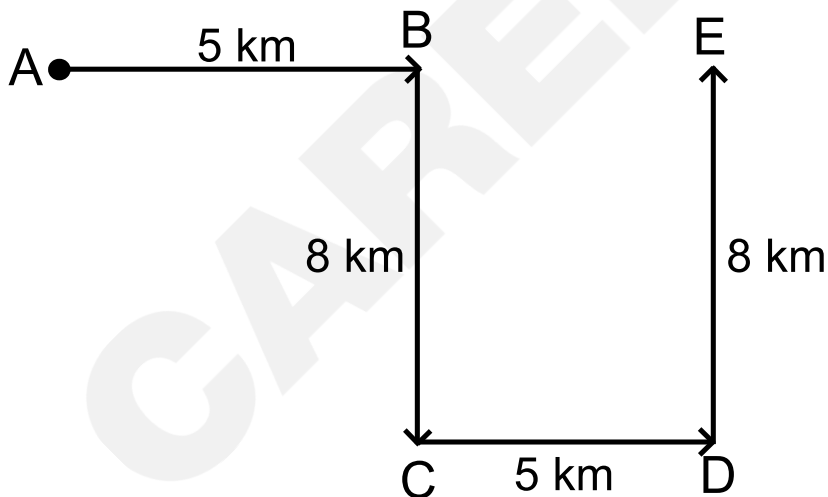

In the figure, A is the starting point and E is the endpoint. So, AE is the distance between the starting point and the endpoint.

$$AE = AB + BE$$

Here,  $AB = 5$  km and  $BE = CD = 5$  km

Therefore,  $AE = 5 + 5 = 10$  km

So, the distance between the starting point and the endpoint is 10 km. Hence, the **third option** is correct.

**Q. 84** **Directions:** Rana walks 20 m straight in the north direction and 20 m to the right. Then every time turning to his left, he walks 5 m, 25 m, and 25 m respectively. How far is he from his starting point now?

**Option 1:**

5 m

**Option 2:**

20 m

**Option 3:**

25 m

**Option 4:**

30 m

**Correct Answer:**

5 m

**Solution:**

Firstly, we will draw the diagram as per the given instructions –

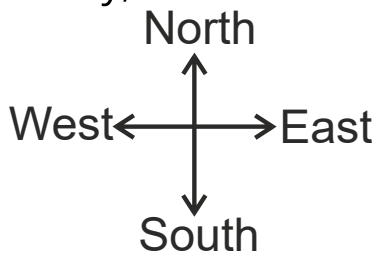

Now, we have to find the distance between the starting point and the endpoint.

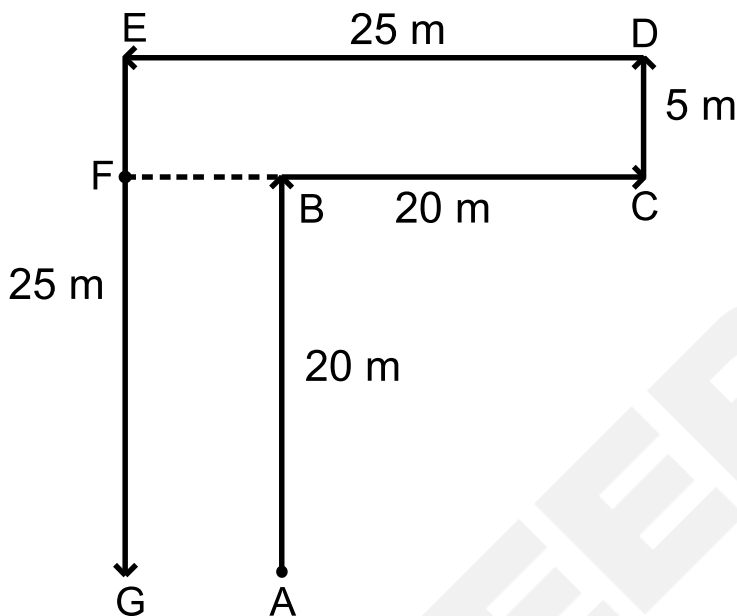

In the figure, A is the starting point and G is the endpoint. So, AG is the distance between the starting point and the endpoint.

Here,  $CD = EF = 5 \text{ m}$ ,  $CB = 20 \text{ m}$ ,  $DE = CF = 25 \text{ m}$

$$BF = CF - CB$$

$$BF = 25 - 20$$

$$BF = 5 \text{ m}$$

$$\text{And, } BF = AG = 5 \text{ m}$$

So, the distance between the starting point and the endpoint is 5 m. Hence, the **first option** is correct.

**Q. 85** **Directions:** Deepu started his journey from A and moved 2 km towards the South, then he turned right and moved 0.5 km. Again, he takes a right turn and walks 2 km. Now he takes a left turn and walks 3 km more. How far he is from the starting point?

**Option 1:**  
3.5 km

**Option 2:**  
2.5 km

**Option 3:**  
7.5 km

**Option 4:**  
1.5 km

**Correct Answer:**  
3.5 km

**Solution:**

Firstly, we will draw the diagram as per the given instructions –

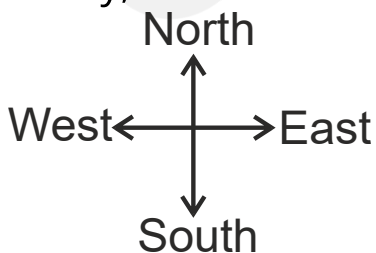

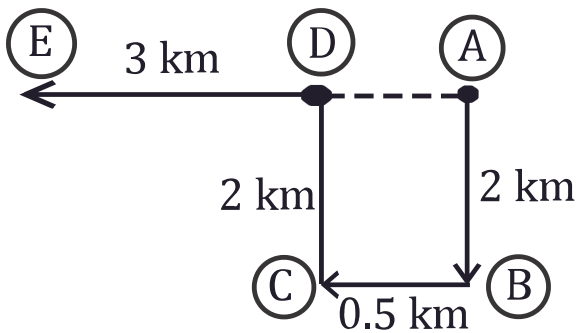

In the figure, A is the starting point and E is the finishing point. So, AE is the distance from the starting point.

Here,  $BC = AD = 0.5$  km,  $AB = CD = 2$  km and  $DE = 3$  km

Now,  $AE = AD + DE$

$AE = 0.5 + 3 = 3.5$  km

So, the distance from the starting point is 3.5 km. Hence, the **first option** is correct.

- Q. 86** **Directions:** Ajit, starting from a fixed point, goes 10 m towards the north, and then after turning to his right, he goes 10 m. then he goes 5, 10, and 10 metres after turning to his left each time. How far is he from his starting point?

**Option 1:**

15 m

**Option 2:**

10 m

**Option 3:**

5 m

**Option 4:**

3 m

**Correct Answer:**

5 m

**Solution:**

Firstly, we will draw the diagram as per the given instructions –

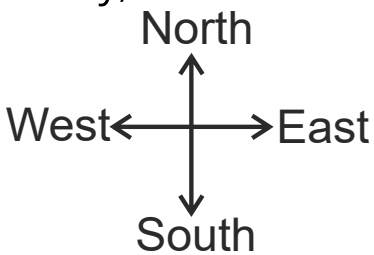

Now, we have to find the distance between the starting point and the endpoint.

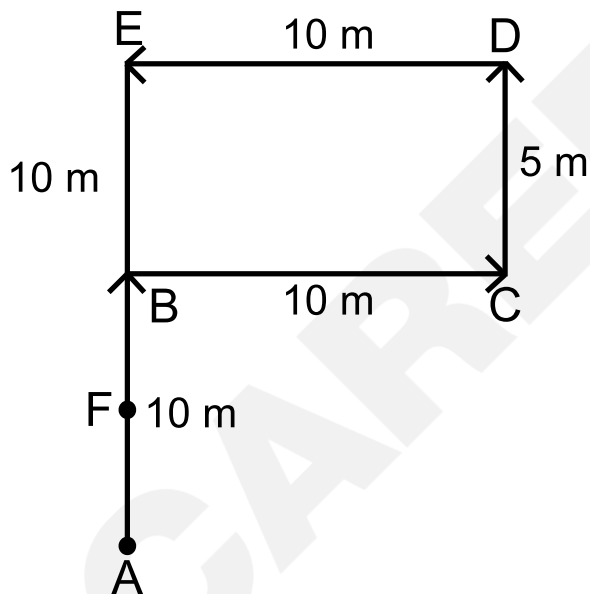

In the figure, A is the starting point and F is the finishing point. So, AF is the distance from the starting point.

Here,  $AB = 10\text{ m}$ ,  $BE = CD = 5\text{ m}$ ,  $EF = 10\text{ m}$

Now,  $AF = AB + BE - EF$

$$AF = 10 + 5 - 10$$

$$AF = 5\text{ m}$$

So, the distance from the starting point is 5 m. Hence, the **third option** is correct.

**Q. 87** **Directions:** Dinesh travels from point A, 8 km eastward towards B, turns right and walks 12 km to C, turns again right and walks 4 km to point D, again turns right and travels 8 km to E. From E, he turns left and walks to F, 4 km. Now how far is he from his starting point?

**Option 1:**

4 km

**Option 2:**

6 km

**Option 3:**

8 km

**Option 4:**

12 km

**Correct Answer:**

4 km

**Solution:**

Firstly, we will draw the diagram as per the given instructions –

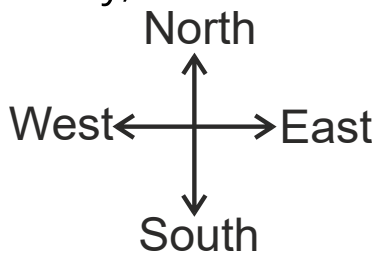

Now, we have to find the distance between the starting point and the endpoint.

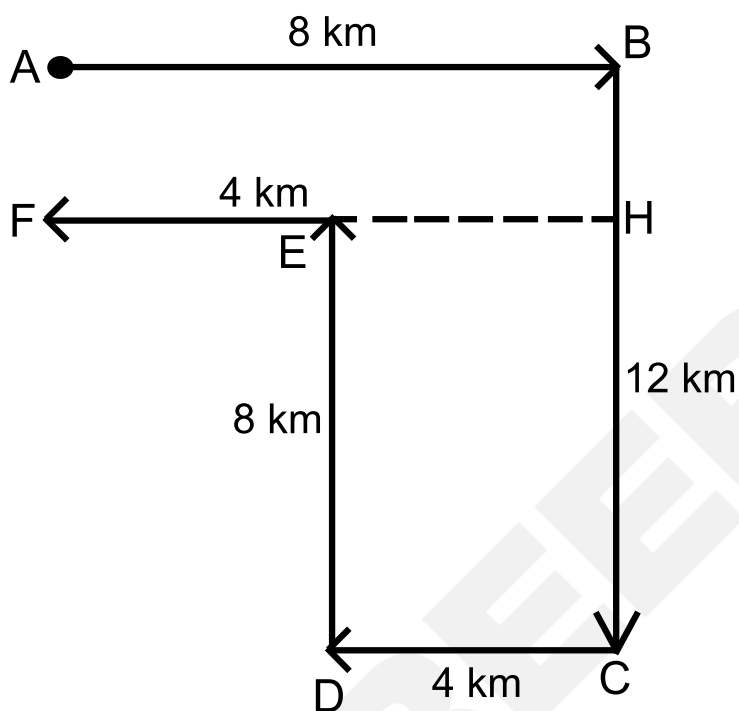

In the given figure, A is the starting point and F is the finishing point.

So, AF is the distance from the starting point.

Here,  $CD = HE = 4 \text{ km}$ ,  $DE = CH = 8 \text{ km}$

Now,  $BH = BC - CH$

$BH = 12 - 8 = 4 \text{ km}$

And,  $AF = BH = 4 \text{ km}$

So, the distance from the starting point is 4 km. Hence, the **first option** is correct.

**Q. 88** **Directions:** Sunita travels 6 km towards the northeast. Then travels 9 km towards the west. From there, she goes 6 km southwest and finally goes 3 km east. How far is she from her initial position?

**Option 1:**

3 km

**Option 2:**

6 km

**Option 3:**

9 km

**Option 4:**

12 km

**Correct Answer:**

6 km

**Solution:**

Firstly, we will draw the diagram as per the given instructions –

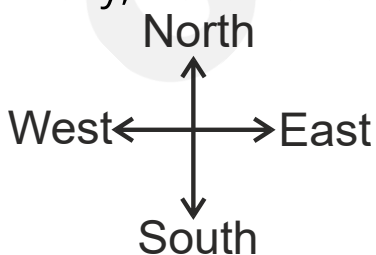

Now, we have to find the distance between starting and endpoints.

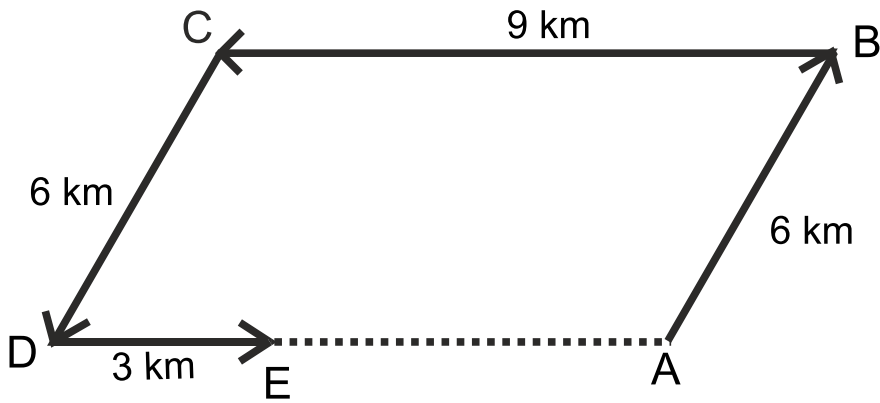

In the given figure, A is the starting point and E is the finishing point. So, AE is the distance from the starting point.

Here,  $DE = 3$  km,  $AB = CD = 6$  km and  $AD = BC = 9$  km

Now,  $AE = AD - DE$

$$AE = 9 - 3$$

$$AE = 6 \text{ km}$$

So, the distance from the starting point to the endpoint is 6 km. Hence, the **second option** is correct.

- Q. 89** **Directions:** Kishore starts from a point and walks 6 km towards the east and turning to his left he moves 3 km after this, he again turns to his left and moves 6 km. Now how far is he from his starting point?

**Option 1:**

3 km

**Option 2:**

2 km

**Option 3:**

4 km

**Option 4:**

5 km

**Correct Answer:**

3 km

**Solution:**

Firstly, we will draw the diagram as per the given instructions –

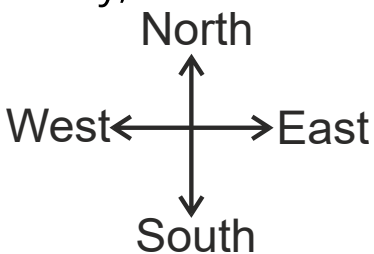

Now, we have to find the distance between starting and endpoints.

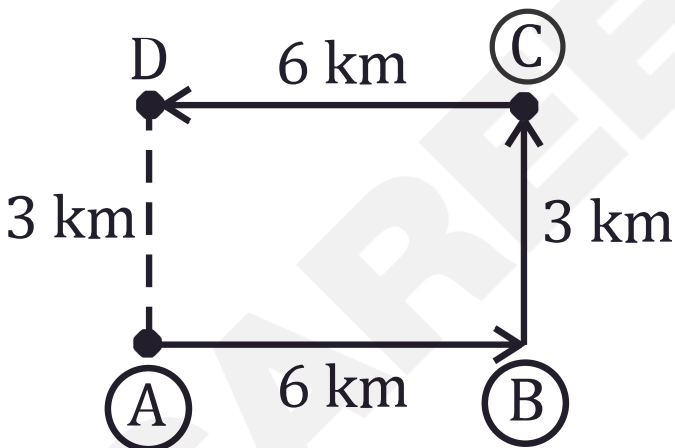

In the figure, A is the starting point and D is the finishing point. So, AD is the distance from the starting point.

Here,  $AB = CD = 6 \text{ km}$

And,  $AD = BC = 3 \text{ km}$

So, the distance from the starting point is 3 km. Hence, the **first option** is correct.

**Q. 90** **Directions:** A hiker walks 2 km south, then turns west and walks for 4 km, then turns north and walks for 5 km, then turns to his right and walks for 4 km. Where is he now from his starting position?

**Option 1:**

7 km, North

**Option 2:**

3 km, North

**Option 3:**

3 km, South

**Option 4:**

7 km, South

**Correct Answer:**

3 km, North

**Solution:**

Firstly, we will draw the diagram as per the given instructions –

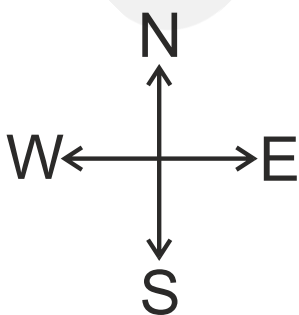

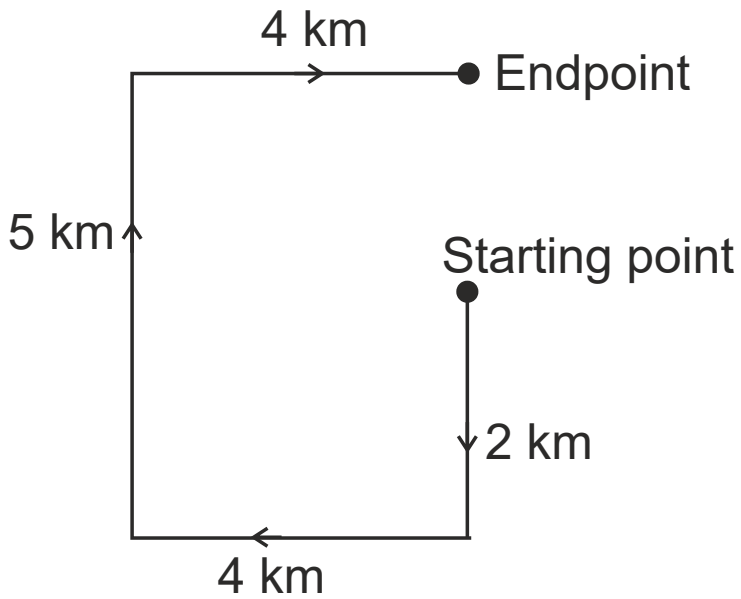

So, from the above, the distance between the starting point and the endpoint is 3 km, and the hiker is now in the North direction from his starting position.

Hence, the **second option** is correct.

- Q. 91** **Directions:** Two village women are returning home starting from the same point. The first woman walks 1 km South, then turns to her right and walks 6 km to reach her house. In the meantime, the second woman walks 5 km west, then turns north and walks 4 km, then turns to her left and walks 1 km to reach her house. Where is the second woman's house from the first woman's house?

**Option 1:**  
5 km, North

**Option 2:**

3 km, North

**Option 3:**

5 km, South

**Option 4:**

3 km, South

**Correct Answer:**

5 km, North

**Solution:**

Firstly, we will draw the diagram as per the given instructions –

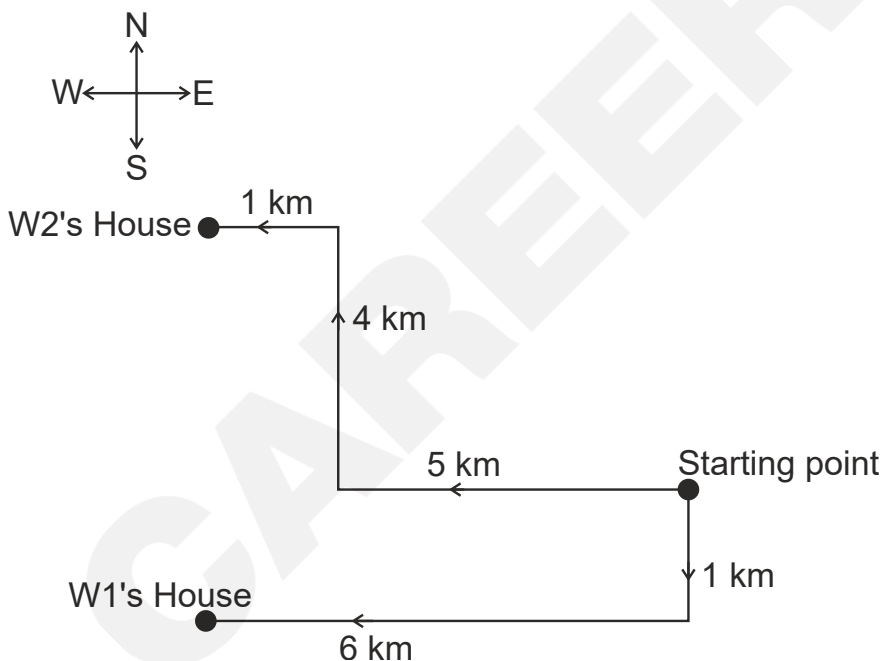

Now, find the distance between the second woman's house and the first woman's house –

The distance between the second woman's house and the first

woman's house =  $1 + 4 = 5$  km

And the direction of the second woman's house from the first woman's house is North.

So, the distance between the second woman's house and the first woman's house is 5 km, North. Hence, the **first option** is correct.

**Q. 92**     **Directions:** A man drives his car 6 km towards West, then turns left and drives 3 km and again turns left and drives 3 km. Find out the final direction of the man from his original position.

**Option 1:**  
South-West

**Option 2:**  
North-West

**Option 3:**  
North-East

**Option 4:**  
South-East

**Correct Answer:**  
South-West

**Solution:**

Firstly, we will draw the diagram as per the given instructions –

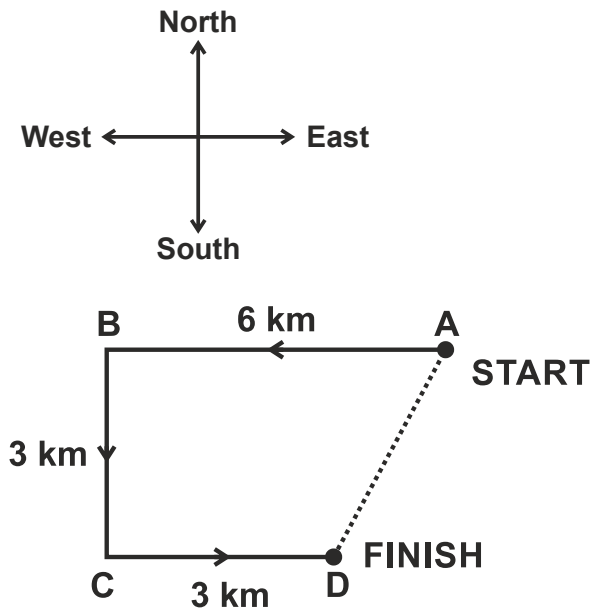

The direction from the starting point (A) to the finishing point (D) is southwest.

So, the final direction of the man from his original position is southwest. Hence, the **first option** is correct.

- Q. 93** **Directions:** A tourist drives 10 km towards the West turns to the left and takes a drive of another 4 km. He then drives towards the East another 4 km and then turns to his right and drives 5 km. Afterwards, he turns to his left and travels 6 km. In which direction is he from the starting point?

**Option 1:**  
North

**Option 2:**

East

**Option 3:**

West

**Option 4:**

South

**Correct Answer:**

South

**Solution:**

Firstly, we will draw the diagram as per the given instructions –

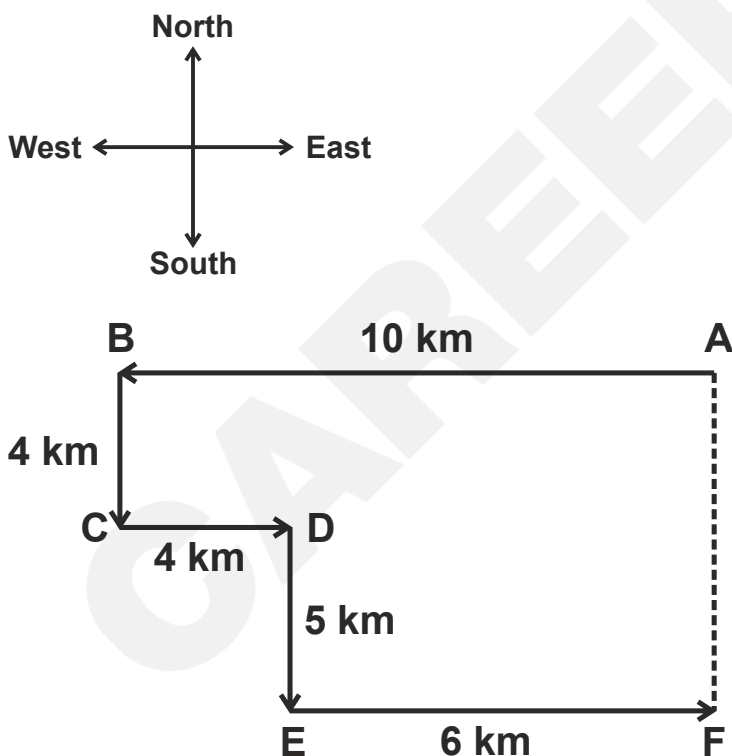

The direction from the starting position (A) to the final position (F) is south.

So, the tourist is in the south direction. Hence, the **fourth option** is correct.

**Q. 94** **Directions:** Ramdev goes 40 m to the south of his house, then turns left and goes another 10 m. Then turning to the North, he goes 20 m and then starts walking to his house. In which direction is he walking now?

**Option 1:**  
North-West

**Option 2:**  
North-East

**Option 3:**  
South-East

**Option 4:**  
South-West

**Correct Answer:**  
North-West

**Solution:**

Firstly, we will draw the diagram as per the given instructions –

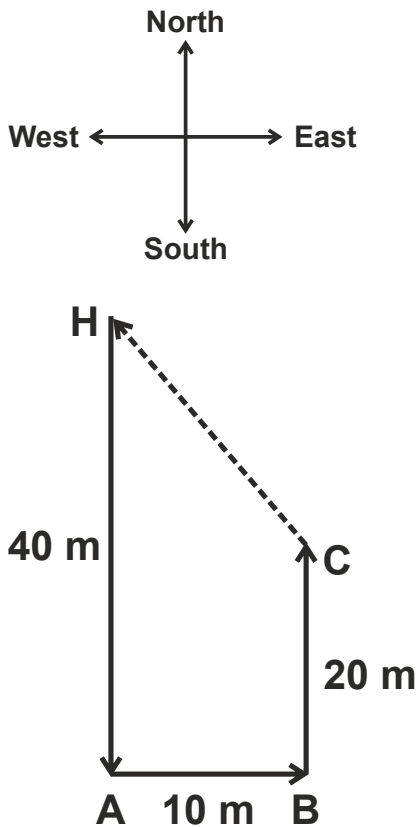

The direction from his final position (C) to his house (H) is north-west.

So, Ramdev is walking in the north-west direction. Hence, the **first option** is correct.

- Q. 95** **Directions:** Ramesh walks 2 km to the west then turns to his right walks 3 km then again turns right walks 2 km and finally turns to his right. Which direction is he facing?

**Option 1:**

East

**Option 2:**

West

**Option 3:**

North

**Option 4:**

South

**Correct Answer:**

South

**Solution:**

Firstly, we will draw the diagram as per the given instructions –

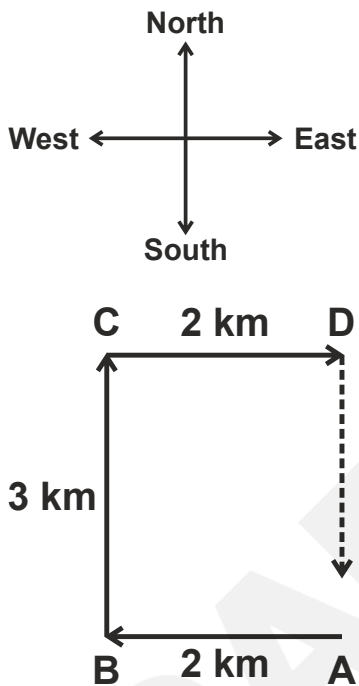

The direction from point D towards A is the south direction.

So, Ramesh is facing in the south direction. Hence, the **fourth option** is correct.

**Q. 96** **Directions:** Raghu jogged 2 km southwards, then he turned right and walked 5 km. He again turned right and walked and jogged 8 km. In which direction was he seen moving last?

**Option 1:**

West

**Option 2:**

East

**Option 3:**

South

**Option 4:**

North

**Correct Answer:**

North

**Solution:**

Firstly, we will draw the diagram as per the given instructions –

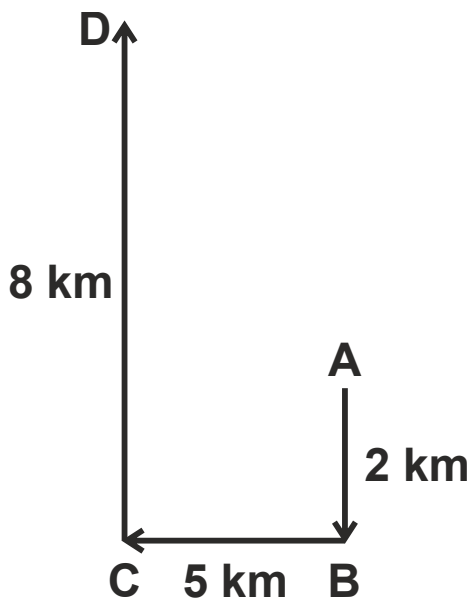
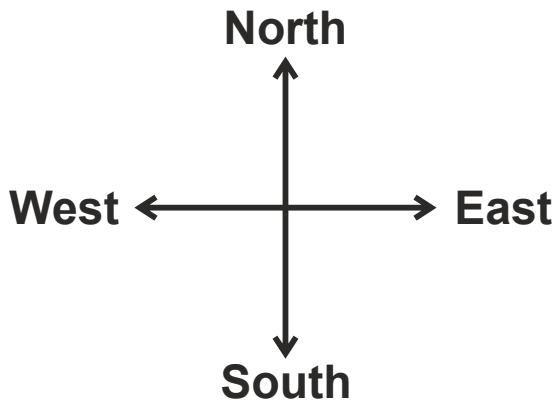

The final direction from point (C) to point (D) is the north direction.

So, Rahul was seen moving in the north direction. Hence, the **fourth option** is correct.

- Q. 97** **Directions:** Sitara walked 45 metres northwest of her uncle's house. There she met her friend and they walked 45 metres in the southwest direction. Then they walked 45 metres in the southeast direction and turned to their uncle's house. Now, in which direction they are going?

**Option 1:**  
Northwest

**Option 2:**  
Southwest

**Option 3:**  
Northeast

**Option 4:**  
Southeast

**Correct Answer:**  
Northeast

**Solution:**

Firstly, we will draw the diagram as per the given instructions –

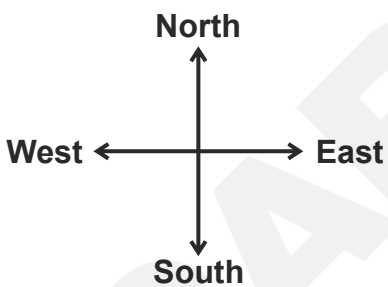

Now, we have to find the direction in which direction Sitara is moving.

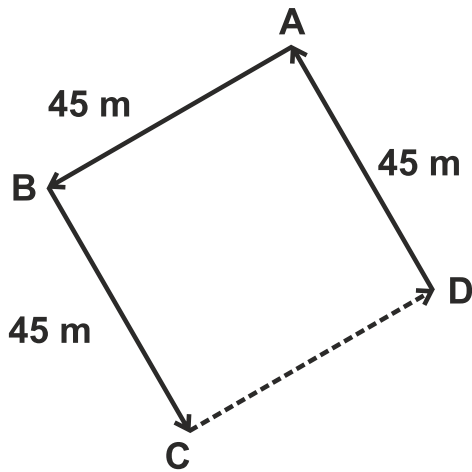

Here, D is the starting position (Uncle's house) and C is the final position. Therefore, the direction from his final point (C) to his uncle's house (D) is northeast.

So, now they are going in the northeast direction. Hence, the **third option** is correct.

**Q. 98** **Directions:** The mall is 250 metres Northwest of the market. The school is 250 metres southwest of the market. In which direction is the school from the mall?

**Option 1:**  
East

**Option 2:**  
West

**Option 3:**  
South

**Option 4:**

North

**Correct Answer:**

South

**Solution:**

Firstly, we will draw the diagram as per the given instructions –

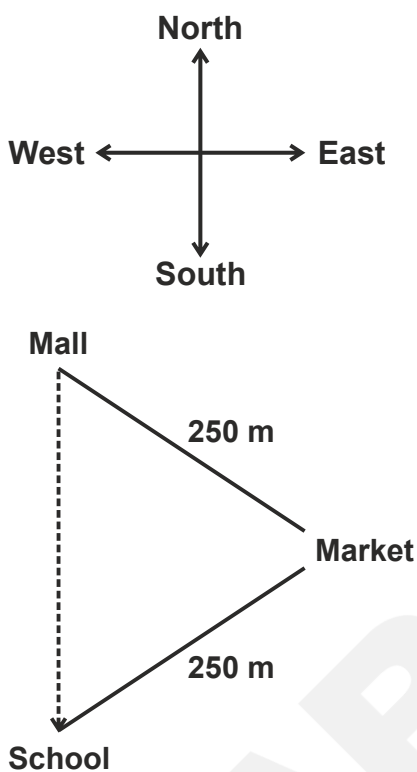

So, the school is in the south direction of the mall. Hence, the **third option** is correct.

**Q. 99** **Directions:** Raheja started from a point. He walked 3 km to the North, then turned East and walked 4 km, then turned West walked 2 km, and then turned left and walked 3 km, and stopped. In which direction is Raheja from his starting point?

**Option 1:**  
East

**Option 2:**  
South

**Option 3:**  
North

**Option 4:**  
West

**Correct Answer:**  
East

**Solution:**

Firstly, we will draw the diagram as per the given instructions –

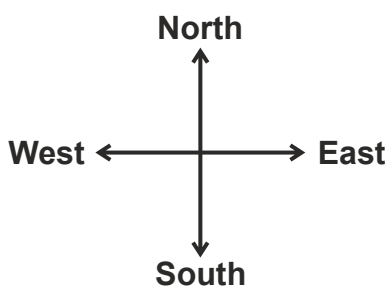

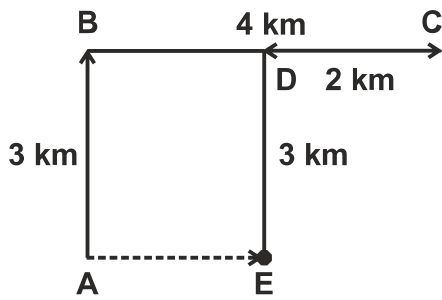

The direction from his starting position (A) to his final position (E) is the east direction.

So, Raheja is in the east direction from his starting point. Hence, the **first option** is correct.

**Q.**  
**100**

**Directions:** After walking 200 metres, I turned right and covered a distance of 100 metres, then turned left and covered a distance of 300 metres. In the end, I am facing north. From which direction did I start my journey?

**Option 1:**  
West

**Option 2:**  
East

**Option 3:**  
North

**Option 4:**  
South

**Correct Answer:**

North

**Solution:**

Firstly, we will draw the diagram as per the given instructions -

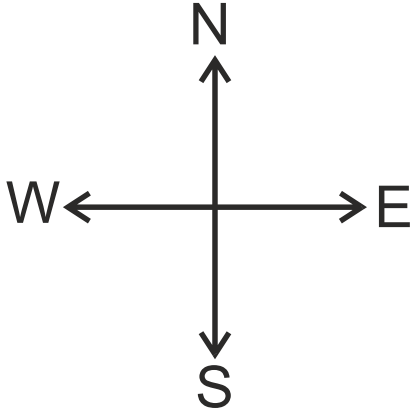

Let A be the starting point and D be the endpoint.

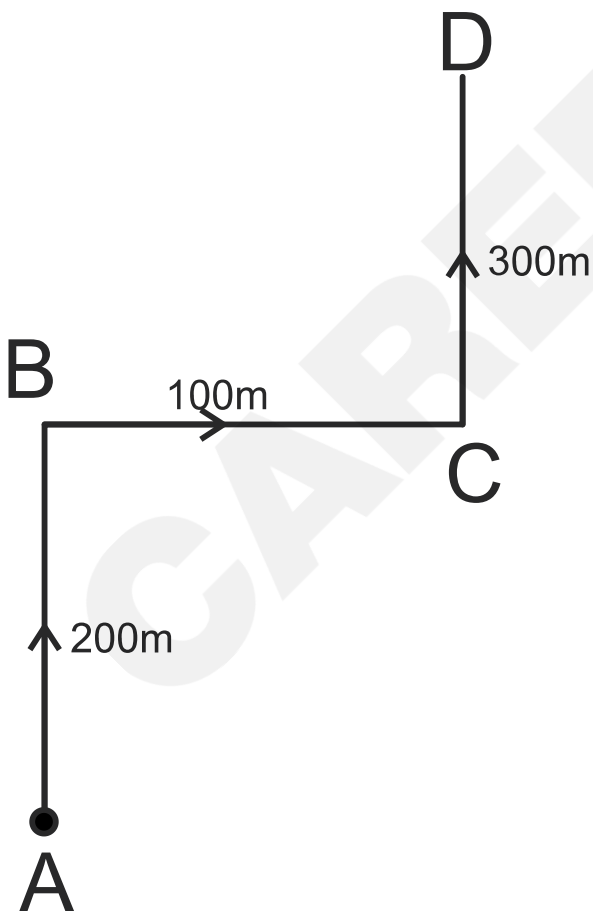

In the end, I am facing north. So, I started my journey facing the north direction. Hence, the **third option** is correct.

**Q.  
101**

**Directions:** Of the 5 towns A, B, C, D, and E are situated close to each other. A is to the west of B, C is to the south of A, E is to the north of B and D is to the east of E. Then C is in which direction with respect to D?

**Option 1:**  
Southwest

**Option 2:**  
Northeast

**Option 3:**  
Northwest

**Option 4:**  
Southeast

**Correct Answer:**  
Southwest

**Solution:**

Firstly, we will draw the diagram as per the given instructions –

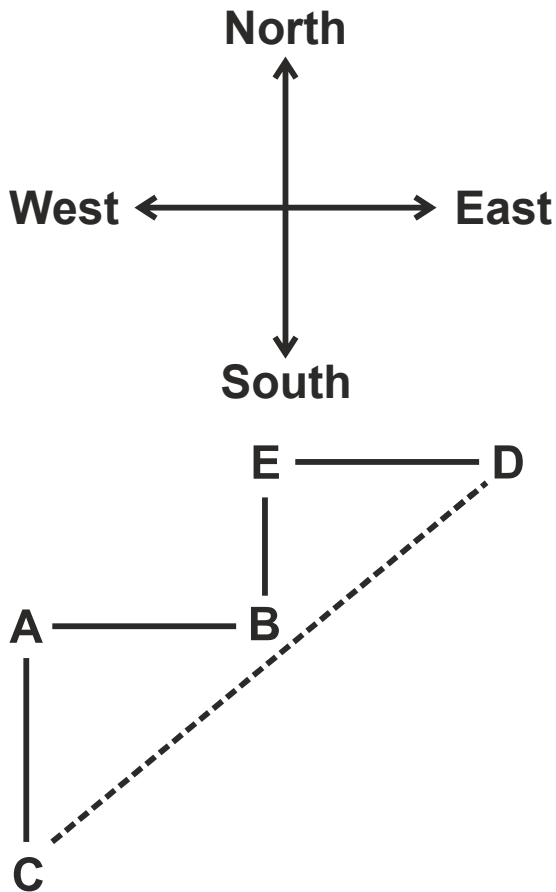

The direction point C with respect to D is in the southwest direction.

So, C is in the southwest direction with respect to D. Hence, the **first option** is correct.

**Q.**  
**102**

**Directions:** Suresh walked 7 km East turned to his left and walked 4 km. He then turned to his right and walked 5 km. Finally, he again turned to his right and walked 4 km. In which direction is he now, from his starting point?

**Option 1:**  
South

**Option 2:**

West

**Option 3:**

East

**Option 4:**

North

**Correct Answer:**

East

**Solution:**

Firstly, we will draw the diagram as per the given instructions –

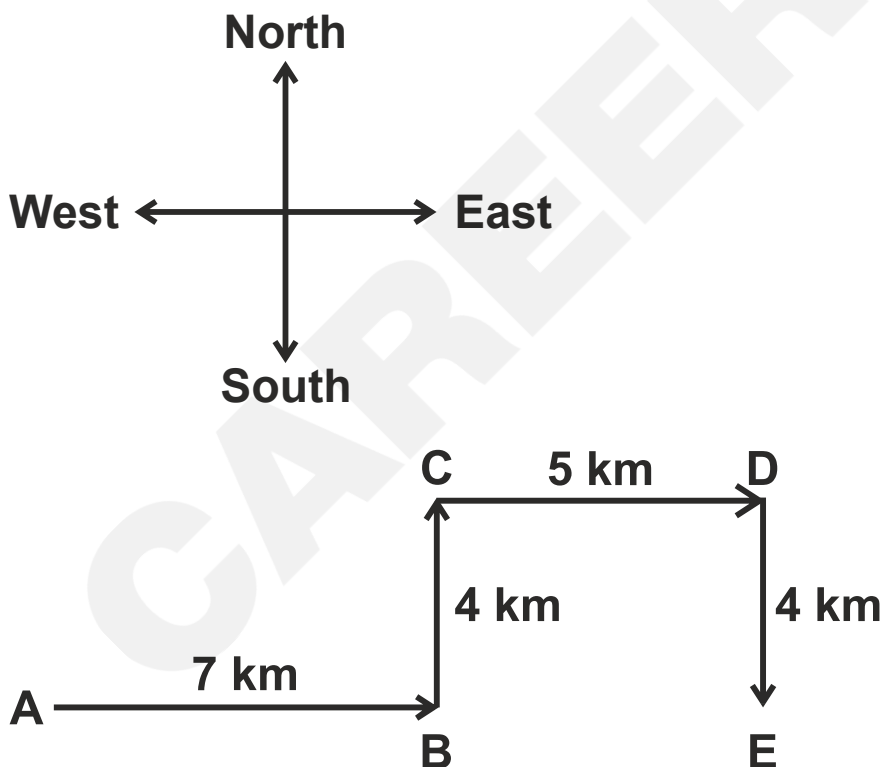

The starting point of Suresh is A and the endpoint is E.

So, Suresh is in the east direction from his starting point. Hence, the **third option** is correct.

**Q.  
103**

**Directions:** Ram walks 2 km to the east, then he turns to the South and walks 6 km. He again turns to the East and walks 2 km, then he turns to the North and walks 12 km. How far is he from the starting point?

**Option 1:**

7 km

**Option 2:**

7.1 km

**Option 3:**

7.2 km

**Option 4:**

7.3 km

**Correct Answer:**

7.2 km

**Solution:**

According to the instructions given, the diagram is as follows –

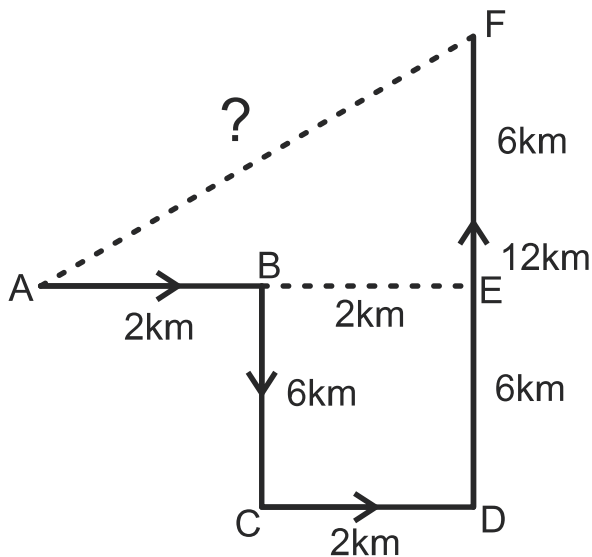

Here, A is the starting point and F is the finishing point and AF is the total distance from the starting point.

AB = 2 km; BC = 6 km; CD = BE = 2 km; DF = 12 km; DE = EF = 6 km  
And, AE = AB + BE = 2 + 2 = 4 km

By applying the Pythagoras theorem -

$$(AF)^2 = (AE)^2 + (EF)^2$$

$$(AF)^2 = (4)^2 + (6)^2 = 16 + 36 = 52$$

$$\Rightarrow AF = \sqrt{52} = 7.2 \text{ km}$$

So, the total distance from the starting point is 7.2 km. Hence, the **third option** is correct.

**Q.**  
**104**

**Directions:** Ram walks 12 km to the north, then 10 km to the West, and 12 km to the South. How far is Ram from the starting point?

**Option 1:**

9 km

**Option 2:**

13 km

**Option 3:**

8 km

**Option 4:**

10 km

**Correct Answer:**

10 km

**Solution:**

Firstly, we will draw the diagram as per the given instructions –

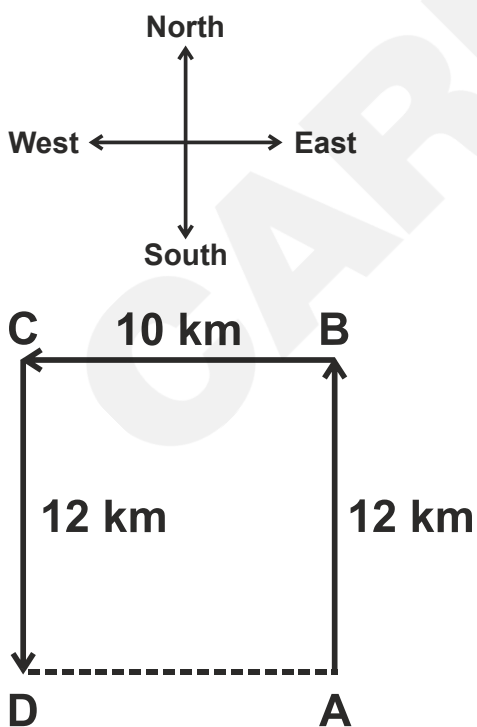

The distance between point A and the endpoint D = 10 km

So, Ram is 10 km far from the starting point. Hence, the **fourth option** is correct.

**Q.  
105**

**Directions:** A cyclist rides 40 km to the east, turns north, and rides 20 km, again turns left and rides 20 km. How far (approx) is he from the starting point?

**Option 1:**

0 km

**Option 2:**

10 km

**Option 3:**

20 km

**Option 4:**

30 km

**Correct Answer:**

30 km

**Solution:**

According to the instructions given, the diagram is as follows –

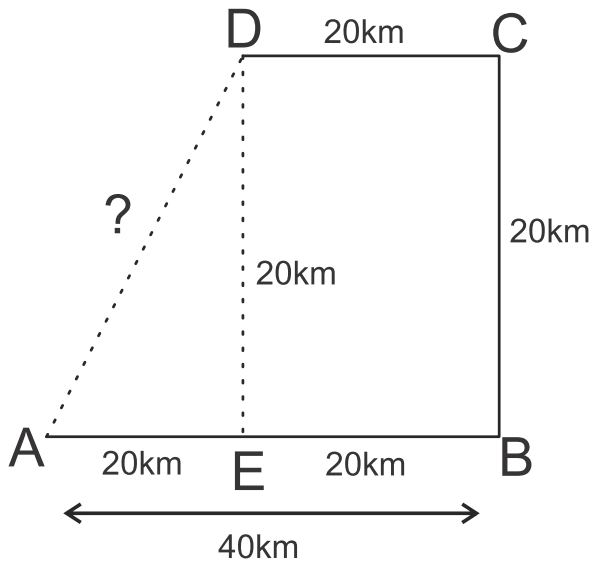

Here, A is the starting point, D is the finishing point and AD is the distance from the starting point.

$AB = 40 \text{ km}$ ;  $BC = 20 \text{ km}$  and  $CD = 20 \text{ km}$

$AE = 20 \text{ km}$  and  $DE = 20 \text{ km}$

By applying the Pythagoras theorem -

$$(AD)^2 = (AE)^2 + (DE)^2$$

$$(AD)^2 = (20)^2 + (20)^2 = 400 + 400 = 800$$

$$\Rightarrow AD = \sqrt{800} = 28.28 = 30 \text{ km (Approx)}$$

So, the cyclist's distance from the starting point is 30 km. Hence, the **fourth option** is correct.

**Q.  
106**

**Directions:** Raju was to go to the planetarium. So, he walked 1.5 km towards the East from the place and then turned to the right and walked 2.5 km and then turned towards the East and walked 1 km and turned to the South and walked 4 km and reached the place by walking 2.5 km towards the West. What distance is he from the starting point?

**Option 1:**

6.5 km

**Option 2:**

9.5 km

**Option 3:**

10 km

**Option 4:**

9 km

**Correct Answer:**

6.5 km

**Solution:**

Firstly, we will draw the diagram as per the given instructions –

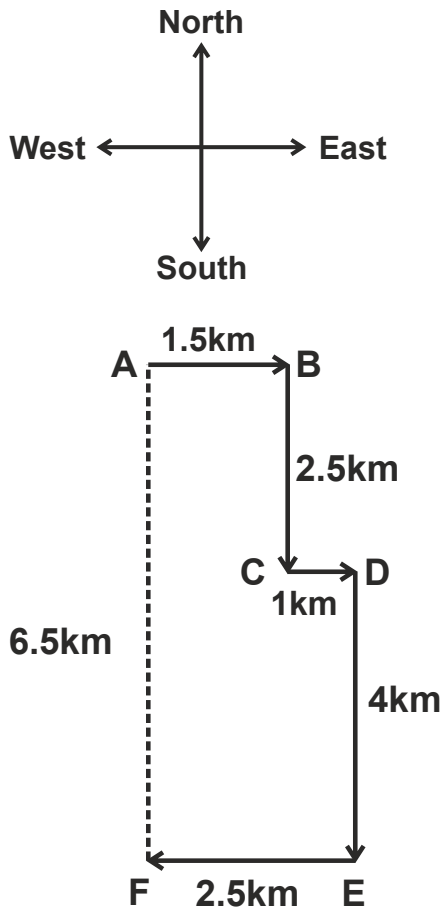

The distance between the initial point (A) and the final point (F) =  $2.5 + 4 = 6.5$  km

So, Raju is 6.5 km away from the starting point. Hence, the **first option** is correct.

**Q.**  
**107**

**Directions:** Mr Das started his journey from his house straight to his friend's house at a distance of 12 km. On returning he walked 8 km on the same route and turned right and walked 4 km, then he turned to his left and walked 4 km. Finally, he turned to his left and walked 2 km. How far was he from his house?

**Option 1:**

8 km

**Option 2:**

4 km

**Option 3:**

6 km

**Option 4:**

2 km

**Correct Answer:**

2 km

**Solution:**

Firstly, we will draw the diagram as per the given instructions –

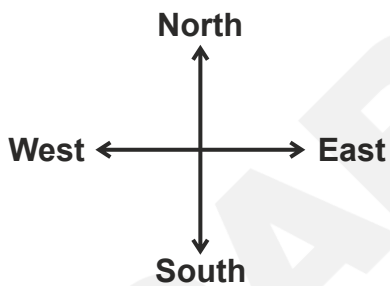

Assume that Mr Das starts his journey in the east direction.

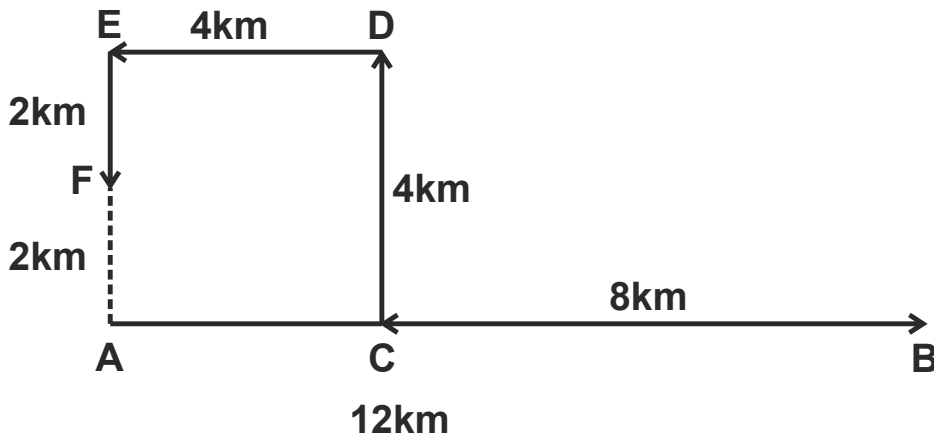

The distance between the initial point (A) and the endpoint (F) = 2 km

So, Mr Das is 2 km away from his house. Hence, the **fourth option** is correct.

**Q.  
108**

**Directions:** Seeta and Geeta started walking from point A. Seeta walks 6 km towards North and then takes a right turn and walks 3 km. She then takes a right turn and walks for 6 km. She again takes a left turn, walks 3 km, and reaches a point B. Geeta walks for 3 km towards the west, takes a left turn, and walks for 6 km. She then takes a left turn, walks 9 km, and reaches point C. How far is point B from point C?

**Option 1:**

3 km

**Option 2:**

4 km

**Option 3:**

9 km

**Option 4:**

6 km

**Correct Answer:**

6 km

**Solution:**

Firstly, we will draw the diagram as per the given instructions –

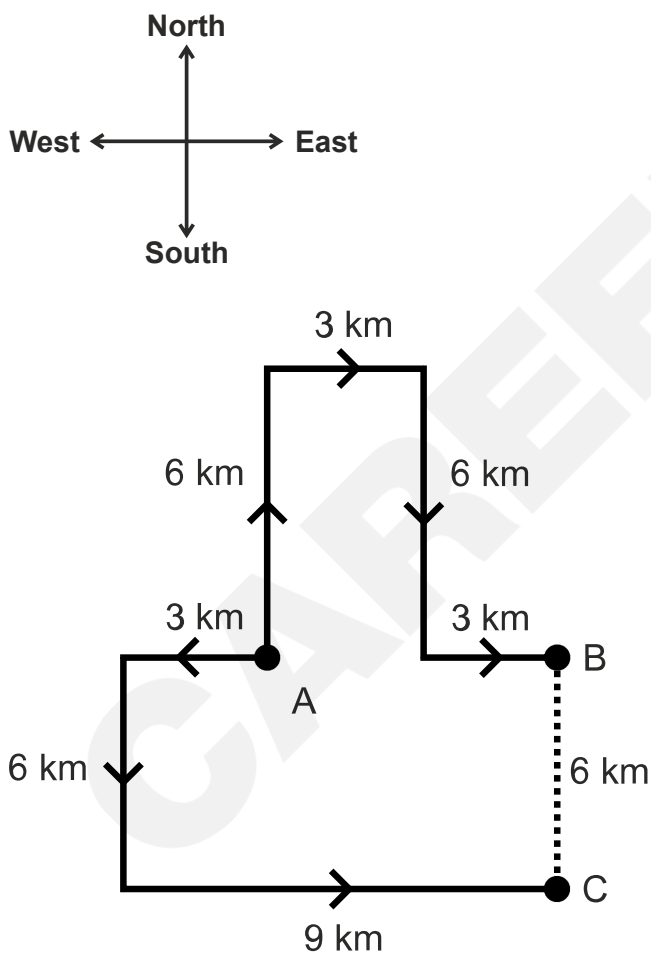

So, from the above, the distance between points B and C is 6 km.

Hence, the **fourth option** is correct.

**Q.  
109**

**Directions:** Ram and Shyam started from a fixed place. Ram moves 3 km to the north and turns right, then walks 4 km. Shyam moves towards the west and walks 5 km then turns to the right and walks 3 km. How far Ram is from Shyam?

**Option 1:**

13 km

**Option 2:**

16 km

**Option 3:**

9 km

**Option 4:**

10 km

**Correct Answer:**

9 km

**Solution:**

Firstly, we will draw the diagram as per the given instructions –

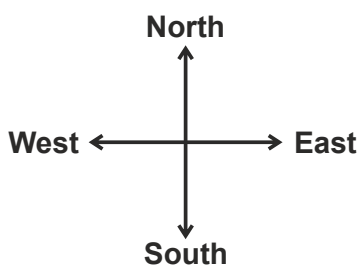

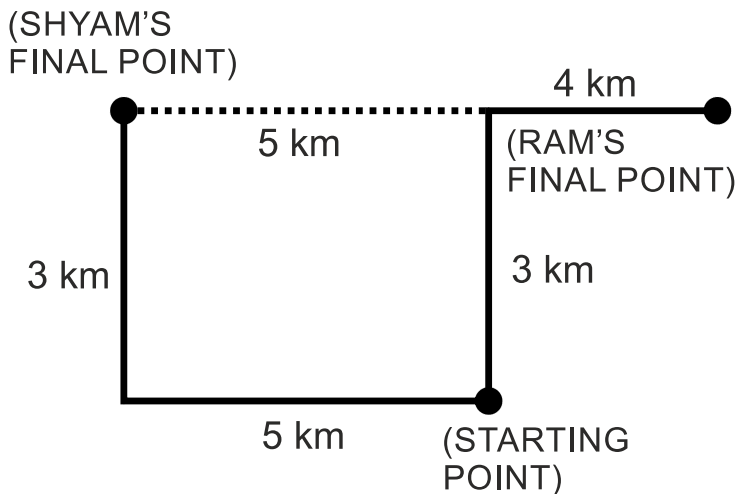

Distance between Shyam's final point and Ram's final point =  $5 + 4 = 9$  km

So, Ram is 9 km far from Shyam. Hence, the **third option** is correct.

**Q. 110**

**Directions:** A student walked out of the classroom towards the library. She went first to the canteen on the left side, 24 ft away after a cup of tea, took a right turn, and went to the laboratory 13 ft away. She then went to the physics block, 15 ft to the left. She talked to a friend, in the garden 3 ft on the left and continued walking in the same direction to the library, 10 ft more. What was the actual distance between the library and the classroom?

**Option 1:**

42 ft

**Option 2:**

65 ft

**Option 3:**

39 ft

**Option 4:**

34 ft

**Correct Answer:**

39 ft

**Solution:**

Firstly, we will draw the diagram as per the given instructions –

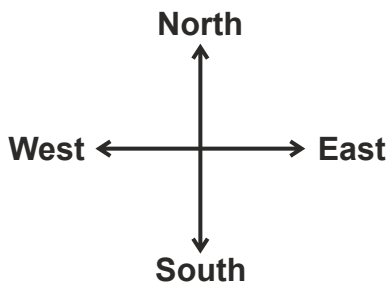

Assume that the student starts walking in the north direction from the classroom towards the canteen.

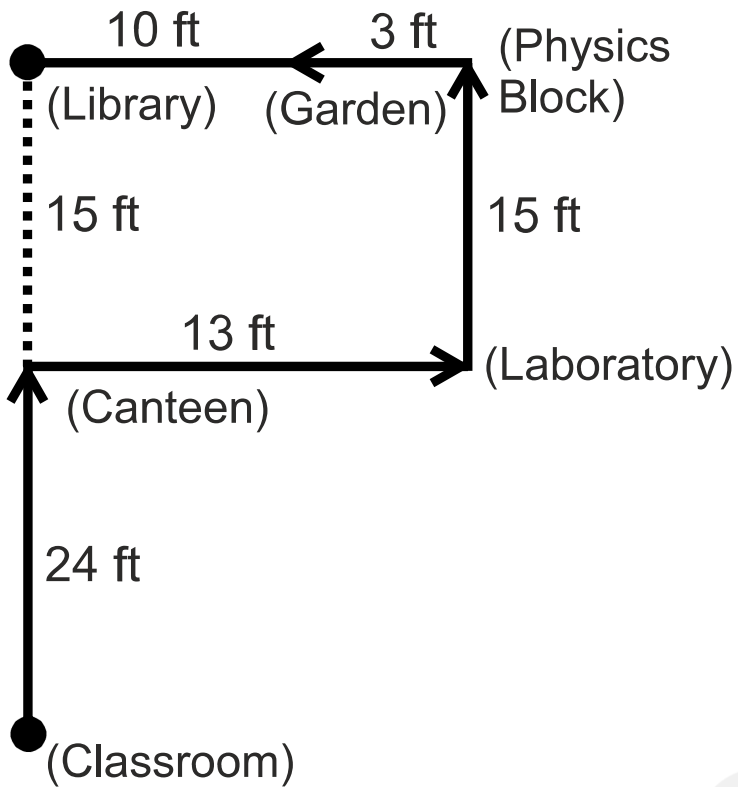

Distance between classroom and library =  $24 + 15 = 39$  ft

Hence, the **third option** is correct.

**Q.**  
**111**

**Directions:** Laxmi went 10 km to the west from my house, then turned left and walked 20 km. She then turned East, walked 25 km, and finally turned left covering 20 km. How far was she from my house?

**Option 1:**

5 km

**Option 2:**

10 km

**Option 3:**

15 km

**Option 4:**

40 km

**Correct Answer:**

15 km

**Solution:**

Firstly, we will draw the diagram as per the given instructions –

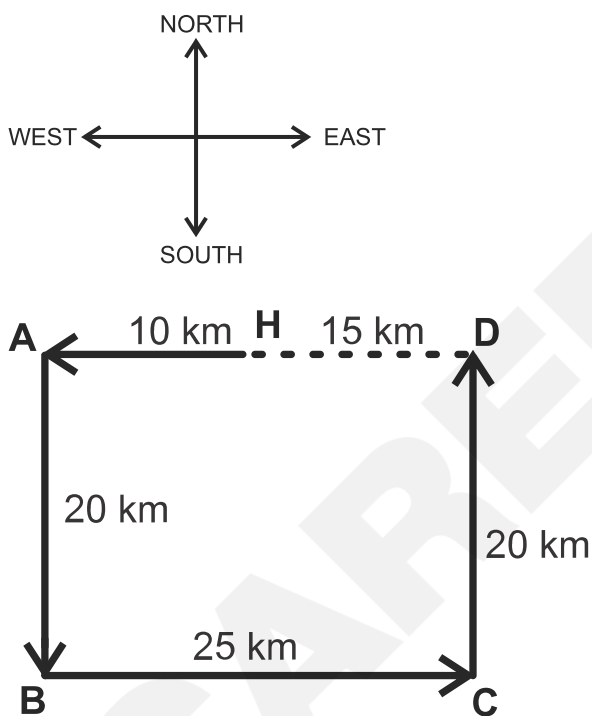

The distance between the house (H) and endpoint (D) = 15 km

So, Laxmi is 15 km away. Hence, the **third option** is correct.

**Q.  
112**

**Directions:** If Sita walks 10 km towards the west, then turns towards the South and walks 10 km, then turns East walks 10 km, and turns North walk 10 km. How far she is from the starting point?

**Option 1:**

40 km

**Option 2:**

0 km

**Option 3:**

10 km

**Option 4:**

20 km

**Correct Answer:**

0 km

**Solution:**

Firstly, we will draw the diagram as per the given instructions –

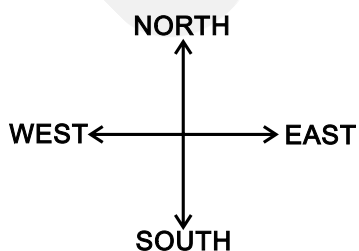

Now, we have to find the distance between the starting point and the endpoint.

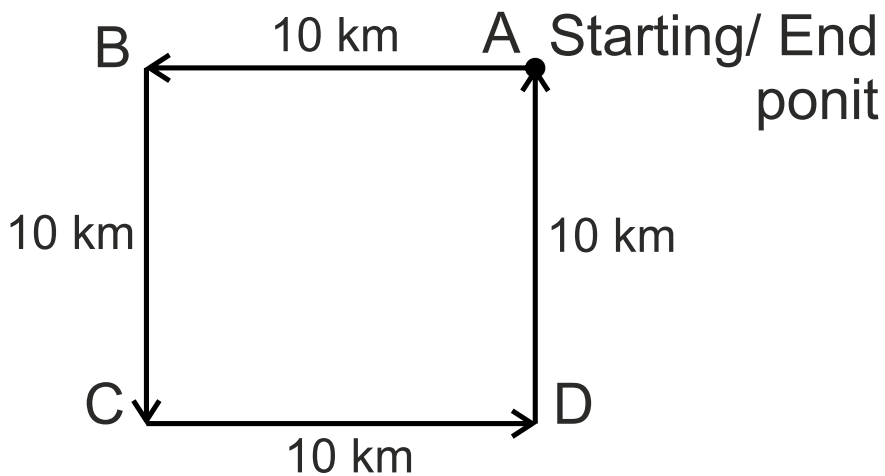

In the above figure, A is the starting point and the finishing point of Sita. So, the starting and the finishing points are the same i.e., the distance is 0 km. Hence, the **second option** is correct.

**Q.**  
**113**

**Directions:** Q walked 20 m towards the west, took a left turn, and walked 20 m. He then took a right turn and walked 20 m and again took a right turn and walked 20 m. How far is Q now from the starting point?

**Option 1:**

120 m

**Option 2:**

40 m

**Option 3:**

50 m

**Option 4:**

80 m

**Correct Answer:**

40 m

**Solution:**

Firstly, we will draw the diagram as per the given instructions –

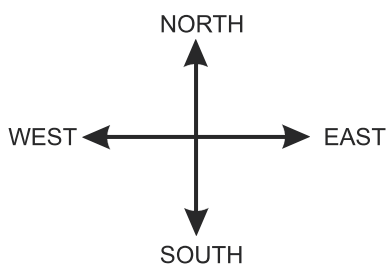

A is the starting point and E is the finishing point. So, we have to find the distance between AE.

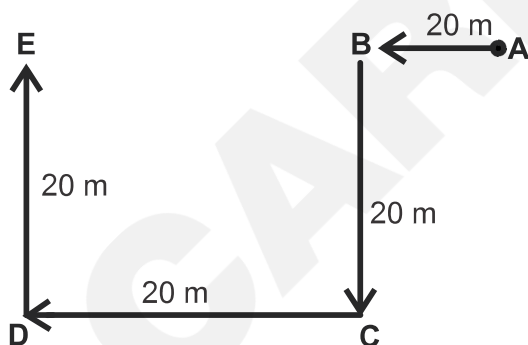

Here,  $AB = 20\text{ m}$ ,  $BC = DE = 20\text{ m}$ , and  $CD = BE = 20\text{ m}$

$$\Rightarrow AE = AB + BE = 20 + 20 = 40\text{ m}$$

So, the distance from the starting point is 40 m. Hence, the **second option** is correct.

**Q.  
114**

**Directions:** After going 80 m from his house towards the east, a person turns left and goes 20 m, then turns right and moves 100 m, then turns left and goes 60 m, then turns left and goes 120 m to reach the park. What is the distance between his house and the park?

**Option 1:**

80 m

**Option 2:**

120 m

**Option 3:**

20 m

**Option 4:**

100 m

**Correct Answer:**

100 m

**Solution:**

Firstly, we will draw the diagram as per the given instructions –

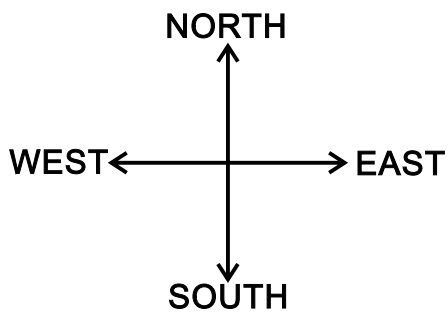

In the figure, A is the starting point and F is the finishing point. So, AF is the distance between the house and the park.

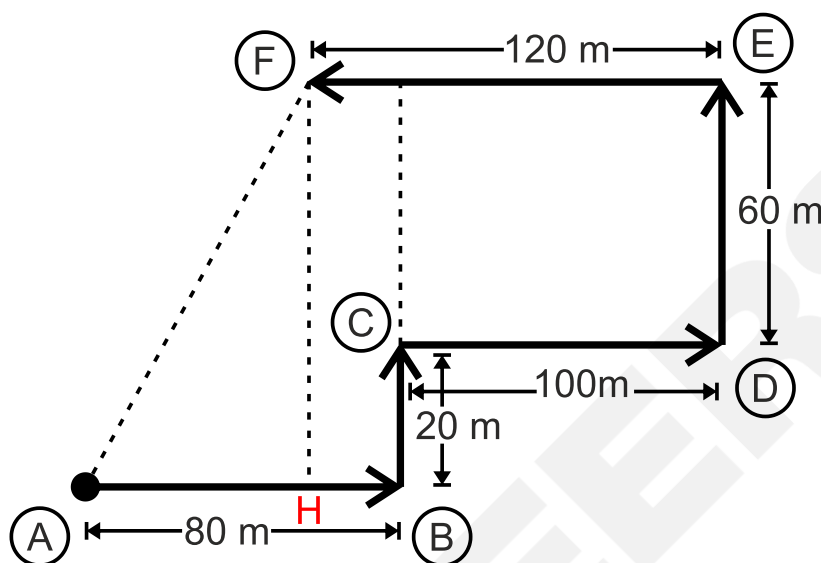

By applying the Pythagoras theorem -

$$(AF)^2 = (AH)^2 + (HF)^2 = (80)^2 + (80)^2 = 6400 + 6400 = 12800$$

$$\Rightarrow (AF)^2 = 12800$$

$$\Rightarrow AF = 113.14 \text{ m}$$

So, the distance between the house and the park is 113.14 m. Hence, the **fourth option** is correct.

**Q.  
115**

**Directions:** Karthik travelled 3 km east, then took a right turn and travelled 4 km. How far is he from the starting point?

**Option 1:**

5 km

**Option 2:**

15 km

**Option 3:**

3 km

**Option 4:**

7 km

**Correct Answer:**

5 km

**Solution:**

Firstly, we will draw the diagram as per the given instructions –

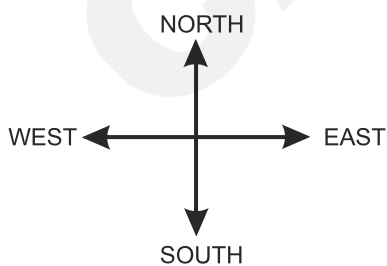

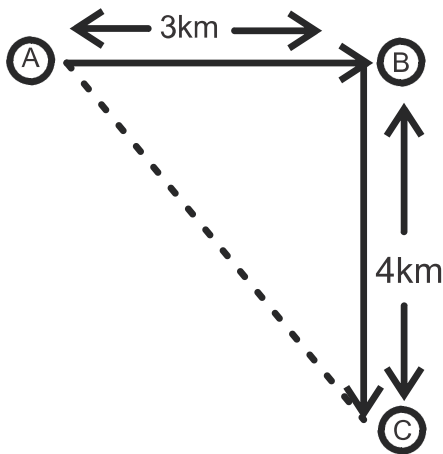

Here,  $AB = 3$  km and  $BC = 4$  km

$AC$  is the distance between the starting and the finishing point.

By applying the Pythagoras theorem -

$$\Rightarrow (AC)^2 = (AB)^2 + (BC)^2 = (3)^2 + (4)^2 = 9 + 16 = 25$$

$$\Rightarrow AC = \sqrt{25} = 5 \text{ km}$$

So, Karthik is 5 km away from the starting point. Hence, the **first option** is correct.

**Q.**  
**116**

**Directions:** Raju faces North and moves 20 km, then he turns to his right and moves 20 km and then he moves 10 km in North-East, then he turns to his right and moves 20 km and then he turns to his right and moves 20 km and again he turned to his left and moves 20 km. Now in which direction Raju is facing?

**Option 1:**

South-East

**Option 2:**

North-East

**Option 3:**

South-West

**Option 4:**

North-West

**Correct Answer:**

South-East

**Solution:**

Firstly, we will draw the diagram as per the given instructions –

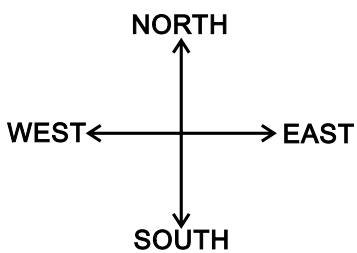

Now, we have to find the direction in which Raju is facing.

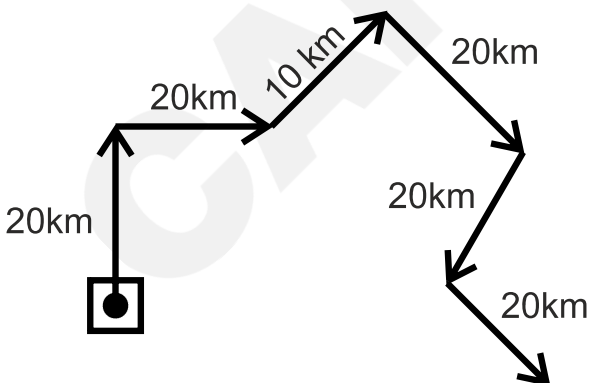

So, Raju is facing the South-East direction. Hence, the **first option** is correct.

**Q.  
117**

**Directions:** Reshma keeps her back towards the rising sun, Reshma starts walking. After a few minutes, she turns left and keeps on walking. Then a little later she turns right and then left. In which direction is she going at the moment?

**Option 1:**  
South

**Option 2:**  
North

**Option 3:**  
West

**Option 4:**  
East

**Correct Answer:**  
South

**Solution:**

Firstly, we will draw the diagram as per the given instructions –

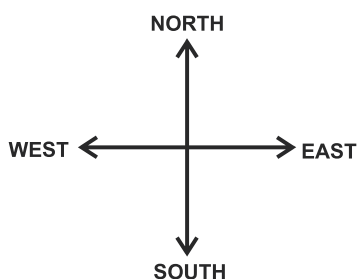

Reshma was moving keeping her back towards the rising sun, i.e., she was moving in the west direction.

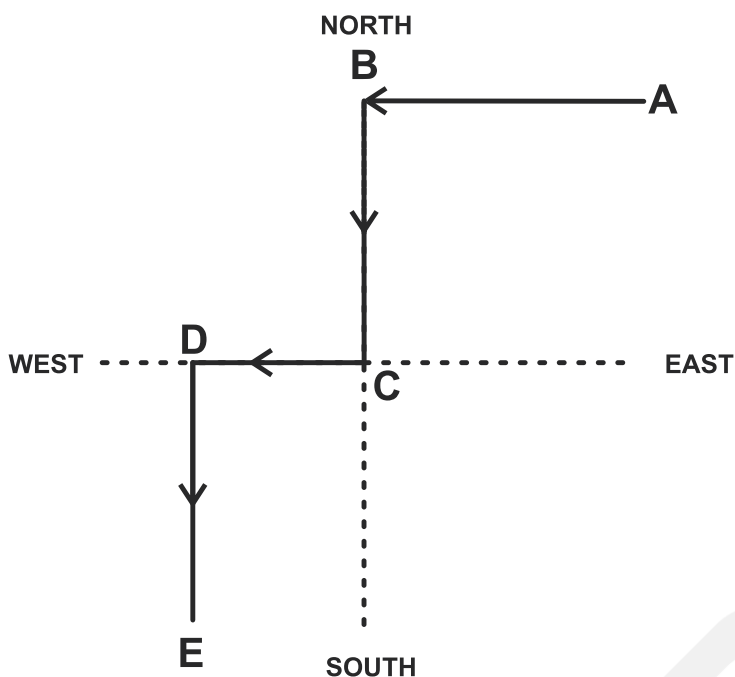

Reshma walks from A to B and faces the West direction, then she takes a left turn and walks from B to C and faces the South direction, then she takes her right from C to D and faces the West direction, and at last, she takes left and walks from D facing the South.

So, Reshma is going in the South direction. Hence, the **first option** is correct.

**Q.**  
**118**

**Directions:** A man drives his car 50 km towards the eastward direction. He turned right and went for 30 km. Then he turned west and drove for 10 km. How far is he from the starting point?

**Option 1:**

50 km

**Option 2:**

60 km

**Option 3:**

100 km

**Option 4:**

20 km

**Correct Answer:**

50 km

**Solution:**

Firstly, we will draw the diagram as per the given instructions –

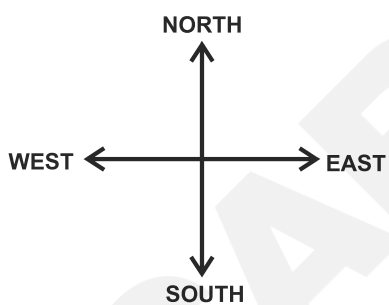

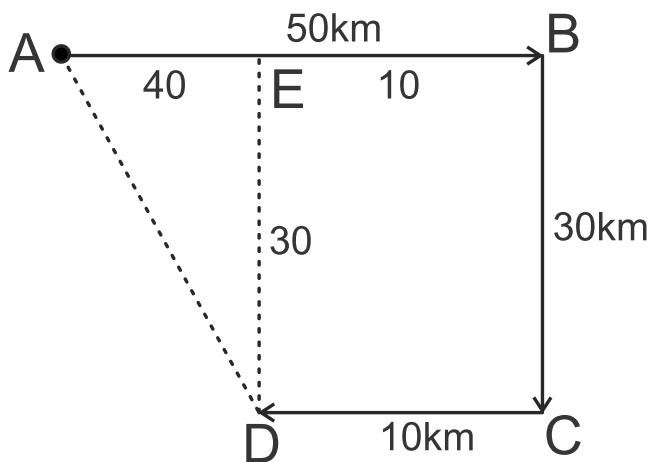

Here, A is the starting point and D is the finishing point of the car. AD is the distance from the starting point.

By applying the Pythagoras theorem -

$$(AD)^2 = (AE)^2 + (ED)^2$$

$$(AD)^2 = (40)^2 + (30)^2$$

$$(AD)^2 = 1600 + 900$$

$$(AD)^2 = 2500$$

$$AD = 50 \text{ km}$$

So, the man is 50 km from the starting point. Hence, the **first option** is correct.

**Q.**  
**119**

**Directions:** Leela starts from a point and walks 1 km east and then turns left and walks 2 km and turns right and walks 2 km again. She starts towards a point 2 km towards her right, from where again she walks 1 km left. How far is she from her starting point?

**Option 1:**

3 km

**Option 2:**

4 km

**Option 3:**

5 km

**Option 4:**

2 km

**Correct Answer:**

4 km

**Solution:**

Firstly, we will draw the diagram as per the given instructions –

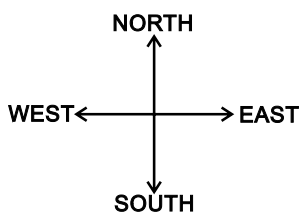

Now, we have to find the distance between Leela's starting position and final position.

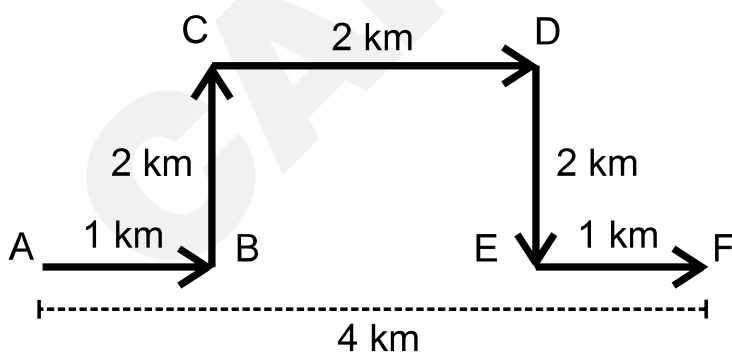

The distance between Leela's starting position (A) and final position (F)  
= 4 km

So, the required distance is 4 km. Hence, the **second option** is correct.

**Q.  
120**

**Directions:** My friend and I started simultaneously towards each other from two places 100 m apart. After walking 30 m, my friend turns left and goes 10 m, then he turns right and goes 20 m and then turns right again and comes back to the road on which he had started walking. If we walk at the same speed, what is the distance between us at this point?

**Option 1:**

50 m

**Option 2:**

20 m

**Option 3:**

30 m

**Option 4:**

40 m

**Correct Answer:**

20 m

**Solution:**

Firstly, we will draw the diagram as per the given instructions –

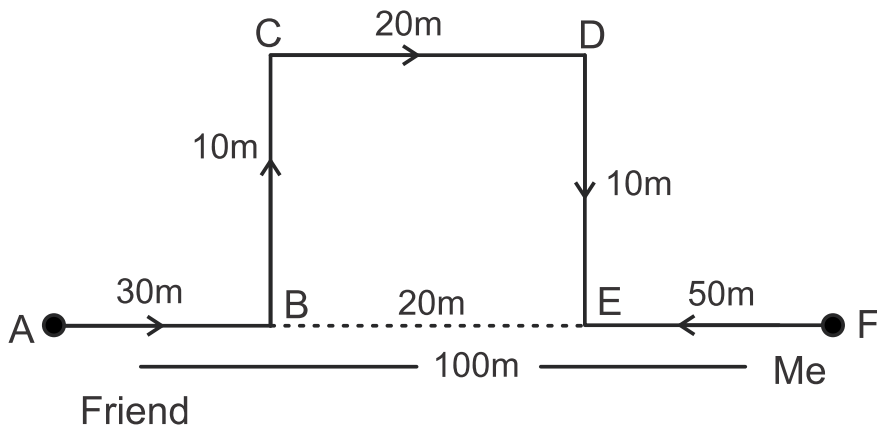

In the above figure, the friend is denoted by A and I is denoted by F.  
Here,  $AF = 100\text{ m}$ ;  $CD = BE = 20\text{ m}$

Total distance covered by a friend  $\Rightarrow AB + BC + CD + DE$   
 $\Rightarrow 30 + 10 + 20 + 10 = 70\text{ m}$

Total distance covered by me =  $EF = 50\text{ m}$

So, we walk at the same speed, then the distance between us at point E -

$\Rightarrow$  total distance covered by a friend - total distance covered by me  
 $\Rightarrow 70 - 50 = 20\text{ m}$

So, the total distance between us is 20 m. Hence, the **second option** is correct.

**Q.**  
**121**

**Directions:** Rama left home and walked 5 km southwards turned right and walked 2 km and turned right and walked 5 km. Then turned left and walked 5 km. How many kilometres will she have to walk to reach her home straight?

**Option 1:**

5

**Option 2:**

7

**Option 3:**

17

**Option 4:**

15

**Correct Answer:**

7

**Solution:**

Firstly, we will draw the diagram as per the given instructions and then find the distance between the starting point(A) and the endpoint (E) covered by Rama –

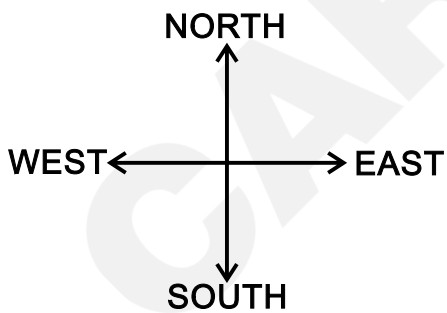

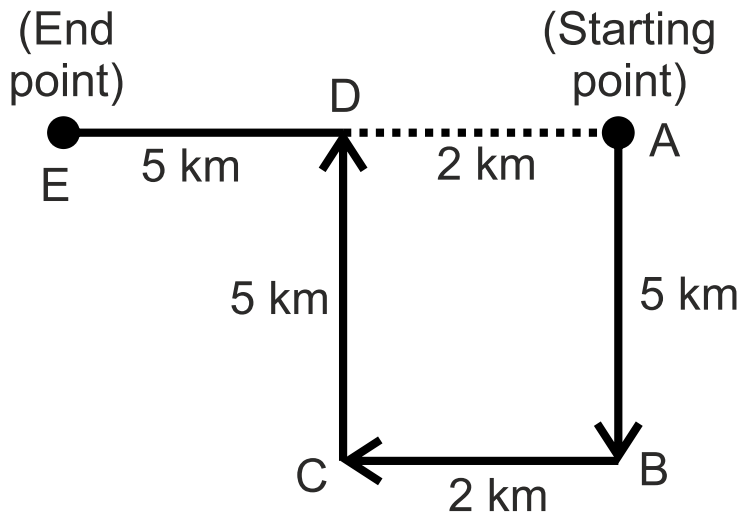

From the above diagram,  $AB = CD = 5$  km;  $BC = AD = 2$  km;  $DE = 5$  km

$$AE = AD + DE$$

$$AE = 2 + 5 = 7 \text{ km}$$

So, Rama needs to walk 7 km straight to reach her home. Hence, the **second option** is correct.

**Q.**  
**122**

**Directions:** Vikram started from point R and walked straight 7 km west, then turned left and walked 2 km, and again turned left and walked straight 4 km. In which direction is he from his starting point?

**Option 1:**  
North-East

**Option 2:**  
South-West

**Option 3:**

South-East

**Option 4:**

North-West

**Correct Answer:**

South-West

**Solution:**

Firstly, we will draw the diagram as per the given instructions –

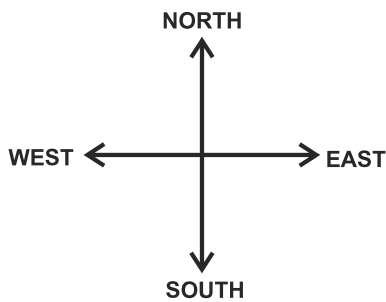

Now, we have to find the direction from Vikram's starting point (R) to his final point (P).

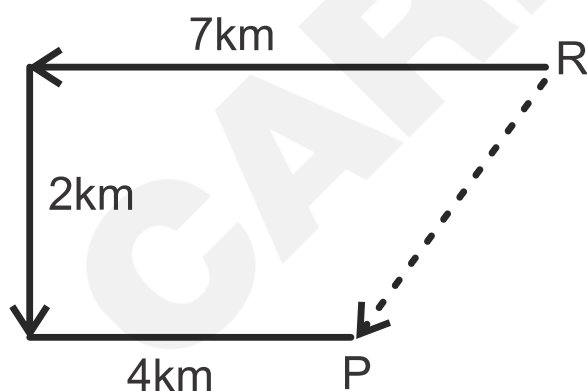

So, from the above diagram, Vikram is in the south-West direction concerning his starting point. Hence, the **second option** is correct.

**Q.  
123**

**Directions:** A boat moves from a jetty towards the east. After sailing for 9 nautical miles, it turns towards the right and covers another 12 nautical miles. If it wants to go back to the jetty what is the shortest distance now from its present position?

**Option 1:**

21 nautical miles

**Option 2:**

20 nautical miles

**Option 3:**

18 nautical miles

**Option 4:**

15 nautical miles

**Correct Answer:**

15 nautical miles

**Solution:**

Firstly, we will draw the diagram as per the given instructions –

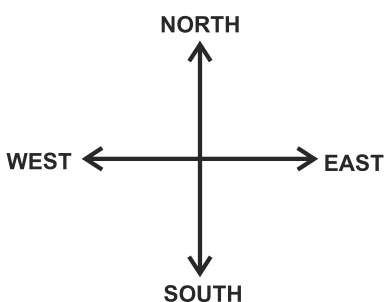

Now, we have to find the shortest distance from the starting point to the endpoint.

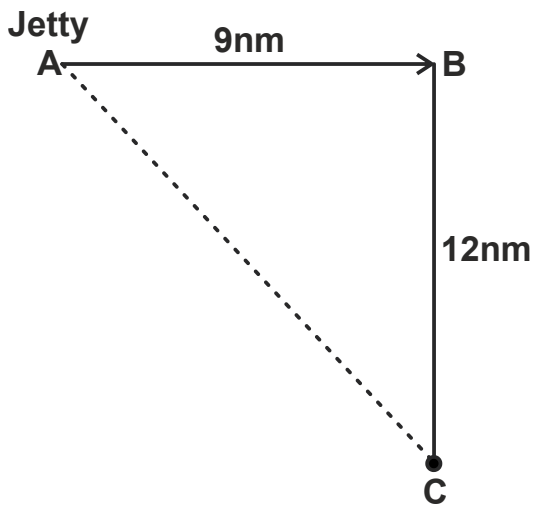

Here, A is the starting point and C is the finishing point of the boat.

AB = 9 nautical miles and BC = 12 nautical miles

AC is the shortest distance for the boat to reach the jetty.

By applying the Pythagorean theorem:

$$(AC)^2 = (AB)^2 + (BC)^2$$

$$(AC)^2 = (9)^2 + (12)^2$$

$$(AC)^2 = 81 + 144 = 225$$

$$AC = 15$$

So, the shortest distance is 15 nautical miles. Hence, the **fourth option** is correct.

**Q.  
124**

**Directions:** A person starts delivering letters 3 km southwards and then turns right. He covers 4 km on this road and again turns right. He delivers letters for 3 km and completes his daily beat. Then he turns left for lunch at home which is 5 km away. How far does he have to travel to reach the post office after lunch?

**Option 1:**  
15 km

**Option 2:**  
10 km

**Option 3:**  
9 km

**Option 4:**  
8 km

**Correct Answer:**  
9 km

**Solution:**

Firstly, we will draw the diagram as per the given instructions –

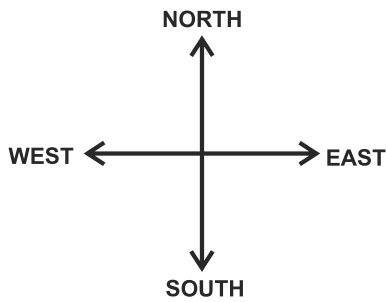

Now, we have to find the distance the person has to travel to reach the post office after lunch.

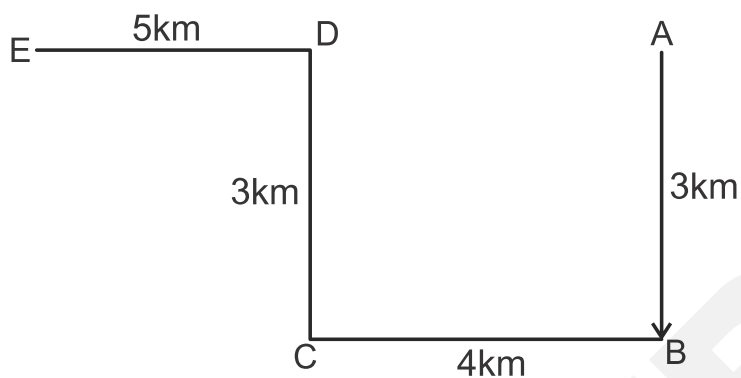

In the figure, A is the starting point and E is the finishing point. So, AE is the distance from the starting point.

Here,  $AB = CD = 3 \text{ km}$  and  $BC = AD = 4 \text{ km}$

So,  $AE = AD + DE$

$\Rightarrow AE = 4 + 5 = 9 \text{ km}$

So, the person has to travel 9 km to reach the post office after lunch. Hence, the **third option** is correct.

**Q.**  
**125**

**Directions:** Arjun starts from school and walks 4 km towards the west, turns right, and walks 3 km. Then he planned to return to school but only through the shortest path. What is the shortest distance between the school and the point where he stopped?

**Option 1:**

3 km

**Option 2:**

16 km

**Option 3:**

25 km

**Option 4:**

5 km

**Correct Answer:**

5 km

**Solution:**

Firstly, we will draw the diagram as per the given instructions –

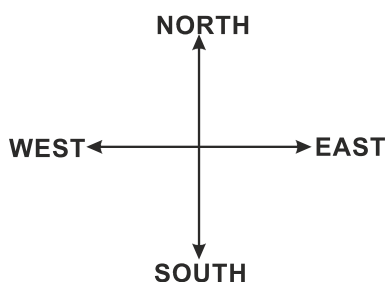

Now, we have to find the shortest distance from the starting point and to the endpoint travel by Arjun.

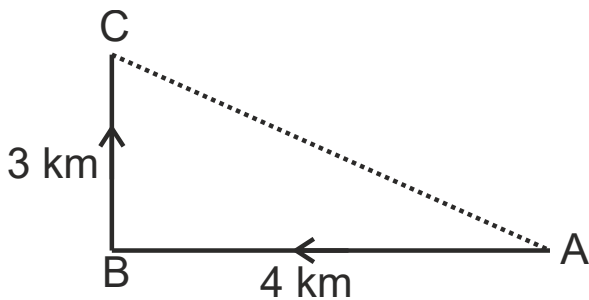

Here, A is the starting point and C is the finishing point of Arjun.

By applying the Pythagoras theorem -

$$(AC)^2 = (AB)^2 + (BC)^2$$

$$(AC)^2 = (4)^2 + (3)^2$$

$$(AC)^2 = 16 + 9$$

$$(AC) = 25$$

$$AC = 5$$

So, the shortest distance between the Arjun and the school is 5 km. Hence, the **fourth option** is correct.

**Q.**  
**126**

**Directions:** From her home facing Southwest, Kavita walks 15 m turns Northward, and walks 12 m. How far was she from her home which was her starting point?

**Option 1:**

10 m

**Option 2:**

9 m

**Option 3:**

15 m

**Option 4:**

12 m

**Correct Answer:**

9 m

**Solution:**

Firstly, we will draw the diagram as per the given instructions –

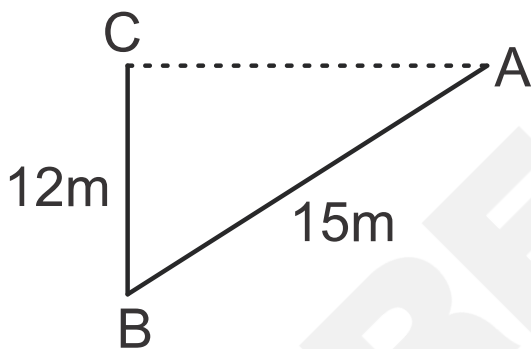

In the above figure, A is the starting point and C is the finishing point of Kavita.

By applying the Pythagoras theorem –

$$(AC)^2 = (AB)^2 - (BC)^2$$

$$(AC)^2 = (15)^2 - (12)^2$$

$$(AC)^2 = 225 - 144$$

$$(AC)^2 = 81$$

$$AC = 9$$

So, the distance between Kavita and her home is 9 m. Hence, the **second option** is correct.

**Q.**  
**127**

**Directions:** A man starts the journey from home. He goes 5 km to the north, then proceeds 10 km to the right. From there he again turns right and goes 10 km. How far is he from home?

*Option 1:*

$$\sqrt{200}$$

*Option 2:*

$$\sqrt{150}$$

*Option 3:*

$$\sqrt{225}$$

*Option 4:*

$$\sqrt{125}$$

**Correct Answer:**

$$\sqrt{125}$$

**Solution:**

Firstly, we will draw the diagram as per the given instructions –

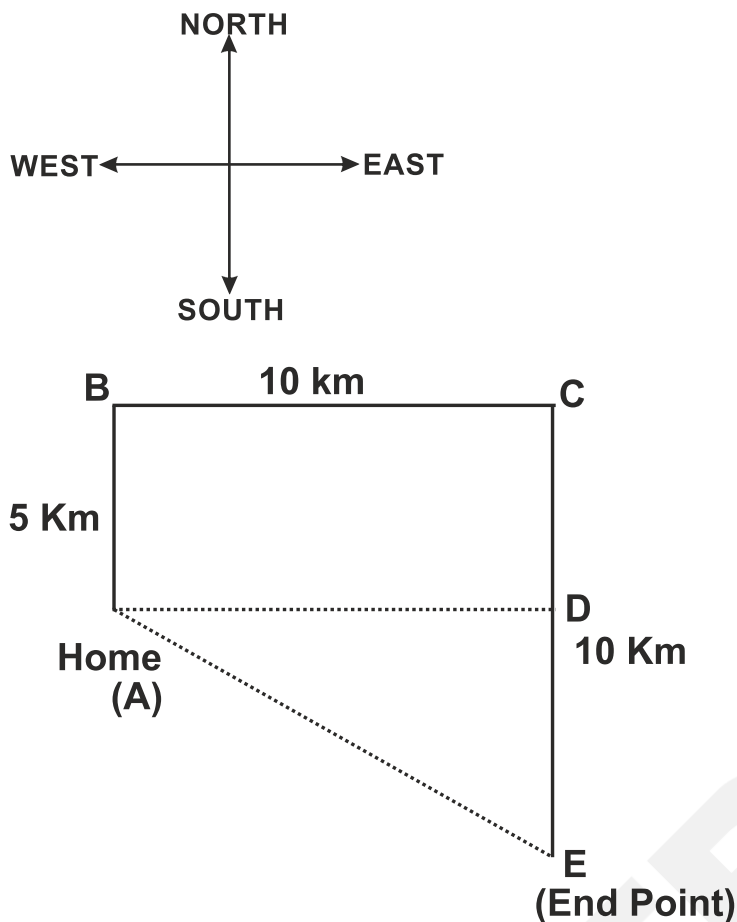

In the above figure, A is the starting point and E is the finishing point of the man.

AE is the distance between the man and his home.

Here,  $BC = AD = 10 \text{ km}$ ;  $AB = DC = 5 \text{ km}$ ;  $DE = 10 - 5 = 5 \text{ km}$

By applying the Pythagoras theorem -

$$(AE)^2 = (AD)^2 + (DE)^2$$

$$(AE)^2 = (10)^2 + (5)^2$$

$$(AE)^2 = 100 + 25$$

$$\Rightarrow AE = \sqrt{125} \text{ km}$$

So, the distance between the man and his home is  $\sqrt{125} \text{ km}$ . Hence, the **fourth option** is correct.

**Q.**  
**128**

**Directions:** Abhinav started running from his house, he first ran for 12 km towards the west, then turned towards the north and ran 16 km in that direction. How far is Abhinav from his house, and in which direction?

**Option 1:**

13 km south

**Option 2:**

13 km North

**Option 3:**

15 km West

**Option 4:**

20 km North-West

**Correct Answer:**

20 km North-West

**Solution:**

Firstly, we will draw the diagram as per the given instructions –

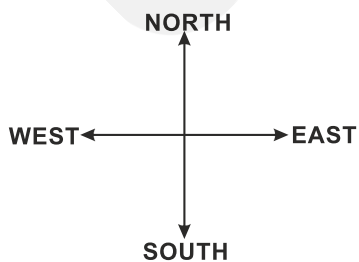

Now, we will find the distance between Abhinav's final position and his house.

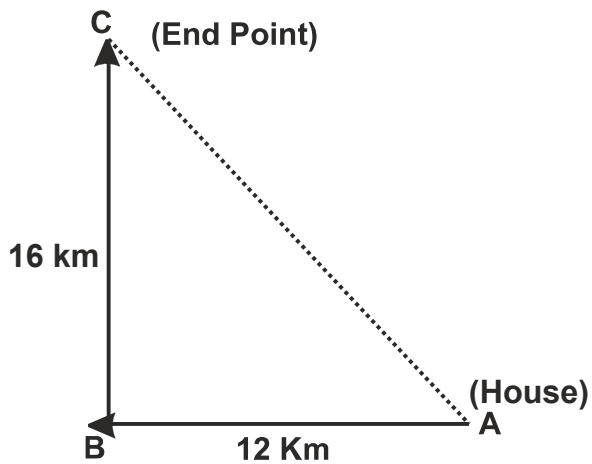

By applying the Pythagoras theorem -

$$AC^2 = AB^2 + BC^2$$

$$AC^2 = 12^2 + 16^2$$

$$AC^2 = 144 + 256$$

$$AC^2 = 400$$

$$AC = 20$$

So, Abhinav is 20 km far in the North-West direction from his house. Hence, the **fourth option** is correct.

**Q.**  
**129**

**Directions:** From point D, Sarita walks 50 metres to the north, then, after turning to the right, walks 50 metres. She again turned right and walked another 70 metres, and finally turned right and walked 50 metres. In which direction and at what distance is she from the starting point D?

**Option 1:**

20 metres to the North

**Option 2:**

40 metres to the South

**Option 3:**

20 metres to the south

**Option 4:**

30 metres to the south

**Correct Answer:**

20 metres to the south

**Solution:**

Firstly, we will draw the diagram as per the given instructions –

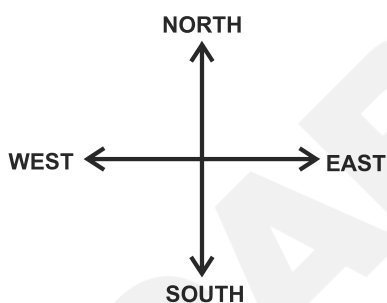

Now we have to find the distance and direction between Sarita's Initial and final point.

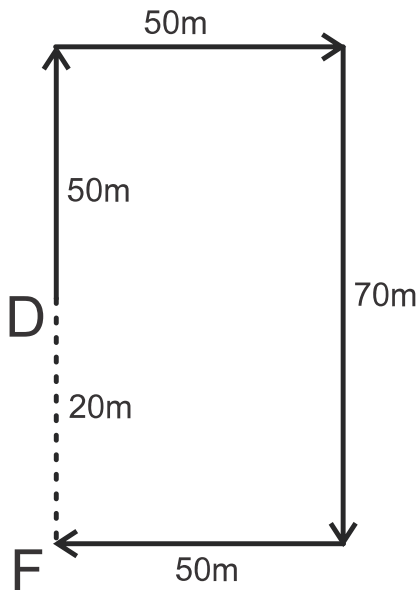

From the above diagram, D is the initial point and F is the final point.

So, Sarita is 20 m to the South from her starting point. Hence, the **third option** is correct.

**Q.**  
**130**

**Directions:** In a square-shaped field A, B, C, and D persons are standing at the middle of each side. You have to bear in mind the directions to be followed as shown in the figure.

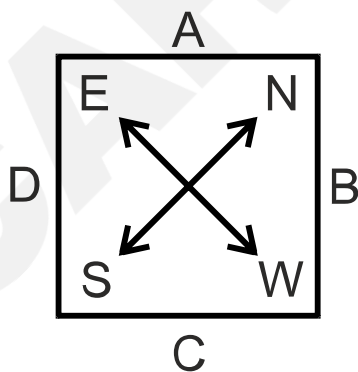

If A moves clockwise  $2\frac{1}{2}$  sides and D moves anti-clockwise  $2\frac{1}{2}$  sides, they will be in which direction?

**Option 1:**

South and West region

**Option 2:**

North and East region

**Option 3:**

South and North region

**Option 4:**

North and West Region

**Correct Answer:**

South and North region

**Solution:****Given:**A moves clockwise  $2\frac{1}{2}$  sides and D moves anti-clockwise  $2\frac{1}{2}$  sides.

Their movement is shown below –

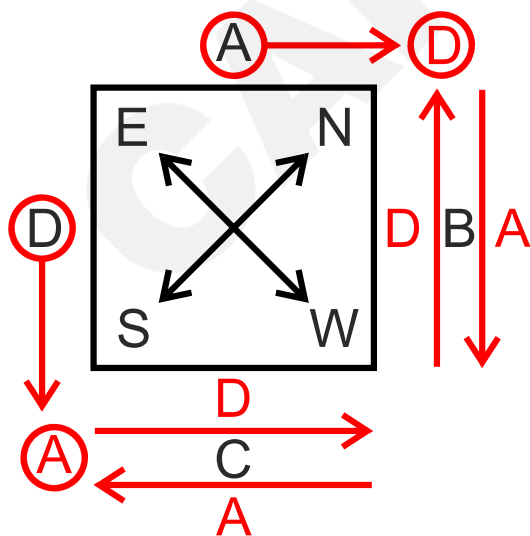

When A moves clockwise  $2\frac{1}{2}$  sides, A is in the south direction.

When D moves anti-clockwise  $2\frac{1}{2}$  sides, D is in the north direction.

So, A and D are in the South and North direction respectively. Hence, the **third option** is correct.

**Q.  
131**

**Directions:** Seeta starts from a point, walks 2 km towards the north, turns towards her right, walks 2 km, turns right again, and walks. What is the direction she is facing now?

**Option 1:**  
East

**Option 2:**  
West

**Option 3:**  
South

**Option 4:**  
North

**Correct Answer:**  
South

**Solution:**

Firstly, we will draw the diagram as per the given instructions –

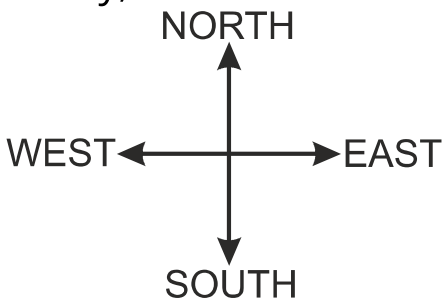

Now, we have to find the direction Seeta is facing now –

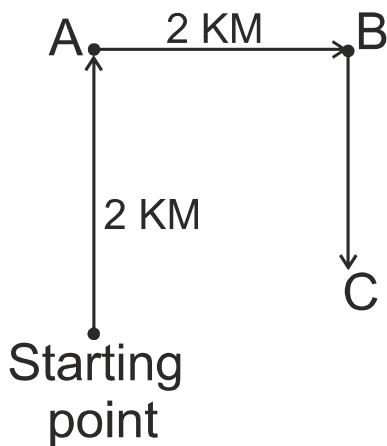

So, Seeta is facing in the south direction. Hence, the **third option** is correct.

**Q.**  
**132**

**Directions:** Deepa starts walking northwards and after a while, she turns to her right. After walking some distance, she turns to her left and walks a distance of one kilometre. She then turns to her left again. In which direction is she moving now?

**Option 1:**

North

**Option 2:**

West

**Option 3:**

East

**Option 4:**

South

**Correct Answer:**

West

**Solution:**

Firstly, we will draw the diagram as per the given instructions –

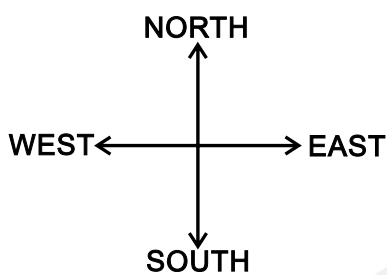

Now, we need to find the directions where Deepa is moving now.

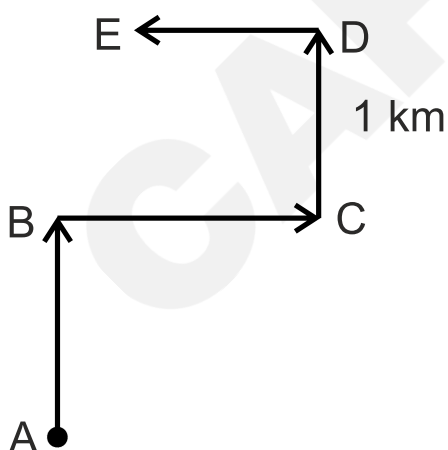

So, Deepa is moving in the west direction. Hence, the **second option** is correct.

**Q.  
133**

**Directions:** A man walks 7 km towards the north before taking a left turn and walking a further 5 km then he takes a left turn and walks 15 km. Finally, he takes a left turn again and walks 5 km. How much distance is he away from the starting point?

**Option 1:**

8 km

**Option 2:**

12 km

**Option 3:**

15 km

**Option 4:**

22 km

**Correct Answer:**

8 km

**Solution:**

Firstly, we will draw the diagram as per the given instructions –

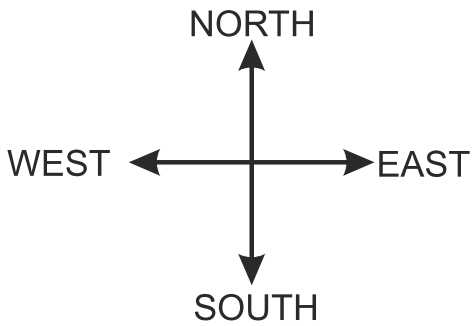

Now, we have to find the distance between starting and endpoints. Here, A is the starting point and E is the endpoint.

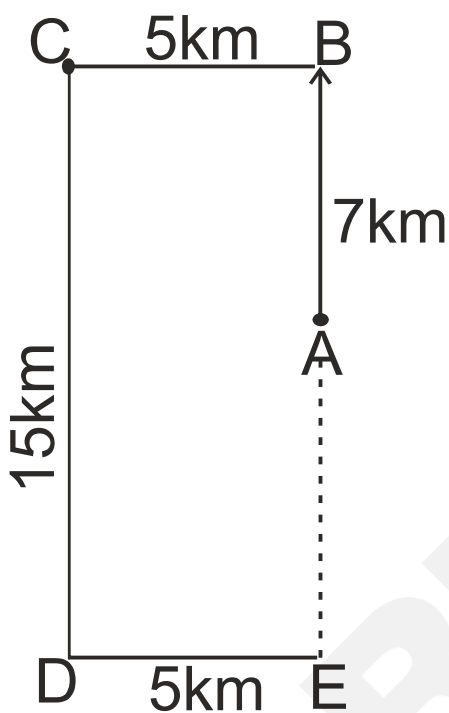

Distance between starting and endpoints →

$$AE = DC - AB$$

$$AE = 15 - 7$$

$$AE = 8 \text{ km}$$

So, the distance between the starting and endpoints is 8 km. Hence, **the first option** is correct.

**Q.  
134**

**Directions:** Sabmitra walks 4 km towards the north, turns right, and walks 5 km. Then he turns towards the south and walks 2 km. Again he takes a turn towards the west walks 3 km and stops for a while. Then he walked 2 km. What is the distance of Sabmitra from the starting point?

**Option 1:**

16 km

**Option 2:**

2 km

**Option 3:**

4 km

**Option 4:**

3 km

**Correct Answer:**

2 km

**Solution:**

Firstly, we will draw the diagram as per the given instructions –

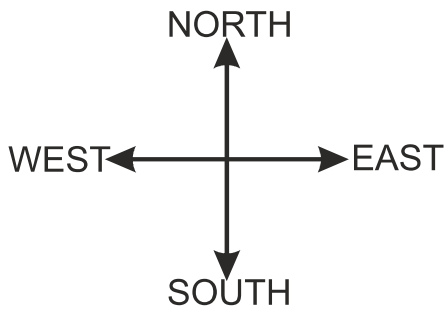

Now, we have to find the distance between starting and endpoints.

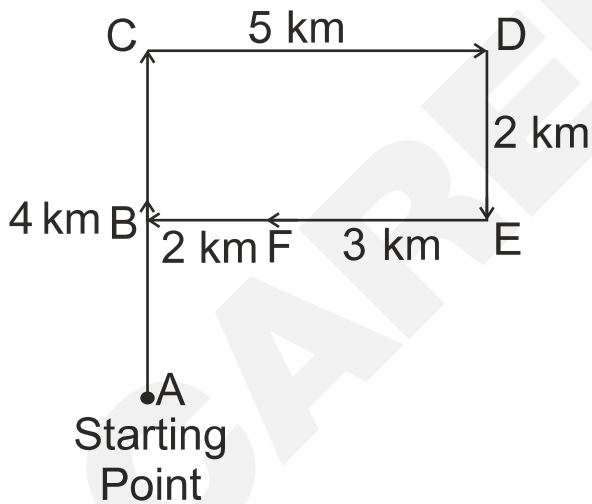
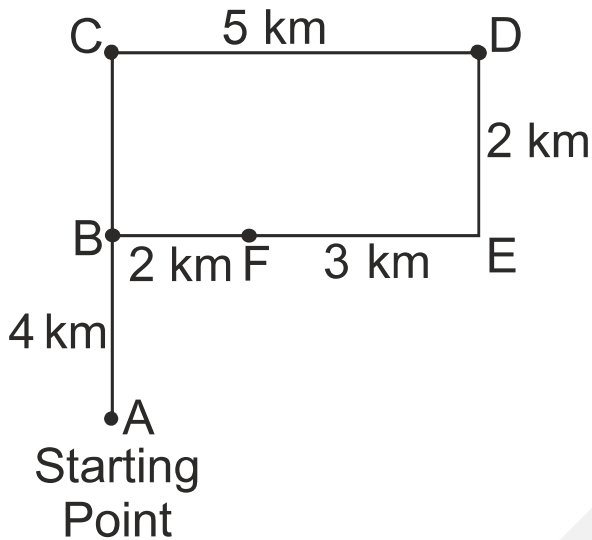

The endpoint is B, and B is the midpoint of CA, and  $CB = DE$ .

$$BA = CA - CB$$

$$BA = 4 - 2$$

$$BA = 2 \text{ km}$$

So, the distance between the starting point and the endpoint is 2 km.  
Hence, the **second option** is correct.

**Q.  
135**

**Directions:** Neha departs from her home and walks 51 m towards the south and then turns left and walks 44 m. Now she turns left again and walks 83 m. How far is she from a pole that is exactly 32 m north of her home now? (Assuming that all turns are  $90^\circ$  turns only.)

**Option 1:**

14 m

**Option 2:**

44 m

**Option 3:**

7 m

**Option 4:**

39 m

**Correct Answer:**

44 m

**Solution:**

Firstly, we will draw the diagram as per the given instructions –

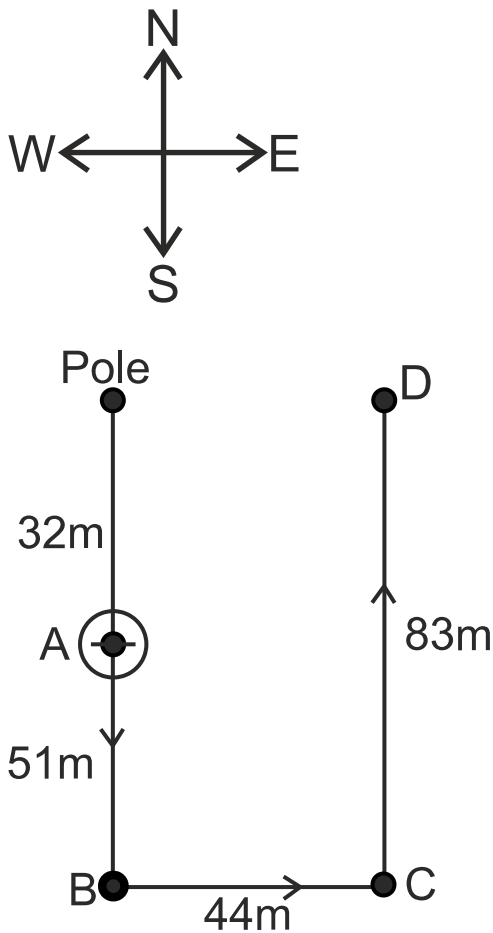

Here, A is the starting point and D is the endpoint.

Thus, the distance between the pole and Neha's endpoint is 44 m.

So, Neha is 44 m away from the pole. Hence, the **second option** is correct.

**Q.**  
**136**

**Directions:** Suman drives 3 km towards north from point A. She takes a right turn and drives 4 km more. Then she takes another right turn and drives 3 km. Finally, she takes one more right turn and drives 6 km to reach point B. How far and towards which direction should she drive to reach point A again?

**Option 1:**

2 km towards the south

**Option 2:**

3 km towards the north

**Option 3:**

3 km towards the west

**Option 4:**

2 km towards the east

**Correct Answer:**

2 km towards the east

**Solution:**

First, we will draw the diagram, as per the given instructions –

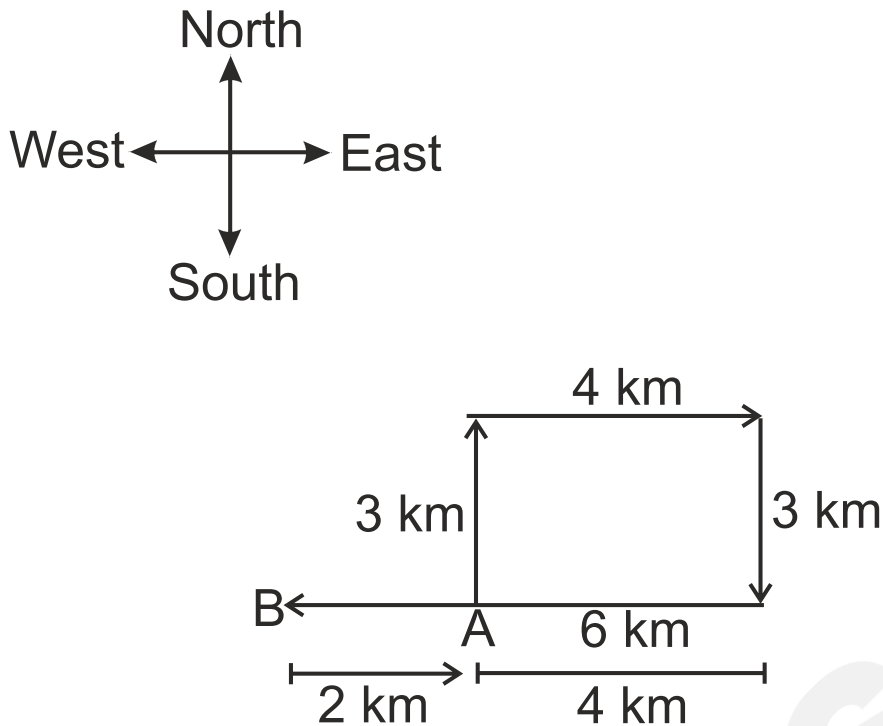

Here, A is the starting point and B is the end point.

To reach point A again from B, Suman should drive 2 km towards the East. Hence, the **fourth option** is correct.

**Q.**  
**137**

**Directions:** Ahmet's house faces north. He came out of his house and walked straight for 40 m, turned left, and walked for 30 m. He then, turned right and walked for 35 m. Finally, he took another two successive right turns and covered 30 m and 25 m respectively, to reach his final destination. How far and in which direction is he from his house now?

**Option 1:**

25 m due south

**Option 2:**

50 m due north

**Option 3:**

15 m due north

**Option 4:**

25 m due east

**Correct Answer:**

50 m due north

**Solution:**

First, we will draw the diagram, as per the given instructions –

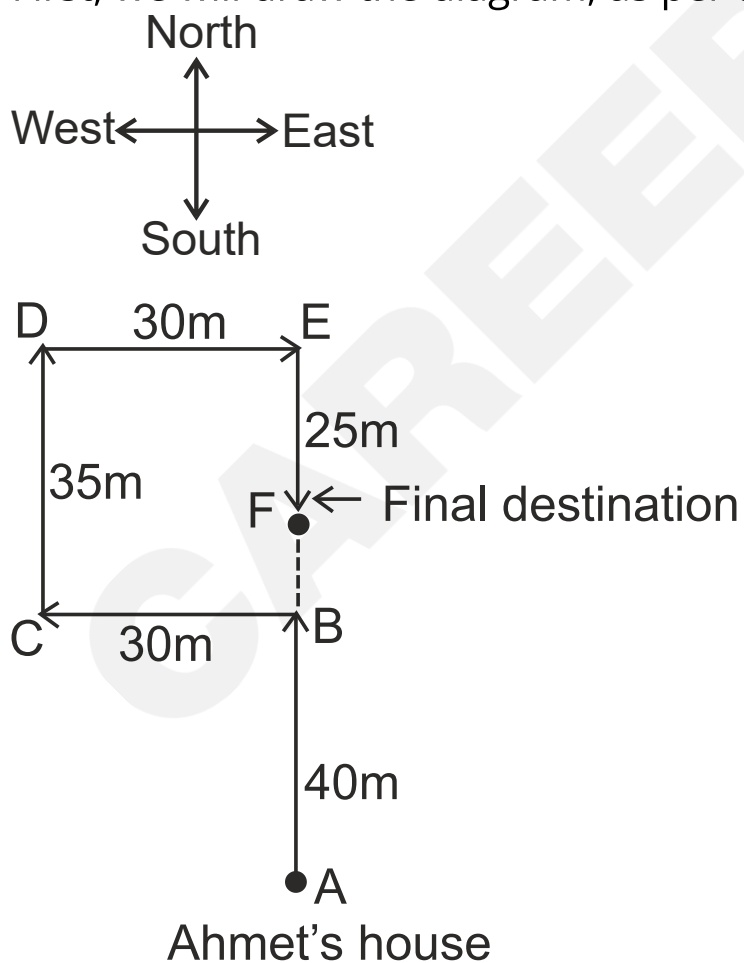

Here, A is the starting point and F is the finishing point.

$$AB = 40 \text{ m}; CD = 35 \text{ m}; EF = 25 \text{ m}$$

$$BF = CD - EF$$

$$BF = 35 - 25$$

$$BF = 10 \text{ m}$$

Now, find the distance between his final position (F) and his house (A) –

$$AF = AB + BF$$

$$AF = 40 + 10$$

$$AF = 50 \text{ m}$$

So, the distance between his final position and his house is 50 m, and he is in the north direction of his house. Hence, the **second option** is correct.

**Q.  
138**

**Directions:** Deepa starts from her house and cycles 4 km towards the north and then turns left and cycles 6 km. She again turns left and cycles for X km to reach her school. Point A is to the east of her school and also 3 km to the south of her house. What is the value of X?

**Option 1:**

1 km

**Option 2:**

7 km

**Option 3:**

9 km

**Option 4:**

3 km

**Correct Answer:**

7 km

**Solution:**

Firstly, we will draw the diagram as per the given instructions –

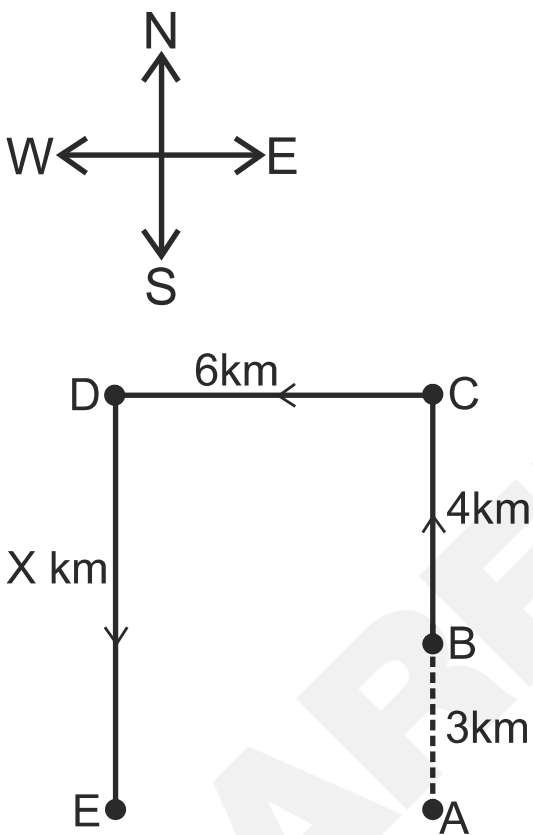

Here, B is the starting point (Deepa's house) and E is the endpoint (Deepa's school).

$AB = 3 \text{ km}$ ;  $BC = 4 \text{ km}$ ;  $CD = 6 \text{ km}$ ;  $DE = X \text{ km}$

As,  $DE = AC$

$AC = AB + BC = 3 + 4 = 7$

So,  $DE = AC = 7 \text{ km}$

Thus, the value of X is 7 km. Hence, the **second option** is correct.

**Q.  
139**

**Directions:** Pratima departs from her house and walks 29 m towards the north, then turns right and walks 16 m. Now she turns right again and walks 17 m. She again, takes a right turn and stops after walking for 21 m. What is the shortest distance between Pratima and her house now? (Assuming that all turns are 90-degree turns only.)

**Option 1:**  
17 m

**Option 2:**  
18 m

**Option 3:**  
13 m

**Option 4:**  
12 m

**Correct Answer:**  
13 m

**Solution:**

First, we will draw the diagram, as per the given instructions –

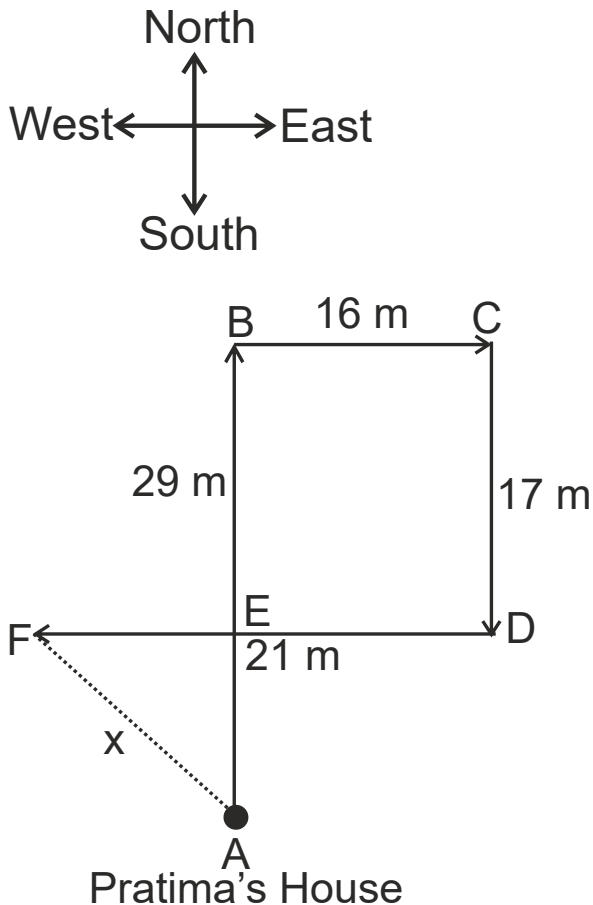

Here, A is the starting point and F is the finishing point.

$AB = 29$  m;  $BC = DE = 16$  m;  $CD = BE = 17$  m;  $DF = 21$  m

And,  $AE = AB - BE$

$$AE = 29 - 17$$

$$AE = 12$$
 m

$$EF = DF - DE$$

$$EF = 21 - 16$$

$$EF = 5$$
 m

By applying the Pythagorean theorem –

$$(AF)^2 = (AE)^2 + (EF)^2$$

$$(x)^2 = (12)^2 + (5)^2 = 144 + 25 = 169$$

$$\Rightarrow AF = \sqrt{169} = 13$$
 m

So, the shortest distance between Pratima and her house is 13 m. Hence, the **third option** is correct.

**Q.  
140**

**Directions:** Rajesh drives 4 km towards the west from point A and then takes a right turn and drives 8 km. He again takes a right turn and drives 8 km. He again takes one more right turn and drives 4 km. Finally, he takes a right turn and drives 4 km to reach point B. How far and towards which direction should he drive to reach point A again?

**Option 1:**

3 km towards the north

**Option 2:**

2 km towards the east

**Option 3:**

4 km towards the south

**Option 4:**

4 km towards the west

**Correct Answer:**

4 km towards the south

**Solution:**

Firstly, we will draw the diagram as per the given instructions –

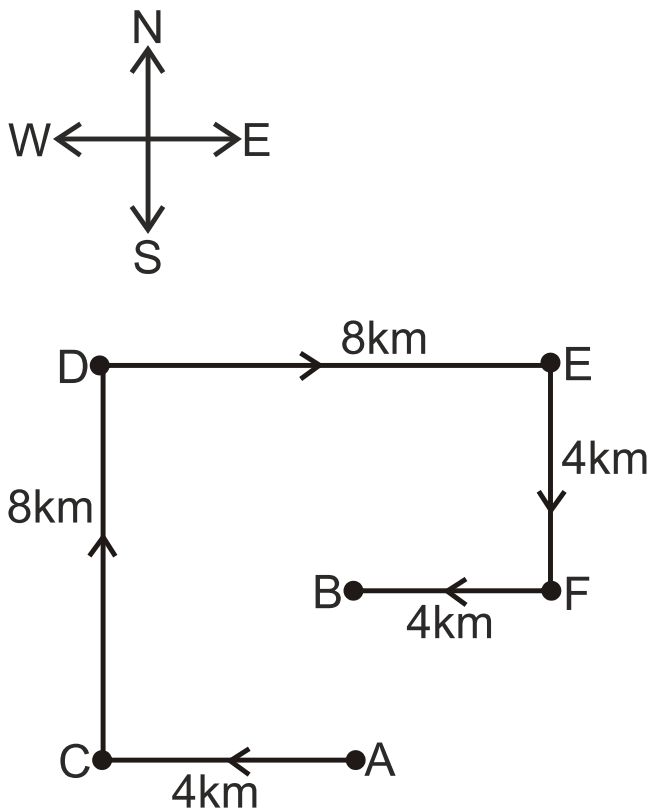

Here, A is the starting point and B is the endpoint.

$AC = 4$  km;  $CD = 8$  km;  $DE = 8$  km;  $EF = 4$  km;  $FB = 4$  km

Now, find the distance between the starting point and the endpoint -

$$AB = CD - EF = 8 - 4 = 4 \text{ km}$$

So, Rajesh should drive 4 km towards the south to reach point A. Hence, the **third option** is correct.

**Q.**  
**141**

**Directions:** Diogo's house faces west. He steps out of his house and walks 22 m straight. He then turns to his left and walks 20 m. He takes another left turn and walks 25 m. Finally, he turns left once again and walks further for 24 m to reach his school. How far is the school from his house and in which direction respect to his house?

**Option 1:**

5 m due north-east

**Option 2:**

7 m due north-east

**Option 3:**

5 m due north-west

**Option 4:**

25 m due south-east

**Correct Answer:**

5 m due north-east

**Solution:**

Firstly, we will draw the diagram as per the given instructions –

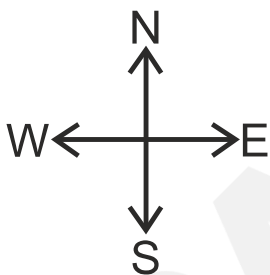

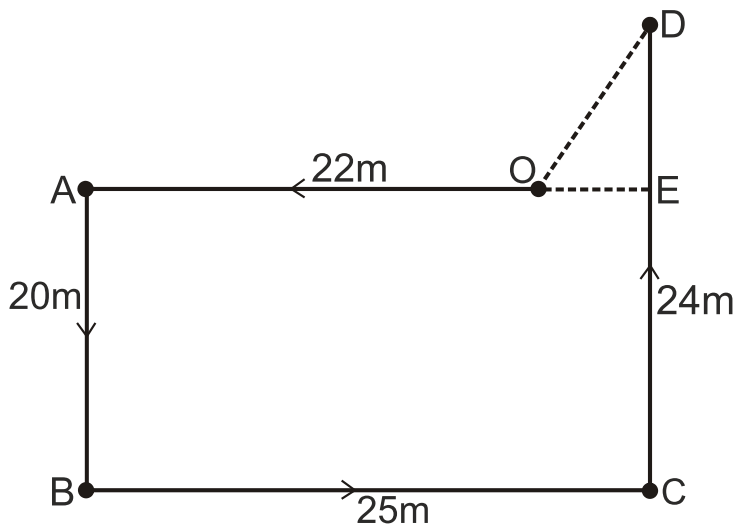

Here, O is the starting point (Diogo's house), and D is the endpoint (Diogo's school).

$AB = 20 \text{ m}$ ;  $BC = 25 \text{ m}$ ;  $CD = 24 \text{ m}$ ;  $OA = 22 \text{ m}$ ;  $EC = AB = 20 \text{ m}$

$DE = CD - EC = 24 - 20 = 4 \text{ m}$ ;  $OE = BC - OA = 25 - 22 = 3 \text{ m}$

By applying the Pythagoras theorem -

$$(OD)^2 = (DE)^2 + (OE)^2$$

$$(OD)^2 = (4)^2 + (3)^2 = 16 + 9 = 25$$

$$\Rightarrow OD = \sqrt{25} = 5 \text{ m}$$

So, Diogo's school is 5 m from his house in the north-east direction. Hence, the **first option** is correct.

**Q.**  
**142**

**Directions:** Anita starts from her house and cycles 6 km towards the south and then turns left and cycles 8 km. She again turns left and cycles for X km to reach her school. Point A is to the west of her school and also 3 km to the north of her house. What is the value of X?

**Option 1:**

9 km

**Option 2:**

3 km

**Option 3:**

7 km

**Option 4:**

11 km

**Correct Answer:**

9 km

**Solution:**

Firstly, we will draw the diagram as per the given instructions –

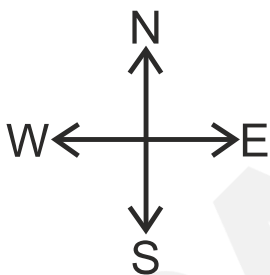

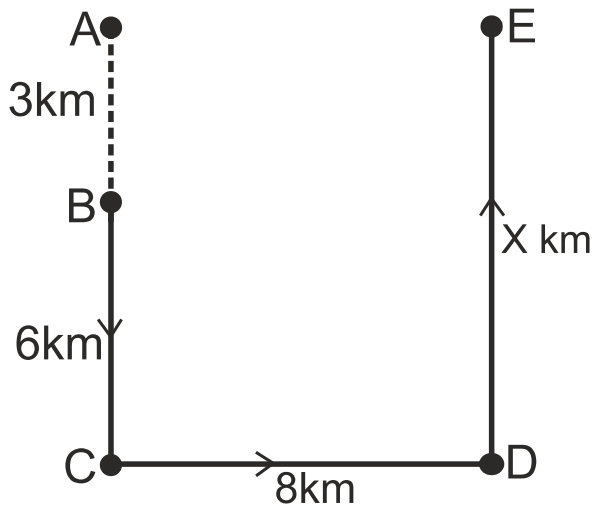

Here, B is the starting point (Anita's house) and E is the endpoint (Anita's school).

$AB = 3 \text{ km}$ ;  $BC = 6 \text{ km}$ ;  $CD = 8 \text{ km}$ ;  $DE = X \text{ km}$

As,  $DE = AC$

$AC = AB + BC = 3 + 6 = 9$

So,  $DE = AC = 9 \text{ km}$

Thus, the value of X is 9 km. Hence, the **first option** is correct.

**Q.**  
**143**

**Directions:** From its nest, a bird flew 25 m towards the north-east. It then took a right turn and flew 7m. Again, it took a right turn and flew 75 m. In which direction is the bird now from its nest?

**Option 1:**

North-East

**Option 2:**

East

**Option 3:**  
South-West

**Option 4:**  
North-West

**Correct Answer:**  
South-West

**Solution:**

Firstly, we will draw the diagram as per the given instructions –

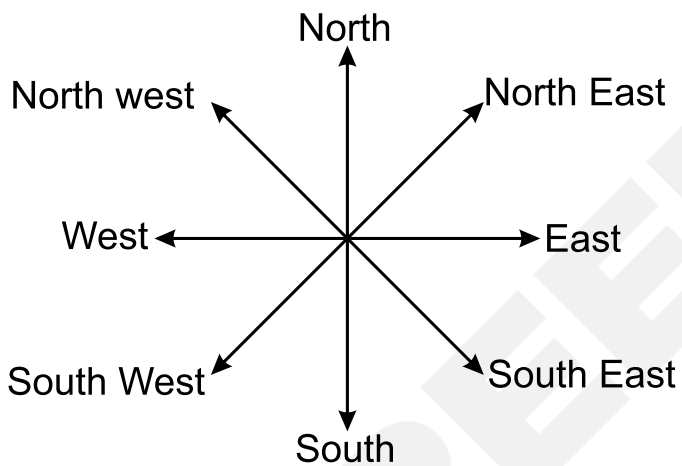

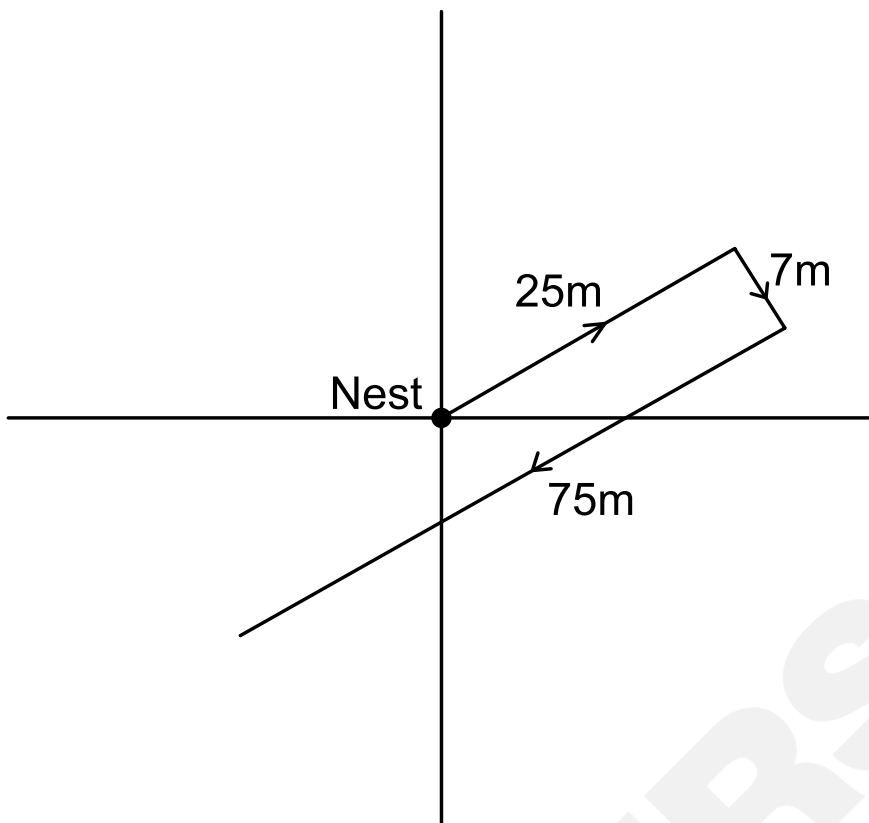

So, the bird is facing in the South-West direction from its nest. Hence, the **third option** is correct.

**Q.  
144**

**Directions:** Reema starts from her house and cycles 4 km towards the west and, then turns right and cycles 6 km. She again, turns right and cycles for X km to reach her school. Point A is to the south of her school, and also 2 km to the west of her house. What is the value of X?

**Option 1:**

6 km

**Option 2:**

8 km

**Option 3:**

2 km

**Option 4:**

4 km

**Correct Answer:**

2 km

**Solution:**

First, draw the diagram, as per the given instructions –

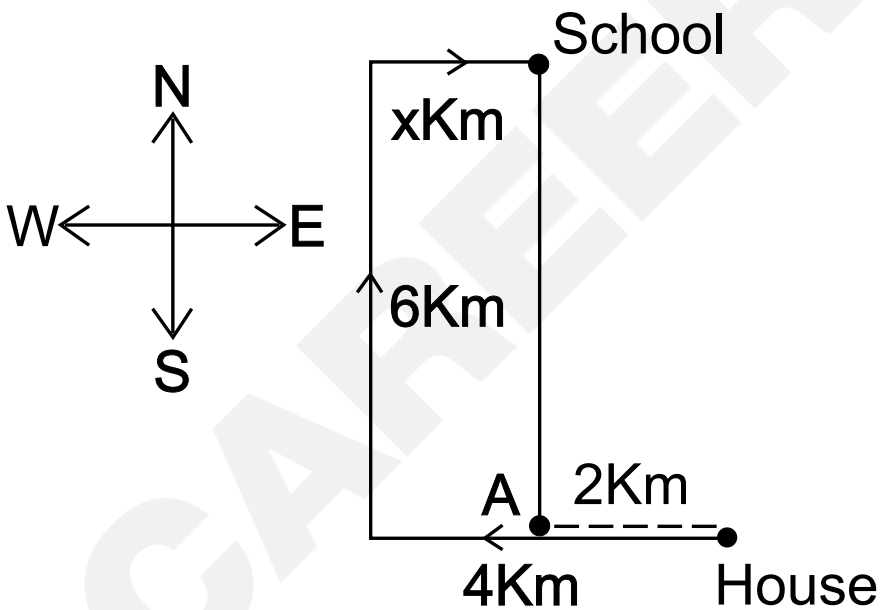

So, the value of  $X = (4 - 2) \text{ km} = 2 \text{ km}$ . Hence, the **third option** is correct.

**Q.  
145**

**Directions:** Rocky starts from point A and drives 3 km towards the east. He takes a left turn and drives 4 km. He again takes a left turn and drives 3 km. He takes one more left turn and then drives 2 km and stops at B. How far and towards which direction should he drive to reach point A again?

**Option 1:**

2 km towards the south

**Option 2:**

3 km towards the south

**Option 3:**

3 km towards the east

**Option 4:**

2 km towards the north

**Correct Answer:**

2 km towards the south

**Solution:**

Firstly, we will draw the diagram as per the given instructions –

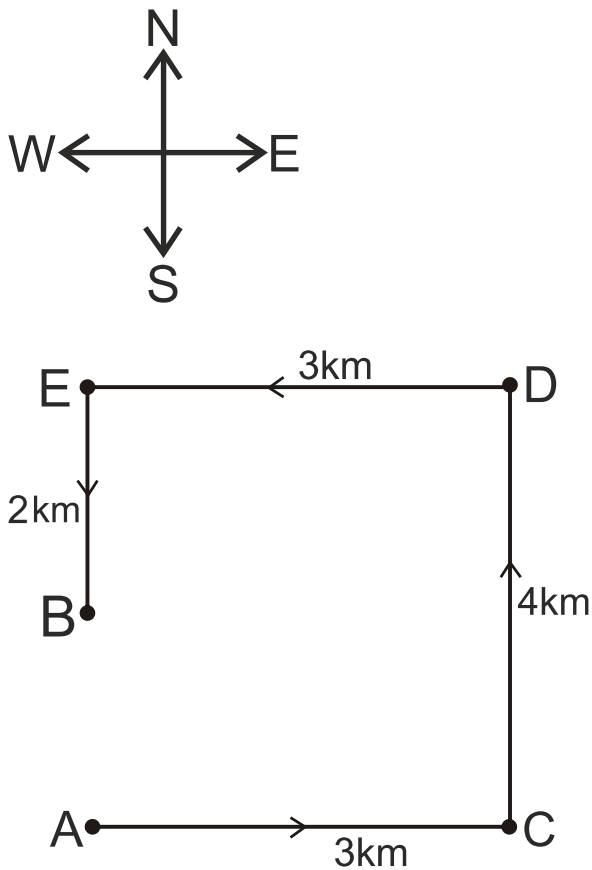

Here, A is the starting point and B is the endpoint.

$AC = 3 \text{ km}$ ;  $CD = 4 \text{ km}$ ;  $DE = 3 \text{ km}$ ;  $EB = 2 \text{ km}$

Now, find the distance between the starting point and the endpoint –

$AB = CD - EB = 4 - 2 = 2 \text{ km}$

So, Rocky should drive 2 km towards the south to reach point A. Hence, the **first option** is correct.

**Q.**  
**146**

**Directions:** City A is located to the North of City B. City D is located to the East of City B. City C is located to the West of City D. City E is located to the South of City C and the SouthWest of City A. What is the position of City B with respect to City C?

**Option 1:**

South

**Option 2:**

West

**Option 3:**

East

**Option 4:**

North

**Correct Answer:**

East

**Solution:**

Firstly, we will draw the diagram as per the given instructions –

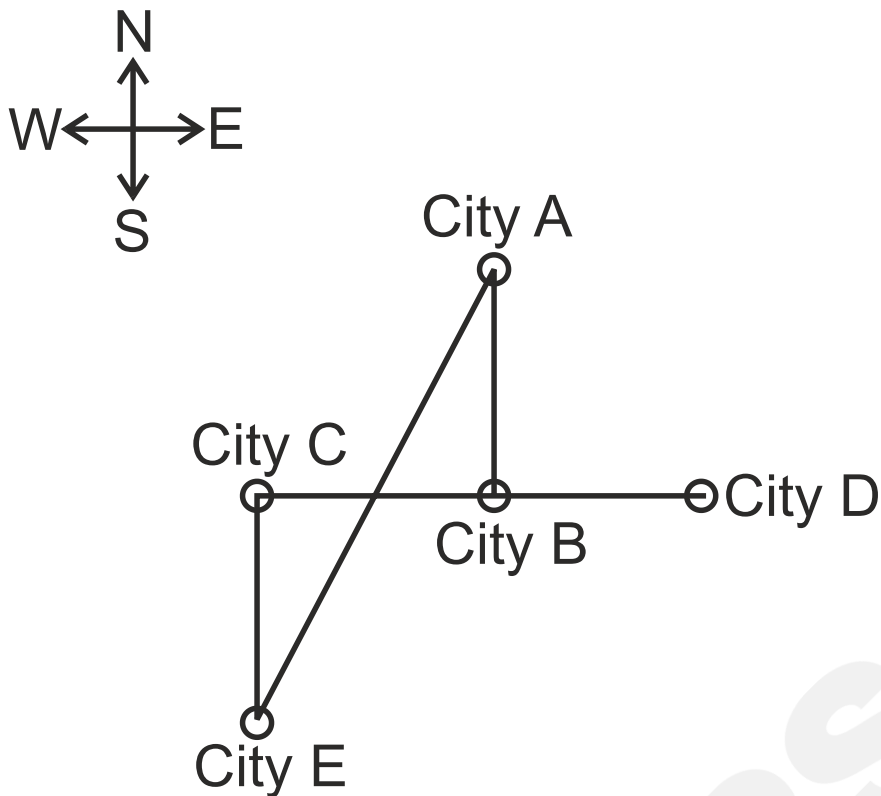

So, City B is to the east of City C. Hence, the **third option** is correct.

**Q.**  
**147**

**Directions:** Ritu drives 2 km towards the south from point A. She takes a right turn and drives 2 km more. She again, takes a right turn and drives 2 km. Finally, she takes one more right turn and drives 4 km to reach point B. How far and towards which direction should she drive to reach point A again?

**Option 1:**

3 km towards east

**Option 2:**

2 km towards west

**Option 3:**

2 km towards south

**Option 4:**

3 km towards north

**Correct Answer:**

2 km towards west

**Solution:**

Firstly, we will draw the diagram as per the given instructions –

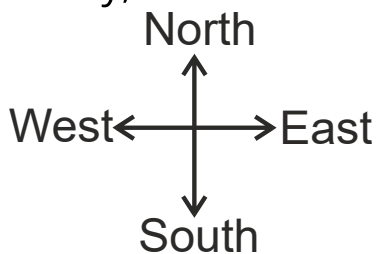

Now, we have to find the distance between A and B and towards which direction should she drive to reach point A again.

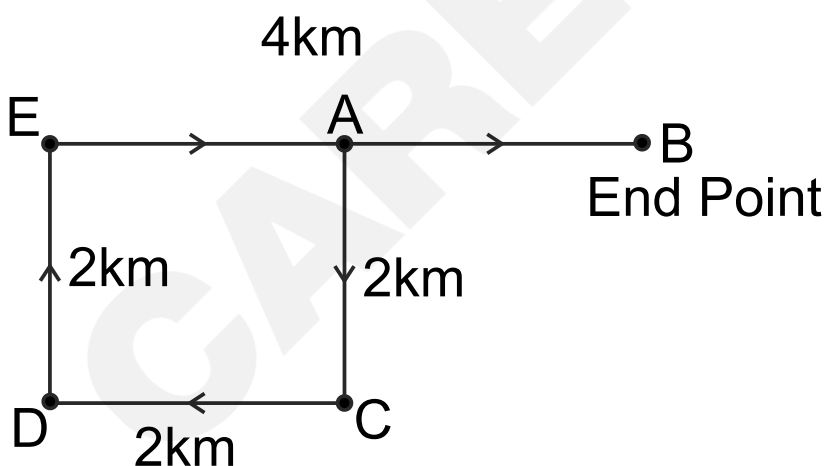

Here, A is the starting point and B is the endpoint.

Distance between AB = BE - EA

$$AB = 4 - 2$$

$$AB = 2 \text{ km}$$

So, the distance between A and B is 2 km and, she has to turn towards the West direction to reach the starting point. Hence, the **second option** is correct.

**Q.  
148**

**Directions:** Mohan's house faces south. He steps out of his house and goes straight for 30 m. From there, he takes two successive right turns and covers a distance of 6 m and 24 m, respectively. Finally, he takes a left turn and walks a distance of 2 m to reach a grocery shop. What is the shortest distance between his house and the grocery shop?

**Option 1:**

12 m

**Option 2:**

6 m

**Option 3:**

8 m

**Option 4:**

10 m

**Correct Answer:**

10 m

**Solution:**

Firstly, we will draw the diagram as per the given instructions –

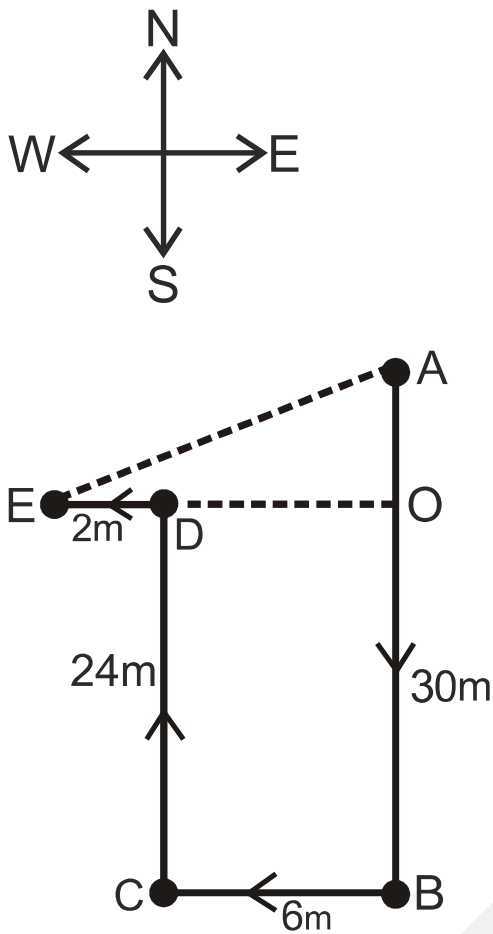

Here, A is the starting point (Mohan's house), and E is the endpoint (Grocery shop).

$$AB = 30 \text{ m}; BC = 6 \text{ m}; CD = 24 \text{ m}; DE = 2 \text{ m};$$

$$OD = BC = 6 \text{ m}; OB = DC = 24 \text{ m}$$

$$OE = OD + DE = 6 + 2 = 8 \text{ m}; OA = AB - OB = 30 - 24 = 6 \text{ m}$$

By applying the Pythagoras theorem –

$$(AE)^2 = (OE)^2 + (OA)^2$$

$$(AE)^2 = (8)^2 + (6)^2 = 64 + 36 = 100$$

$$\Rightarrow AE = \sqrt{100} = 10 \text{ m}$$

So, the shortest distance between Mohan's house and the grocery shop is 10 m. Hence, the **fourth option** is correct.

**Q.  
149**

**Directions:** On a certain day John decided to go to school using his newly purchased skates. So, he left his house and skated 15 km northwards, then turned left and skated 7 km, then he took another left turn and skated 15 km, and then finally turned right and skated 13 km. How far exactly is his school from his house?

**Option 1:**

20 km

**Option 2:**

6 km

**Option 3:**

2 km

**Option 4:**

28 km

**Correct Answer:**

20 km

**Solution:**

Firstly, we will draw the diagram as per the given instructions –

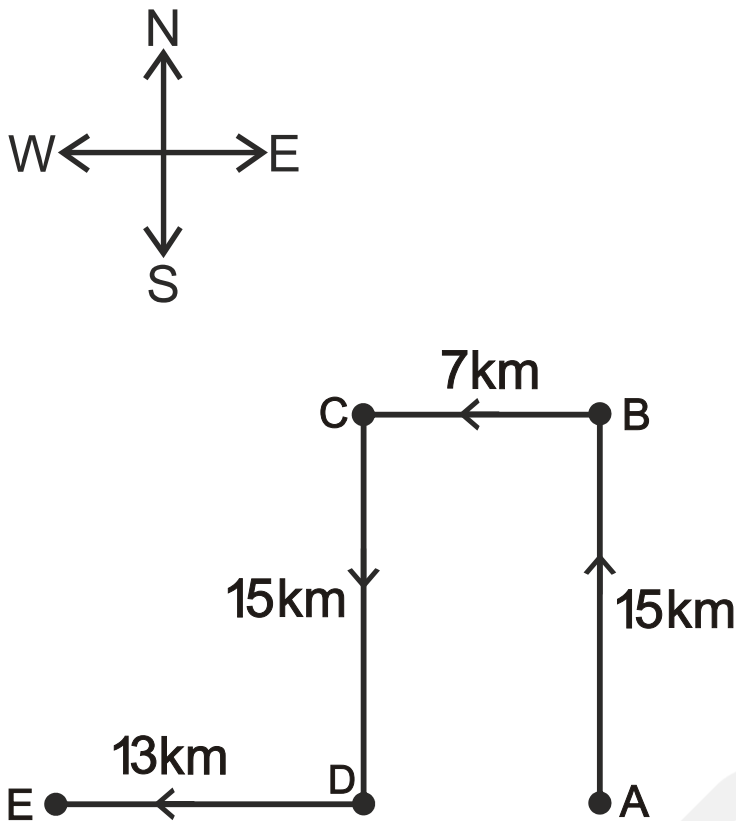

Here, A is the starting point (John's house) and E is the endpoint (John's school).

So, the distance between the starting point and the endpoint is AE.

$$AE = AD + DE = 7 + 13 = 20 \text{ km}$$

So, John's school is 20 km from his house. Hence, the **first option** is correct.

**Q.**  
**150**

**Directions:** Karan drives 6 km towards north from point A. He takes a left turn and drives 3 km. Again he takes a left turn and drives 3 km. He takes a left turn and drives 6 km. He takes a right turn and drives 3 km to reach point B. How far and towards which direction should he drive to reach point A again?

**Option 1:**

5 km towards the east

**Option 2:**

3 km towards the west

**Option 3:**

4 km towards the north

**Option 4:**

2 km towards the south

**Correct Answer:**

3 km towards the west

**Solution:**

Firstly, we will draw the diagram as per the given instructions –

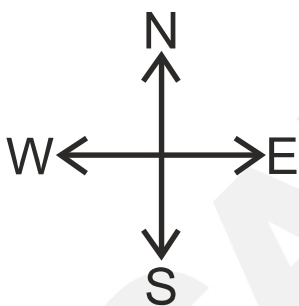

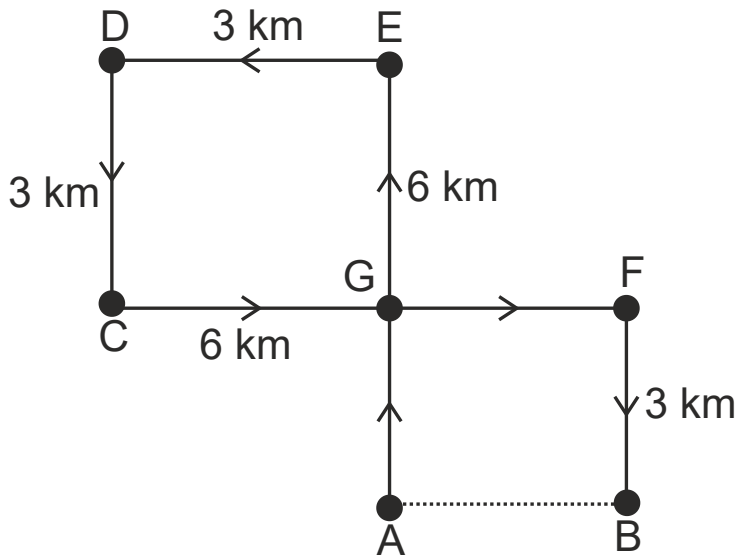

Here, A is the starting point and B is the endpoint.

$$AB = GF = CF - CG$$

$$AB = 6 - 3$$

$$AB = 3 \text{ km}$$

So, he should drive 3 km towards the west to reach point A again.

Hence, the **second option** is correct.