

# **CAREERS** 360

**PRACTICE** **Series**

## **NMAT 2025**

---

# **Sample Paper**

by Hitbullseye

# Contents

## 1. Sample Paper

## 2. Other Useful Resources

- a. 3000+ Most Important Words - Vocabulary Builder
- b. 500+ Most Important Idioms and Phrases
- c. 300+ Most Important Phrasal Verbs
- d. Permutation & Combination - Video Lectures and Practice Questions
- e. Mastering DILR Questions with Expert Solutions

## 3. Computer Based Mock Test

**Directions of Test**

<b>Test Name</b>	Diagnostic Test - NMAT	<b>Total Questions</b>	108	<b>Total Time</b>	120 Mins
------------------	------------------------	------------------------	-----	-------------------	----------

<b>Section Name</b>	<b>No. of Questions</b>	<b>Time limit</b>	<b>Marks per Question</b>	<b>Negative Marking</b>
Verbal	36	0:28(h:m)	3	0
Quantitative Ability	36	0:52(h:m)	3	0
Logical Reasoning	36	0:40(h:m)	3	0

**Section : Verbal**

**DIRECTIONS for the question:** Sentences given in the each, question, when properly sequenced form a coherent paragraph. Each sentence is labelled with a letter. Choose the most logical order of sentences from among the four/five given choices to construct a coherent paragraph.

**Question No. : 1**

- A. Stopping on the way to work in order to watch, for a while, some relatively unusual spectacle — a film being shot, an accident or a fight — and then moving on with a sort of light, passing amusement is part of the texture of everyday Indian life.  
B. This Hollywood couple's public profile in India is becoming increasingly unsavoury.  
C. But perhaps it is time to cultivate a degree of robust uncuriosity, a healthy lack of inquisitiveness that lets people get on with their own work — even if they happen to be Angelina Jolie and Brad Pitt.  
D. That might be the only way to put celebrity hubris firmly in place — as Pitt and Jolie's thoroughly deserve.  
E. Little diversions are always welcome in India.

A) ECABD B) AEADB C) DAEB C D) EABCD E) EACDB

**DIRECTIONS for the question:** Sentences given in the each, question, when properly sequenced form a coherent paragraph. Each sentence is labelled with a letter. Choose the most logical order of sentences from among the four/five given choices to construct a coherent paragraph.

**Question No. : 2**

- A. "Muhammad Gullistan visited the house while her family was away," police officer Qaisar Abbas said.  
B. A Pakistani man shot dead his teenage niece because she was listening to loud music, police said today.  
C. "He asked her to turn the music down but she refused and they had an argument. He shot her with a 33-bore pistol."  
D. Women are murdered every day in Pakistan for perceived slights against conservative social traditions.  
E. Muhammad Gullistan, 30, found his niece alone at her home on Sunday in Chakwal, 90km southeast of Islamabad.

A) ABCDE B) BECDA C) BEDCA D) BEACD E) CABDE

**DIRECTIONS for the question:** Sentences given in the each, question, when properly sequenced form a coherent paragraph. Each sentence is labelled with a letter. Choose the most logical order of sentences from among the four/five given choices to construct a coherent paragraph.

**Question No. : 3**

- A. Ivory dominates, but also on offer are polar bear rugs, snow leopards' teeth and a £55,000 cup fashioned from a rhino's horn.
- B. The trade in animal products is just as vigorous.
- C. For those seeking a more manageable purchase, there are emerald boas, hummingbirds or poison dart frogs available by the dozen.
- D. The world's endangered wildlife is for sale on the world wide web: live tigers, bears, orangutans and chimpanzees are all just a few clicks away.

A) ACDB   B) DACB   C) CADB   D) DCBA   E) CDAB

**DIRECTIONS for the question:** Sentences given in the each, question, when properly sequenced form a coherent paragraph. Each sentence is labelled with a letter. Choose the most logical order of sentences from among the four/five given choices to construct a coherent paragraph.

**Question No. : 4**

- A. He has impressed the leaders of most Asian countries, of the United States of America and the United Kingdom, as well as of Australia.
- B. In the process, he has depicted the broad contours of his foreign policy.
- C. Narendra Modi as prime minister has had an outstanding record overseas.
- D. These include emphasizing India's role in Asia and developing deep economic, trade and investment bonds, particularly with moneyed nations like Japan and China.

A) ABDC   B) CBAD   C) CADB   D) CABD   E) DABC

**DIRECTIONS for the question:** Choose the word from the options which is **Opposite** in meaning to the given word.

**Question No. : 5**

SCABROUS

- A) level   B) unkind   C) stubborn   D) pitiless   E) stable

**DIRECTIONS for the question:** Choose the word from the options which is **Opposite** in meaning to the given word.

**Question No. : 6**

PINNACLE

- A) Nadir   B) Inferior   C) Climax   D) Current   E) Apogee

**DIRECTIONS for the question:** Choose the word from the options which is **Opposite** in meaning to the given word.

**Question No. : 7**

WAVER

- A) Grasp   B) Persist   C) Despicable   D) Unruly   E) Dither

**DIRECTIONS for the question:** Choose the word from the options which is most **Similar** in meaning to the given word.

**Question No. : 8**

BLAZE

- A) explosion    B) touchiness    C) perceptiveness    D) inferno    E) ignition

**DIRECTIONS for the question:** Choose the word from the options which is most **Similar** in meaning to the given word.

**Question No. : 9**

REMISS

- A) coarse    B) ominous    C) slipshod    D) dinghy    E) jagged

**DIRECTIONS for the question:** Choose the word from the options which is most **Similar** in meaning to the given word.

**Question No. : 10**

AUDACITY

- A) Entwine    B) Pokerfaced    C) Boldness    D) Wantonness    E) Shamelessness

**DIRECTIONS for the question:** Select the correct meaning of the italicized idioms and phrases out of the four choices given.

**Question No. : 11**

What does the phrase 'with a flea in one's ear' mean?

- A) To know mysteries    B) To cause nuisance    C) To be rebuked    D) To compliment someone    E) To create problem

**DIRECTIONS for the question:** Choose the pair of words which best expresses the relationship similar to that expressed in the capitalized pair.

**Question No. : 12**

IMPLACABLE: APPEASE:: \_\_\_\_\_ : \_\_\_\_\_

- A) invincible : appeal    B) inconsistent : argue    C) unconquerable : subdue    D) perturbable : agitate  
E) stubborn : pamper

**DIRECTIONS for the question:** Choose the pair of words which best expresses the relationship similar to that expressed in the capitalized pair.

**Question No. : 13**

INDULGE:ASCETIC:: \_\_\_\_\_ : \_\_\_\_\_

- A) convince : leader    B) honest : politician    C) restrain : debauched    D) defeat : conspirator    E) obey : sponsor

**DIRECTIONS for the question:** The paragraph below has blank, each blank indicating that a word that has been omitted. Blank also carries the question number the particular blank refers to. Beneath the paragraph, the question follow. You are to choose the one word that, when inserted into the sentence, BEST fits in with the meaning of the sentence and paragraph as a whole.

**Question No. : 14**

The star-struck silliness is \_\_\_\_\_. From ordinary citizens to the administration, school authorities and, most importantly, the media, all are willing to let go of discrimination and restraint, and make every sort of \_\_\_\_ with rules, laws and basic human decency in order to accommodate the celebrities' inflated sense of their own importance. The bedazzled eagerness with which allowances and arrangements are made by the highest authorities to \_\_\_\_\_ to arbitrary demands and whims speaks of a deep-rooted 'VIP mentality', which is pegged up a few notches in the case of non-native VIP. It is sometimes heart-warming to be unselfconsciously inquisitive and accommodating. But it is never nice to be told, however implicitly, that some people deserve rude, self-important and \_\_\_\_\_ behaviour.

- A) illusory B) pervasive C) deceptive D) ephemeral E) transitory

**DIRECTIONS for the question:** The paragraph below has blank, each blank indicating that a word that has been omitted. Blank also carries the question number the particular blank refers to. Beneath the paragraph, the question follow. You are to choose the one word that, when inserted into the sentence, BEST fits in with the meaning of the sentence and paragraph as a whole.

**Question No. : 15**

The star-struck silliness is \_\_\_\_\_. From ordinary citizens to the administration, school authorities and, most importantly, the media, all are willing to let go of discrimination and restraint, and make every sort of \_\_\_\_\_ with rules, laws and basic human decency in order to accommodate the celebrities' inflated sense of their own importance. The bedazzled eagerness with which allowances and arrangements are made by the highest authorities to \_\_\_\_\_ to arbitrary demands and whims speaks of a deep-rooted 'VIP mentality', which is pegged up a few notches in the case of non-native VIP. It is sometimes heart-warming to be unselfconsciously inquisitive and accommodating. But it is never nice to be told, however implicitly, that some people deserve rude, self-important and \_\_\_\_\_ behaviour.

- A) observation B) negotiation C) cooperation D) talks E) compromise

**DIRECTIONS for the question:** The paragraph below has blank, each blank indicating that a word that has been omitted. Blank also carries the question number the particular blank refers to. Beneath the paragraph, the question follow. You are to choose the one word that, when inserted into the sentence, BEST fits in with the meaning of the sentence and paragraph as a whole.

**Question No. : 16**

The star-struck silliness is \_\_\_\_\_. From ordinary citizens to the administration, school authorities and, most importantly, the media, all are willing to let go of discrimination and restraint, and make every sort of \_\_\_\_ with rules, laws and basic human decency in order to accommodate the celebrities' inflated sense of their own importance. The bedazzled eagerness with which allowances and arrangements are made by the highest authorities to \_\_\_\_\_ to arbitrary demands and whims speaks of a deep-rooted 'VIP mentality', which is pegged up a few notches in the case of non-native VIP. It is sometimes heart-warming to be unselfconsciously inquisitive and accommodating. But it is never nice to be told, however implicitly, that some people deserve rude, self-important and \_\_\_\_\_ behaviour.

- A) enliven B) cater C) hop D) furnish E) restore

**DIRECTIONS for the question:** The paragraph below has blank, each blank indicating that a word that has been omitted. Blank also carries the question number the particular blank refers to. Beneath the paragraph, the question follow. You are to choose the one word that, when inserted into the sentence, BEST fits in with the meaning of the sentence and paragraph as a whole.

**Question No. : 17**

The star-struck silliness is \_\_\_\_(/)\_\_\_\_. From ordinary citizens to the administration, school authorities and, most importantly, the media, all are willing to let go of discrimination and restraint, and make every sort of \_\_\_\_(/)\_\_\_\_ with rules, laws and basic human decency in order to accommodate the celebrities' inflated sense of their own importance. The bedazzled eagerness with which allowances and arrangements are made by the highest authorities to \_\_\_\_(/)\_\_\_\_ to arbitrary demands and whims speaks of a deep-rooted 'VIP mentality', which is pegged up a few notches in the case of non-native VIP. It is sometimes heart-warming to be unselfconsciously inquisitive and accommodating. But it is never nice to be told, however implicitly, that some people deserve rude, self-important and \_\_\_\_\_ behaviour.

- A) highhanded    B) comforting    C) solacing    D) palliative    E) alleviating

**DIRECTIONS for the question:** Replace the underlined/Bold part of the sentence with the best possible choice so as to make the key sentence grammatically correct. If the sentence is all right, i.e. does not require any correction or improvement, tick 1 as your answer.

**Question No. : 18**

Elephants have been an important part of circus acts since the 1800s, and it is still prized as a circus animal by circus managers, who typically involve elephants in acts which portray love and friendliness.

- A) it is still prized as a circus animal by circus managers    B) it is still prized as a circus animals by circus managers  
C) circus managers still prize it as a circus animal    D) they are still prized as circus animals by circus managers  
E) they are still being prized as a circus animal by the circus managers

The question consists of four statements labelled P, Q, R and S which when logically ordered form a coherent passage. Choose the option that represents the most logical order.

**Question No. : 19**

- (P) just when Calcutta,  
(Q) thought that it had been there, seen that and done that,  
(R) the capital of street protests,  
(S) comes an unparalleled event: a protest to champion the cause of thieves.

- A) PQRS    B) QRPS    C) RQSP    D) PRQS    E) None of the above

**DIRECTIONS for the question:** Complete the sentence by filling in the appropriate blank/blanks from the options provided.

**Question No. : 20**

The \_\_\_\_ nature of a person is to reply and retort to someone who is criticizing his actions, even though the person may be aware that it was his mistake in the first place and the criticism was not uncalled for.

- A) specific    B) capricious    C) primal    D) pragmatic    E) hardnosed

**DIRECTIONS for the question:** The questions below have three sentences, with each sentence having one blank. Beneath the sentence are six lettered words which are labeled A, B, C, D, E and F. Out of these words, three would fit the blanks given. You are to choose the sequence of words that best fits the three sentences (the first word of the sequence is for the first sentence, the second word of the sequence is for the second sentence and the third word of the sequence is for the third sentence).

**Question No. : 21**

- (I) The story of the poor woodcutter who discovered a thieves' den full of treasure may have come from Syria or Cyprus; it certainly did not come \_\_\_ India.
- (II) Travel in India may be exciting, unexpected, troublesome, romantic, incredible, \_\_\_ embarking on the adventure has always been forbidding, for getting a visa is often like getting a ticket to the moon.
- (III) Things might change somewhat with the electronic travel authorization and the expansion of the visa-on-arrival schemes that the Centre has decided \_\_\_.

A. by      B. on      C. from      D. but      E. to      F. up

A) ADC    B) BDC    C) DBF    D) CDB    E) ADB

**DIRECTIONS for the question:** The questions below have three sentences, with each sentence having one blank. Beneath the sentence are six lettered words which are labeled A, B, C, D, E and F. Out of these words, three would fit the blanks given. You are to choose the sequence of words that best fits the three sentences (the first word of the sequence is for the first sentence, the second word of the sequence is for the second sentence and the third word of the sequence is for the third sentence).

**Question No. : 22**

- (I) Stalled power projects in the country could be recharged with the government's action plan to increase generating capacity \_\_\_ asking banks to help revive such projects and by providing fuel linkages.
- (II) Power minister Piyush Goyal today met oil minister Dharmendra Pradhan to chalk \_\_\_ the rescue package that may involve rescheduling of loans to power companies as well as making available fuel at affordable prices by pooling cheaper domestic gas price with costly imported LNG.
- (III) The two ministers did not divulge details \_\_\_ the rescue package finalised today which may need the cabinet's approval.

A. through      B. of      C. as      D. in      E. by      F. out

A) BDF    B) ADB    C) EFB    D) EFD    E) EAD

**Question No. : 23**

**DIRECTIONS for the question:** Read the following passage and answer the question based on it.

Enterprises in the throes of discovery have an aura of magic around them. In the world of software this becomes many-splendoured with a certain *joie de vivre* quite distinct from what obtains elsewhere: a sense of wonderment, surprise and eventual delight; a coming within reach of power and profits; possibly through a *little tweak* in technology with a touch of novelty, opening up vistas that had always seemed so near yet so far. In professional management terms, this waving of the wizard's wand, as it were, is nothings more than an effective recovery of strategy from a technological paradigm. This book is about exploring the journey from rules and norms to solutions, specific solutions prised out of the armoured covers of sector-specific industrial structures and often resources-determined mindsets that Indian software firms seem to have mastered. Originality is the fountainhead of such a strategy. It then progresses into the realms of the economics of innovation to give itself a solid foundation from where it becomes possible to retrieve a new language of strategy and of innovation. In this highly natural yet dynamic world, the profit motive, backed by ingenuity, lends support to many of the arguments that evolve in this flow of events. The Indian software experience is a unique demonstration of how this process - the coalescing of the economics of surprise and novelty and the economics of knowledge - works. This forms the basics of the strategy theory.

There are several grand theories of even grander traditions: the industrial organization approach, including several kinds of structure-conduct-performance assertions and game theoretic models, evolutionary theories and corresponding case studies, resource-based approaches or several intermediate variants of competency-based ideas that provide us with a rich yet incomplete landscape. This landscape is perhaps oblivious of certain traditions provided by theory; the rich repertoire bequeathed by Marshall and Shackle is a case in point, as they are immensely rewarding. Each important tradition or theory has made global assertions and has proved to be prescriptive or normative. Some authors have looked back at Marshall and a handful at Shackle. Fewer still reconsidered certain rich traditions of thinking on strategy. This book does not attempt to issue prescriptive or normative guidelines purely because the global canvas is too large and often beyond the capacity of intelligent comprehension. A strategist acts on a local scale following what Simon has generally observed. Pragmatism emerges as an important guide and achieving the surprise element is above all, the key to definitive strategy. While this strategy *evolves from governance*, it also influences governance at every stage. Handicapped by a paucity of resources, the strategist must dovetail the two to increase immensely the scope of governance not only over what the incumbent possesses, but also over a much larger group of firms not under its direct control. This need not necessarily be explained by another grand theory with globally prescriptive assertions or powers of predictions. Surprise must stand beyond predictability. It must govern to earn windfall profit. Strategy thus cannot be prescribed; it would comprise piecemeal engineering. This is what this book explains.

The locale of the phrase "acting on a local scale" as used in the passage above refers to:

- A) Cognitively delimited space    B) Geographically delimited space    C) Temporally delimited space  
D) Economically delimited space    E) None of the above

**Question No. : 24**

**DIRECTIONS for the question:** Read the following passage and answer the question based on it.

Enterprises in the throes of discovery have an aura of magic around them. In the world of software this becomes many-splendoured with a certain *joie de vivre* quite distinct from what obtains elsewhere: a sense of wonderment, surprise and eventual delight; a coming within reach of power and profits; possibly through a *little tweak* in technology with a touch of novelty, opening up vistas that had always seemed so near yet so far. In professional management terms, this waving of the wizard's wand, as it were, is nothings more than an effective recovery of strategy from a technological paradigm. This book is about exploring the journey from rules and norms to solutions, specific solutions prised out of the armoured covers of sector-specific industrial structures and often resources-determined mindsets that Indian software firms seem to have mastered. Originality is the fountainhead of such a strategy. It then progresses into the realms of the economics of innovation to give itself a solid foundation from where it becomes possible to retrieve a new language of strategy and of innovation. In this highly natural yet dynamic world, the profit motive, backed by ingenuity, lends support to many of the arguments that evolve in this flow of events. The Indian software experience is a unique demonstration of how this process - the coalescing of the economics of surprise and novelty and the economics of knowledge - works. This forms the basics of the strategy theory.

There are several grand theories of even grander traditions: the industrial organization approach, including several kinds of structure-conduct-performance assertions and game theoretic models, evolutionary theories and corresponding case studies, resource-based approaches or several intermediate variants of competency-based ideas that provide us with a rich yet incomplete landscape. This landscape is perhaps oblivious of certain traditions provided by theory; the rich repertoire bequeathed by Marshall and Shackle is a case in point, as they are immensely rewarding. Each important tradition or theory has made global assertions and has proved to be prescriptive or normative. Some authors have looked back at Marshall and a handful at Shackle. Fewer still reconsidered certain rich traditions of thinking on strategy. This book does not attempt to issue prescriptive or normative guidelines purely because the global canvas is too large and often beyond the capacity of intelligent comprehension. A strategist acts on a local scale following what Simon has generally observed. Pragmatism emerges as an important guide and achieving the surprise element is above all, the key to definitive strategy. While this strategy *evolves from governance*, it also influences governance at every stage. Handicapped by a paucity of resources, the strategist must dovetail the two to increase immensely the scope of governance not only over what the incumbent possesses, but also over a much larger group of firms not under its direct control. This need not necessarily be explained by another grand theory with globally prescriptive assertions or powers of predictions. Surprise must stand beyond predictability. It must govern to earn windfall profit. Strategy thus cannot be prescribed; it would comprise piecemeal engineering. This is what this book explains.

The idea of a 'magic' as used in the passage refers to:

- A) Irrationality and blind belief    B) A sense of wonder at imagination unbridled by any governance whatsoever  
C) A sense of wonder at the discovery of a grand theory    D) A coming within reach of power and profits  
E) None of the above

**Question No. : 25**

**DIRECTIONS for the question:** Read the following passage and answer the question based on it.

Enterprises in the throes of discovery have an aura of magic around them. In the world of software this becomes many-splendoured with a certain *joie de vivre* quite distinct from what obtains elsewhere: a sense of wonderment, surprise and eventual delight; a coming within reach of power and profits; possibly through a *little tweak* in technology with a touch of novelty, opening up vistas that had always seemed so near yet so far. In professional management terms, this waving of the wizard's wand, as it were, is nothings more than an effective recovery of strategy from a technological paradigm. This book is about exploring the journey from rules and norms to solutions, specific solutions prised out of the armoured covers of sector-specific industrial structures and often resources-determined mindsets that Indian software firms seem to have mastered. Originality is the fountainhead of such a strategy. It then progresses into the realms of the economics of innovation to give itself a solid foundation from where it becomes possible to retrieve a new language of strategy and of innovation. In this highly natural yet dynamic world, the profit motive, backed by ingenuity, lends support to many of the arguments that evolve in this flow of events. The Indian software experience is a unique demonstration of how this process - the coalescing of the economics of surprise and novelty and the economics of knowledge - works. This forms the basics of the strategy theory.

There are several grand theories of even grander traditions: the industrial organization approach, including several kinds of structure-conduct-performance assertions and game theoretic models, evolutionary theories and corresponding case studies, resource-based approaches or several intermediate variants of competency-based ideas that provide us with a rich yet incomplete landscape. This landscape is perhaps oblivious of certain traditions provided by theory; the rich repertoire bequeathed by Marshall and Shackle is a case in point, as they are immensely rewarding. Each important tradition or theory has made global assertions and has proved to be prescriptive or normative. Some authors have looked back at Marshall and a handful at Shackle. Fewer still reconsidered certain rich traditions of thinking on strategy. This book does not attempt to issue prescriptive or normative guidelines purely because the global canvas is too large and often beyond the capacity of intelligent comprehension. A strategist acts on a local scale following what Simon has generally observed. Pragmatism emerges as an important guide and achieving the surprise element is above all, the key to definitive strategy. While this strategy *evolves from governance*, it also influences governance at every stage. Handicapped by a paucity of resources, the strategist must dovetail the two to increase immensely the scope of governance not only over what the incumbent possesses, but also over a much larger group of firms not under its direct control. This need not necessarily be explained by another grand theory with globally prescriptive assertions or powers of predictions. Surprise must stand beyond predictability. It must govern to earn windfall profit. Strategy thus cannot be prescribed; it would comprise piecemeal engineering. This is what this book explains.

According to the author, the several extant strands of strategy literature such as the Industrial Organization approach provide an incomplete landscape because:

- A) They fail to take account of contributions of Marshall and Shackle    B) It is normative in nature  
C) The vastly rich and unfolding reality is beyond the capacity of human comprehension    D) It is prescriptive in nature  
E) None of the above

**Question No. : 26**

**DIRECTIONS for the question:** Read the following passage and answer the question based on it.

Enterprises in the throes of discovery have an aura of magic around them. In the world of software this becomes many-splendoured with a certain *joie de vivre* quite distinct from what obtains elsewhere: a sense of wonderment, surprise and eventual delight; a coming within reach of power and profits; possibly through a *little tweak* in technology with a touch of novelty, opening up vistas that had always seemed so near yet so far. In professional management terms, this waving of the wizard's wand, as it were, is nothings more than an effective recovery of strategy from a technological paradigm. This book is about exploring the journey from rules and norms to solutions, specific solutions prised out of the armoured covers of sector-specific industrial structures and often resources-determined mindsets that Indian software firms seem to have mastered. Originality is the fountainhead of such a strategy. It then progresses into the realms of the economics of innovation to give itself a solid foundation from where it becomes possible to retrieve a new language of strategy and of innovation. In this highly natural yet dynamic world, the profit motive, backed by ingenuity, lends support to many of the arguments that evolve in this flow of events. The Indian software experience is a unique demonstration of how this process - the coalescing of the economics of surprise and novelty and the economics of knowledge - works. This forms the basics of the strategy theory.

There are several grand theories of even grander traditions: the industrial organization approach, including several kinds of structure-conduct-performance assertions and game theoretic models, evolutionary theories and corresponding case studies, resource-based approaches or several intermediate variants of competency-based ideas that provide us with a rich yet incomplete landscape. This landscape is perhaps oblivious of certain traditions provided by theory; the rich repertoire bequeathed by Marshall and Shackle is a case in point, as they are immensely rewarding. Each important tradition or theory has made global assertions and has proved to be prescriptive or normative. Some authors have looked back at Marshall and a handful at Shackle. Fewer still reconsidered certain rich traditions of thinking on strategy. This book does not attempt to issue prescriptive or normative guidelines purely because the global canvas is too large and often beyond the capacity of intelligent comprehension. A strategist acts on a local scale following what Simon has generally observed. Pragmatism emerges as an important guide and achieving the surprise element is above all, the key to definitive strategy. While this strategy *evolves from governance*, it also influences governance at every stage. Handicapped by a paucity of resources, the strategist must dovetail the two to increase immensely the scope of governance not only over what the incumbent possesses, but also over a much larger group of firms not under its direct control. This need not necessarily be explained by another grand theory with globally prescriptive assertions or powers of predictions. Surprise must stand beyond predictability. It must govern to earn windfall profit. Strategy thus cannot be prescribed; it would comprise piecemeal engineering. This is what this book explains.

Which of the following follows from the passage?

- A) Indian software firms have excelled in providing specific solutions
- B) Indian software firms have been remarkable technology innovators
- C) Indian software firms have benefited from low priced manpower with adequate programming skills
- D) Indian software firms have a great reputation in the world
- E) None of the above

**DIRECTIONS for the question :** Read the passage and answer the question based on it.

**Question No. : 27**

During the 1940s and 1950s the United States government developed a new policy toward Native Americans, often known as "readjustment." Because the increased awareness of civil rights in these 5 decades helped reinforce the belief that life on reservations prevented Native Americans from exercising the rights guaranteed to citizens "under the United States Constitution, the readjustment movement advocated the end of the federal government's involvement in Native American affairs and encouraged the assimilation of Native Americans as individuals into mainstream society. However, the same years also saw the emergence of a Native American leadership and efforts to develop tribal institutions and reaffirm tribal identity.

The clash of these two trends may be traced in the attempts on the part of the Bureau of Indian Affairs (BIA) to convince the Oneida tribe of Wisconsin to accept readjustment. The culmination of BIA efforts to sway the Oneida occurred at a meeting that took place in the fall of 1956. The BIA suggested that it would be to the Oneida's benefit to own their own property and, like other homeowners, pay real estate taxes on it. The BIA also emphasized that, after readjustment, the government would not attempt to restrict Native Americans' ability to sell their individually owned lands. The Oneida were then offered a one-time lump-sum payment of \$60,000 in lieu of the \$0.52 annuity guaranteed in perpetuity to each member of the tribe under the Canandaigua Treaty. The efforts of the BIA to "sell" readjustment to the tribe failed because the Oneida realized that they had heard similar offers before.

The Oneida delegates reacted negatively to the BIA's first suggestion because taxation of Native American lands had been one past vehicle for dispossessing the Oneida: after the distribution of some tribal lands to individual Native Americans in the late nineteenth century, Native American lands became subject to taxation, resulting in new and impossible financial burdens, foreclosures, and subsequent tax sales of property. The Oneida delegates were equally suspicious of the BIA's emphasis on the rights of individual landowners, since in the late nineteenth century many individual Native Americans had been convinced by unscrupulous speculators to sell their lands. Finally, the offer of a lump-sum payment was unanimously opposed by the Oneida delegates, who saw that changing the terms of a treaty might jeopardize the many pending land claims based upon the treaty. As a result of the 1956 meeting, the Oneida rejected readjustment. Instead, they determined to improve tribal life by lobbying for federal monies for postsecondary education, for the improvement of drainage on tribal lands, and for the building of a convalescent home for tribal members. Thus, by learning the lessons of history, the Oneida were able to survive as a tribe in their homeland.

Which one of the following would be most consistent with the policy of readjustment described in the passage?

- A) the establishment among Native Americans of a tribal system of elected government
- B) the creation of a national project to preserve Native American language and oral history
- C) the establishment of programs to encourage Native Americans to move from reservations to urban areas
- D) the development of a large-scale effort to restore Native American lands to their original tribes
- E) the reaffirmation of federal treaty obligations to Native American tribes

**DIRECTIONS for the question :** Read the passage and answer the question based on it.

**Question No. : 28**

During the 1940s and 1950s the United States government developed a new policy toward Native Americans, often known as "readjustment." Because the increased awareness of civil rights in these 5 decades helped reinforce the belief that life on reservations prevented Native Americans from exercising the rights guaranteed to citizens "under the United States Constitution, the readjustment movement advocated the end of the federal government's involvement in Native American affairs and encouraged the assimilation of Native Americans as individuals into mainstream society. However, the same years also saw the emergence of a Native American leadership and efforts to develop tribal institutions and reaffirm tribal identity.

The clash of these two trends may be traced in the attempts on the part of the Bureau of Indian Affairs (BIA) to convince the Oneida tribe of Wisconsin to accept readjustment. The culmination of BIA efforts to sway the Oneida occurred at a meeting that took place in the fall of 1956. The BIA suggested that it would be to the Oneida's benefit to own their own property and, like other homeowners, pay real estate taxes on it. The BIA also emphasized that, after readjustment, the government would not attempt to restrict Native Americans' ability to sell their individually owned lands. The Oneida were then offered a one-time lump-sum payment of \$60,000 in lieu of the \$0.52 annuity guaranteed in perpetuity to each member of the tribe under the Canandaigua Treaty. The efforts of the BIA to "sell" readjustment to the tribe failed because the Oneida realized that they had heard similar offers before.

The Oneida delegates reacted negatively to the BIA's first suggestion because taxation of Native American lands had been one past vehicle for dispossessing the Oneida: after the distribution of some tribal lands to individual Native Americans in the late nineteenth century, Native American lands became subject to taxation, resulting in new and impossible financial burdens, foreclosures, and subsequent tax sales of property. The Oneida delegates were equally suspicious of the BIA's emphasis on the rights of individual landowners, since in the late nineteenth century many individual Native Americans had been convinced by unscrupulous speculators to sell their lands. Finally, the offer of a lump-sum payment was unanimously opposed by the Oneida delegates, who saw that changing the terms of a treaty might jeopardize the many pending land claims based upon the treaty. As a result of the 1956 meeting, the Oneida rejected readjustment. Instead, they determined to improve tribal life by lobbying for federal monies for postsecondary education, for the improvement of drainage on tribal lands, and for the building of a convalescent home for tribal members. Thus, by learning the lessons of history, the Oneida were able to survive as a tribe in their homeland.

According to the passage, after the 1956 meeting the Oneida resolved to

- A) obtain improved social services and living conditions for members of the tribe
- B) pursue litigation designed to reclaim tribal lands
- C) secure recognition of their unique status as a self-governing Native American nation within the United States
- D) establish new kinds of tribal institutions
- E) cultivate a life-style similar to that of other United States citizens

**DIRECTIONS for the question :** Read the passage and answer the question based on it.

**Question No. : 29**

During the 1940s and 1950s the United States government developed a new policy toward Native Americans, often known as "readjustment." Because the increased awareness of civil rights in these 5 decades helped reinforce the belief that life on reservations prevented Native Americans from exercising the rights guaranteed to citizens "under the United States Constitution, the readjustment movement advocated the end of the federal government's involvement in Native American affairs and encouraged the assimilation of Native Americans as individuals into mainstream society. However, the same years also saw the emergence of a Native American leadership and efforts to develop tribal institutions and reaffirm tribal identity.

The clash of these two trends may be traced in the attempts on the part of the Bureau of Indian Affairs (BIA) to convince the Oneida tribe of Wisconsin to accept readjustment. The culmination of BIA efforts to sway the Oneida occurred at a meeting that took place in the fall of 1956. The BIA suggested that it would be to the Oneida's benefit to own their own property and, like other homeowners, pay real estate taxes on it. The BIA also emphasized that, after readjustment, the government would not attempt to restrict Native Americans' ability to sell their individually owned lands. The Oneida were then offered a one-time lump-sum payment of \$60,000 in lieu of the \$0.52 annuity guaranteed in perpetuity to each member of the tribe under the Canandaigua Treaty. The efforts of the BIA to "sell" readjustment to the tribe failed because the Oneida realized that they had heard similar offers before.

The Oneida delegates reacted negatively to the BIA's first suggestion because taxation of Native American lands had been one past vehicle for dispossessing the Oneida: after the distribution of some tribal lands to individual Native Americans in the late nineteenth century, Native American lands became subject to taxation, resulting in new and impossible financial burdens, foreclosures, and subsequent tax sales of property. The Oneida delegates were equally suspicious of the BIA's emphasis on the rights of individual landowners, since in the late nineteenth century many individual Native Americans had been convinced by unscrupulous speculators to sell their lands. Finally, the offer of a lump-sum payment was unanimously opposed by the Oneida delegates, who saw that changing the terms of a treaty might jeopardize the many pending land claims based upon the treaty. As a result of the 1956 meeting, the Oneida rejected readjustment. Instead, they determined to improve tribal life by lobbying for federal monies for postsecondary education, for the improvement of drainage on tribal lands, and for the building of a convalescent home for tribal members. Thus, by learning the lessons of history, the Oneida were able to survive as a tribe in their homeland.

Which one of the following best describes the function of the first paragraph in the context of the passage as a whole?

- A) It summarizes the basis of a conflict underlying negotiations described elsewhere in the passage
- B) It presents two positions, one of which is defended by evidence provided in succeeding paragraphs
- C) It compares competing interpretations of a historical conflict
- D) It analyzes the causes of a specific historical event and predicts a future development
- E) It outlines the history of a government agency

**DIRECTIONS for the question :** Read the passage and answer the question based on it.

**Question No. : 30**

During the 1940s and 1950s the United States government developed a new policy toward Native Americans, often known as "readjustment." Because the increased awareness of civil rights in these 5 decades helped reinforce the belief that life on reservations prevented Native Americans from exercising the rights guaranteed to citizens "under the United States Constitution, the readjustment movement advocated the end of the federal government's involvement in Native American affairs and encouraged the assimilation of Native Americans as individuals into mainstream society. However, the same years also saw the emergence of a Native American leadership and efforts to develop tribal institutions and reaffirm tribal identity.

The clash of these two trends may be traced in the attempts on the part of the Bureau of Indian Affairs (BIA) to convince the Oneida tribe of Wisconsin to accept readjustment. The culmination of BIA efforts to sway the Oneida occurred at a meeting that took place in the fall of 1956. The BIA suggested that it would be to the Oneida's benefit to own their own property and, like other homeowners, pay real estate taxes on it. The BIA also emphasized that, after readjustment, the government would not attempt to restrict Native Americans' ability to sell their individually owned lands. The Oneida were then offered a one-time lump-sum payment of \$60,000 in lieu of the \$0.52 annuity guaranteed in perpetuity to each member of the tribe under the Canandaigua Treaty. The efforts of the BIA to "sell" readjustment to the tribe failed because the Oneida realized that they had heard similar offers before.

The Oneida delegates reacted negatively to the BIA's first suggestion because taxation of Native American lands had been one past vehicle for dispossessing the Oneida: after the distribution of some tribal lands to individual Native Americans in the late nineteenth century, Native American lands became subject to taxation, resulting in new and impossible financial burdens, foreclosures, and subsequent tax sales of property. The Oneida delegates were equally suspicious of the BIA's emphasis on the rights of individual landowners, since in the late nineteenth century many individual Native Americans had been convinced by unscrupulous speculators to sell their lands. Finally, the offer of a lump-sum payment was unanimously opposed by the Oneida delegates, who saw that changing the terms of a treaty might jeopardize the many pending land claims based upon the treaty. As a result of the 1956 meeting, the Oneida rejected readjustment. Instead, they determined to improve tribal life by lobbying for federal monies for postsecondary education, for the improvement of drainage on tribal lands, and for the building of a convalescent home for tribal members. Thus, by learning the lessons of history, the Oneida were able to survive as a tribe in their homeland.

Which one of the following best describes the function of the first paragraph in the context of the passage as a whole?

- A) It summarizes the basis of a conflict underlying negotiations described elsewhere in the passage
- B) It presents two positions, one of which is defended by evidence provided in succeeding paragraphs
- C) It compares competing interpretations of a historical conflict
- D) It analyzes the causes of a specific historical event and predicts a future development
- E) It outlines the history of a government agency

**DIRECTIONS for the question:** The questions below have three sentences, with each sentence having one blank. Beneath the sentence are six lettered words which are labeled A, B, C, D, E and F. Out of these words, three would fit the blanks given. You are to choose the sequence of words that best fits the three sentences (the first word of the sequence is for the first sentence, the second word of the sequence is for the second sentence and the third word of the sequence is for the third sentence).

**Question No. : 31**

- (I) The naming of cats, according \_\_\_ a famous poet, is a difficult matter: "It isn't just one of your holiday games."
- (II) Most eminent politicians in India would agree \_\_\_ the seriousness of such matters — except that 'cats', in their case, would have to be substituted by public institutions, facilities and welfare schemes.
- (III) Naming a new university, hospital, flyover or rural yojana is much more \_\_\_ what the usual business of civic commemoration might suggest in a modern democracy.

A. for      B. than      C. to      D. where      E. by      F. with

A) CAD    B) CAE    C) DCA    D) CFB    E) CAF

**DIRECTIONS for the question:** The questions below have three sentences, with each sentence having one blank. Beneath the sentence are six lettered words which are labeled A, B, C, D, E and F. Out of these words, three would fit the blanks given. You are to choose the sequence of words that best fits the three sentences (the first word of the sequence is for the first sentence, the second word of the sequence is for the second sentence and the third word of the sequence is for the third sentence).

**Question No. : 32**

(I) The once-dominant international cartel of oil producers is losing \_\_\_ sway over the global energy markets as oil prices continue to plummet.

(II) At its meeting tomorrow in Vienna, the Organisation of the Petroleum Exporting Countries, the group of 12 oil producing nations, is under pressure to at least announce modest cuts in an effort to shore\_\_\_ the markets.

(III) But any cuts would be modest and would probably do little to prop up oil prices, assuming the countries \_\_\_ stick to an agreement.

A. its      B. their      C. in      D. up      E. even      F. may

A) BDE    B) ADE    C) ACE    D) BCF    E) BDF

CAREERS360

**DIRECTIONS for the question :** Read the passage and answer the question based on it.

**Question No. : 33**

Personal names are generally regarded by European thinkers in two major ways, both of which deny that names have any significant semantic content. In philosophy and linguistics, John Stuart Mill's formulation that "proper names are meaningless marks set upon...persons to distinguish them from one another" retains currency; in anthropology, Claude Levi-Strauss's characterization of names as being primarily instruments of social classification has been very influential. Consequently, interpretation of personal names in societies where names have other functions and meanings has been neglected. Among the Hopi of the southwestern United States, names often refer to historical or ritual events in order both to place individuals within society and to confer an identity upon them. Furthermore, the images used to evoke these events suggest that Hopi names can be seen as a type of poetic composition.

Throughout life, Hopi's received several names in a sequence of ritual initiations. Birth, entry into one of the ritual societies during childhood, and puberty are among the name giving occasions. Names are conferred by an adult member of a clan other than the child's clan, and names refer to that name givers clan, sometimes combining characteristics of the clan's totem animal with the child's characteristics. Thus, a name might translate to something as simple as "little rabbit," which reflects both the child's size and the representative animal.

More often, though, the name giver has in mind a specific event that is not apparent in a name's literal translation. One Lizard clan member from the village of Oraibi is named Lomayayva, "beautifully ascended." This translation, however, tells nothing about either the event referred to-who or what ascended-or the name givers clan. The name giver in this case is from Badger clan. Badger clan is responsible for an annual ceremony featuring a procession in which masked representations of spirits climb the mesa on which Oraibi sits. Combining the name giver's clan association with the receiver's home village, "beautifully ascended" refers to the splendid colors and movements of the procession up the mesa. The condensed image this name evokes-a typical feature of Hopi personal names-displays the same quality of Western Apache place names that led one commentator to call them "tiny imagist poems."

Hopi personal names do several things simultaneously. They indicate social relationships-but only indirectly-and they individuate persons. Equally important, though, is their poetic quality; in a sense they can be understood as oral texts that produce aesthetic delight. This view of Hopi names is thus opposed not only to Mill's claim that personal names are without inherent meaning but also to Levi-Strauss's purely functional characterization. Interpreters must understand Hopi clan structures and linguistic practices in order to discern the beauty and significance of Hopi names."

Which of the following most accurately summarizes the passages' main point?

- A) Unlike European names, which are used exclusively for identification or exclusively for social classification, Hopi names perform both these functions simultaneously
- B) Unlike European names, Hopi names tend to neglect the functions of identification and social classification in favor of a concentration on compression and poetic effects
- C) Lacking knowledge of the intricacies of Hopi linguistic and tribal structures, European thinkers have so far been unable to discern the deeper significance of Hopi names
- D) Although some Hopi names may seem difficult to interpret, they all conform to a formula whereby a reference to the name giver's clan is combined with a reference to the person named
- E) While performing the functions ascribed to names by European thinkers, Hopi names also possess a significant aesthetic quality that these thinkers have not adequately recognized

**DIRECTIONS for the question :** Read the passage and answer the question based on it.

**Question No. : 34**

Personal names are generally regarded by European thinkers in two major ways, both of which deny that names have any significant semantic content. In philosophy and linguistics, John Stuart Mill's formulation that "proper names are meaningless marks set upon...persons to distinguish them from one another" retains currency; in anthropology, Claude Levi-Strauss's characterization of names as being primarily instruments of social classification has been very influential. Consequently, interpretation of personal names in societies where names have other functions and meanings has been neglected. Among the Hopi of the southwestern United States, names often refer to historical or ritual events in order both to place individuals within society and to confer an identity upon them. Furthermore, the images used to evoke these events suggest that Hopi names can be seen as a type of poetic composition.

Throughout life, Hopi's received several names in a sequence of ritual initiations. Birth, entry into one of the ritual societies during childhood, and puberty are among the name giving occasions. Names are conferred by an adult member of a clan other than the child's clan, and names refer to that name givers clan, sometimes combining characteristics of the clan's totem animal with the child's characteristics. Thus, a name might translate to something as simple as "little rabbit," which reflects both the child's size and the representative animal.

More often, though, the name giver has in mind a specific event that is not apparent in a name's literal translation. One Lizard clan member from the village of Oraibi is named Lomayayva, "beautifully ascended." This translation, however, tells nothing about either the event referred to-who or what ascended-or the name givers clan. The name giver in this case is from Badger clan. Badger clan is responsible for an annual ceremony featuring a procession in which masked representations of spirits climb the mesa on which Oraibi sits. Combining the name giver's clan association with the receiver's home village, "beautifully ascended" refers to the splendid colors and movements of the procession up the mesa. The condensed image this name evokes-a typical feature of Hopi personal names-displays the same quality of Western Apache place names that led one commentator to call them "tiny imagist poems."

Hopi personal names do several things simultaneously. They indicate social relationships-but only indirectly-and they individuate persons. Equally important, though, is their poetic quality; in a sense they can be understood as oral texts that produce aesthetic delight. This view of Hopi names is thus opposed not only to Mill's claim that personal names are without inherent meaning but also to Levi-Strauss's purely functional characterization. Interpreters must understand Hopi clan structures and linguistic practices in order to discern the beauty and significance of Hopi names."

The author most likely refers to Western Apache place names in order to?

- A) offer an example of how names can contain references not evident in their literal translations
- B) apply a commentator's characterization of Western Apache naming practices to Hopi personal names
- C) contrast Western Apache naming practices with Hopi naming practices
- D) demonstrate that other names besides Hopi names may have some semantic content
- E) explain how a specific Hopi name refers subtly to a particular Western Apache site

**DIRECTIONS for the question :** Read the passage and answer the question based on it.

**Question No. : 35**

Personal names are generally regarded by European thinkers in two major ways, both of which deny that names have any significant semantic content. In philosophy and linguistics, John Stuart Mill's formulation that "proper names are meaningless marks set upon...persons to distinguish them from one another" retains currency; in anthropology, Claude Levi-Strauss's characterization of names as being primarily instruments of social classification has been very influential. Consequently, interpretation of personal names in societies where names have other functions and meanings has been neglected. Among the Hopi of the southwestern United States, names often refer to historical or ritual events in order both to place individuals within society and to confer an identity upon them. Furthermore, the images used to evoke these events suggest that Hopi names can be seen as a type of poetic composition.

Throughout life, Hopi's received several names in a sequence of ritual initiations. Birth, entry into one of the ritual societies during childhood, and puberty are among the name giving occasions. Names are conferred by an adult member of a clan other than the child's clan, and names refer to that name givers clan, sometimes combining characteristics of the clan's totem animal with the child's characteristics. Thus, a name might translate to something as simple as "little rabbit," which reflects both the child's size and the representative animal.

More often, though, the name giver has in mind a specific event that is not apparent in a name's literal translation. One Lizard clan member from the village of Oraibi is named Lomayayva, "beautifully ascended." This translation, however, tells nothing about either the event referred to-who or what ascended-or the name givers clan. The name giver in this case is from Badger clan. Badger clan is responsible for an annual ceremony featuring a procession in which masked representations of spirits climb the mesa on which Oraibi sits. Combining the name giver's clan association with the receiver's home village, "beautifully ascended" refers to the splendid colors and movements of the procession up the mesa. The condensed image this name evokes-a typical feature of Hopi personal names-displays the same quality of Western Apache place names that led one commentator to call them "tiny imagist poems."

Hopi personal names do several things simultaneously. They indicate social relationships-but only indirectly-and they individuate persons. Equally important, though, is their poetic quality; in a sense they can be understood as oral texts that produce aesthetic delight. This view of Hopi names is thus opposed not only to Mill's claim that personal names are without inherent meaning but also to Levi-Strauss's purely functional characterization. Interpreters must understand Hopi clan structures and linguistic practices in order to discern the beauty and significance of Hopi names."

Which one of the following statements describes an example of the function accorded to personal names under Levi-Strauss's view?

- A) Some parents select their children's names from impersonal sources such as books.
- B) Some parents wait to give a child a name in order to choose one that reflects the child's looks or personality
- C) Some parents name their children in honor of friends or famous people
- D) Some family members have no parts of their names in common
- E) Some family names originated as identifications of their bearer's social status

**DIRECTIONS for the question :** Read the passage and answer the question based on it.

**Question No. : 36**

Personal names are generally regarded by European thinkers in two major ways, both of which deny that names have any significant semantic content. In philosophy and linguistics, John Stuart Mill's formulation that "proper names are meaningless marks set upon...persons to distinguish them from one another" retains currency; in anthropology, Claude Levi-Strauss's characterization of names as being primarily instruments of social classification has been very influential. Consequently, interpretation of personal names in societies where names have other functions and meanings has been neglected. Among the Hopi of the southwestern United States, names often refer to historical or ritual events in order both to place individuals within society and to confer an identity upon them. Furthermore, the images used to evoke these events suggest that Hopi names can be seen as a type of poetic composition.

Throughout life, Hopi's received several names in a sequence of ritual initiations. Birth, entry into one of the ritual societies during childhood, and puberty are among the name giving occasions. Names are conferred by an adult member of a clan other than the child's clan, and names refer to that name givers clan, sometimes combining characteristics of the clan's totem animal with the child's characteristics. Thus, a name might translate to something as simple as "little rabbit," which reflects both the child's size and the representative animal.

More often, though, the name giver has in mind a specific event that is not apparent in a name's literal translation. One Lizard clan member from the village of Oraibi is named Lomayayva, "beautifully ascended." This translation, however, tells nothing about either the event referred to-who or what ascended-or the name givers clan. The name giver in this case is from Badger clan. Badger clan is responsible for an annual ceremony featuring a procession in which masked representations of spirits climb the mesa on which Oraibi sits. Combining the name giver's clan association with the receiver's home village, "beautifully ascended" refers to the splendid colors and movements of the procession up the mesa. The condensed image this name evokes-a typical feature of Hopi personal names-displays the same quality of Western Apache place names that led one commentator to call them "tiny imagist poems."

Hopi personal names do several things simultaneously. They indicate social relationships-but only indirectly-and they individuate persons. Equally important, though, is their poetic quality; in a sense they can be understood as oral texts that produce aesthetic delight. This view of Hopi names is thus opposed not only to Mill's claim that personal names are without inherent meaning but also to Levi-Strauss's purely functional characterization. Interpreters must understand Hopi clan structures and linguistic practices in order to discern the beauty and significance of Hopi names."

The primary function of the second paragraph is to

- A) present reasons why Hopi personal names can be treated as poetic compositions
- B) support the claim that Hopi personal names make reference to events in the recipient's life
- C) argue that the fact that Hopis receive many names throughout life refutes European theories about naming
- D) illustrate ways in which Hopi personal names may have semantic content
- E) demonstrate that the literal translation of Hopi personal names often obscures their true meaning

---

**Section : Quantitative Ability**

**DIRECTIONS for the question:** Solve the following question and mark the best possible option.

**Question No. : 37**

The angles of a quadrilateral are in the ratio of 2 : 4 : 7 : 5. The smallest angle of the quadrilateral is equal to the smallest angle of a triangle. One of the angles of the triangle is twice the smallest angle of the triangle. What is the second largest angle of the triangle ?

- A) 80°
- B) 60°
- C) 120°
- D) Cannot be determined
- E) None of these

**DIRECTION for the question:** Solve the following question and mark the best possible option.

**Question No. : 38**

A shopkeeper sells notebooks at the rate of Rs. 45/- each and earns a commission of 4%. He also sells pencil box at the rate of Rs. 80/- each and earns a commission of 20%. How much amount of commission will he earn in two weeks if he sells 10 notebooks and 6 pencil boxes a day ?

- A) Rs. 1,956/-   B) Rs. 1,586/-   C) Rs. 1,496/-   D) Rs. 1,596/-   E) None of these

**DIRECTION for the question:** Solve the following question and mark the best possible option.

**Question No. : 39**

In a printer factory there are 3 machines A1, A2 and A3 which produces 35%, 30% and 35% of the total printers respectively. If A1, A2 and A3 produces 2%, 4% and 3% of defective printers. What is the percentage of non-defective printers approximately?

- A) 88%   B) 99%   C) 90%   D) 95%   E) 97%

**DIRECTIONS for the question:** Solve the following question and mark the best possible option.

**Question No. : 40**

8 men can complete a piece of work in 20 days. 8 women can complete the same work in 32 days. In how many days will 5 men and 8 women together complete the same work ?

- A) 16 days   B) 12 days   C) 14 days   D) 10 days   E) None of these

**DIRECTIONS for the question:** Solve the following question and mark the best possible option.

**Question No. : 41**

The area of a square is 1024 sq. cms. What is the respective ratio between the length and the breadth of a rectangle whose length is twice the side of the square and breadth is 12 cms. less than the side of the square ?

- A) 5 : 18   B) 16 : 7   C) 14 : 5   D) 32 : 5   E) None of these

**DIRECTIONS for the question:** Solve the following question and mark the best possible option.

**Question No. : 42**

The sum of five consecutive even numbers of set-A is 220. What is the sum of a different set of five consecutive numbers whose second lowest number is 37 less than double of the lowest number of set-A ?

- A) 223   B) 225   C) 235   D) 243   E) None of these

**DIRECTIONS for the question:** Solve the following question and mark the best possible option.

**Question No. : 43**

The bus fare for one person is Rs. 420/- from Agra to Aligarh and train fare between the same places for one person is equal to three-fourth the bus fare for two persons between the same places. What is the total fare paid by 2 persons travelling by bus and 4 persons travelling by train between the two places ?

- A) Rs. 3,360/-   B) Rs. 3,460/-   C) Rs. 3,440/-   D) Rs. 3,406/-   E) None of these

**DIRECTIONS for the question:** Solve the following question and mark the best possible option.

**Question No. : 44**

The respective ratio between the speeds of a car, a jeep and a tractor is 3 : 5 : 2. The speed of the jeep is 250 percent the speed of the tractor which covers 360 kms in 12 hours. What is the average speed of car and jeep together ?

- A) 60 km/hr.   B) 75 km/hr.   C) 40 km/hr.   D) Cannot be determined   E) None of these

**DIRECTIONS for the question:** Mark the best option.

**Question No. : 45**

There was one mess for 30 boarders in a certain hostel. If the number of boarders was increased by 10, the expenses of the mess increased by Rs. 40 per month, while the average expenditure per head diminished by Rs. 2. Find the original monthly expenses.

- A) Rs. 390   B) Rs. 360   C) Rs. 410   D) Rs. 480   E) None of these

**DIRECTIONS for the question:** Mark the best option.

**Question No. : 46**

Two men A and B working together complete a piece of work which it would have taken them 30 and 40 days respectively to complete if they worked separately. If they received a payment of Rs. 2,100. B's share is :

- A) Rs. 900   B) Rs. 800   C) Rs. 1,200   D) Rs. 1,300   E) None of these

**DIRECTIONS for the question:** Mark the best option.

**Question No. : 47**

A person has a chemical of Rs. 25 per litre. In what ratio should water be mixed with that chemical so that after selling the mixture at Rs. 20/litre he may get a profit of 25%?

- A) 13 : 16   B) 12 : 15   C) 9 : 16   D) 19 : 22   E) None of these

**DIRECTIONS for the question:** Solve the following question and mark the best possible option.

**Question No. : 48**

Divide Rs.1200 among 100 students such that each boy got Rs. 10 and each girl get Rs. 15. Find the no.of girls.

- A) 40   B) 60   C) 25   D) 35   E) None of these

**DIRECTIONS for the question:** Answer the following question as per the best of your judgment.

**Question No. : 49**

If  $x$  and  $y$  are positive integers, is  $(2xy)^{1/2}$  an integer?

Statement 1:  $y - x = 0$

Statement 2:  $xy = 1$

Choose the correct option:

- A) If the data in statement 1 alone is sufficient to answer the question
- B) If the data in statement 2 is alone is sufficient to answer the question
- C) If the data in Both the statement together are needed to answer the question
- D) If statement 1 alone or statement 2 alone is sufficient to answer the question
- E) If neither statement 1 nor statement 2 is sufficient to answer the question

**DIRECTIONS for the question:** Solve the following question and mark the best possible option.

**Question No. : 50**

A man saves Rs. 1 on day 1, Rs. 2 on day 2, Rs. 3 on day 3 and so on. What is his total saving in the month of March?

- A) Rs.465    B) Rs.520    C) Rs.496    D) Rs.469    E) None of these

**DIRECTIONS for the question:** Solve the following question and mark the best possible option.

**Question No. : 51**

A man sells calculator at the rate of Rs. 250/- each which includes a profit of 14 percent. What amount of profit will he earn in 19 days if he sells seven calculators per day?

- A) Rs. 4665/-    B) Rs. 4565/-    C) Rs. 4545/-    D) Rs. 4655/-    E) None of these



**Question No. : 52**

**DIRECTIONS for the question:** Refer to the data below and answer the question that follows.

Following is a data about a financial company which lends out money on interest for 3 years. On failure to return the money after the stipulated period the borrower has to pay a fine of 1% per annum on the borrowed amount.

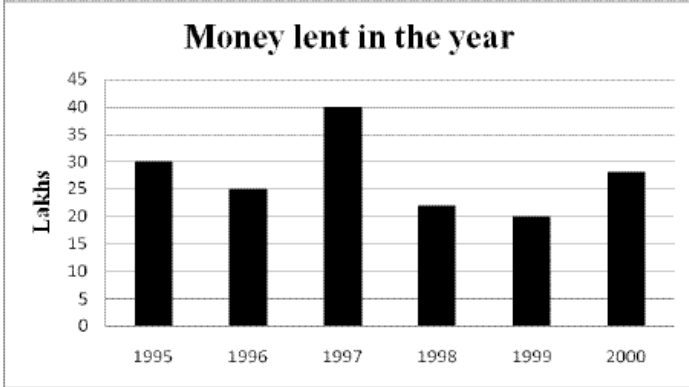

Interest Rate	
Year	% Rate
1995	13
1996	14
1997	12
1998	12
1999	12.5
2000	14

The money borrowed in 1997 was returned a year later than the due date.

The interest that was earned in 1997 is more by how much than the interest that was earned in 1996?

- A) 3.7 Lakhs   B) 1.3 Lakhs   C) 4.3 Lakhs   D) 1.8 Lakhs   E) None of these

CAREERS360

**Question No. : 53**

**DIRECTIONS for the question:** Refer to the data below and answer the question that follows.

Following is a data about a financial company which lends out money on interest for 3 years. On failure to return the money after the stipulated period the borrower has to pay a fine of 1% per annum on the borrowed amount.

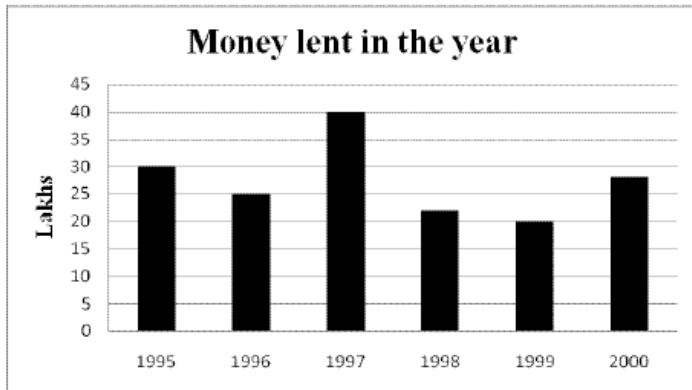

Interest Rate	
Year	% Rate
1995	13
1996	14
1997	12
1998	12
1999	12.5
2000	14

The money borrowed in 1997 was returned a year later than the due date.

If the interest rate would have been 12% throughout, what would the total earnings for 1998 and 1999 be?

- A) 5.28 Lakhs   B) 20.76 Lakhs   C) 12.96 Lakhs   D) 20.28 Lakhs   E) 15.25Lakhs

**Question No. : 54**

**DIRECTIONS for the question:** Refer to the data below and answer the question that follows.

Following is a data about a financial company which lends out money on interest for 3 years. On failure to return the money after the stipulated period the borrower has to pay a fine of 1% per annum on the borrowed amount.

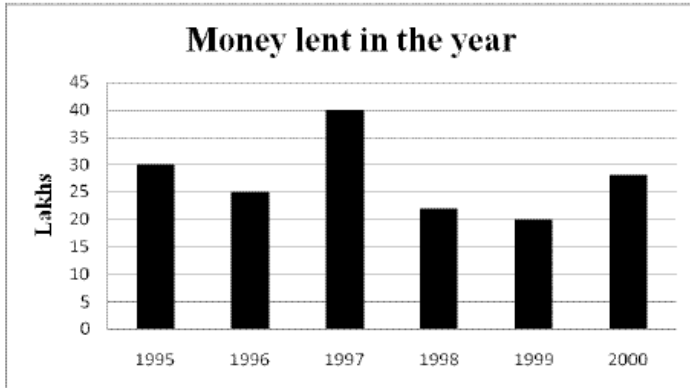

Interest Rate	
Year	% Rate
1995	13
1996	14
1997	12
1998	12
1999	12.5
2000	14

The money borrowed in 1997 was returned a year later than the due date.

What was earning in 2000?

- A) 15.73 Lakhs   B) 10.08 Lakhs   C) 16.08 Lakhs   D) 12.13 Lakhs   E) 14.1 Lakhs

**Question No. : 55**

**DIRECTIONS for the question:** Refer to the data below and answer the question that follows.

Following is a data about a financial company which lends out money on interest for 3 years. On failure to return the money after the stipulated period the borrower has to pay a fine of 1% per annum on the borrowed amount.

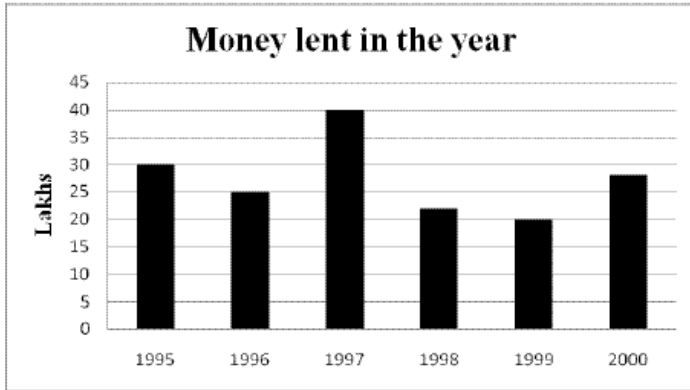

Interest Rate	
Year	% Rate
1995	13
1996	14
1997	12
1998	12
1999	12.5
2000	14

The money borrowed in 1997 was returned a year later than the due date.

If the amount lent out in 1997 would have been 20 instead of 40. What would be the difference in the interest earned in 1998. All other terms remaining the same?

- A) 2.4 Lakhs   B) 2.8 Lakhs   C) 2.0 Lakhs   D) 1.8 Lakhs   E) 1.5 Lakhs

**Question No. : 56**

**DIRECTIONS for the question:** Refer to the data below and answer the question that follows.

Following is a data about a financial company which lends out money on interest for 3 years. On failure to return the money after the stipulated period the borrower has to pay a fine of 1% per annum on the borrowed amount.

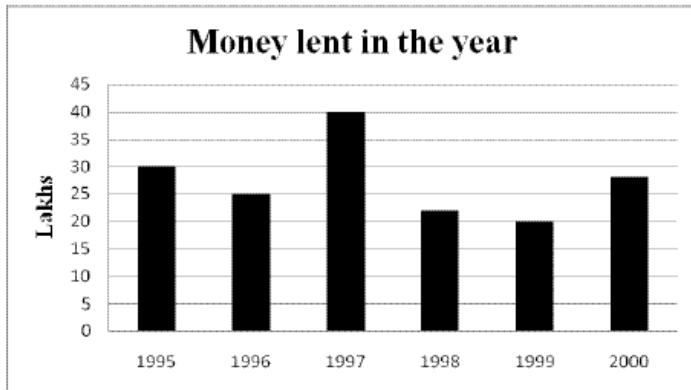

Interest Rate	
Year	% Rate
1995	13
1996	14
1997	12
1998	12
1999	12.5
2000	14

The money borrowed in 1997 was returned a year later than the due date.

The amount lent out in 1999 was half of what was lent in 1997. What was the interest difference for the two year on the amount lent out only in that particular year?

- A) 0.9 Lakhs   B) 2.3 Lakhs   C) 1.8 Lakhs   D) 1.3Lakhs   E) 3.5 Lakhs

**DIRECTIONS for the question:** Read the information given below and answer the question that follows.

**Question No. : 57**

A company produces 4 different products viz., AC, Fans, Refrigerators and Ovens each product of two different qualities i.e., Quality A and Quality B. The company produces a total of 500 products. One-fifth of total number of products are fans out of which 35% are of Quality B. Fifteen percent of the total number of products are AC. Two-third of AC's are of Quality A. Twenty five percent of the total number of products are refrigerators out of which 40 are of Quality B. Ten percent of the number of ovens are of Quality-B.

What is the total number of AC'S and ovens of Quality-B and fans and refrigerators of Quality-A together made by the company ?

- A) 165   B) 205   C) 155   D) 185   E) None of these

**DIRECTIONS for the question:** Read the information given below and answer the question that follows.

**Question No. : 58**

A company produces 4 different products viz., AC, Fans, Refrigerators and Ovens each product of two different qualities i.e., Quality A and Quality B. The company produces a total of 500 products. One-fifth of total number of products are fans out of which 35% are of Quality B. Fifteen percent of the total number of products are AC. Two-third of AC's are of Quality A. Twenty five percent of the total number of products are refrigerators out of which 40 are of Quality B. Ten percent of the number of ovens are of Quality-B.

What is the average number of products of Quality-A made by the company ?

- A) 90   B) 75   C) 80   D) 95   E) None of these

**DIRECTIONS for the question:** Read the information given below and answer the question that follows.

**Question No. : 59**

A company produces 4 different products viz., AC, Fans, Refrigerators and Ovens each product of two different qualities i.e., Quality A and Quality B. The company produces a total of 500 products. One-fifth of total number of products are fans out of which 35% are of Quality B. Fifteen percent of the total number of products are AC. Two-third of AC's are of Quality A. Twenty five percent of the total number of products are refrigerators out of which 40 are of Quality B. Ten percent of the number of ovens are of Quality-B.

What is the respective ratio between the number of ovens of Quality-B and the number of fans of Quality-A ?

- A) 5 : 2   B) 4 : 13   C) 5 : 13   D) 4 : 9   E) None of these

**DIRECTIONS for the question:** Read the information given below and answer the question that follows.

**Question No. : 60**

A company produces 4 different products viz., AC, Fans, Refrigerators and Ovens each product of two different qualities i.e., Quality A and Quality B. The company produces a total of 500 products. One-fifth of total number of products are fans out of which 35% are of Quality B. Fifteen percent of the total number of products are AC. Two-third of AC's are of Quality A. Twenty five percent of the total number of products are refrigerators out of which 40 are of Quality B. Ten percent of the number of ovens are of Quality-B.

What is the difference between the number of AC's of Quality A and Quality B?

- A) 25   B) 50   C) 35   D) 40   E) None of these

**DIRECTIONS for the question:** Read the information given below and answer the question that follows.

**Question No. : 61**

A company produces 4 different products viz., AC, Fans, Refrigerators and Ovens each product of two different qualities i.e., Quality A and Quality B. The company produces a total of 500 products. One-fifth of total number of products are fans out of which 35% are of Quality B. Fifteen percent of the total number of products are AC. Two-third of AC's are of Quality A. Twenty five percent of the total number of products are refrigerators out of which 40 are of Quality B. Ten percent of the number of ovens are of Quality-B.

Number of refrigerators of Quality-A is approximately what percentage of the total number of ovens (both Quality-A and B together) ?

- A) 39   B) 31   C) 35   D) 43   E) 49

**DIRECTIONS for the question:** Analyse the graph/s given below and answer the question that follows.

**Question No. : 62**

In a survey, 21,000 people who were owners of different devices were asked how frequently they read e-books on the device they owned.

**% of People who Own Different Devices**

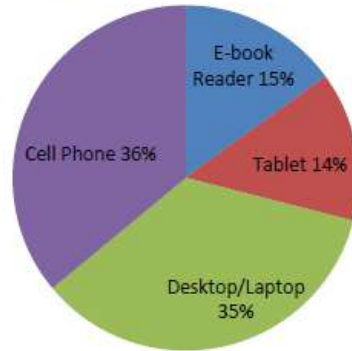

**Frequency of reading E- Books on the device**

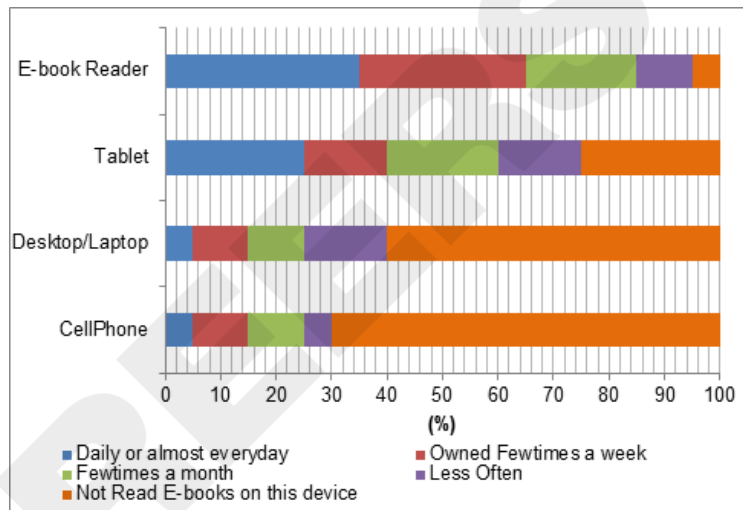

What is the difference between the number of owners of tablets who read e-books on the tablet daily or almost every day and the number of owners of tablets who read e-books less often on a tablet?

- A) 294    B) 325    C) 441    D) 524    E) 735

**DIRECTIONS for the question:** Analyse the graph/s given below and answer the question that follows.

**Question No. : 63**

In a survey, 21,000 people who were owners of different devices were asked how frequently they read e-books on the device they owned.

**% of People who Own Different Devices**

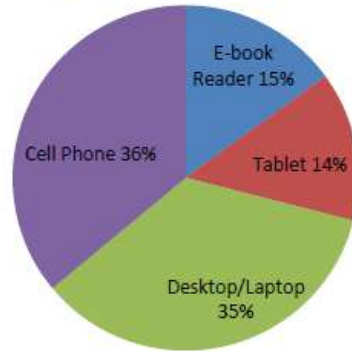

**Frequency of reading E- Books on the device**

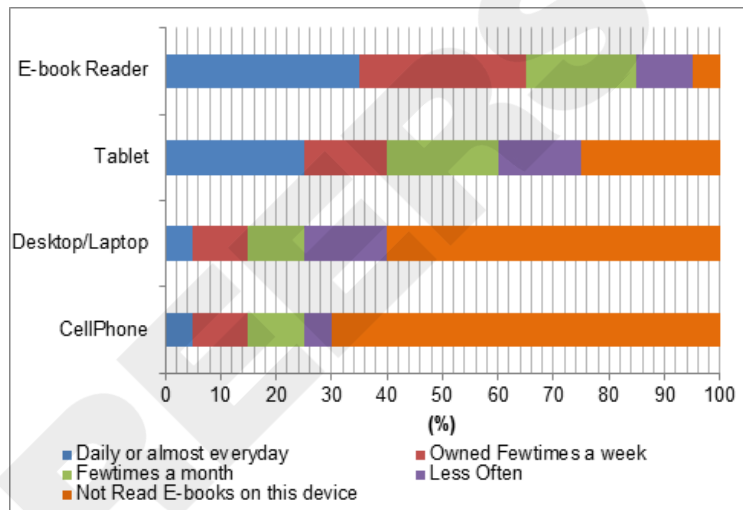

Of the total number of people who read e-books a few times a month on the device they own, approximately what percentage use their tablet to read e-books a few times a month?

- A) 21.71%    B) 28.48%    C) 32.46%    D) 38.64%    E) 45.82%

**DIRECTIONS for the question:** Analyse the graph/s given below and answer the question that follows.

**Question No. : 64**

In a survey, 21,000 people who were owners of different devices were asked how frequently they read e-books on the device they owned.

**% of People who Own Different Devices**

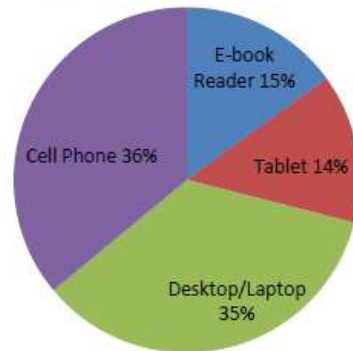

**Frequency of reading E- Books on the device**

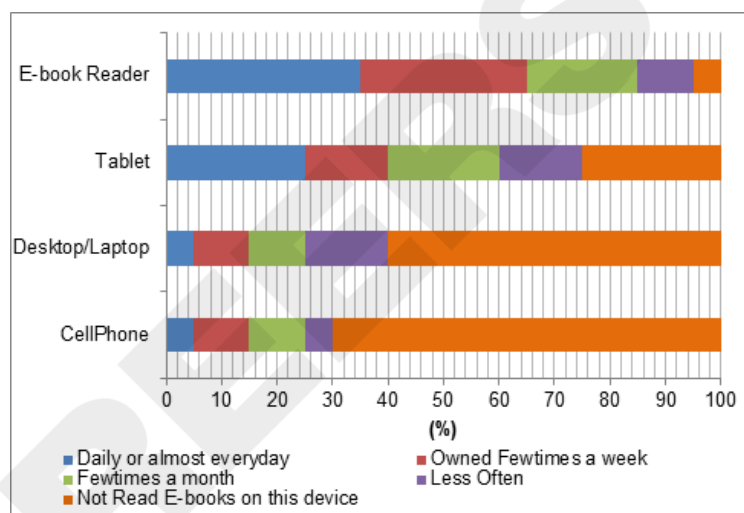

If 2/3 of the total number of people who read e-books less often on cell phones, e-book readers and tablets read e-books on these three devices only once a year, how many people read e-books on these three devices only once a year?

- A) 582    B) 624    C) 756    D) 1,134    E) 2,940

**DIRECTIONS for the question:** Solve the following question and mark the best possible option.

**Question No. : 65**

A man crosses a stationary bus in 8 seconds. The same bus crosses a pole in 4 seconds. What is the respective ratio between the speed of the bus and the speed of the man ?

- A) 9 : 2    B) 9 : 4    C) 18 : 5    D) Cannot be determined    E) None of these

**DIRECTIONS for the question:** Solve the following question and mark the best possible option.

**Question No. : 66**

Arun ordered 15 chapattis, 4 plates of rice, 6 plates of mixed vegetable and 5 ice-cream cups. The cost of one chapatti is Rs.5/-, one plate of rice is Rs.50/-, one plate of mixed vegetable is Rs.75/- and one ice-cream cup is Rs. 20/-. How much amount did Arun pay to the cashier ?

- A) Rs.850/-   B) Rs.795/-   C) Rs.825/-   D) Rs.7501/-   E) None of these

**DIRECTIONS for the question:** Solve the following question and mark the best possible option.

**Question No. : 67**

There are two circles of different radii. The area of a square is 196 sq.cms, whose side is half the radius of the larger circle. The radius of the smaller circle is three-seventh that of the larger circle. What is the circumference of the smaller circle ?

- A)  $12\pi$  cms   B)  $16\pi$  cms   C)  $24\pi$  cms   D)  $32\pi$  cms   E) None of these

**DIRECTIONS for the question:** Solve the following question and mark the best possible option.

**Question No. : 68**

The ratio between the angles of a quadrilateral is 3 : 4 : 6 : 7. Half the second largest angle of the quadrilateral is equal to the smaller angle of a parallelogram. What is the value of adjacent angle of this angle in the parallelogram ?

- A)  $136^\circ$    B)  $126^\circ$    C)  $940^\circ$    D)  $960^\circ$    E) None of these

**DIRECTIONS for the question:** Answer the following question as per the best of your judgment.

**Question No. : 69**

What is the 1<sup>st</sup> term in sequence S?

Statement 1: The 3<sup>rd</sup> term of S is 4

Statement 2: The 2<sup>nd</sup> term of S is three times the 1<sup>st</sup> and the 3<sup>rd</sup> term is four times the 2<sup>nd</sup>.

Choose the correct option:

- A) If the data in statement 1 alone is sufficient to answer the question  
B) If the data in statement 2 is alone is sufficient to answer the question  
C) If the data in Both the statement together are needed to answer the question  
D) If statement 1 alone or statement 2 alone is sufficient to answer the question  
E) If neither statement 1 nor statement 2 is sufficient to answer the question

**DIRECTIONS for the question:** The question below consist of a question and two statements numbered I and II given below it. You have to decide whether the data provided in the statements are sufficient to answer the question. Read both the statements and mark

**Question No. : 70**

A, B, C and D contested in a race. Who won the race?

I. B did not win

II. C's speed is  $2/3^{\text{rd}}$  of D's speed and D is twice as fast as B?

- A) If the question can be answered by using statement I alone, but not statement II alone.
- B) If the question can be answered by statement II alone, but not statement I alone
- C) If the question can be answered by using statement I and II together, but not by each statement alone.
- D) If the question cannot be answered even by using both the statement I and II together
- E) If the question can be answered either by using I or statement II.

**DIRECTIONS for the question :** Solve the following question and mark the best possible option.

**Question No. : 71**

$\frac{\log(97 - 56\sqrt{3})}{\log\sqrt{7 + 4\sqrt{3}}}$  equals which of the following?

- A) -2    B) -4    C) -5    D) None of the others    E) -3

**DIRECTIONS for the question:** Solve the following question and mark the best possible option.

**Question No. : 72**

In how many different ways can the letters of the word "CANDIDATE" be arranged in such a way that the vowels always come together?

- A) 4320    B) 1440    C) 720    D) 840    E) 1560

**Section : Logical Reasoning**

**DIRECTIONS for the question:** Solve the following question and mark the best possible option.

**Question No. : 73**

If CGKQW is one sequence following a logic, and another five letter sequence following similar type of logic is BFJVP, then one more variation of this type can be \_\_\_\_\_.

- A) CFKNT    B) DHLRX    C) VPJFB    D) Cannot be determined    E) None of these

**DIRECTIONS for the question:** Solve the following question and mark the best possible option.

**Question No. : 74**

In a certain code STREAMLINE is written as BFSUTDMHKL. How is SCIENTIFIC written in that code?

- A) MDHBRBHEHS    B) OFJDTBHEHS    C) MDHBRDJGJU    D) OFJDTDJGJU    E) None of these

**DIRECTIONS for the question:** Solve the following question and mark the best possible option.

**Question No. : 75**

Which of the following has the same relationship as that of JL : KM ?

- A) RT : UV   B) EF : GH   C) CE : DB   D) Cannot be determined   E) None of these

**DIRECTIONS for the question:** Go through all the options and mark the one which does not belong to the group.

**Question No. : 76**

Four of the following five are alike in a certain way and so form a group. Which is the one that does not belong to the group?

- A) 131   B) 157   C) 241   D) 217   E) 103

**DIRECTIONS for the question:** What should come in place of question mark (?) in the following number/alphabetic series?

**Question No. : 77**

C B D A E Z F ? G X

- A) Y   B) Z   C) V   D) W   E) None of these

**DIRECTIONS for the question:** The question below has either two or three statements followed by two or three conclusions. You have to take the given statements to be true and then decide which of the given conclusions logically follows from the given statements, disregarding the commonly known facts.

**Question No. : 78**

**Statements :** No table is wood. Some woods are chairs. All chairs are stones.

**Conclusions :** I. No stone is table.  
II. Some stones are woods.

- A) only conclusion I follows.   B) only conclusion II follows.   C) either conclusion I or II follows.  
D) neither conclusion I nor II follows.   E) both conclusions I and II follow.

**DIRECTIONS for the question:** The question below has either two or three statements followed by two or three conclusions. You have to take the given statements to be true and then decide which of the given conclusions logically follows from the given statements, disregarding the commonly known facts.

**Question No. : 79**

**Statements :** No blue is green. All black is blue. All letters are black.

**Conclusions :** I. No letter is green.  
II. Some blue is black.

- A) only conclusion I follows.   B) only conclusion II follows.   C) either conclusion I or II follows.  
D) neither conclusion I nor II follows.   E) both conclusions I and II follow.

**DIRECTIONS for the question:** The question below has either two or three statements followed by two or three conclusions. You have to take the given statements to be true and then decide which of the given conclusions logically follows from the given statements, disregarding the commonly known facts.

**Question No. : 80**

**Statements :** Some fruits are mangoes. Some mangoes are red. All red are vegetables.

**Conclusions :** I. No fruit is red.  
II. Some fruits are red.

A) only conclusion I follows. B) only conclusion II follows. C) either conclusion I or II follows.  
D) neither conclusion I nor II follows. E) both conclusions I and II follow.

**Question No. : 81**

**DIRECTIONS for the question:** Answer the following question based on the following information.

Seven basketball matches were played between two finalists, during national basketball competition. After the match, nine players (speculators inclusive) were being interviewed. One or more players were interviewed from the teams viz. Andhra Pradesh, Gujrat, Madhya Pradesh, Uttar Pradesh, Maharashtra, West Bengal and Bihar. The name of the team also denotes the state of the team. Additional information about the interview is as follows.

Each player has a unique jersey number.

David Disouza with jersey number 31 plays for Andhra Pradesh and is also known as a 3 point shooter.

Rajeev Sinha with jersey number 23 is the eldest player and Subhash Divyundu is the heaviest player in National Basketball competition.

Sachdeva Sharma has a jersey number 30, while Jayesh Patel has 40.

Rahul Jha is one of the drunks and he is from West Bengal.

The player from Uttar Pradesh and one player from AP have single digit jersey number.

Both the players with jersey number 40 & 34 play for Gujrat.

Rahul Jha was interviewed after Ramesh Nayudu, but wasn't the last person to be interviewed.

Both the players from AP and players from Gujrat were interviewed one after the other, and so were the players from UP, Maharashtra and West Bengal, and in that order.

Jersey 23 plays from Bihar.

The heaviest player is with Jersey Number 34.

Ramesh Nayudu is a 'passer' for Andhra Pradesh.

Jersey Number 2 and 3 were the only single digit jerseys.

Player from Maharashtra was interviewed 7<sup>th</sup>.

If David Disouza was the first to be interviewed, who could not be interviewed 2<sup>nd</sup>?

A) Ramesh Naydu B) Sachdeva Sharma C) Rahul Jha D) The eldest player E) Both C and D

**Question No. : 82**

**DIRECTIONS for the question:** Answer the following question based on the following information.

Seven basketball matches were played between two finalists, during national basketball competition. After the match, nine players (speculators inclusive) were being interviewed. One or more players were interviewed from the teams viz. Andhra Pradesh, Gujrat, Madhya Pradesh, Uttar Pradesh, Maharashtra, West Bengal and Bihar. The name of the team also denotes the state of the team. Additional information about the interview is as follows.

Each player has a unique jersey number.

David Disouza with jersey number 31 plays for Andhra Pradesh and is also known as a 3 point shooter.

Rajeev Sinha with jersey number 23 is the eldest player and Subhash Divyundu is the heaviest player in National Basketball competition.

Sachdeva Sharma has a jersey number 30, while Jayesh Patel has 40.

Rahul Jha is one of the drunkers and he is from West Bengal.

The player from Uttar Pradesh and one player from AP have single digit jersey number.

Both the players with jersey number 40 & 34 play for Gujrat.

Rahul Jha was interviewed after Ramesh Nayudu, but wasn't the last person to be interviewed.

Both the players from AP and players from Gujrat were interviewed one after the other, and so were the players from UP, Maharashtra and West Bengal, and in that order.

Jersey 23 plays from Bihar.

The heaviest player is with Jersey Number 34.

Ramesh Nayudu is a 'passer' for Andhra Pradesh.

Jersey Number 2 and 3 were the only single digit jerseys.

Player from Maharashtra was interviewed 7<sup>th</sup>.

If Anil Thakur, Akshay Kumar and Sachdev Sharma were players who got interviewed in order, then who will not be wearing Jersey number 2?

- A) Uttar Pradesh   B) Ramesh Naydu   C) Jayesh Patel   D) Anil Thakur   E) None of these

**Question No. : 83**

**DIRECTIONS for the question:** Answer the following question based on the following information.

Seven basketball matches were played between two finalists, during national basketball competition. After the match, nine players (speculators inclusive) were being interviewed. One or more players were interviewed from the teams viz. Andhra Pradesh, Gujrat, Madhya Pradesh, Uttar Pradesh, Maharashtra, West Bengal and Bihar. The name of the team also denotes the state of the team. Additional information about the interview is as follows.

Each player has a unique jersey number.

David Disouza with jersey number 31 plays for Andhra Pradesh and is also known as a 3 point shooter.

Rajeev Sinha with jersey number 23 is the eldest player and Subhash Divyundu is the heaviest player in National Basketball competition.

Sachdeva Sharma has a jersey number 30, while Jayesh Patel has 40.

Rahul Jha is one of the drunkers and he is from West Bengal.

The player from Uttar Pradesh and one player from AP have single digit jersey number.

Both the players with jersey number 40 & 34 play for Gujrat.

Rahul Jha was interviewed after Ramesh Nayudu, but wasn't the last person to be interviewed.

Both the players from AP and players from Gujrat were interviewed one after the other, and so were the players from UP, Maharashtra and West Bengal, and in that order.

Jersey 23 plays from Bihar.

The heaviest player is with Jersey Number 34.

Ramesh Nayudu is a 'passer' for Andhra Pradesh.

Jersey Number 2 and 3 were the only single digit jerseys.

Player from Maharashtra was interviewed 7<sup>th</sup>.

What may be the correct order of the interviewee's?

- A) Andhra Pradesh, Andhra Pradesh, Gujarat, Madhya Pradesh, West Bengal, Maharashtra and Bihar
- B) Andhra Pradesh, Andhra Pradesh, Madhya Pradesh, Gujarat, Uttar Pradesh, Maharashtra, West Bengal, Bihar
- C) Players from Andhra Pradesh, Gujarat, Madhya Pradesh, Uttar Pradesh, Maharashtra, West Bengal, Bihar
- D) Players with Jersey numbers 31, 2, 3, 40, 34, 17, 30, 19, 5
- E) None of these

**DIRECTIONS for the question:** Read the information given below and answer the question that follows.

**Question No. : 84**

In a local pet store, seven puppies wait to be introduced to their new owners. The puppies, named Ashlen, Blakely, Custard, Daffy, Earl, Fala, and Gabino, are all kept in two available pens. Pen 1 holds three puppies, and pen 2 holds four puppies.

If Gabino is kept in pen 1, then Daffy is not kept in pen 2.

If Daffy is not kept in pen 2, then Gabino is kept in pen 1.

If Ashlen is kept in pen 2, then Blakely is not kept in pen 2.

If Blakely is kept in pen 1, then Ashlen is not kept in pen 1.

Which of the following groups of puppies could be in pen 2?

- A) Gabino, Daffy, Custard, Earl
- B) Blakely, Gabino, Ashlen, Daffy
- C) Ashlen, Gabino, Earl, Custard
- D) Blakely, Custard, Earl, Fala
- E) Gabino, Ashlen, Fala, Earl

**DIRECTIONS for the question:** Read the information given below and answer the question that follows.

**Question No. : 85**

In a local pet store, seven puppies wait to be introduced to their new owners. The puppies, named Ashlen, Blakely, Custard, Daffy, Earl, Fala, and Gabino, are all kept in two available pens. Pen 1 holds three puppies, and pen 2 holds four puppies.

- If Gabino is kept in pen 1, then Daffy is not kept in pen 2.
- If Daffy is not kept in pen 2, then Gabino is kept in pen 1.
- If Ashlen is kept in pen 2, then Blakely is not kept in pen 2.
- If Blakely is kept in pen 1, then Ashlen is not kept in pen 1.

If Earl shares a pen with Fala, then which of the following **MUST** be true?

- A) Gabino is in pen 1 with Daffy
- B) Custard is in pen 2
- C) Ashlen, Gabino, Earl, Custard
- D) Earl is in pen 1
- E) Gabino shares a pen with Blakely

**DIRECTIONS for the question:** Read the information given below and answer the question that follows.

**Question No. : 86**

In a local pet store, seven puppies wait to be introduced to their new owners. The puppies, named Ashlen, Blakely, Custard, Daffy, Earl, Fala, and Gabino, are all kept in two available pens. Pen 1 holds three puppies, and pen 2 holds four puppies.

- If Gabino is kept in pen 1, then Daffy is not kept in pen 2.
- If Daffy is not kept in pen 2, then Gabino is kept in pen 1.
- If Ashlen is kept in pen 2, then Blakely is not kept in pen 2.
- If Blakely is kept in pen 1, then Ashlen is not kept in pen 1.

If Earl and Fala are in different pens, then which of the following **MUST NOT** be true?

- A) Fala shares a pen with Custard
- B) Gabino shares a pen with Ashlen
- C) Earl is in a higher-numbered pen than Blakely
- D) Blakely shares pen 2 with Earl and Daffy
- E) Custard is in a higher-numbered pen than Fala

**DIRECTION for the question:** Read the information given and answer the question that follows.

**Question No. : 87**

- A. In most of the urban areas basic infrastructure such as roads is in poor condition.
- B. Inadequate resources and poor planning often lead to roads being constructed with substandard material and just before the onset of rains and hence we can see a lot of potholes developing soon after.
- C. India is home to quite a large rural population. Most of the rural areas in India do not have access to all weather roads and hence have a tough time during the monsoons. This problem is more significant in the northern and north eastern part of the country.
- D. People spend more time on roads while commuting leading to loss of valuable time as well as fuel. Risk of accidents also increases manifold as the number of vehicles is increasing faster than what roads can accommodate.
- E. In order to improve the conditions of road efforts began way back in the 1980s. It is during this time that roads were built to link major highways, to expand the width of existing roads and to construct important bridges.
- F. In 1988, the National Highways Authority of India was established in India by an Act of Parliament. This autonomous entity came into existence on 15 June 1989.

which of the statements numbered (A), (B), (C), (D), (E) and (F) is the **effect** of poorly constructed roads?

- A) Only (A)
- B) Only (B)
- C) Only (D)
- D) Only (F)
- E) Only (C)

**DIRECTION for the question:** Read the information given and answer the question that follows.

**Question No. : 88**

- A. In most of the urban areas basic infrastructure such as roads is in poor condition.
- B. Inadequate resources and poor planning often lead to roads being constructed with substandard material and just before the onset of rains and hence we can see a lot of potholes developing soon after.
- C. India is home to quite a large rural population. Most of the rural areas in India do not have access to all weather roads and hence have a tough time during the monsoons. This problem is more significant in the northern and north eastern part of the country.
- D. People spend more time on roads while commuting leading to loss of valuable time as well as fuel. Risk of accidents also increases manifold as the number of vehicles is increasing faster than what roads can accommodate.
- E. In order to improve the conditions of road efforts began way back in the 1980s. It is during this time that roads were built to link major highways, to expand the width of existing roads and to construct important bridges.
- F. In 1988, the National Highways Authority of India was established in India by an Act of Parliament. This autonomous entity came into existence on 15 June 1989.

Which of the statements numbered (A), (B), (C), (E) and (F) indicate that the poor infrastructure **weakens** the economy of our country ?

- A) Only (A)   B) Only (C)   C) Only (D)   D) Both (C) and (D)   E) Both (D) and (E)

**DIRECTION for the question:** Read the information given and answer the question that follows.

**Question No. : 89**

- A. In most of the urban areas basic infrastructure such as roads is in poor condition.
- B. Inadequate resources and poor planning often lead to roads being constructed with substandard material and just before the onset of rains and hence we can see a lot of potholes developing soon after.
- C. India is home to quite a large rural population. Most of the rural areas in India do not have access to all weather roads and hence have a tough time during the monsoons. This problem is more significant in the northern and north eastern part of the country.
- D. People spend more time on roads while commuting leading to loss of valuable time as well as fuel. Risk of accidents also increases manifold as the number of vehicles is increasing faster than what roads can accommodate.
- E. In order to improve the conditions of road efforts began way back in the 1980s. It is during this time that roads were built to link major highways, to expand the width of existing roads and to construct important bridges.
- F. In 1988, the National Highways Authority of India was established in India by an Act of Parliament. This autonomous entity came into existence on 15 June 1989.

Which of the statements (A), (B), (C), (D) and (E) mentioned above a **reason** for the dilapidated conditions of roads ?

- A) Only (A)   B) Only (B)   C) Only (D)   D) Both (A) and (D)   E) Both (C) and (E)

**DIRECTION for the question:** Read the information given and answer the question that follows.

**Question No. : 90**

- A. In most of the urban areas basic infrastructure such as roads is in poor condition.
- B. Inadequate resources and poor planning often lead to roads being constructed with substandard material and just before the onset of rains and hence we can see a lot of potholes developing soon after.
- C. India is home to quite a large rural population. Most of the rural areas in India do not have access to all weather roads and hence have a tough time during the monsoons. This problem is more significant in the northern and north eastern part of the country.
- D. People spend more time on roads while commuting leading to loss of valuable time as well as fuel. Risk of accidents also increases manifold as the number of vehicles is increasing faster than what roads can accommodate.
- E. In order to improve the conditions of road efforts began way back in the 1980s. It is during this time that roads were built to link major highways, to expand the width of existing roads and to construct important bridges.
- F. In 1988, the National Highways Authority of India was established in India by an Act of Parliament. This autonomous entity came into existence on 15 June 1989.

Which of the statements numbered (A), (B), (C), (E) and (F) mentioned above can be termed as a relevant **course of action** adopted by govt. of India in order to solve the problem of poor roads?

- A) Only (F)   B) Only (B)   C) Only (E)   D) Only (C)   E) Only (A)

**DIRECTION for the question:** Read the information given and answer the question that follows.

**Question No. : 91**

100 per cent foreign direct investments in single brand retail and 51 percent in multi-brand retail, allowed in India. Foreign retailers entering India's multi-brand segment will have to put 50 percent of their investments in back – end Infrastructure. This is going to generate employment.

Which of the following can be inferred from the passage?

- A) Foreign direct investment will be good for the economy but in controlled manner and with restrictions implied.
- B) India has taken a wrong step in allowing investment from other countries.
- C) Foreign investors may misuse the infrastructure and harm the nation   D) Indians banks will suffer as a result
- E) The scheme is going to collapse.

**DIRECTIONS for the question:** Read the information given below and answer the question that follows.

**Question No. : 92**

There are eight employees P, Q, R, S, U, V, W and T working with banks, namely BOB, UCO, PNB, HDFC, SBI, RBI, Axis and ICICI. All of them are sitting around a circular table and facing the centre but not necessarily in the same order. W is working with PNB and doesn't sit between Q and R. S sits second to the left of the person who is working with PNB and opposite U. P works with the UCO Bank and is fourth to the left of R and does not sit on the immediate left of the person who is working with the Axis Bank. The person who is working with RBI sits between those two persons who are working with SBI and the UCO Bank respectively. Q works with SBI and is third to the left of the person who is working with PNB. The person working with Axis Bank faces W, who is on the immediate left of the person who is working with HDFC. The person working with RBI sits third to the right of the person working with BOB.

Who works with BOB?

- A) P   B) Q   C) R   D) Can't be determined   E) None of these

**DIRECTIONS for the question:** Read the information given below and answer the question that follows.

**Question No. : 93**

There are eight employees P, Q, R, S, U, V, W and T working with banks, namely BOB, UCO, PNB, HDFC, SBI, RBI, Axis and ICICI. All of them are sitting around a circular table and facing the centre but not necessarily in the same order. W is working with PNB and doesn't sit between Q and R. S sits second to the left of the person who is working with PNB and opposite U. P works with the UCO Bank and is fourth to the left of R and does not sit on the immediate left of the person who is working with the Axis Bank. The person who is working with RBI sits between those two persons who are working with SBI and the UCO Bank respectively. Q works with SBI and is third to the left of the person who is working with PNB. The person working with Axis Bank faces W, who is on the immediate left of the person who is working with HDFC. The person working with RBI sits third to the right of the person working with BOB.

How many employees are sitting between R and Q? (if counted in anticlockwise direction starting from R)

- A) Two B) Three C) Four D) Five E) None of these

**DIRECTIONS for the question:** Read the information given below and answer the question that follows.

**Question No. : 94**

There are eight employees P, Q, R, S, U, V, W and T working with banks, namely BOB, UCO, PNB, HDFC, SBI, RBI, Axis and ICICI. All of them are sitting around a circular table and facing the centre but not necessarily in the same order. W is working with PNB and doesn't sit between Q and R. S sits second to the left of the person who is working with PNB and opposite U. P works with the UCO Bank and is fourth to the left of R and does not sit on the immediate left of the person who is working with the Axis Bank. The person who is working with RBI sits between those two persons who are working with SBI and the UCO Bank respectively. Q works with SBI and is third to the left of the person who is working with PNB. The person working with Axis Bank faces W, who is on the immediate left of the person who is working with HDFC. The person working with RBI sits third to the right of the person working with BOB.

Who works in HDFC Bank?

- A) U B) W C) Q D) Either V or T E) None of these

**DIRECTIONS for the question:** Given an input line ; the machine arranges the words and numbers in steps in a systematic manner as illustrated afterwards : Study the pattern and answer the question that follows.

**Question No. : 95**

A word and number arrangement machine when given an input line of words and numbers rearranges them following a particular rule. The following is an illustration of input and rearrangement, steps

Input : why is 25 bigger than 14 but smaller than 32

Step I : than 14 why is 25 bigger but smaller than 32

Step II : than 14 is 25 why bigger but smaller than 32

Step III : than 14 is 25 than 32 why bigger but smaller

Step IV : than 14 is 25 than 32 why smaller bigger but

Step V : than 14 is 25 than 32 why smaller but bigger

and Step V is the last step of the rearrangement of the above input as the intended re-arrangement is obtained

As per the rules followed in the above steps, indicate the answer in each of the following questions with respect to the appropriate step for the given input.

**Input for the questions**

Any number less than 30 and more than 20 does not equal 40

Which step number would be the following output ?

than 20 any number less than 30 and more does not equal 40

- A) III B) IV C) V D) VI E) None of these

**DIRECTIONS for the question:** Given an input line ; the machine arranges the words and numbers in steps in a systematic manner as illustrated afterwards : Study the pattern and answer the question that follows.

**Question No. : 96**

A word and number arrangement machine when given an input line of words and numbers rearranges them following a particular rule. The following is an illustration of input and rearrangement, steps

Input : why is 25 bigger than 14 but smaller than 32

Step I : than 14 why is 25 bigger but smaller than 32

Step II : than 14 is 25 why bigger but smaller than 32

Step III : than 14 is 25 than 32 why bigger but smaller

Step IV : than 14 is 25 than 32 why smaller bigger but

Step V : than 14 is 25 than 32 why smaller but bigger

and Step V is the last step of the rearrangement of the above input as the intended re-arrangement is obtained

As per the rules followed in the above steps, indicate the answer in each of the following questions with respect to the appropriate step for the given input.

**Input for the questions**

Any number less than 30 and more than 20 does not equal 40

How many steps would be needed to complete the arrangement ?

A) X B) VIII C) IX D) VII E) None of these

**DIRECTIONS for the question:** Given an input line ; the machine arranges the words and numbers in steps in a systematic manner as illustrated afterwards : Study the pattern and answer the question that follows.

**Question No. : 97**

A word and number arrangement machine when given an input line of words and numbers rearranges them following a particular rule. The following is an illustration of input and rearrangement, steps

Input : why is 25 bigger than 14 but smaller than 32

Step I : than 14 why is 25 bigger but smaller than 32

Step II : than 14 is 25 why bigger but smaller than 32

Step III : than 14 is 25 than 32 why bigger but smaller

Step IV : than 14 is 25 than 32 why smaller bigger but

Step V : than 14 is 25 than 32 why smaller but bigger

and Step V is the last step of the rearrangement of the above input as the intended re-arrangement is obtained

As per the rules followed in the above steps, indicate the answer in each of the following questions with respect to the appropriate step for the given input.

**Input for the questions**

Any number less than 30 and more than 20 does not equal 40

Which of the following would be Step IV ?

A) than 20 than 30 equal 40 any number less and more does not

B) than 20 any number less than 30 and more does not equal 40

C) 20 30 40 than equal number any less and more does not

D) 20 than 30 than 40 equal number any less and more does not E) None of these

**DIRECTIONS for the question:** Given an input line ; the machine arranges the words and numbers in steps in a systematic manner as illustrated afterwards : Study the pattern and answer the question that follows.

**Question No. : 98**

A word and number arrangement machine when given an input line of words and numbers rearranges them following a particular rule. The following is an illustration of input and rearrangement, steps

Input : why is 25 bigger than 14 but smaller than 32

Step I : than 14 why is 25 bigger but smaller than 32

Step II : than 14 is 25 why bigger but smaller than 32

Step III : than 14 is 25 than 32 why bigger but smaller

Step IV : than 14 is 25 than 32 why smaller bigger but

Step V : than 14 is 25 than 32 why smaller but bigger

and Step V is the last step of the rearrangement of the above input as the intended re-arrangement is obtained

As per the rules followed in the above steps, indicate the answer in each of the following questions with respect to the appropriate step for the given input.

**Input for the questions**

Any number less than 30 and more than 20 does not equal 40

Which of the following would be the Step II?

A) 20 than 30 than any number less and more does not equal 40

B) than 20 than 30 equal 40 any number less and more does not

C) than 20 than 30 any number less and more does not equal 40

D) than 20 than 30 any number less and more does not 40 equal E) None of these

**DIRECTIONS for the question:** Given an input line ; the machine arranges the words and numbers in steps in a systematic manner as illustrated afterwards : Study the pattern and answer the question that follows.

**Question No. : 99**

A word and number arrangement machine when given an input line of words and numbers rearranges them following a particular rule. The following is an illustration of input and rearrangement, steps

Input : why is 25 bigger than 14 but smaller than 32

Step I : than 14 why is 25 bigger but smaller than 32

Step II : than 14 is 25 why bigger but smaller than 32

Step III : than 14 is 25 than 32 why bigger but smaller

Step IV : than 14 is 25 than 32 why smaller bigger but

Step V : than 14 is 25 than 32 why smaller but bigger

and Step V is the last step of the rearrangement of the above input as the intended re-arrangement is obtained

As per the rules followed in the above steps, indicate the answer in each of the following questions with respect to the appropriate step for the given input.

**Input for the questions**

Any number less than 30 and more than 20 does not equal 40

Which word/number would be on 6th position from left side in Step V?

A) any B) not C) 40 D) number E) None of these

**DIRECTIONS for the question:** What should come in place of question mark (?) in the following number/alphabetic series?

**Question No. : 100**

210 209 213 186 202 (?)

A) 138 B) 77 C) 177 D) 327 E) None of these

**DIRECTIONS for the question:** What should come in place of question mark (?) in the following number/alphabetic series?

**Question No. : 101**

444    467    513    582    674    789    (?)

A) 950    B) 881    C) 998    D) 905    E) None of these

**DIRECTIONS for the question:** Solve the following question and mark the best possible option.

**Question No. : 102**

P is the father of D. D is the only son of T. T is the daughter of J. T is the mother of G. G is the sister of V.

If J is married to B, then how is B related to G?

A) Daughter-in-law    B) Son-in-law    C) Father    D) Mother    E) Cannot be determined

**DIRECTIONS for the question:** Solve the following question and mark the best possible option.

**Question No. : 103**

P is the father of D. D is the only son of T. T is the daughter of J. T is the mother of G. G is the sister of V.

How is V related to P?

A) Daughter    B) Father    C) Mother    D) Cannot be determined    E) Son

**DIRECTION for the question:** Answer the question based on the information given in the passage.

**Question No. : 104**

Today, the power of Photo-editing power is available to anyone with a smartphone. Snapchat, Instagram and other apps make it easy to modify, augment and distort photographs. Celebrities get called out for ham-fisted photo-tweaking, though it mostly goes unnoticed. Chinese "meitu" apps let selfie-snappers alter their bone structure, skin tone and complexion. Syria's government regularly fakes pictures; Iran was caught after it edited shots of a missile launch to make it look more impressive. Image manipulation is rife, and video is the next frontier: already, experimental systems can take video of someone talking, and adjust their lip movements to make them appear to say anything. Studies show that people are generally bad at spotting manipulated images.

Which of the following best captures the implications of the concept mentioned in the passage?

A) Photography's relationship with the truth seems to have been damaged beyond repair.  
B) Deliberate misrepresentation of truth is the need of the hour    C) Photography is rarely a true representation of reality  
D) Reality is far and beyond from its representation  
E) Manipulation of images represents the basic character flaw of the people

**DIRECTION for the question:** Answer the question based on the information given in the passage.

**Question No. : 105**

There have been numerous appears to a local news paper to publish a story by angry parents a children who require remedial help. about Protection of child rights. highlighting the fact that XY High School has allegedly been demanding fees over and above the annual fees for conducting remedial classes for special children i.e. children who need additional help.

- A. As per the government rules it is the teacher's responsibility to assess the learning ability of each child and accordingly supplement additional instructions, if any, as required.
- B. Parents should file a complaint in the local police and collectively appear in the court of law in order to ensure that all special students received remedial help.
- C. Many private schools are known for charging extra fee for remedial classes.
- D. Some parents are considering other schools for their children as they do not wish to pay the extra charge levied by the school for remedial education
- E. Providing remedial education to students is very expensive and the management of the school charges a minimum amount apart from school fee to ensure that best possible help is provided to students
- F. Despite the fact that the annual fee of XY high school is over Rs. 30,000 the parents are forced to pay the extra fees and if they are unable to do so the child is not allowed to attend the remedial classes

Which of the following strengthens the stand of the parents who are angry because of the school's decision to change an extra amount as fees for remedial education?

- A) Only D   B) Only A   C) Both C and F   D) Only C   E) Both A and F

**DIRECTION for the question:** Solve the following question and mark the best possible option.

**Question No. : 106**

As they prepare for the state championships, one gymnast must be moved from the Level 2 team to the Level 1 team. The coaches will move the gymnast who has won the biggest prize and who has the most experience. In the last competition, Roberta won a bronze medal and has competed seven times before. Jamie has won a silver medal and has competed fewer times than Roberta. Beth has won a higher medal than Jamie and has competed more times than Roberta. Michele has won a bronze medal, and it is her third time competing. Who will be moved to the Level 1 team?

- A) Roberta   B) Beth   C) Michelle   D) Jamie   E) None of these

**DIRECTION for the question:** Solve the following question and mark the best possible option.

**Question No. : 107**

In a four-day period Monday through Thursday each of the following temporary office workers worked only one day, each a different day. Ms. Johnson was scheduled to work on Monday, but she traded with Mr. Carter, who was originally scheduled to work on Wednesday. Ms. Falk traded with Mr. Kirk, who was originally scheduled to work on Thursday. After all the switching was done, who worked on Tuesday?

- A) Mr. Carter   B) Ms. Falk   C) Ms. Johnson   D) Mr. Kirk   E) Can't Say

**DIRECTIONS for the question:** In the question below, a statement is followed by two courses of action numbered I and II. You have to assume everything in the statement to be true and on the basis of the information given in the statement. Mark your answer as

**Question No. : 108**

Statement : Water table in most parts of the State has gone down to such a level that its extraction for irrigation purposes is not economical any more.

Courses of action: I. Extraction of ground water for any purpose in the State should be banned for some time in order to replenish

the water table.

II. The Government should make provisions for alternative methods of irrigation so that the farmers are not compelled to use ground water.

A) it only I follows    B) if only II follows    C) if either I or II follows    D) if neither I nor II follows    E) if both I and II follow

**QNo:- 1 ,Correct Answer:- E**

**Explanation:-**

The first pair of sentences that you need to identify to solve the question is CDB. It is linked by the common topic of Angelina Jolie and Brad Pitt. Statement C introduces the couple for the first time, and statements D and B take the topic forward. Statement E forms the generic opening sentence of the paragraph, and with these two clues, we can identify option (e) as the correct answer.

**QNo:- 2 ,Correct Answer:- D**

**Explanation:-**

The pair AC helps us solve the question within a few seconds. The pair links the statements of the police officer and is present only in one option, that is option (d).

**QNo:- 3 ,Correct Answer:- D**

**Explanation:-**

The first statement in this case is statement D (most generic statement). It is followed by statement C. DC forms a pair as it talks about trading of wildlife. It is then taken forward by statement A. Statement B forms a pair with statement A. The pair BA talks about trade of animal products.

**QNo:- 4 ,Correct Answer:- D**

**Explanation:-**

Statement D is the opening sentence (most generic sentence), and it is followed by statement A which can be identified with the help of the correct pronoun 'he'. This is then taken forward by B, with which D forms a mandatory pair (D explains the contours of the foreign policy).

**QNo:- 5 ,Correct Answer:- A**

**Explanation:-**

Scabrous means jagged and rough. Level means smooth and glossy and is thus its antonym. The meanings of the other words are highlighted below:

Unkind: Ruthless

Stubborn: Obstinate

Pitiless: Merciless

Stable: Steady.

**QNo:- 6 ,Correct Answer:- A**

**Explanation:-**

*Pinnacle means the highest point while nadir means the lowest point. Hence, option A is the right choice. The meanings of the other words are highlighted below:*

*Inferior: Of or characteristic of low rank or importance*

*Climax: The highest point of anything conceived of as growing or developing or unfolding*

*Current: Occurring in or belonging to the present time*

*Apogee: A final climactic stage*

**QNo:- 7 ,Correct Answer:- B**

**Explanation:-**

*Waver means to be indecisive. Persist is its opposite. Option (b) is thus the right choice. The meanings of the other words are highlighted below:*

*Grasp: Hold firmly*

*Despicable: Morally reprehensible*

*Unruly: Noisy and lacking in restraint or discipline*

*Dither: Act nervously; be undecided; be uncertain*

**QNo:- 8 ,Correct Answer:- D**

**Explanation:-**

*Blaze means to burn with a sudden burst of flame. Inferno, which means a very intense and uncontrolled fire, is thus the right synonym for it. The meanings of the other words are highlighted below:*

*Explosion: The act of exploding or bursting*

*Touchiness: Feeling easily irritated*

*Perceptiveness: A feeling of understanding*

*Ignition: The process of initiating combustion or catching fire*

**QNo:- 9 ,Correct Answer:- C**

**Explanation:-**

*Remiss means someone who does not care/ failing in what duty requires; slipshod which means careless, is thus the right choice here. The meanings of the other words are highlighted below:*

*Coarse: Of textures that are rough to the touch or substances consisting of relatively large particles*

*Ominous: Threatening or foreshadowing evil or tragic developments*

*Dinghy: A small boat of shallow draft with cross thwarts for seats and rowlocks for oars with which it is propelled*

*Jagged: Having a sharply uneven surface or outline*

**QNo:- 10 ,Correct Answer:- C**

**Explanation:-**

*Audacity refers to aggressive boldness or unmitigated effrontery. Thus, option (c) is the correct answer. The meanings of the other words are highlighted below:*

*Entwine: Tie or link together*

*Pokerfaced: Deliberately impassive in manner*

*Wantonness: The trait of lacking restraint or control; reckless freedom from inhibition or worry*

*Shamelessness: Behaviour marked by a bold defiance of the proprieties and lack of shame*

**QNo:- 11 ,Correct Answer:- C**

**Explanation:-**

*With a flea in one's ear' means to be rebuked.*

**QNo:- 12 ,Correct Answer:- C**

**Explanation:-**

*An implacable person cannot be placated or appeased. Similarly, an unconquerable person cannot be subdued.*

**QNo:- 13 ,Correct Answer:- C**

**Explanation:-**

*In the given case, let us explore the original relationship first. An ascetic (Practising great self-denial) cannot be indulged. Similarly, a debauched (Corrupt morally or by intemperance or sensuality) person cannot be restrained.*

**QNo:- 14 ,Correct Answer:- B**

**Explanation:-**

*In the first blank, we require a word that showcases how star-struck silliness is all around us. The gist of the paragraph itself is about the presence of such behavior in society and how this is detrimental. Keeping this in mind, we find option (b) to be the best answer in the given case.*

**QNo:- 15 ,Correct Answer:- E**

**Explanation:-**

*In this case, we need a word which shows how rules are bent for celebrities. The word which accomplishes the job for us in the given case is compromise, which effectively refers to how concessions are made with rules in the case of celebrities.*

**QNo:- 16 ,Correct Answer:- B**

**Explanation:-**

*In this case, we need a word that highlights how the demands of VIPs are being fulfilled. The word which accomplishes this job is 'cater'.*

**QNo:- 17 ,Correct Answer:- A**

**Explanation:-**

*In this word, we need a negative word that gels with the sentiments being expressed by the rest of the sentence. We find this negative word in 'highhanded', which essentially means 'Given to arrogant disregard of others', that is not bothered about others. This perfectly fits the context of our paragraph and thus is the correct choice in this case.*

**QNo:- 18 ,Correct Answer:- D**

**Explanation:-**

*The pronouns and nouns that refer to the plural noun elephants have to be plural. This is not the case in options (a), (b), and (c) which use the singular pronoun 'it'. This is rectified by option (d). Also, option (e) uses the incorrect tense form and also uses the singular noun 'animal' whereas it needs to use the plural noun 'animals'.*

**QNo:- 19 ,Correct Answer:- D**

**Explanation:-**

The correct sentence is: Just when Calcutta, the capital of street protests, thought that it had been there, seen that and done that, comes an unparalleled event: a protest to champion the cause of thieves. Therefore the correct answer is PRQS

**QNo:- 20 ,Correct Answer:- C**

**Explanation:-**

The first thing that you should do in this question is identify a word that fits the context and they try to identify a synonym for the same sentiment. Here, the best fit is 'basic', which essentially refers to an in-born instinct of a person to defend his own self when criticized. This sentiment can be best replaced in the blank by primal, which means having existed from the beginning; in an earliest or original stage or state.

**QNo:- 21 ,Correct Answer:- D**

**Explanation:-**

The first sentence requires 'from'. The correct sentence is: The story of the poor woodcutter who discovered a thieves' den full of treasure may have come from Syria or Cyprus; it certainly did not come from India.  
The second sentence requires 'but'. The correct sentence is: Travel in India may be exciting, unexpected, troublesome, romantic, incredible, but embarking on the adventure has always been forbidding, for getting a visa is often like getting a ticket to the moon.  
The third sentence requires 'on'. The correct sentence is: Things might change somewhat with the electronic travel authorization and the expansion of the visa-on-arrival schemes that the Centre has decided on.

**QNo:- 22 ,Correct Answer:- C**

**Explanation:-**

The first sentence requires 'by'. The correct sentence is: Stalled power projects in the country could be recharged with the government's action plan to increase generating capacity by asking banks to help revive such projects and by providing fuel linkages.  
The second sentence requires 'out'. The correct sentence is: Power minister Piyush Goyal today met oil minister Dharmendra Pradhan to chalk out the rescue package that may involve rescheduling of loans to power companies as well as making available fuel at affordable prices by pooling cheaper domestic gas price with costly imported LNG.  
The third sentence requires 'of'. The correct sentence is: The two ministers did not divulge details of the rescue package finalised today which may need the cabinet's approval.

**QNo:- 23 ,Correct Answer:- B**

**Explanation:-**

"...purely because the global canvass is too large and often beyond the capacity of intelligent comprehension." This implies a geographically delimited space.

**QNo:- 24 ,Correct Answer:- D**

**Explanation:-**

Magic refers to "a sense of wonderment, surprise and eventual delight; a coming within reach of power and profits".

**QNo:- 25 ,Correct Answer:- C**

**Explanation:-**

"...ideas that provide us with a rich yet incomplete landscape....global canvass is too large and often beyond the capacity of intelligent comprehension."

**QNo:- 26 ,Correct Answer:- A**

**Explanation:-**

Directly stated: "specific solutions prised out of the armoured covers of sector-specific industrial structures and often resources-determined mindsets that Indian software firms seems to have mastered."

**QNo:- 27 ,Correct Answer:- C**

**Explanation:-** (A) No. A tribal system would not be part of mainstream society.

(B) No. Preserving Native American language would work against assimilation.

**(C) Yes. The policy of readjustment "encouraged the assimilation of Native Americans as individuals into mainstream society."**

(D) No. This seems the complete opposite of readjustment. Large-scale effort presumably by government. Give them their land and have them separate, not assimilating.

(E) No. This is opposing. Obligations means continued involvement. It may not stop assimilation, but it strong involvement.

**QNo:- 28 ,Correct Answer:- A**

**Explanation:-** (A) Yes. This is stated in the last paragraph: "As a result of the 1956 meeting, the Oneida rejected read justment. Instead, they determined to improve tribal life by lobbying for federal monies for postsecondary education, for the improvement of drainage on tribal lands, and for the building of a convalescent home for tribal members."

(B) No. This is not mentioned in the passage.

(C) No. This is not mentioned in the passage.

(D) No. This is not mentioned in the passage.

(E) No. This is not mentioned in the passage.

**QNo:- 29 ,Correct Answer:- A**

**Explanation:-** (A) Yes. As is often the case with reading passages, the first paragraph sets the stage for the discussion to follow. It presents two opposing social policies without indicating a preference.

(B) No. The first paragraph does present two conflicting positions. However, the rest of the passage recounts an example illustrating the conflict rather than defending one position as better than the other.

(C) No. The first paragraph introduces two policies for Native American relations. These are distinct social policies, not interpretations of a historical conflict. Furthermore, the passage does not compare the policies.

(D) No. There is no analysis nor prediction in the first paragraph. It is merely introducing two competing social movements.

(E) No. The first paragraph merely outlines the relationship between the Bureau of Indian Affairs and the Oneida tribe in the 1940s and 1950s. It does not outline the history of the BIA.

**QNo:- 30 ,Correct Answer:- A**

**Explanation:-** (A) Yes. As is often the case with reading passages, the first paragraph sets the stage for the discussion to follow. It presents two opposing social policies without indicating a preference.

(B) No. The first paragraph does present two conflicting positions. However, the rest of the passage recounts an example illustrating the conflict rather than defending one position as better than the other.

(C) No. The first paragraph introduces two policies for Native American relations. These are distinct social policies, not interpretations of a historical conflict. Furthermore, the passage does not compare the policies.

(D) No. There is no analysis nor prediction in the first paragraph. It is merely introducing two competing social movements.

(E) No. The first paragraph merely outlines the relationship between the Bureau of Indian Affairs and the Oneida tribe in the 1940s and 1950s. It does not outline the history of the BIA.

**QNo:- 31 ,Correct Answer:- D**

**Explanation:-**

The first sentence requires 'to'. The correct sentence is: The naming of cats, according to a famous poet, is a difficult matter: "It isn't just one of your holiday games."

The second sentence requires 'with'. The correct sentence is: Most eminent politicians in India would agree with the seriousness of such matters — except that 'cats', in their case, would have to be substituted by public institutions, facilities and welfare schemes.

The third sentence requires 'than'. The correct sentence is: Naming a new university, hospital, flyover or rural yojana is much more than what the usual business of civic commemoration might suggest in a modern democracy.

**QNo:- 32 ,Correct Answer:- B**

**Explanation:-**

The first sentence requires 'its'. The correct sentence is: The once-dominant international cartel of oil producers is losing its sway over the global energy markets as oil prices continue to plummet.

The second sentence requires 'up'. The correct sentence is: At its meeting tomorrow in Vienna, the Organisation of the Petroleum Exporting Countries, the group of 12 oil producing nations, is under pressure to at least announce modest cuts in an effort to shore up the markets.

The third sentence requires 'even'. But any cuts would be modest and would probably do little to prop up oil prices, assuming the countries even stick to an agreement.

**QNo:- 33 ,Correct Answer:- E**

**Explanation:-**

The paragraph talks about the importance and the beauty of the Hopi names, which European thinkers are unable to understand/identify, therefore, option 5 is correct. Option 3 though seems to be close but to say that they were not able to understand the tribal culture/linguistics would be wrong as they understood the culture but not the significance of the names given. Hence option 3 rejected.

**QNo:- 34 ,Correct Answer:- B**

**Explanation:-**

Refer to third para, third last line . " The condensed image ..... tiny imagist poems"

**QNo:- 35 ,Correct Answer:- E**

**Explanation:-**

It has been mentioned in the first paragraph, in the lines "in anthropology, Claude Levi-Strauss's characterization of names as being primarily instruments of social classification has been very influential. Consequently, interpretation of personal names in societies where names have other functions and meanings has been neglected", hence answer is option 5.

**QNo:- 36 ,Correct Answer:- D**

**Explanation:-**

The second paragraph is further describing Hopi names that names sometimes signify meanings also and it is clear from the lines "Thus, a name might translate to something as simple as "little rabbit," which reflects both the child's size and the representative animal". Hence answer is option 4.

**QNo:- 37 ,Correct Answer:- B**

**Explanation:-**

Let the angles of quadrilateral be  $2x$ ,  $4x$ ,  $7x$ ,  $5x$ .

Thus,  $2x + 4x + 7x + 5x = 360^\circ$

$18x = 360^\circ \Rightarrow x = 20^\circ$

$\therefore$  Smallest angle of triangle & quadrilateral =  $40^\circ$

Another angle of triangle =  $2 \times 40^\circ = 80^\circ$

So, 3<sup>rd</sup> angle of triangle will be  $180^\circ - 80^\circ - 40^\circ = 60^\circ$

Option (2) is the correct answer.

**QNo:- 38 ,Correct Answer:- D**

**Explanation:-**

Commission on 1 notebook =  $45 \times \frac{4}{100}$

Commission on 1 pencil box =  $80 \times \frac{20}{100}$

Commission earned on each day

$= 10 \times 45 \times \frac{4}{100} + 6 \times 80 \times \frac{20}{100} = 18 + 96 = 114$

Therefore, commission earned in 2 weeks = Rs.  $114 \times 14 =$  Rs. 1596/-

Hence, option D is the correct answer.

**QNo:- 39 ,Correct Answer:- E**

**Explanation:-**

Required non-defective printers =  $0.35 \times 0.98 + 0.3 \times 0.96 + 0.35 \times 0.97 = 0.343 + 0.288 + .34 = 0.971 = 97\%$ (approx)

**SHORT-CUT** : Otherwise they have 98, 96, 97 non defective items respectively. When their combined average is taken it will fall within these limits only. Seeing that all the options but E are either less than 96 or more than 98.

Hence, option E is the correct answer.

**QNo:- 40 ,Correct Answer:- A**

**Explanation:-**

$$8M \times 20 = 8W \times 32 \Rightarrow 5M = 8W$$

$$\text{Thus, } 5M + 8W = 5M + 5M = 10 \text{ Men.}$$

$$8 \text{ Men } \quad 20 \text{ days}$$

$$10 \text{ Men } \quad ? \text{ days}$$

$$\text{No. of days required} = 20 \times \frac{8}{10} = 16 \text{ days.}$$

Hence, option A is the correct answer.

**QNo:- 41 ,Correct Answer:- E**

**Explanation:-**

$$\text{Area of square} = 1024 \text{ sq. cms.}$$

$$\text{Thus, side of the square} = 32 \text{ cms.}$$

$$\therefore \text{Length of rectangle} = 2 \times 32 = 64 \text{ cms.}$$

$$\& \text{ Breadth of rectangle} = 32 - 12 = 20 \text{ cms.}$$

$$\text{Hence } \frac{L}{B} = \frac{64}{20} = \frac{16}{5}$$

Hence, option E is the correct answer.

**QNo:- 42 ,Correct Answer:- E**

**Explanation:-**

Let the 5 consecutive even numbers be  $2n, 2n+2, 2n+4, 2n+6, 2n+8$

$$\Rightarrow 2n + 2n+2 + 2n+4 + 2n+6 + 2n+8 = 220$$

$$\Rightarrow 10n + 20 = 220$$

$$\Rightarrow n = 20$$

Hence, Set A = {40, 42, 44, 46, 48}

A no. 37 less than double of the lowest no. of set A will be  $= 2 \times 40 - 37 = 43$

Thus, second set = {42, 43, 44, 45, 46} & sum of the above elements = 220.

Option E is the correct answer.

**QNo:- 43 ,Correct Answer:- A**

**Explanation:-**

$$\text{Train fare for one person} = \frac{3}{4} \times (420 + 420) = \text{Rs. } 630$$

$$\therefore \text{Total fare as required} = 2 \times 420 + 4 \times 630 = 840 + 2520 = \text{Rs. } 3360/-$$

Hence, option A is the correct answer.

**QNo:- 44 ,Correct Answer:- D**

**Explanation:-**

$$\text{Speed of tractor} = 360/12 = 30 \text{ km/hr}$$

$$\text{Speed of jeep} = (250/100) \times 30 = 75 \text{ km/hr}$$

Also, ratio of the speeds of a car, a jeep and a tractor is given to be 3:5:2

$$\text{Hence, speed of car} = 45 \text{ km/hr}$$

But since the distance travelled or time taken by car and jeep is not given, the average speed can not be determined.

Hence, option D is the correct answer.

**QNo:- 45 ,Correct Answer:- B**

**Explanation:-**

Suppose each boarder pays Rs.  $X$ . Then the total expenses are  $30X$ . If the number of boarders increases by 10, each one would pay Rs.  $(X - 2)$ . In this case, the total expenses are  $40(X - 2)$ . From the given information,  $40(X - 2) = 30X + 40$ . Solving this equation yields  $30X = \text{Rs. } 360$ .

**QNo:- 46 ,Correct Answer:- A**

**Explanation:-**

Using the units of work approach we can say that A does 40 units of work per day and B does 30 units of work per day.

The ratio of their payment will be in the ratio of their work i.e.  $40 : 30$  or  $4 : 3$ .

Since the total payment is 2,100, B's share will be  $\frac{3}{4+3} \times 2100$

= Rs 900

So option A.

**QNo:- 47 ,Correct Answer:- C**

**Explanation:-**

This can be solved using alligation.

What is required at the end of mixing is a price of  $20/1.25 = 16$ .

So the alligation would look like this –

Water	Mixture	Chemical
-------	---------	----------

0	16	25
---	----	----

Hence the ratio would be  $(25 - 16) : 16 = 9 : 16$

Hence required ratio of Water : Chemical is

9:16.

Hence option C.

**QNo:- 48 ,Correct Answer:- A**

**Explanation:-**

If all of them are boys then total amount should be =Rs 1000

If all of them are girls then total amount should be =Rs 1500

So

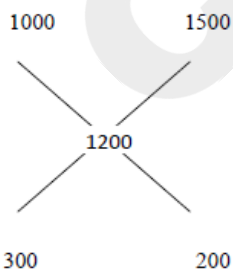

So ratio 3:2

Hence no. of girls =  $\frac{2}{5} \times 100 = 40$

Hence, option A is the correct answer.

**QNo:- 49 ,Correct Answer:- D**

**Explanation:-**

In Statement I: We have  $y - x = 0 \Rightarrow x = y$ . Put it in  $(2xy)^{1/2}$ , we get  $\sqrt{2}x$  which is not an integer. So Statement I is sufficient to answer the question.

Statement II: Here we have  $xy = 1$ , so the given expression becomes  $(2)^{1/2}$ , which is not an integer. Hence statement II is also sufficient to answer the question.

**QNo:- 50 ,Correct Answer:- C**

**Explanation:-**

$$\text{Total saving} = 1+2+3 + \dots + 30+31 = \Sigma 31 = \frac{31 \times 32}{2} = 496$$

**QNo:- 51 ,Correct Answer:- E**

**Explanation:-**

$$\text{If } x \text{ is the cost price then, we have } = x + \frac{14}{100} \times x = 250$$

$$\Rightarrow \frac{114}{100} x = 250 \Rightarrow x = \text{Rs. } 219.2 \sim \text{Rs. } 219$$

Therefore, profit earned per calculator =  $250 - 219 = \text{Rs. } 31$

In 19 days, by selling 7 calculators per day, profit earned =  $19 \times 7 \times 31 = \text{Rs. } 4123$

So none of these is the answer

**QNo:- 52 ,Correct Answer:- A**

**Explanation:-**

Interest earned in 1996

$$= (30 \text{ lacs} + 25 \text{ lacs}) \times \frac{14}{100} = 7.7 \text{ lacs}$$

Interest earned in 1997

$$= (30 \text{ lacs} + 25 \text{ lacs} + 40 \text{ lacs}) \times \frac{12}{100} = 11.4 \text{ lacs}$$

$$\text{Difference} = 11.4 - 7.7 = 3.7 \text{ lacs}$$

**QNo:- 53 ,Correct Answer:- D**

**Explanation:-**

Earnings for 1998:

$$(25 \text{ lacs} + 40 \text{ lacs} + 22 \text{ lacs}) \times \frac{12}{100} = 10.44 \text{ lacs}$$

Earnings for 1999:

$$(40 \text{ lacs} + 22 \text{ lacs} + 20 \text{ lacs}) \times \frac{12}{100} = 9.84 \text{ lacs}$$

Total earnings = adding both = 20.28 lacs.

**QNo:- 54 ,Correct Answer:- A**

**Explanation:-**

Earning for 2000

$$= (22 \text{ lacs} + 20 \text{ lacs} + 27.5 \text{ lacs} + 40 \text{ lacs})$$

$$= 109.5 \text{ lacs} \times \frac{14}{100} = 15.33 \text{ lacs}$$

$$\text{Interest for 1997} = 40 \times \frac{1}{100} = 0.4 \text{ lacs}$$

Total earnings =  $15.33 + 0.4 = 15.73 \text{ lacs}$ . So answer is 1<sup>st</sup> option.

**QNo:- 55 ,Correct Answer:- A**

**Explanation:-**

The only difference is of 20 lacs in 1997.

$$\text{So difference will be } 20 \times \frac{12}{100} = 2.4 \text{ lacs}$$

**QNo:- 56 ,Correct Answer:- B**

**Explanation:-**

The amount lent out in 1999 is 20 lacs and the amount lent out in 1997 is 40 lacs

The difference in the interest will be

$$\begin{aligned} & (40 \times \frac{12}{100} - 20 \times \frac{12.5}{100}) \\ & = 4.8 - 2.5 = 2.3 \text{ lacs.} \end{aligned}$$

**QNo:- 57 ,Correct Answer:- E**

**Explanation:-**

PRODUCT	Total number of Products	Quality A	Quality B
Fans	$1/5 * 500 = 100$	65	35
AC	15% of 500 = 75	50	25
Refrigerators	25% of 500 = 125	85	40
Ovens	$500 - (100 + 75 + 125) = 200$	180	20

Required number = 25 + 20 + 65 + 85 = 195

Hence, option E is the correct answer.

**QNo:- 58 ,Correct Answer:- D**

**Explanation:-**

PRODUCT	Total number of Products	Quality A	Quality B
Fans	$1/5 * 500 = 100$	65	35
AC	15% of 500 = 75	50	25
Refrigerators	25% of 500 = 125	85	40
Ovens	$500 - (100 + 75 + 125) = 200$	180	20

Average number of quality A products

$$= \frac{65 + 50 + 85 + 180}{4} = \frac{380}{4} = 95$$

Hence, option D is the correct answer.

**QNo:- 59 ,Correct Answer:- B**

**Explanation:-**

PRODUCT	Total number of Products	Quality A	Quality B
Fans	$1/5 \times 500 = 100$	65	35
AC	$15\% \text{ of } 500 = 75$	50	25
Refrigerators	$25\% \text{ of } 500 = 125$	85	40
Ovens	$500 - (100 + 75 + 125) = 200$	180	20

Required ratio =  $20 : 65 = 4 : 13$

Hence, option B is the correct answer.

**QNo:- 60 ,Correct Answer:- A**

**Explanation:-**

PRODUCT	Total number of Products	Quality A	Quality B
Fans	$1/5 \times 500 = 100$	65	35
AC	$15\% \text{ of } 500 = 75$	50	25
Refrigerators	$25\% \text{ of } 500 = 125$	85	40
Ovens	$500 - (100 + 75 + 125) = 200$	180	20

Required difference =  $50 - 25 = 25$

Hence, option A is the correct answer.

**QNo:- 61 ,Correct Answer:- D**

**Explanation:-**

PRODUCT	Total number of Products	Quality A	Quality B
Fans	$1/5 \times 500 = 100$	65	35
AC	$15\% \text{ of } 500 = 75$	50	25
Refrigerators	$25\% \text{ of } 500 = 125$	85	40
Ovens	$500 - (100 + 75 + 125) = 200$	180	20

Required percentage =  $\frac{85}{200} \times 100 = 42.5\%$

Hence, closest answer is option D.

**QNo:- 62 ,Correct Answer:- A**

**Explanation:-**

For tablet => 14% of 21000 = 2940

Number of owners of tablets who read e-books on the tablet daily or almost every day  
=  $25/100 \times 2,940 = 735$

Number of owners of tablets who read e-books less often on a tablet =  $15/100 \times 2,940 = 441$

Therefore, required difference =  $735 - 441 = 294$

The correct answer is option 1.

**QNo:- 63 ,Correct Answer:- A**

**Explanation:-**

Number of people who own cell phone =  $36/100 \times 21,000 = 7,560$

Number of people who own desktop/laptop =  $35/100 \times 21,000 = 7,350$

Number of people who own e-book reader =  $15/100 \times 21,000 = 3,150$

Number of people who own tablet =  $14/100 \times 21,000 = 2,940$

Number of cell phone owners who read e-books few times a month  
=  $10/100 \times 7,560 = 756$

Number of e-book reader owners who read e-books few times a month  
=  $20/100 \times 3,150 = 630$

Number of tablet owners who read e-books few times a month  
=  $20/100 \times 2,940 = 588$

Number of desktop/laptop owners who read e-books few times a month  
=  $10/100 \times 7,350 = 735$

Total number of people who read e-books few times a month on the device they own  
=  $756 + 630 + 588 + 735 = 2,709$

Number of people who use tablet to read e-books few times a month = 588

Required percentage =  $588/2,709 \times 100 = 21.71\%$  (approx.)

The correct answer is option 1.

**QNo:- 64 ,Correct Answer:- C**

**Explanation:-**

Total number of people who read e-books 'less often' on cell phones, e-book readers and tablets =  $378 + 315 + 441 = 1,134$

Therefore, Number of people who read e-books on these three devices only once a year

=  $2/3 \times 1,134 = 756$ . The correct answer is option 3.

**QNo:- 65 ,Correct Answer:- E**

**Explanation:-**

Length of bus / Speed of Man = 8, Length of bus / Speed of Bus = 4, Dividing both we get Speed of bus / Speed of Man =  $8/4 = 2$  : 1. As this is not given in any of the options, the answer will be none of these.

**QNo:- 66 ,Correct Answer:- C**

**Explanation:-**

Total Cost =  $15 \times 5 + 4 \times 50 + 6 \times 75 + 5 \times 20 = 825$

**QNo:- 67 ,Correct Answer:- C**

**Explanation:-**

Area of square = (side)<sup>2</sup> = 196 , side = 14cm . Radius of the larger circle = 14 \*2 = 28cm

Radius of the smaller circle(r) = 3/7 × 28 = 12

Circumference of the smaller circle = 2πr = 24πcm.

**QNo:- 68 ,Correct Answer:- B**

**Explanation:-**

Let the angles be 3x, 4x, 6x, 7x . Sum of angles in a quadrilateral = 360

3x + 4x + 6x + 7x = 360, x = 18.

Angles are 54 , 72 , 108 , 126.

Second largest angle = 108 , half of this = 54 = smaller angle of parallelogram

Sum of two adjacent angles in a parallelogram = 180 degree.

Adjacent angle = 180 – 54 = 126 degree

**QNo:- 69 ,Correct Answer:- C**

**Explanation:-**

Statement: let the terms be A, B, C.

A = term 1

B = term 2

C = term 3

Statement1:

C=4----(1)

It doesn't help in getting the value of A

Statement2:

B=3 × A-----(2)

C=4 × B-----(3)

Which also doesn't give us any idea about the value of A

Using both

Put the value of C = 4 in (3)

Get the value of B

Put the value of B in (2)

Get the value of A

**QNo:- 70 ,Correct Answer:- D**

**Explanation:-**

Though the relative speed of B, C, & D can be known from I & II, nothing is known about A. Hence data is not sufficient to solve the problem.

**QNo:- 71 ,Correct Answer:- B**

$$\frac{\log(97 - 56\sqrt{3})}{\log\sqrt{7 + 4\sqrt{3}}} = \frac{\log(49 + 48 - 56\sqrt{3})}{\log(7 + 4\sqrt{3})^{1/2}} = \frac{\log(7 - 4\sqrt{3})^2}{\frac{1}{2}\log(7 + 4\sqrt{3})} = 4 \frac{\log(7 - 4\sqrt{3})}{\log(7 + 4\sqrt{3})}$$

$$\text{Also, } \log(7 - 4\sqrt{3}) = \log\left(\frac{(7 - 4\sqrt{3})(7 + 4\sqrt{3})}{(7 + 4\sqrt{3})}\right) = \log\frac{49 - 48}{7 + 4\sqrt{3}} = \log(7 + 4\sqrt{3})^{-1} = -\log(7 + 4\sqrt{3})$$

$$\text{Substituting, } 4 \frac{-\log(7 + 4\sqrt{3})}{\log(7 + 4\sqrt{3})} = -4$$

**Explanation:-**

**QNo:- 72 ,Correct Answer:- A**

**Explanation:-** In word CANDIDATE, vowels are AIAE

Considering all vowels together as one letter .

Total number of arrangements =  $(6 ! / 2!) * (4 ! / 2 ! ) = 4320$

**QNo:- 73 ,Correct Answer:- B**

**Explanation:-**

There are 3 letters between C & G and G & K while 5 letters are there between K & Q and Q & W. The same pattern has been followed in BFJPV and DHLRX.

**QNo:- 74 ,Correct Answer:- B**

**Explanation:-**

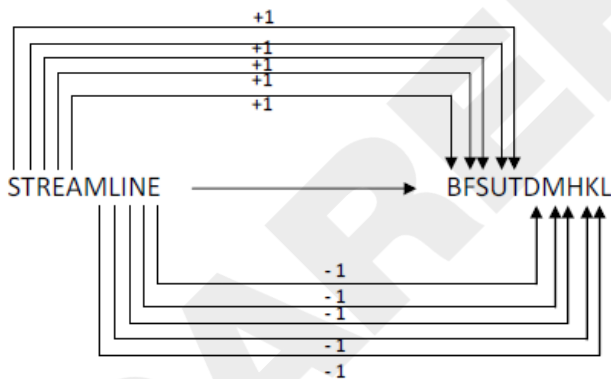

Similarly

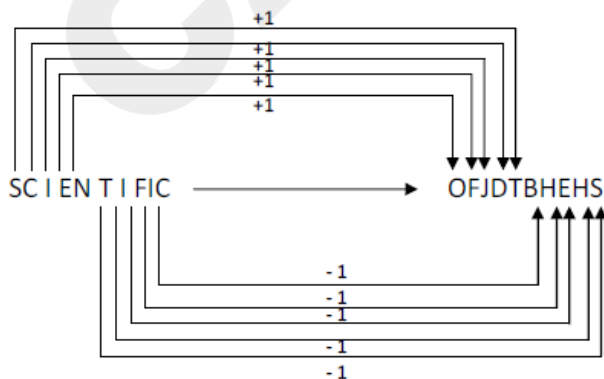

Hence option B

**QNo:- 75 ,Correct Answer:- E**

**Explanation:-**

The series is JKLM where odd positioned letters & even positioned letters are together. Since, none of the options represents the similar pattern so answer is option E.

There can be also another explanation for this question. In JL there is a gap of one alphabet in between that is K. Similarly in KM there is a gap of one alphabet in between that is L. Since no option follows the pattern. Hence, option E is the correct answer.

**QNo:- 76 ,Correct Answer:- D**

**Explanation:-**

Except 217 all are prime numbers.

**QNo:- 77 ,Correct Answer:- A**

**Explanation:-**

The sequence consists of two series

C, D, E, F, G and B, A, Z, Y, X

The missing letter is Y.

**QNo:- 78 ,Correct Answer:- B**

**Explanation:-**

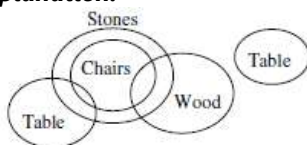

Two different locations are possible for the tables. Conclusion I may or may not be correct but conclusion II is surely true.

**QNo:- 79 ,Correct Answer:- E**

**Explanation:-**

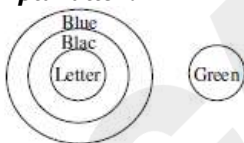

Only I diagram is possible for the statements given. So both of the conclusions are true.

**QNo:- 80 ,Correct Answer:- C**

**Explanation:-**

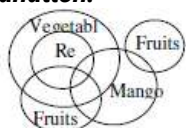

There are 2 possible ways to make diagram according to given statements. Some fruits may be red or may not be red. Thus, either conclusion I or II has to be true.

**QNo:- 81 ,Correct Answer:- E**

**Explanation:-**

Sno.	Name	Team, Place	Jersey	Features
1,2	David Disouza	AP	31	31pt Shooter
2,1	Ramesh Nayudu/Subhash Divyundu	AP	2/3(1 digit)	Passer
3	Subhash Divyundu/Jayesh Patel	Gujrat	40/34	
4		Gujrat	34/40	Heaviest
5		MP	2digit	
6		UP	2/3(1 digit)	
7		Maharashtra	(2 digit)	
8	Rahul Jha	WB	(2 digit)	Drunker

*Rahul Jha can't be at second position as he was interviewed after Ramesh Nayudu and the eldest player played for Bihar so he can not be at second position*

**QNo:- 82 ,Correct Answer:- E**

Sno.	Name	Team, Place	Jersey	Features
1,2	David Disouza	AP	31	31pt Shooter
2,1	Ramesh Nayudu/Subhash Divyundu	AP	2/3(1 digit)	Passer
3	Subhash Divyundu/Jayesh Patel	Gujrat	40/34	
4		Gujrat	34/40	Heaviest
5		MP	2digit	
6		UP	2/3(1 digit)	
7		Maharashtra	(2 digit)	
8	Rahul Jha	WB	(2 digit)	Drunker

**Explanation:-**

*Akshay Kumar will be the answer  
Option E*

**QNo:- 83 ,Correct Answer:- D**

**Explanation:-**

Sno.	Name	Team, Place	Jersey	Features
1,2	David Disouza	AP	31	31pt Shooter
2,1	Ramesh Nayudu/Subhash Divyundu	AP	2/3(1 digit)	Passer
3	Subhash Divyundu/Jayesh Patel	Gujrat	40/34	
4		Gujrat	34/40	Heaviest
5		MP	2digit	
6		UP	2/3(1 digit)	
7		Maharashtra	(2 digit)	
8	Rahul Jha	WB	(2 digit)	Drunker

**QNo:- 84 ,Correct Answer:- D**

**Explanation:-**

From the given information, we know that G and D must be in the same pen and A and B must be in separate pens. So, G, D and A could be in one pen while B, C, E and F will be in the other pen, or G, D and B can be in one pen while A, C, E and F will be in the other pen.

**QNo:- 85 ,Correct Answer:- B**

**Explanation:-**

The arrangements are as follows:

Pen 1 – (A, E, F) and Pen 2 – (B, C, D, G)

Pen 1 – (B, E, F) and Pen 2 – (A, C, D, G)

Pen 1 – (B, D, G) and Pen 2 – (A, C, E, F)

Pen 1 – (A, D, G) and Pen 2 – (B, C, E, F)

In all these cases, C is in pen 2.

**QNo:- 86 ,Correct Answer:- E**

**Explanation:-**

The arrangements are as follows:

Pen 1 – (A, C, E) and Pen 2 – (B, D, F, G)

Pen 1 – (B, C, E) and Pen 2 – (A, D, F, G)

Pen 1 – (A, C, F) and Pen 2 – (B, D, E, G)

Pen 1 – (B, C, F) and Pen 2 – (A, D, E, G)

From this we see that C is either in the same pen as F or in a lower numbered pen than F.

**QNo:- 87 ,Correct Answer:- C**

**Explanation:-**

The commuters are losing their time and money and the poor condition of roads can also lead to accidents. Therefore statement D is the effect of bad roads.

*Option A cannot be the answer as it does not tell you the effect but state of roads in urban areas*

*Option B informs about the cause of roads being constructed with materials of inferior quality*

*Option C is quite generic in nature*

*Option F informs about the measures that have been taken in order to improve the conditions of poorly constructed roads thereby cannot be considered as an answer.*

**QNo:- 88 ,Correct Answer:- D**

**Explanation:-**

As the rural areas are not connected to major cities they face difficulty in getting access to market and hence do not contribute to their full potential to the economy and also due to poor roads valuable economic time as well as fuel is wasted affecting economy adversely.

Option A cannot be the answer as it does not tell you the effect but state of roads in urban areas.

Option B informs about the cause of roads being constructed with materials of inferior quality

Option E informs about the measures that have been taken in order to improve the conditions of poorly constructed roads thereby cannot be considered as an answer.

**QNo:- 89 ,Correct Answer:- B**

**Explanation:-**

Due to poor planning often the roads are constructed using inferior quality material and just before the onset of rains and hence develop potholes.

*Statement A cannot be the answer as it does not tell you the effect but state of roads in urban areas.*

*Statement C is quite generic in nature*

*Statement D contains the effect of the roads built with poor material.*

*Statement E informs about the measures that have been taken in order to improve the conditions of poorly constructed roads thereby cannot be considered as an answer.*

**QNo:- 90 ,Correct Answer:- A**

**Explanation:-**

Statement F is the solution.

**QNo:- 91 ,Correct Answer:- A**

**Explanation:-**

Option 2 cannot be considered as allowing investment from other countries may also stand a chance to boost economy as it could ease supply side pressures and mitigate inflation and benefit, especially, the small and medium enterprises by way of greater market access and higher profit margins.

Option 3 has got no firm basis as to what is the original intent of foreign countries.

Option 4 cannot be the answer as on the contrary customer satisfaction in Indian banking industry is quite dependednt on modern technology adopted through FDI so it will more likely see an encouragement rather than suffering from any crisis.

Option 5 is absolutely vague.

Therefore Option 1 is the most suitable alternative as Foreign retailers' investment in back-end infrastructure needs development and maintenance requirements thus in turn will require man power to employ.

**QNo:- 92 ,Correct Answer:- C**

**Explanation:-**

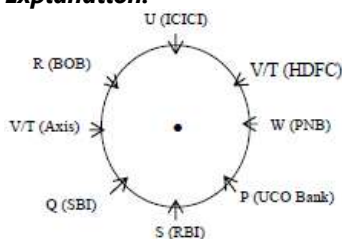

R works with BOB.Hence option C is the answer.

**QNo:- 93 ,Correct Answer:- E**

**Explanation:-**

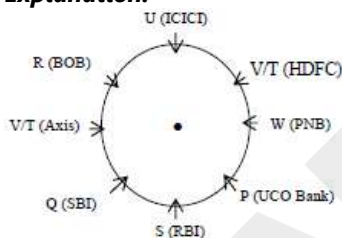

Only 1 person is between R and Q anticlockwise.Hence option E is the answer.

**QNo:- 94 ,Correct Answer:- D**

**Explanation:-**

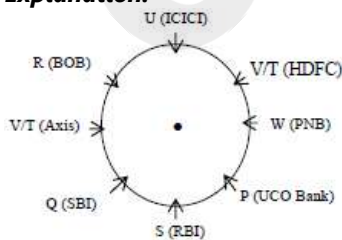

Either V or T works with HDFC.Hence option D is the answer.

**QNo:- 95 ,Correct Answer:- E**

**Explanation:-**

The pattern used for converting Input to final step is: Number along with adjacent word are arranged in increasing order and the remaining words are arranged in reverse dictionary order.

Input : any number less than 30 and more than 20 does not equal 40.

Step I : than 20 any number less than 30 and more does not equal 40.

Step II : than 20 than 30 any number less and more does not equal 40.

Step III : than 20 than 30 equal 40 any number less and more does not.

Step IV : than 20 than 30 equal 40 number any less and more does not.

Step V : than 20 than 30 equal 40 number not any less and more does.

Step VI : than 20 than 30 equal 40 number not more any less and does.

Step VII : than 20 than 30 equal 40 number not more less any and does.

Step VIII : than 20 than 30 equal 40 number not more less does any and.

The given output is at step I.

**QNo:- 96 ,Correct Answer:- B**

**Explanation:-**

The pattern used for converting Input to final step is: Number along with adjacent word are arranged in increasing order and the remaining words are arranged in reverse dictionary order.

Input : any number less than 30 and more than 20 does not equal 40.

Step I : than 20 any number less than 30 and more does not equal 40.

Step II : than 20 than 30 any number less and more does not equal 40.

Step III : than 20 than 30 equal 40 any number less and more does not.

Step IV : than 20 than 30 equal 40 number any less and more does not.

Step V : than 20 than 30 equal 40 number not any less and more does.

Step VI : than 20 than 30 equal 40 number not more any less and does.

Step VII : than 20 than 30 equal 40 number not more less any and does.

Step VIII : than 20 than 30 equal 40 number not more less does any and.

Thus 8 steps are required, hence the answer will be second option.

**QNo:- 97 ,Correct Answer:- E**

**Explanation:-**

The pattern used for converting Input to final step is: Number along with adjacent word are arranged in increasing order and the remaining words are arranged in reverse dictionary order.

Input : any number less than 30 and more than 20 does not equal 40.

Step I : than 20 any number less than 30 and more does not equal 40.

Step II : than 20 than 30 any number less and more does not equal 40.

Step III : than 20 than 30 equal 40 any number less and more does not.

Step IV : than 20 than 30 equal 40 number any less and more does not.

Step V : than 20 than 30 equal 40 number not any less and more does.

Step VI : than 20 than 30 equal 40 number not more any less and does.

Step VII : than 20 than 30 equal 40 number not more less any and does.

Step VIII : than 20 than 30 equal 40 number not more less does any and.

It can be seen that no step has the arrangement in the same order as given in the question, hence the answer will be none of these.

**QNo:- 98 ,Correct Answer:- C**

**Explanation:-**

The pattern used for converting Input to final step is: Number along with adjacent word are arranged in increasing order and the remaining words are arranged in reverse dictionary order.

Input : any number less than 30 and more than 20 does not equal 40.

Step I : than 20 any number less than 30 and more does not equal 40.

**Step II : than 20 than 30 any number less and more does not equal 40.**

Step III : than 20 than 30 equal 40 any number less and more does not.

Step IV : than 20 than 30 equal 40 number any less and more does not.

Step V : than 20 than 30 equal 40 number not any less and more does.

Step VI : than 20 than 30 equal 40 number not more any less and does.

Step VII : than 20 than 30 equal 40 number not more less any and does.

Step VIII : than 20 than 30 equal 40 number not more less does any and.

Step II - given in the third option is the answer.

**QNo:- 99 ,Correct Answer:- C**

**Explanation:-**

The pattern used for converting Input to final step is: Number along with adjacent word are arranged in increasing order and the remaining words are arranged in reverse dictionary order.

Input : any number less than 30 and more than 20 does not equal 40.

Step I : than 20 any number less than 30 and more does not equal 40.

Step II : than 20 than 30 any number less and more does not equal 40.

Step III : than 20 than 30 equal 40 any number less and more does not.

Step IV : than 20 than 30 equal 40 number any less and more does not.

Step V : than 20 than 30 equal **40** number not any less and more does.

Step VI : than 20 than 30 equal 40 number not more any less and does.

Step VII : than 20 than 30 equal 40 number not more less any and does.

Step VIII : than 20 than 30 equal 40 number not more less does any and.

Hence 40 i.e. the third option is the answer.

**QNo:- 100 ,Correct Answer:- B**

**Explanation:-**

Differences between consecutive terms are -1, 4, -27, 16 which further can be written as  $(-1)^3, 2^2, (-3)^3, 4^2$  & so on. Thus, next difference will be  $(-5)^3$  to be added in the last given term. Doing that the answer will be  $202 - 125 = 77$ .

Hence, option B is the correct answer.

**QNo:- 101 ,Correct Answer:- E**

**Explanation:-**

$$467 - 444 = 23 = 23 \times 1$$

$$513 - 467 = 46 = 23 \times 2$$

$$582 - 513 = 69 = 23 \times 3$$

$$674 - 582 = 92 = 23 \times 4$$

$$789 - 674 = 115 = 23 \times 5$$

$$? = 789 + 23 \times 6 = 789 + 138 = 927.$$

Hence option E.

**QNo:- 102 ,Correct Answer:- E**

**Explanation:-**

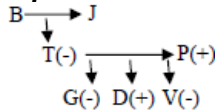

So as per the above diagram nothing is clear about B and J.  
So option 5.

**QNo:- 103 ,Correct Answer:- A**

**Explanation:-**

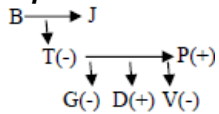

Clearly V is the daughter of P. So option 1.

**QNo:- 104 ,Correct Answer:- A**

**Explanation:-** Option C that 'Photography is rarely a true representation of reality, is completely false as per the passage. Option B is incorrect too as the passage does not support the misrepresentation of the photographs. Option E is far fetched. Between options A and D, A is the best answer.

**QNo:- 105 ,Correct Answer:- A**

**Explanation:-**

As the parents are not ready to pay the extra fee for remedial classes, they are thinking of changing the school of their children.

**QNo:- 106 ,Correct Answer:- B**

**Explanation:-**

Beth won the gold (stood first) and also has an experience of competing 7 times, the highest of all.

**QNo:- 107 ,Correct Answer:- D**

**Explanation:-**

After the switching is done, following is the schedule.

Ms. Johnson - Wednesday, Mr. Carter – Mon, Ms. Falk – Thursday, Mr. Kirk – Tuesday.

**QNo:- 108 ,Correct Answer:- E**

**Explanation:-**

Given the gravity of problem both course of actions should follow.

# Other Useful Resources

---

Are you preparing for the NMAT 2023 examination, a pivotal milestone on your journey toward your desired MBA program? Achieving success in this fiercely competitive examination necessitates more than just unwavering commitment and diligence; it also hinges upon having unfettered access to top-tier study resources. To facilitate your triumph in the NMAT 2023 examination, we have meticulously assembled a collection of indispensable eBooks and video lectures that comprehensively address key subject matter and furnish expert solutions. Let us delve into these invaluable resources:

## 3000+ Most Important Words - Vocabulary Builder

Elevate your proficiency in Language Comprehension by acquainting yourself with our eBook, housing an extensive lexicon exceeding 3000 essential words. This compendium not only provides word definitions but also delves into antonyms and synonyms, thereby catering to the Language Comprehension component of the NMAT 2023 examination—an element that has assumed even greater significance in the revised examination format.

[DOWNLOAD NOW](#) 

## 500+ Most Important Idioms and Phrases

Fortify your Verbal and Logical Aptitude for the NMAT 2023 examination with our eBook, encompassing a compendium of over 500 idiomatic expressions and phrases, each accompanied by comprehensive elucidations and practical usage illustrations. This resource serves as your clandestine asset for excelling in the Verbal and Logical Aptitude segment.

[DOWNLOAD NOW](#) 

## 300+ Most Important Phrasal Verbs

Achieve mastery in the Verbal and Logical Aptitude section of the NMAT 2023 examination with our eBook, comprising an exhaustive registry of over 300 phrasal verbs, categorized by types and elucidated through illustrative instances and practice queries. Enhance your command over this pivotal subject matter.

[DOWNLOAD NOW](#) 

## Permutation & Combination - Video Lectures and Practice Questions

Secure vital marks in the Quantitative Ability & Data Interpretation component of the NMAT 2023 examination through our video lectures and accompanying problem sets. This resource is meticulously tailored to facilitate your comprehensive understanding of the mathematical concept of Permutation & Combination.

[DOWNLOAD NOW](#) 

## Mastering DILR Questions with Expert Solutions

Attain excellence in the Data Interpretation and Logical Reasoning (DILR) segment of the NMAT 2023 examination with our eBook, replete with expert solutions to DILR queries. Hone your problem-solving prowess and conquer this pivotal segment with unwavering self-assurance.

[DOWNLOAD NOW](#) 

Do not allow this golden opportunity to access these indispensable study materials to elude you. Simply click the “Download Now” button adjacent to each eBook’s description to commence your journey toward

# Computer Based Mock Test

Congratulations on your journey to NMAT success with our comprehensive eBook! As you near your exam date, it's time to take your preparation to the next level. Discover the invaluable role of Mock Tests and why ours are the perfect fit for you.

## The Importance of Mock Tests:

- **Assess Your Readiness:** Mock tests provide a clear snapshot of your current preparedness. They help you identify strengths and areas that need improvement, enabling you to focus your efforts effectively.
- **Hone Time Management:** Time is of the essence in NMAT. Mock tests allow you to practice time management skills, ensuring you can complete all sections within the stipulated time, a crucial aspect of your success.
- **Simulate Real Exam Conditions:** Familiarity breeds confidence. Our mock tests closely mimic the NMAT exam environment, helping you become comfortable with the format, difficulty level, and question types you'll encounter.
- **Benchmark Your Performance:** With our mock tests, you'll receive detailed performance reports, including section-wise analysis. This not only helps you track your

progress but also gives you a competitive edge by showing you where you stand compared to your peers.

## Why Our Mock Tests Shine:

- **Exact NMAT Exam Simulation:** Our mock tests are designed to replicate the NMAT exam experience as closely as possible. When you practice with us, you're essentially rehearsing for the real deal.
- **Comprehensive Section Coverage:** Our tests comprehensively cover all sections of the NMAT exam, ensuring you're well-prepared for every aspect of the test – Quantitative, Verbal, and Logical Reasoning.
- **In-depth Answer Explanations:** We provide detailed explanations for each question, not just revealing the correct answer but also helping you understand the reasoning behind it. This enhances your overall comprehension and problem-solving skills.
- **Real-time Performance Analytics:** Receive instant feedback on your performance after each mock test. Our analytics tools track your progress and areas that require more attention, allowing you to fine-tune your strategy.
- **Adaptive Testing Tailored to You:** Our mock tests adapt to your performance level. If you excel in a specific area, we'll challenge you accordingly, ensuring you make the most efficient use of your study time.

**Ready to Supercharge Your NMAT Prep?**

[Attempt Now →](#)

**Unlock your true potential and seize NMAT success. Don't miss this crucial opportunity to excel – Start Now! Your journey towards NMAT excellence begins with a single click.**