

CAREERS 360
PREPARATION Series

GATE 2025

Engineering Sciences (XE)
Question Paper & Answer Key





General Aptitude

Q.1 – Q.5 Carry ONE mark Each

Q.1	Even though I had planned to go skiing with my friends, I had to _____ at the last moment because of an injury. Select the most appropriate option to complete the above sentence.
(A)	back up
(B)	back of
(C)	back on
(D)	back out
Q.2	The President, along with the Council of Ministers, _____ to visit India next week. Select the most appropriate option to complete the above sentence.
(A)	wish
(B)	wishes
(C)	will wish
(D)	is wishing



Q.3	An electricity utility company charges ₹ 7 per kWh (kilo watt-hour). If a 40-watt desk light is left on for 10 hours each night for 180 days, what would be the cost of energy consumption? If the desk light is on for 2 more hours each night for the 180 days, what would be the percentage-increase in the cost of energy consumption?
(A)	₹ 604.8; 10%
(B)	₹ 504; 20%
(C)	₹ 604.8; 12%
(D)	₹ 720; 15%

GATE 2025

IIT Roorkee

Q.4	In the context of the given figure, which one of the following options correctly represents the entries in the blocks labelled (i), (ii), (iii), and (iv), respectively?																
	<table border="1" style="margin: auto;"> <tr> <td style="text-align: center;">N</td> <td style="text-align: center;">U</td> <td style="text-align: center;">F</td> <td style="text-align: center;">(i)</td> </tr> <tr> <td style="text-align: center;">21</td> <td style="text-align: center;">14</td> <td style="text-align: center;">9</td> <td style="text-align: center;">6</td> </tr> <tr> <td style="text-align: center;">H</td> <td style="text-align: center;">L</td> <td style="text-align: center;">(ii)</td> <td style="text-align: center;">O</td> </tr> <tr> <td style="text-align: center;">12</td> <td style="text-align: center;">(iv)</td> <td style="text-align: center;">15</td> <td style="text-align: center;">(iii)</td> </tr> </table>	N	U	F	(i)	21	14	9	6	H	L	(ii)	O	12	(iv)	15	(iii)
N	U	F	(i)														
21	14	9	6														
H	L	(ii)	O														
12	(iv)	15	(iii)														
(A)	Q, M, 12, and 8																
(B)	K, L, 10 and 14																
(C)	I, J, 10, and 8																
(D)	L, K, 12 and 8																

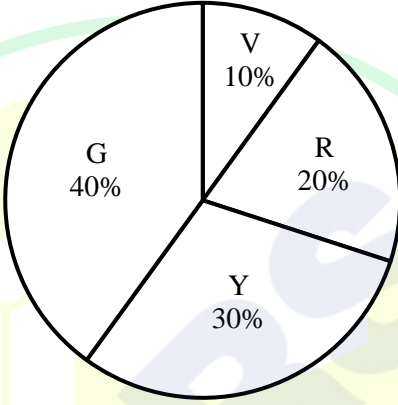
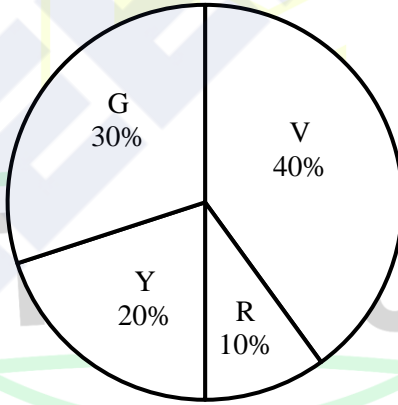
<p>Q.5</p>	<p>A bag contains Violet (V), Yellow (Y), Red (R), and Green (G) balls. On counting them, the following results are obtained:</p> <ul style="list-style-type: none"> (i) The sum of Yellow balls and twice the number of Violet balls is 50. (ii) The sum of Violet and Green balls is 50. (iii) The sum of Yellow and Red balls is 50. (iv) The sum of Violet and twice the number of Red balls is 50. <p>Which one of the following Pie charts correctly represents the balls in the bag?</p>
<p>(A)</p>	 <p>Detailed description of Pie chart (A): A circle is divided into four sectors. The largest sector is labeled 'G' with '40%'. Moving clockwise, the next sector is labeled 'V' with '10%', followed by 'R' with '20%', and the smallest sector is labeled 'Y' with '30%'.</p>
<p>(B)</p>	 <p>Detailed description of Pie chart (B): A circle is divided into four sectors. The largest sector is labeled 'V' with '40%'. Moving clockwise, the next sector is labeled 'R' with '10%', followed by 'Y' with '20%', and the smallest sector is labeled 'G' with '30%'.</p>

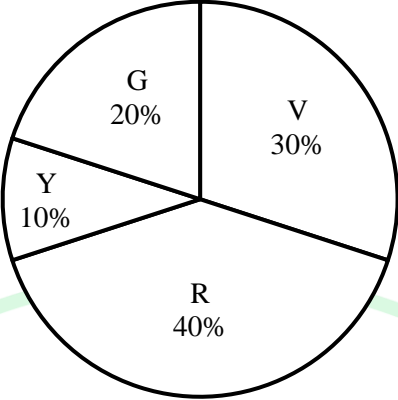
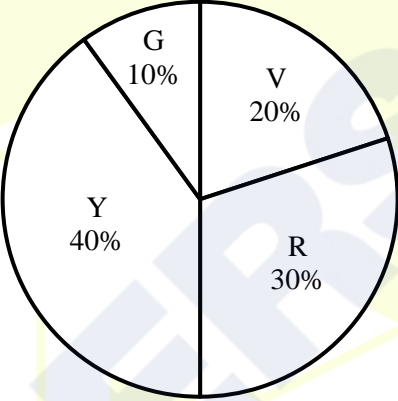
(C)	 <table border="1"><thead><tr><th>Segment</th><th>Percentage</th></tr></thead><tbody><tr><td>G</td><td>20%</td></tr><tr><td>V</td><td>30%</td></tr><tr><td>Y</td><td>10%</td></tr><tr><td>R</td><td>40%</td></tr></tbody></table>	Segment	Percentage	G	20%	V	30%	Y	10%	R	40%
Segment	Percentage										
G	20%										
V	30%										
Y	10%										
R	40%										
(D)	 <table border="1"><thead><tr><th>Segment</th><th>Percentage</th></tr></thead><tbody><tr><td>G</td><td>10%</td></tr><tr><td>V</td><td>20%</td></tr><tr><td>Y</td><td>40%</td></tr><tr><td>R</td><td>30%</td></tr></tbody></table>	Segment	Percentage	G	10%	V	20%	Y	40%	R	30%
Segment	Percentage										
G	10%										
V	20%										
Y	40%										
R	30%										

GATE 2025

IIT Roorkee

Q.6 – Q.10 Carry TWO marks Each

Q.6	<p>“His life was divided between the books, his friends, and long walks. A solitary man, he worked at all hours without much method, and probably courted his fatal illness in this way. To his own name there is not much to show; but such was his liberality that he was continually helping others, and fruits of his erudition are widely scattered, and have gone to increase many a comparative stranger’s reputation.”</p> <p style="text-align: right;">(From E.V. Lucas’s “A Funeral”)</p> <p>Based only on the information provided in the above passage, which one of the following statements is true?</p>
(A)	The solitary man described in the passage is dead.
(B)	Strangers helped create a grand reputation for the solitary man described in the passage.
(C)	The solitary man described in the passage found joy in scattering fruits.
(D)	The solitary man worked in a court where he fell ill.

GATE 2025

IIT Roorkee

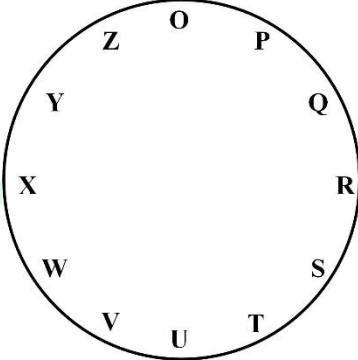
<p>Q.7</p>	<p>For the clock shown in the figure, if</p> <p>$O^* = O Q S Z P R T$, and</p> <p>$X^* = X Z P W Y O Q$,</p> <p>then which one among the given options is most appropriate for P^* ?</p>
	
<p>(A)</p>	<p>P U W R T V X</p>
<p>(B)</p>	<p>P R T O Q S U</p>
<p>(C)</p>	<p>P T V Q S U W</p>
<p>(D)</p>	<p>P S U P R T V</p>

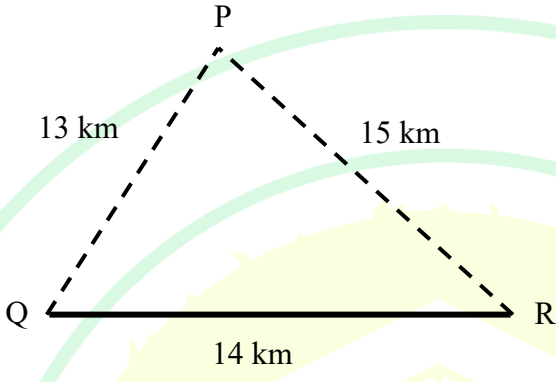

Q.8	<p>Consider a five-digit number $PQRST$ that has distinct digits $P, Q, R, S,$ and $T,$ and satisfies the following conditions:</p> $P < Q$ $S > P > T$ $R < T$ <p>If integers 1 through 5 are used to construct such a number, the value of P is:</p>
(A)	1
(B)	2
(C)	3
(D)	4
Q.9	<p>A business person buys potatoes of two different varieties P and $Q,$ mixes them in a certain ratio and sells them at ₹ 192 per kg.</p> <p>The cost of the variety P is ₹ 800 for 5 kg.</p> <p>The cost of the variety Q is ₹ 800 for 4 kg.</p> <p>If the person gets 8% profit, what is the $P:Q$ ratio (by weight)?</p>
(A)	5:4
(B)	3:4
(C)	3:2
(D)	1:1

<p>Q.10</p>	<p>Three villages P, Q, and R are located in such a way that the distance $PQ = 13$ km, $QR = 14$ km, and $RP = 15$ km, as shown in the figure. A straight road joins Q and R. It is proposed to connect P to this road QR by constructing another road. What is the minimum possible length (in km) of this connecting road?</p> <p>Note: The figure shown is representative.</p>
	
(A)	10.5
(B)	11.0
(C)	12.0
(D)	12.5



Engineering Mathematics (XE-A)

Q.11 – Q.17 Carry ONE mark Each

Q.11	Let X and Y be two random variables with mean 0, variance 1, and correlation coefficient $\frac{1}{3}$. Then the value of $\text{Var}(X + 3Y)$ is equal to
(A)	9
(B)	10
(C)	11
(D)	12

GATE 2025

IIT Roorkee

Q.12	<p>Consider the second order Partial Differential Equation (PDE)</p> $4x^2 \frac{\partial^2 u}{\partial x^2} + 4(x+y) \frac{\partial^2 u}{\partial x \partial y} + (x^2 + y^2) \frac{\partial^2 u}{\partial y^2} - u = 0.$ <p>Then which one of the following statements is correct ?</p>
(A)	<p>The PDE is hyperbolic in the region</p> $\{(x, y) \in \mathbb{R}^2: -1 < x < 0, y < 0\}$
(B)	<p>The PDE is hyperbolic in the region</p> $\{(x, y) \in \mathbb{R}^2: 1 < x < \infty, y < 0\}$
(C)	<p>The PDE is elliptic in the region</p> $\{(x, y) \in \mathbb{R}^2: 0 < x < 1, y > 0\}$
(D)	<p>The PDE is parabolic in the region</p> $\{(x, y) \in \mathbb{R}^2: 1 < x < \infty, y < 0\}$

GATE 2025

IIT Roorkee

<p>Q.13</p>	<p>Consider the infinite series</p> $(P): \sum_{n=2}^{\infty} \frac{1}{(n \log n)^{1/n}}$ $(Q): \sum_{n=1}^{\infty} \frac{n^n}{(2n)!}$ <p>Then which one of the following statements is correct ?</p>
(A)	Series (P) and (Q) both converge
(B)	Series (P) converges and series (Q) diverges
(C)	Series (P) and (Q) both diverge
(D)	Series (P) diverges and series (Q) converges
<p>Q.14</p>	<p>Suppose the polynomial $a + bx + cx^2 + dx^3$ interpolates the data, $(-1, 1)$, $(0, 3)$, $(1, 2)$ and $(2, 4)$. Then which one of the following statements is correct ?</p>
(A)	$a = -2c, d = -2b$
(B)	$a = 2c, d = 2b$
(C)	$b = 3c, a = 2d$
(D)	$b = 2c, a = 3d$

Q.15	<p>Let C be the positively oriented boundary of the domain bounded by the curves $y = 2x^2$ and $y^2 = 4x$. Then the value of the line integral</p> $\oint_C (2y^2 + 2xy + 4y)dx + (x^2 + 4xy + 8x)dy$ <p>is equal to</p>
(A)	$\frac{8}{3}$
(B)	$\frac{2}{3}$
(C)	$\frac{4}{3}$
(D)	$\frac{1}{3}$
Q.16	<p>Let $y(x)$ be the solution of the initial value problem,</p> $x^2y'' + xy' - y = 0, \quad x > 0,$ $y(1) = 0, \quad y'(1) = 2.$ <p>Then the value of $y' \left(\frac{1}{2} \right)$ is equal to (Answer in integer) _____</p>



Q.17	Suppose that 2 is an eigenvalue of the matrix $\begin{bmatrix} 0 & 3 & -\alpha \\ 0 & 1 & 0 \\ 1 & -1 & 3 \end{bmatrix}$ Then the value of α is equal to (Answer in integer) _____

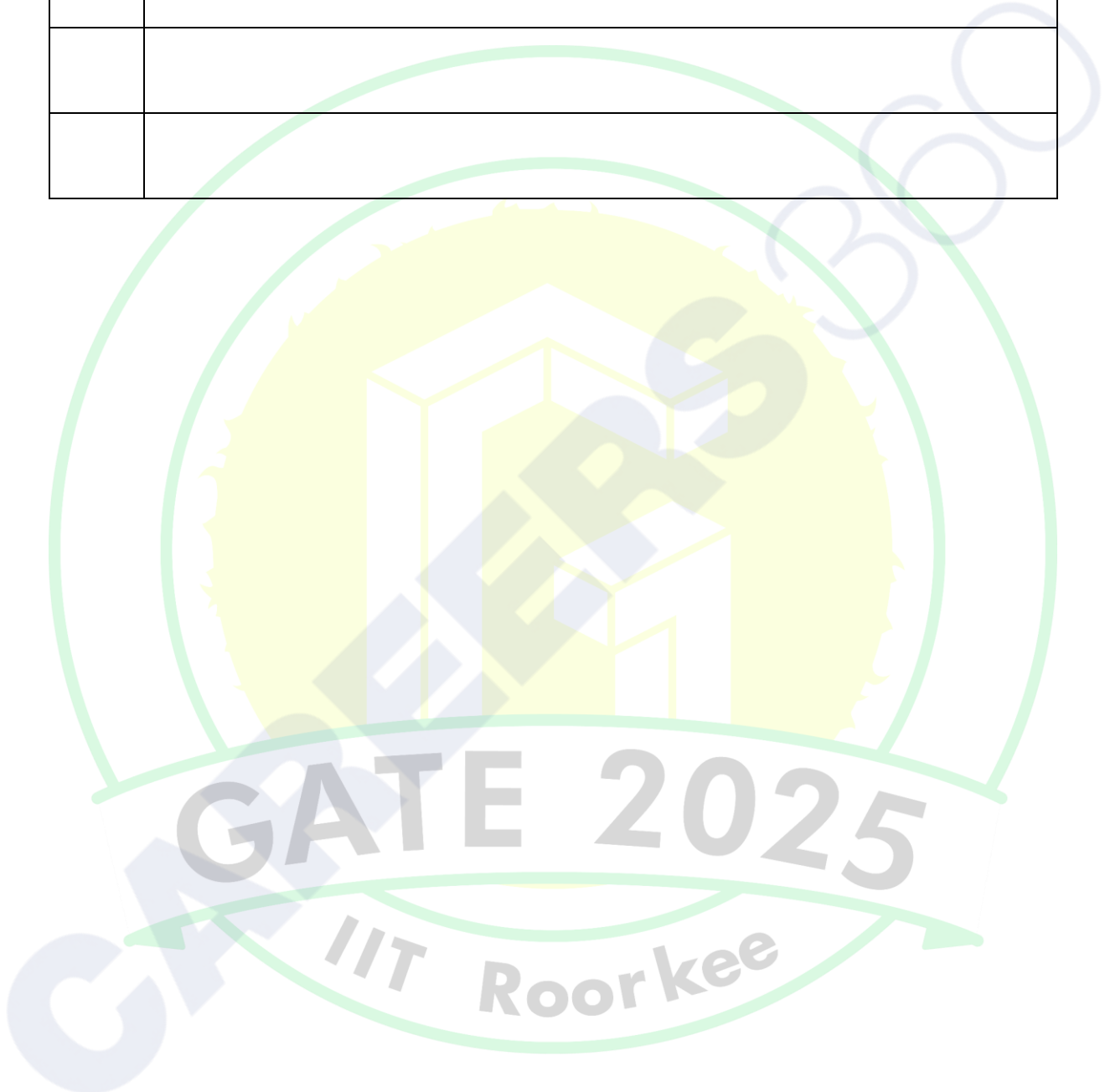

Q.18 – Q.21 Carry TWO marks Each

Q.18	<p>Let $f(z)$ be an analytic function such that</p> $\operatorname{Re}(f'(z)) = 3x^2 - 4y - 3y^2, \quad f(i) = 0, \quad f'(0) = 0,$ <p>where $i = \sqrt{-1}$. Then the value of $f(1)$ is equal to</p>
(A)	$4 + 2i$
(B)	$1 + 5i$
(C)	$1 - i$
(D)	$4 - 2i$
Q.19	<p>Consider the function</p> $f(x, y) = x^2y + 2xy^2 - 2x^2y^2.$ <p>Then which one of the following statements is correct ?</p>
(A)	$\left(\frac{3}{2}, 0\right)$ is a point of local maxima of f .
(B)	$\left(0, \frac{3}{4}\right)$ is a point of local minima of f .
(C)	$\left(\frac{3}{2}, \frac{3}{4}\right)$ is a point of local maxima of f .
(D)	$\left(\frac{3}{2}, \frac{3}{4}\right)$ is a saddle point of f .

<p>Q.20</p>	<p>For $a, b \in \mathbb{R}$, consider the system of linear equations</p> $\begin{aligned}x + y + az &= 2 \\2y + 2z &= 1 \\ax + 2z &= b\end{aligned}$ <p>If the system has infinitely many solutions, then which of the following statements is/are correct ?</p>
<p>(A)</p>	<p>$a = 2, b = 3$</p>
<p>(B)</p>	<p>$a = 2, b = 5$</p>
<p>(C)</p>	<p>$a = -1, b = -\frac{3}{2}$</p>
<p>(D)</p>	<p>$a = 3, b = 5$</p>
<p>Q.21</p>	<p>Let $u(x, t)$ be the solution of the initial boundary value problem</p> $\frac{\partial u}{\partial t} - \frac{\partial^2 u}{\partial x^2} - u = 0, \quad 0 < x < \pi, \quad t > 0,$ $u(x, 0) = 2 \sin\left(\frac{3x}{2}\right) \cos\left(\frac{x}{2}\right), \quad 0 < x < \pi,$ $u(0, t) = u(\pi, t) = 0, \quad t > 0.$ <p>Then the value of $\lim_{t \rightarrow \infty} u\left(\frac{3\pi}{4}, t\right)$ is equal to (rounded off to two decimal places) _____</p>

Fluid Mechanics (XE-B)

Q.22 – Q.30 Carry ONE mark Each

Q.22	<p>Fluid at a constant flow rate passes through a long, straight, cylindrical pipe that has an axisymmetric convergent section at the end.</p> <p>Which one of the following options correctly represents the velocity field in the converging section in cylindrical (r, θ, z) coordinates?</p>
(A)	Two-dimensional function of r and z
(B)	One-dimensional function of r
(C)	Two-dimensional function of r and θ
(D)	One-dimensional function of z
Q.23	<p>A sharp flat plate of length L and infinite width is immersed parallel to a fluid stream having velocity u_∞. At a point on the plate, far away from the leading edge and not near the trailing edge, the boundary layer thickness, the displacement thickness, and the momentum thickness are denoted as δ, δ^*, and θ, respectively.</p> <p>Which one of the following options correctly represents the relation between these thicknesses?</p>
(A)	$\delta > \delta^* > \theta$
(B)	$\delta > \theta > \delta^*$
(C)	$\delta^* > \delta > \theta$
(D)	$\theta > \delta^* > \delta$

Q.24	<p>Consider the following Statements [1] and [2].</p> <p>Statement [1]: The Eulerian study focusses attention on individual particle and its motion is observed as a function of time.</p> <p>Statement [2]: The Lagrangian study focusses attention on the motion of the particles passing through an identified point.</p> <p>Which one of the following options identifies the correctness of the given statements?</p>
(A)	Both [1] and [2] are correct.
(B)	Both [1] and [2] are NOT correct.
(C)	[1] is correct, but [2] is NOT correct.
(D)	[1] is NOT correct, but [2] is correct.

GATE 2025
IIT Roorkee

Q.25	<p>Statement of Reynolds Transport Theorem is given below with three blanks.</p> <p>The rate of change of _____ extensive property can be calculated by summing the rate of change of the amount of same property in the _____ and the rate at which the property is _____ the surface of the control volume.</p> <p>Which one of the following options correctly fills the blanks by using its comma-separated phrases in sequence?</p>
(A)	system, control volume, exiting
(B)	control volume, system, exiting
(C)	system, control volume, entering
(D)	control volume, control volume, entering
Q.26	<p>For a steady and incompressible flow, the velocity field (\vec{V}) in Cartesian (x, y, z) coordinate system is given as:</p> $\vec{V} = 5xi - Pyj + 3k$ <p>Here, i, j, and k are unit vectors along x, y, and z directions, respectively and P is a constant.</p> <p>Which one of the following options is the correct value of P that satisfies the conservation of mass for the given velocity field?</p>
(A)	5
(B)	-5
(C)	8
(D)	2

Q.27	<p>Conservation of mass for a steady axisymmetric flow field in the cylindrical (r, z) coordinates is:</p> $\frac{1}{r} \frac{\partial(rV_r)}{\partial r} + \frac{\partial V_z}{\partial z} = 0$ <p>Here, V_r and V_z are radial and axial components of velocity, respectively.</p> <p>Which one of the following options is correct if ψ is the stream function?</p>
(A)	$V_r = \frac{\partial \psi}{\partial z}$ and $V_z = -\frac{1}{r} \frac{\partial \psi}{\partial r}$
(B)	$V_r = \frac{1}{r} \frac{\partial \psi}{\partial z}$ and $V_z = -\frac{1}{r} \frac{\partial \psi}{\partial r}$
(C)	$V_r = \frac{1}{r} \frac{\partial \psi}{\partial z}$ and $V_z = \frac{1}{r} \frac{\partial \psi}{\partial r}$
(D)	$V_r = \frac{1}{r} \frac{\partial \psi}{\partial z}$ and $V_z = -\frac{\partial \psi}{\partial r}$

GATE 2025

IIT Roorkee

Q.28

Group-I indicates different properties of fluid and **Group-II** defines their basic dimensions in terms of Force (F), Length (L), and Time (T).

	Group-I		Group-II
P	Dynamic viscosity	1	$FL^{-4}T^2$
Q	Surface tension	2	$FL^{-2}T$
R	Density	3	FL^{-1}

Which one of the following options identifies the correct match between **Group-I** and **Group-II**?

(A) P-1, Q-3, R-2

(B) P-2, Q-1, R-3

(C) P-3, Q-2, R-1

(D) P-2, Q-3, R-1

GATE 2025

IIT Roorkee

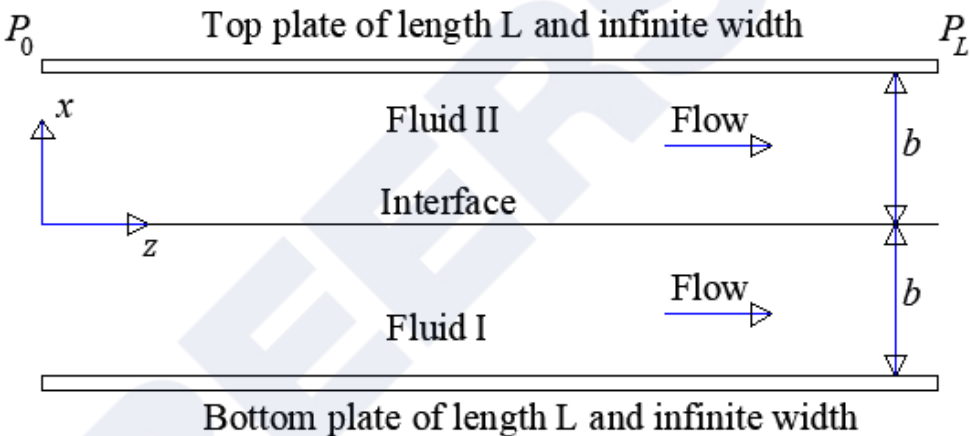

<p>Q.29</p>	<p>Consider the steady, incompressible, and fully developed laminar flow of a fluid through a circular pipe. Here, ΔP is the pressure drop in the direction of the flow and V is the average axial velocity of the fluid at any cross-section. The relation between ΔP and V is:</p> $\Delta P = K V^n$ <p>Here, K and n are constants.</p> <p>Which one of the following options is the correct value of n?</p>
<p>(A)</p>	<p>1</p>
<p>(B)</p>	<p>2</p>
<p>(C)</p>	<p>1.75</p>
<p>(D)</p>	<p>0.5</p>
<p>Q.30</p>	<p>A doublet is the resulting flow pattern when a sink and a source of equal strength are brought together.</p> <p>Which one of the following options correctly represents the nature of the product of the strength and the distance between them during approach?</p>
<p>(A)</p>	<p>Remains always constant</p>
<p>(B)</p>	<p>Continuously decreases</p>
<p>(C)</p>	<p>Continuously increases</p>
<p>(D)</p>	<p>First increases and then continuously decreases after reaching a maximum</p>

Q.31 – Q.43 Carry TWO marks Each

<p>Q.31</p>	<p>Figure shows two parallel plates (upper plate at $x = b$ and lower one at $x = -b$) of length L (aligned in z direction) and infinite width (in y direction, normal to the plane of the figure). Two immiscible, incompressible liquids are flowing steadily in the z direction through the thin passage between the plates under the influence of horizontal pressure gradient $(P_0 - P_L)/L$. During the flow, the passage is always half-filled with denser fluid I (viscosity μ^I) at the bottom and rest is occupied by lighter fluid II (viscosity μ^{II}; $\mu^{II} < \mu^I$). Considering exactly planar interface between the fluids and no instabilities in the flow, the shear stress, τ_{xz} is expressed as:</p> $\tau_{xz} = \frac{(P_0 - P_L)b}{L} \left[\left(\frac{x}{b} \right) - \frac{1}{2} \left(\frac{\mu^I - \mu^{II}}{\mu^I + \mu^{II}} \right) \right]$ <p>Which one of the following options correctly identifies the location of the point having maximum velocity of the flow?</p>
	 <p>The diagram shows two horizontal parallel plates. The top plate is labeled 'Top plate of length L and infinite width' and has pressure P_0 on the left and P_L on the right. The bottom plate is labeled 'Bottom plate of length L and infinite width'. The space between the plates is divided into two regions: 'Fluid II' (top) and 'Fluid I' (bottom), separated by a horizontal 'Interface'. The vertical distance from the interface to the top plate is b, and from the interface to the bottom plate is b. Blue arrows labeled 'Flow' indicate the flow direction is along the z-axis. A coordinate system is shown with the x-axis pointing upwards and the z-axis pointing to the right.</p>
<p>(A)</p>	<p>Above the interface</p>
<p>(B)</p>	<p>Below the interface</p>
<p>(C)</p>	<p>At the interface</p>
<p>(D)</p>	<p>At the top plate</p>

Q.32

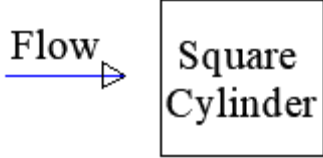
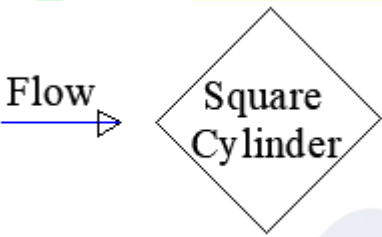
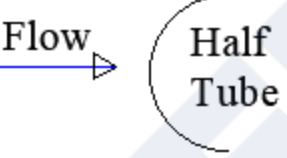
Group-I shows different two-dimensional bodies and **Group-II** mentions their total drag coefficient (C_D) based on frontal area while facing parallel flow of fluid having Reynolds number $Re \geq 10^4$ along the direction of arrow. The bodies are placed symmetrically with respect to the flow direction.

	Group-I		Group-II
P		1	1.2
Q		2	1.6
R		3	2.1
S		4	2.3

Which one of the following options identifies the correct match between **Group-I** and **Group-II**, as per the concept of degree of streamlining?

(A) P-3, Q-2, R-1, S-4

(B) P-3, Q-2, R-4, S-1

(C) P-2, Q-3, R-1, S-4

(D) P-3, Q-1, R-2, S-4

Q.33	<p>A solid body of uniform specific gravity floats in a deep liquid pool. Take B, G, and M as the centre of buoyancy, centre of gravity, and metacentre of the body, respectively.</p> <p>Which one of the following options is correct for the stable floatation of the body in the pool when the body is given a small tilt angle?</p>
(A)	\overline{MG} is the metacentric height and G should lie below M
(B)	\overline{MG} is the metacentric height and B should lie above M
(C)	\overline{MB} is the metacentric height and B should lie below M
(D)	\overline{MB} is the metacentric height and G should lie above M

GATE 2025

IIT Roorkee

Q.34

Figure shows the steady and incompressible flow of a fluid in the direction of arrow from section A to section D. Three pipe connectors are to be placed between sections at A and D having Total Energy Line (TEL) and Hydraulic Grade Line (HGL) as depicted in the figure. Consider, g , P , Q , V , γ , and Z denote gravitational acceleration, pressure, volume flow rate, velocity, specific weight, and elevation of centerline of the pipe connectors from the datum, respectively.

Which one of the following options, in sequence, indicates the correct nature of connectors between sections A and B, B and C, and C and D in the direction of flow?

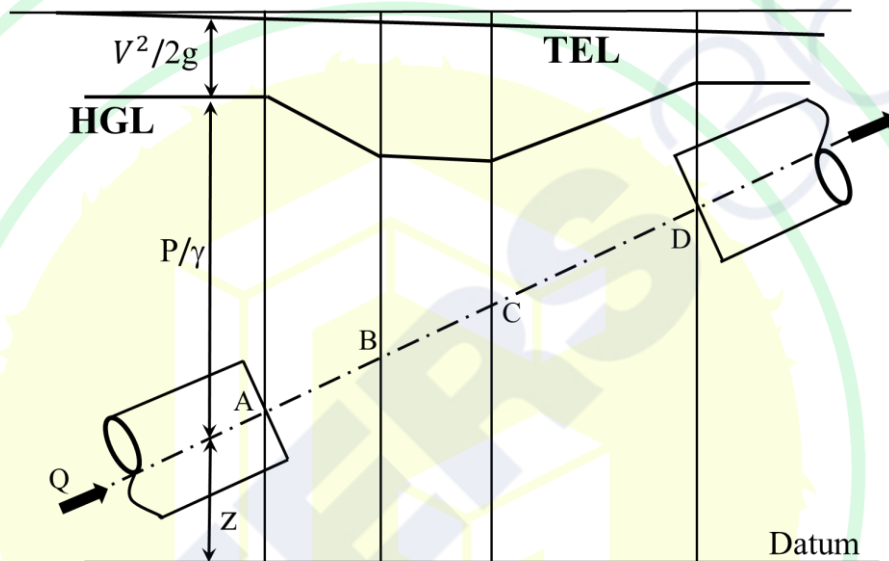

(A) Converging, Constant area, Diverging

(B) Diverging, Constant area, Converging

(C) Constant area, Constant area, Constant area

(D) Constant area, Converging, Diverging

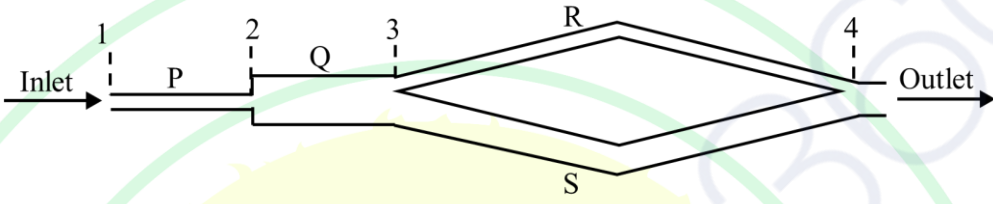
<p>Q.35</p>	<p>A liquid flows under steady and incompressible flow conditions from station 1 to station 4 through pipe sections P, Q, R, and S as shown in figure. Consider, d, V, and h represent the diameter, velocity, and head loss, respectively, in each pipe section with subscripts 'P', 'Q', 'R', and 'S'. Δh represents the head difference between the inlet (station 1) and outlet (station 4). All the pipe sections are placed on the same horizontal plane for which the figure shows the top view.</p> <p>Which one of the following options is correct for the given flow loop?</p>
	
(A)	$\Delta h = h_P + h_Q + h_R + h_S$ and $V_P d_P^2 = V_Q d_Q^2 = V_R d_R^2 = V_S d_S^2$
(B)	$\Delta h = h_P + h_Q + h_R$ and $V_P d_P^2 = V_Q d_Q^2 = V_R d_R^2 = V_S d_S^2$
(C)	$\Delta h = h_P + h_Q + h_R$ and $V_P d_P^2 = V_Q d_Q^2 = V_R d_R^2 + V_S d_S^2$
(D)	$\Delta h = h_P + h_Q + h_R + h_S$ and $V_P d_P^2 = V_Q d_Q^2 = V_R d_R^2 + V_S d_S^2$
<p>Q.36</p>	<p>Consider, i and j are unit vectors along x and y directions of a Cartesian (x, y) coordinate system, respectively and t is time. Temperature (T) and fluid velocity (\vec{V}) are given for a flow field as:</p> $T = x^2 + yt + 35$ $\vec{V} = (4xy)i + (xt - 2y^2)j$ <p>The total rate of change of temperature in the flow field (<i>in integer</i>) for time $t = 2$ at a point $(2, 3)$ is _____</p>

Q.37	Driven by a pressure gradient of 100 kPa/m, a fluid of dynamic viscosity 0.1 Pa.s flows between two fixed infinitely large parallel plates under steady, incompressible, and fully developed laminar conditions. The average velocity of the flow is 2 m/s. The gap between the parallel plates in mm (<i>rounded off to 2 decimal places</i>) is _____
Q.38	An incompressible fluid is flowing between two infinitely large parallel plates separated by 5 mm distance. The bottom plate is stationary and the top plate is moving at a constant velocity of 5 mm/s in the direction parallel to the bottom plate. The flow of the fluid between the plates is steady, two-dimensional, laminar, and the variation of fluid velocity is linear between the plates. A square fluid element of 1 mm side is considered at equal distance from both the plates in the flow field such that one of its sides is parallel to the plates. The magnitude of circulation in mm ² /s (<i>in integer</i>) along the edges of the square fluid element is _____
Q.39	Consider, a kite weighing 100 grams as essentially a rigid flat plate making an angle 8° with the horizontal and having a planform area of 0.045 m ² when exposed to horizontal parallel wind of 60 km/h. The thread string of the kite makes an angle 45° with the horizontal. A tension of 450 grams in the thread is necessary to float the kite steadily. Take air density as 1.2 kg/m ³ and gravitational acceleration as 9.81 m/s ² . The lift coefficient (C_L) associated with the air flow around steadily floating kite (<i>rounded off to 2 decimal places</i>) is _____

Q.40

A fixed control volume has four one-dimensional boundary sections (1, 2, 3, and 4). For a steady flow inside the control volume, the flow properties at each section are tabulated below:

Boundary Section	Type	Density (kg/m ³)	Surface Normal Velocity (m/s)	Cross-sectional Area (m ²)	Specific Energy (J/kg)
1	Inlet	1000	10	0.5	200
2	Inlet	1000	2	3.0	50
3	Outlet	1000	5	1.0	100
4	Outlet	1000	4	1.5	80

The rate of change of energy of the system which occupies the control volume at this instant is $E \times 10^6$ J/s. The value of E (rounded off to 2 decimal places) is _____

Q.41

A ship is to be operated in a fluid medium with kinematic viscosity 0.032×10^{-3} m²/s. A one-tenth scale model of the ship is built for testing. Consider, inertia, viscous and gravity forces are dominant for the ship and its model during the operation. The required kinematic viscosity of the liquid for testing the model is $P \times 10^{-6}$ m²/s. The value of P (rounded off to 2 decimal places) is _____

Q.42

Water flows through a pipe of diameter 20 cm at a flow rate of 0.025 m³/s. A pitot-static tube is placed at the centre of the pipe and indicates the pressure difference of 5 cm of water column. Theoretical velocity measured through pitot-static tube when multiplied with velocity coefficient C_V gives the actual velocity of the flow. If the mean velocity in the pipe is 90% of the actual velocity at the centre of the pipe and the gravitational acceleration is 10 m/s², the value of C_V (rounded off to 2 decimal places) is _____



Q.43	An oil of density 870 kg/m^3 and viscosity $0.036 \text{ Pa}\cdot\text{s}$ flows through a straight pipe of 10 cm diameter and 1.5 km length at the flow rate of 250 liters per minute under the steady and incompressible flow conditions. To control the flow rate of oil, a valve is fixed at the middle of the pipe causing no change in the total length of the pipe. The total head loss measured across the two ends of the pipe is 11.60 m. Using gravitational acceleration as 10 m/s^2 , the minor head loss contributed by the presence of the valve in m (<i>rounded off to 2 decimal places</i>) is _____



Materials Science (XE-C)

Q.44 – Q.52 Carry ONE mark Each

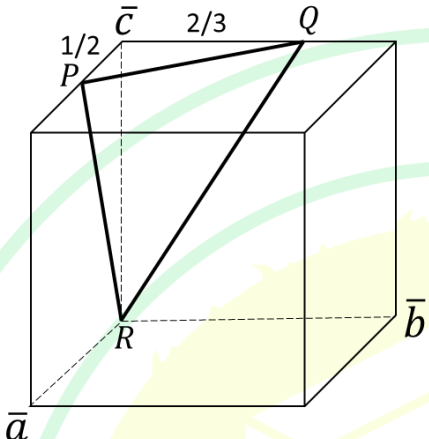
Q.44	The figure below shows a plane PQR in a unit cell. The Miller indices of the plane PQR is
	 <p>The diagram shows a 3D unit cell with axes \bar{a}, \bar{b}, and \bar{c}. A plane PQR is drawn. Point P is on the \bar{c} axis at $1/2$. Point Q is on the \bar{c} axis at $2/3$. Point R is on the \bar{a} axis at 1. The Miller indices of the plane PQR are to be determined.</p>
(A)	(432)
(B)	$(4\bar{3}2)$
(C)	$(2\bar{3}\bar{4})$
(D)	$(\bar{2}\bar{3}\bar{4})$

Q.45	The unit of measurement for magnetic dipole moment of a body is
(A)	$A\ m^2$
(B)	$A\ m^{-1}$
(C)	$Wb\ m^{-2}$
(D)	$Wb\ m^2$
Q.46	B is the magnetic flux density and T_c is the critical temperature. The Meissner effect is represented by
(A)	$B = 0$ at $T \leq T_c$
(B)	$B = 0$ at $T > T_c$
(C)	$B \neq 0$ at $T \leq T_c$
(D)	$\nabla B = 0$ at $T = T_c$

Q.47	For Al – 4.5 wt% Cu alloy, the correct sequence of precipitation during age hardening at room temperature is
(A)	GP zone $\rightarrow \theta'' \rightarrow \theta' \rightarrow \theta$
(B)	GP zone $\rightarrow \theta' \rightarrow \theta'' \rightarrow \theta$
(C)	GP zone $\rightarrow \theta'' \rightarrow \theta \rightarrow \theta'$
(D)	GP zone $\rightarrow \theta \rightarrow \theta' \rightarrow \theta''$
Q.48	There is NO base-centered cubic lattice among the list of 14 Bravais lattices because of one or more of the following reasons
(A)	It does NOT have translational symmetry
(B)	It is only compatible with the symmetry of orthorhombic crystal system
(C)	It is only compatible with the symmetry of tetragonal crystal system
(D)	It does NOT have 3-fold rotation axes along the body diagonals

Q.49	For a conventional optical microscope, which of the following options regarding the resolution limit and the depth of field is/are correct?
(A)	Resolution limit decreases with decreasing wavelength of light
(B)	Resolution limit decreases with decreasing refractive index of the medium
(C)	Depth of field decreases with increasing value of numerical aperture of the objective lens
(D)	Resolution limit decreases with increasing value of numerical aperture of the objective lens
Q.50	Which of the following phenomenon/phenomena contribute to intensity loss of electromagnetic radiation during transmission through a medium?
(A)	Electronic absorption
(B)	Rayleigh scattering
(C)	Photon – phonon interaction
(D)	Stimulated emission



Q.51	If solid tin is in equilibrium with its vapor, the degree of freedom is (answer in integer) _____
Q.52	A GaP–GaAs semiconductor LED display has a band gap of 1.9 eV. The wavelength of emitted light in μm is (rounded off to two decimal places) _____ Given: Planck’s constant = $6.63 \times 10^{-34} \text{ J s}$ Velocity of light = $3 \times 10^8 \text{ m s}^{-1}$ 1 eV = $1.6 \times 10^{-19} \text{ J}$

GATE 2025

IIT Roorkee

Q.53 – Q.65 Carry TWO marks Each

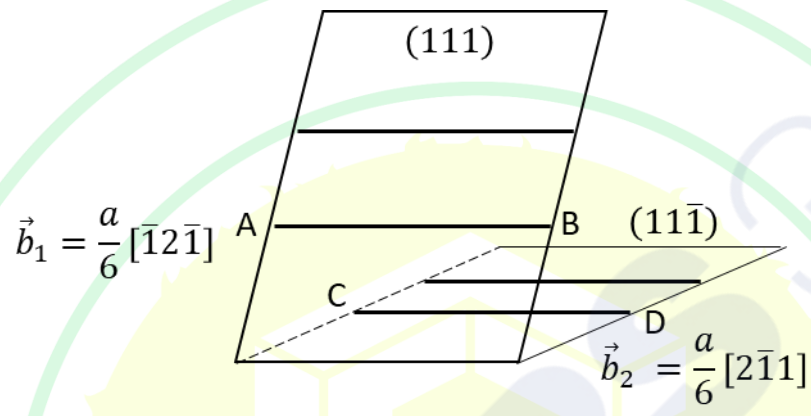
<p>Q.53</p>	<p>In an FCC crystal with lattice parameter a, consider the reaction of two leading partial dislocations, AB and CD, at the line of intersection of their slip planes (111) and $(11\bar{1})$, respectively, as shown in the figure below. Dislocations, AB and CD, have Burgers vectors \vec{b}_1 and \vec{b}_2, respectively, as given in the figure. Which one of the following options for the slip plane and the Burgers vector of the resulting dislocation is correct?</p>
	 <p>The diagram shows two intersecting slip planes, (111) and $(11\bar{1})$. Dislocation AB is on the (111) plane with Burgers vector $\vec{b}_1 = \frac{a}{6} [\bar{1}2\bar{1}]$. Dislocation CD is on the $(11\bar{1})$ plane with Burgers vector $\vec{b}_2 = \frac{a}{6} [2\bar{1}1]$. The intersection line is shown as a dashed line.</p>
<p>(A)</p>	<p>Slip plane is (001) and Burgers vector is $\frac{a}{6} [110]$</p>
<p>(B)</p>	<p>Slip plane is $(1\bar{1}1)$ and Burgers vector is $\frac{a}{6} [110]$</p>
<p>(C)</p>	<p>Slip plane is (001) and Burgers vector is $\frac{a}{2} [110]$</p>
<p>(D)</p>	<p>Slip plane is $(\bar{1}11)$ and Burgers vector is $\frac{a}{2} [110]$</p>

Q.54	<p>Match the detector for a scanning electron microscope (SEM) in Column I with the resulting output in Column II.</p> <p>SE: Secondary electrons; BSE: Backscattered electrons;</p> <p>EDS: Energy Dispersive Spectroscopy; EBSD: Electron Backscatter Diffraction</p>		
	<table border="0" style="width: 100%;"> <tr> <td style="width: 50%; vertical-align: top;"> <p>Column I</p> <p>(P) SE Detector</p> <p>(Q) BSE Detector</p> <p>(R) EDS Detector</p> <p>(S) EBSD Detector</p> </td> <td style="width: 50%; vertical-align: top;"> <p>Column II</p> <p>(1) Elemental composition analysis</p> <p>(2) Kikuchi lines</p> <p>(3) Topographic image</p> <p>(4) Compositional contrast image</p> </td> </tr> </table>	<p>Column I</p> <p>(P) SE Detector</p> <p>(Q) BSE Detector</p> <p>(R) EDS Detector</p> <p>(S) EBSD Detector</p>	<p>Column II</p> <p>(1) Elemental composition analysis</p> <p>(2) Kikuchi lines</p> <p>(3) Topographic image</p> <p>(4) Compositional contrast image</p>
<p>Column I</p> <p>(P) SE Detector</p> <p>(Q) BSE Detector</p> <p>(R) EDS Detector</p> <p>(S) EBSD Detector</p>	<p>Column II</p> <p>(1) Elemental composition analysis</p> <p>(2) Kikuchi lines</p> <p>(3) Topographic image</p> <p>(4) Compositional contrast image</p>		
(A)	P-4; Q-3; R-1; S-2		
(B)	P-2; Q-4; R-1; S-3		
(C)	P-3; Q-4; R-2; S-1		
(D)	P-3; Q-4; R-1; S-2		

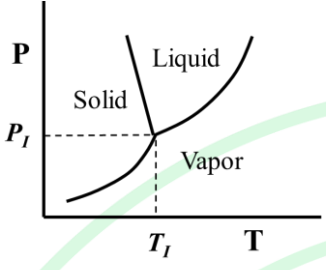
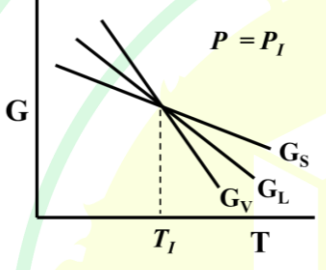
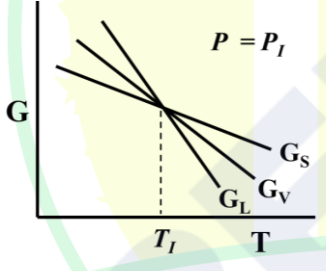
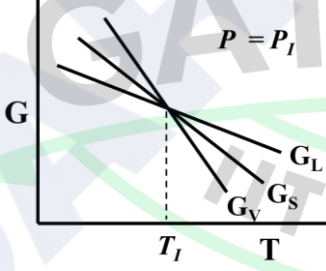
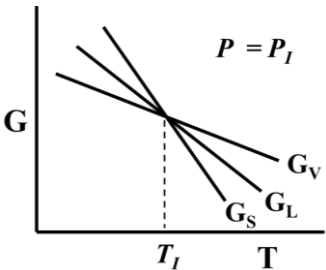
<p>Q.55</p>	<p>The triple point (T_I, P_I) is shown in a schematic phase diagram (pressure (P) – temperature (T) plot) for one component system. G_S, G_L and G_V are the free energies of solid, liquid and vapor, respectively. At a constant pressure, P_I, the correct free energy (G) versus temperature (T) plot is</p>
	
<p>(A)</p>	
<p>(B)</p>	
<p>(C)</p>	
<p>(D)</p>	

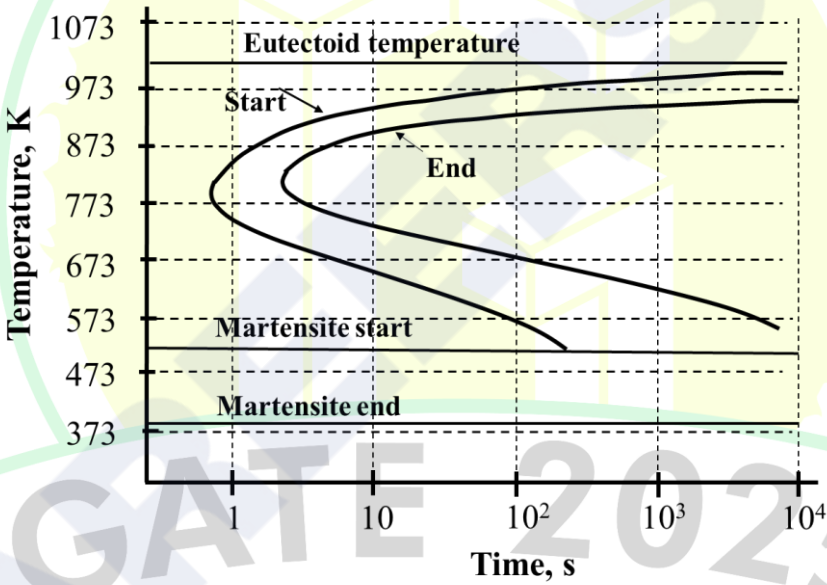
<p>Q.56</p>	<p>The TTT diagram for eutectoid steel is shown below. The steel after complete austenitization at 1073 K is rapidly cooled to different temperatures and held for varying times (as indicated in Column I) followed by quenching to 300 K. Assuming isothermal transformation, match the heat treatment conditions in Column I with the corresponding microstructure in Column II.</p> <table border="0" style="width: 100%;"> <tr> <td style="width: 50%;">Column I</td> <td style="width: 50%;">Column II</td> </tr> <tr> <td>(P) Held at 300 K indefinitely</td> <td>(1) Bainite</td> </tr> <tr> <td>(Q) Held at 873 K for 4 minutes</td> <td>(2) Martensite</td> </tr> <tr> <td>(R) Held at 673 K for 20 minutes</td> <td>(3) Pearlite</td> </tr> <tr> <td>(S) Held at 623 K for 2 minutes</td> <td>(4) Bainite + Martensite</td> </tr> </table>	Column I	Column II	(P) Held at 300 K indefinitely	(1) Bainite	(Q) Held at 873 K for 4 minutes	(2) Martensite	(R) Held at 673 K for 20 minutes	(3) Pearlite	(S) Held at 623 K for 2 minutes	(4) Bainite + Martensite
Column I	Column II										
(P) Held at 300 K indefinitely	(1) Bainite										
(Q) Held at 873 K for 4 minutes	(2) Martensite										
(R) Held at 673 K for 20 minutes	(3) Pearlite										
(S) Held at 623 K for 2 minutes	(4) Bainite + Martensite										
											
(A)	P – 3; Q – 2; R – 1; S – 4										
(B)	P – 2; Q – 3; R – 1; S – 4										
(C)	P – 2; Q – 1; R – 3; S – 4										
(D)	P – 4; Q – 3; R – 1; S – 2										

Q.57	<p>A diffraction pattern is obtained from a powdered sample of a pure element, which has FCC crystal structure. If x and y are the Bragg angles of the first and the third peaks, respectively, then the ratio, $\frac{\sin y}{\sin x}$, is (rounded off to one decimal place) _____</p>
Q.58	<p>For a pure element with a BCC crystal structure, the surface energies per unit area of $\{100\}$ and $\{110\}$ free surfaces are S_{100} and S_{110}, respectively. The ratio, $\frac{S_{100}}{S_{110}}$, is (rounded off to one decimal place) _____</p>
Q.59	<p>On applying 10 V across the two ends of a 100 cm long copper wire, the average drift velocity (in cm s^{-1}) in the wire is (rounded off to two decimal places) _____</p> <p>Given: Electron density of copper = $8.43 \times 10^{22} \text{ cm}^{-3}$ Copper resistivity = $1.67 \times 10^{-6} \Omega \text{ cm}$ Electron charge = $1.6 \times 10^{-19} \text{ C}$</p>
Q.60	<p>An aluminum transmission line of 7 km length is designed to carry 100 A current with no more than 2 MW power loss. The required minimum diameter (in mm) of the transmission line is (rounded to the two decimal places) _____</p> <p>Given: Aluminum conductivity = $3.77 \times 10^5 \Omega^{-1} \text{ cm}^{-1}$</p>

<p>Q.61</p>	<p>An electric field is applied on a copper plate such that the electrons are displaced by 1.1×10^{-18} m relative to the nucleus. The electronic polarization (in $\mu\text{C m}^{-2}$) is (rounded off to two decimal places)_____</p> <p>Given: Atomic number of copper = 29 Copper has FCC crystal structure with lattice parameter = 0.362 nm Electron charge = 1.6×10^{-19} C</p>
<p>Q.62</p>	<p>The standard free energy change for the reaction, $\text{SO}_2 + \frac{1}{2}\text{O}_2 \rightleftharpoons \text{SO}_3$ at equilibrium is given by $\Delta G^\circ = -94600 + 89.37T$, where T is in Kelvin and ΔG° is in Joule. The equilibrium constant (K_P) at 1050 K is (rounded off to two decimal places) _____</p> <p>Given: Universal gas constant (R) = $8.314 \text{ J K}^{-1} \text{ mol}^{-1}$</p>
<p>Q.63</p>	<p>The slopes of reduction potential versus pH plots for the two reactions, $\text{NiO} + 2\text{H}^+ + 2\text{e}^- \rightleftharpoons \text{Ni} + \text{H}_2\text{O}$ and $2\text{H}^+ + 2\text{e}^- \rightleftharpoons \text{H}_2$, at 298 K and one atmospheric pressure are S_1 and S_2, respectively. The ratio $\frac{S_1}{S_2}$ is (rounded off to one decimal place) _____</p>
<p>Q.64</p>	<p>At 873 K, hydrogen diffuses under steady state condition through a 5 mm thick palladium sheet with a cross-sectional area of 0.3 m^2. The concentrations of hydrogen at high and low pressure ends of the sheet are 3 kg m^{-3} and 0.5 kg m^{-3}, respectively. The amount of hydrogen (in kg per day) passing through the sheet is (rounded off to two decimal places) _____</p> <p>Given: At 873 K, diffusivity of hydrogen = $1.8 \times 10^{-8} \text{ m}^2 \text{ s}^{-1}$</p>



Q.65

Corrosion of pure iron takes place in an acidic electrolyte by forming Fe^{2+} ions at ambient condition. The corrosion current density is measured to be $2 \times 10^{-4} \text{ A cm}^{-2}$. The corrosion rate (in mm per year) of iron is (rounded off to one decimal place)

Given: Atomic weight of iron = 55.85

Density of iron = 7.86 g cm^{-3}

Consider 365 days in a year

1 Faraday = 96500 Coulomb mol^{-1}

GATE 2025

IIT Roorkee

Solid Mechanics (XE-D)

Q.66 – Q.74 Carry ONE mark Each

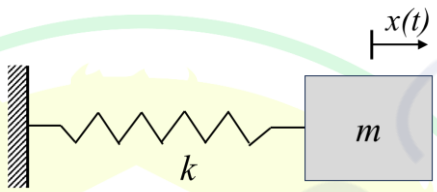
<p>Q.66</p>	<p>Consider a spring-mass system with mass m and spring stiffness k as shown in the illustration. At time $t=0$, the mass is displaced by P units and the velocity of the mass is zero. The displacement of the mass, $x(t)$, is measured from the equilibrium position.</p> <p>Which one of the following functions represent $x(t)$?</p>
	
<p>(A)</p>	$P \cos\left(\sqrt{\frac{k}{m}}t\right) + P \sin\left(\sqrt{\frac{k}{m}}t\right)$
<p>(B)</p>	$P \sin\left(\sqrt{\frac{k}{m}}t\right)$
<p>(C)</p>	$\frac{P}{2} \cos\left(\sqrt{\frac{k}{m}}t\right) + \frac{P}{2} \sin\left(\sqrt{\frac{k}{m}}t\right)$
<p>(D)</p>	$P \cos\left(\sqrt{\frac{k}{m}}t\right)$



Q.67	<p>A ball of mass $5m$ approaches a stationary ball of mass m with a horizontal velocity of 2 m/s from left to right. After a perfectly elastic central collision, the horizontal velocity of the heavier ball is 1 m/s from left to right.</p> <p>Which one of the following statements, regarding the velocity (in m/s) of the lighter ball after impact, is TRUE?</p>
(A)	Comes to rest
(B)	Moves from left to right at 5 m/s
(C)	Moves from right to left at 5 m/s
(D)	Moves from left to right at 1 m/s

GATE 2025
IIT Roorkee

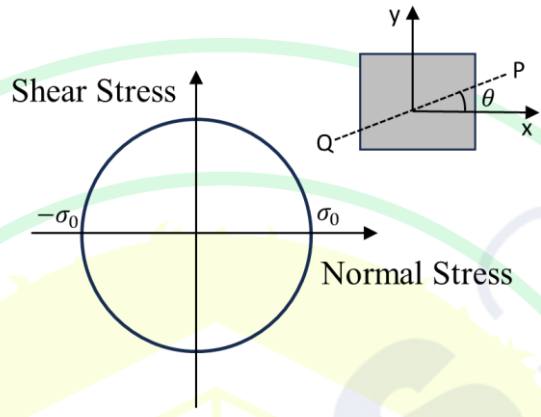
<p>Q.68</p>	<p>The Mohr's circle corresponding to an infinitesimal element is shown in the figure. The plane PQ in the infinitesimal element, at an angle of θ from the x-axis, is in a state of pure shear.</p> <p>Which one of the following values of θ (in degrees) is CORRECT?</p>
	 <p>The figure shows a Mohr's circle on a coordinate system where the horizontal axis is Normal Stress and the vertical axis is Shear Stress. The circle is centered on the horizontal axis at the origin, with its leftmost point at $-\sigma_0$ and its rightmost point at σ_0. To the right of the circle, a square element is shown with a coordinate system (x, y). A dashed line representing a plane PQ is drawn at an angle θ from the x-axis. The element is in a state of pure shear on this plane.</p>
(A)	90
(B)	60
(C)	45
(D)	120



Q.69	<p>The two-dimensional state of stress, in an infinitesimal element, is given by</p> $\sigma_{xx} = 800 \text{ MPa}, \sigma_{xy} = 300 \text{ MPa} \text{ and } \sigma_{yy} = 0 \text{ MPa.}$ <p>Which one of the following options is the maximum shear stress (in MPa) in the element?</p>
(A)	500
(B)	400
(C)	800
(D)	300

GATE 2025

IIT Roorkee

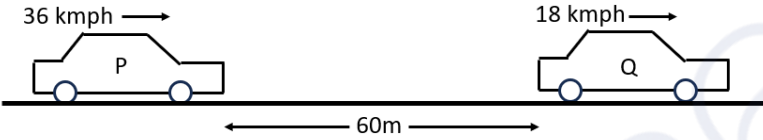
<p>Q.70</p>	<p>Two cars P and Q are travelling on a straight path and are 60 m apart as shown in the figure; Car P is moving with a constant velocity of 36 kmph, while car Q is moving at a constant velocity of 18 kmph. At this instant, the driver in car P applies the brake and collision occurs with car Q after 30 seconds.</p> <p>Assuming uniform deceleration due to braking, which one of the following is the CORRECT velocity (in m/s) of the car P just before the collision?</p>
	
(A)	1
(B)	16
(C)	5
(D)	4
<p>Q.71</p>	<p>The natural frequency of a spring-mass system is 10 rad/s. Which of the following statements is/are CORRECT?</p>
(A)	The mass is 100 kg and the stiffness is 1 N/m.
(B)	The mass is 1.25 kg and the stiffness is 125 N/m.
(C)	The stiffness is 620 N/m and the mass is 6.2 kg.
(D)	The stiffness is 62 N/m and the mass is 620 kg.

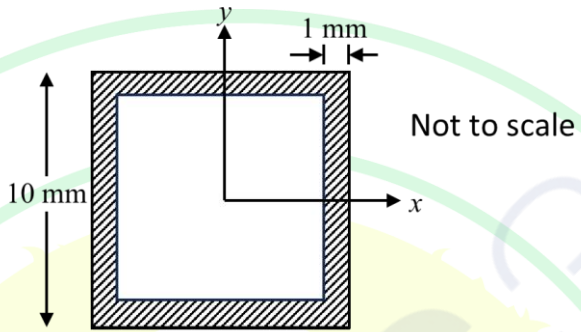
<p>Q.72</p>	<p>Consider a beam with a square box cross-section as shown in the figure. The outer square has a length of 10 mm. The thickness of the section is 1 mm.</p> <p>The area moment of inertia about the x-axis is _____ mm^4 (<i>in integer</i>).</p>
	
<p>Q.73</p>	<p>For a certain linear elastic isotropic material, the Young's modulus is 140 GPa and the shear modulus is 50 GPa.</p> <p>The Poisson's ratio for the material is _____ (<i>rounded off up to two decimal places</i>).</p>

Q.74

A force of $P = 100\text{ N}$ is applied at the ends of the pliers as shown in the figure. Neglecting friction, the force exerted by the upper jaw on the workpiece is _____ N (*in integer*).

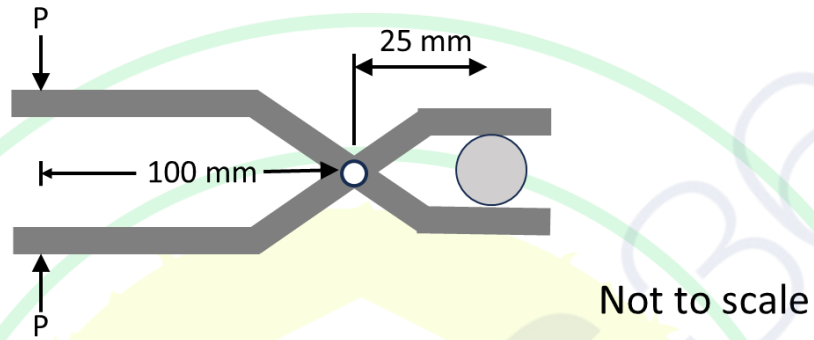

GATE 2025
IIT Roorkee

Q.75 – Q.87 Carry TWO marks Each

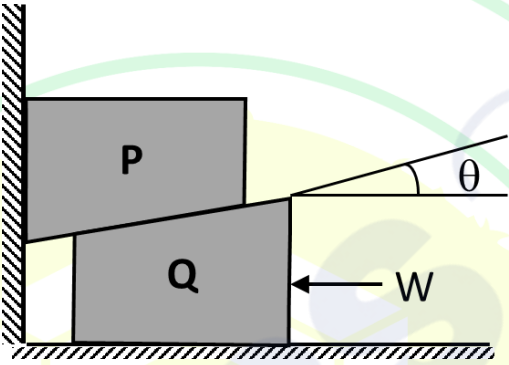
<p>Q.75</p>	<p>Consider two blocks, P of mass 100 kg and Q of mass 150 kg, resting as shown in the figure. The angle $\theta = 30^\circ$. The coefficient of friction between the two blocks is 0.2. Assume no friction exists at all other interfaces. The minimum force required to move the block P upward is W.</p> <p>Which one of the following options is closest to the CORRECT magnitude of W (in N)?</p>
	
<p>(A)</p>	<p>862.2</p>
<p>(B)</p>	<p>1116.6</p>
<p>(C)</p>	<p>2900.0</p>
<p>(D)</p>	<p>406.2</p>
	<p style="text-align: center; font-size: 2em; opacity: 0.5;">GATE 2025</p>
	<p style="text-align: center; font-size: 1.5em; opacity: 0.5;">IIT Roorkee</p>



Q.76	Which one of the following vertical columns, of circular cross-section, sustains the highest load without buckling?
(A)	Cantilever column with a length L and cross-section diameter d
(B)	Column with hinge at one end and roller at the other end with a length $2L$ and cross-section diameter d
(C)	Cantilever column with a length L and cross-section diameter $2d$
(D)	Column with hinge at one end and roller at the other end with a length L and cross-section diameter d

GATE 2025

IIT Roorkee

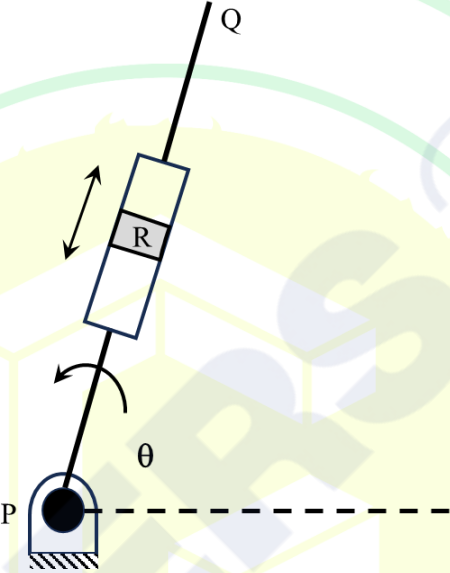
<p>Q.77</p>	<p>The figure shows a rod PQ, hinged at P, rotating counter-clockwise with a uniform angular speed of 15 rad/s. A block R translates along a slot cut out in rod PQ. At the instant shown the distance PR = 0.5 m and $\theta = 60^\circ$. The relative velocity of R with respect to the rod PQ is 5 m/s at the instant shown. The relative acceleration of R with respect to the rod PQ is zero at the instant shown.</p> <p>Which one of the following is the CORRECT magnitude of the absolute acceleration (in m/s^2) of block R?</p>
	
(A)	135.2
(B)	187.5
(C)	112.5
(D)	150.0

Q.78

The frame shown in the figure is loaded at S with a force of 2000 N. The reactions at T are denoted by T_x and T_y , while the reaction at W is W_y . Neglect the weight of the members.

Which one of the following options for the magnitudes of the forces (in N), T_x , T_y and W_y , is CORRECT?

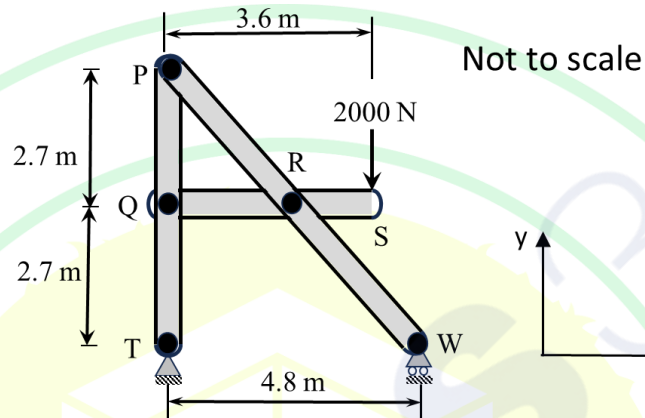

(A) $T_x = 0$, $T_y = 1000$ and $W_y = 1000$

(B) $T_x = 0$, $T_y = 1500$ and $W_y = 500$

(C) $T_x = 0$, $T_y = 800$ and $W_y = 1200$

(D) $T_x = 0$, $T_y = 500$ and $W_y = 1500$

GATE 2025

IIT Roorkee



Q.79	<p>A closed thin cylindrical tank with a mean diameter $d = 300$ mm and thickness $t = 2$ mm, is subjected to a uniform internal gas pressure p. The allowable shear stress on the curved wall of the tank is 70 MPa.</p> <p>Based on the Tresca criteria, which one of the following options for the maximum safe value of p (in MPa) is CORRECT?</p>
(A)	3.73
(B)	7.46
(C)	1.87
(D)	5.60

GATE 2025

IIT Roorkee

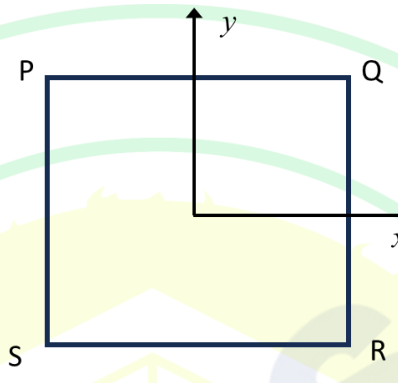
<p>Q.80</p>	<p>An infinitesimal square element PQRS is shown in the figure. The x and y axes are also marked in the figure. The strains on the element are given by</p> $\epsilon_{xx} = 500 \times 10^{-6}, \epsilon_{yy} = 100 \times 10^{-6} \text{ and } \epsilon_{xy} = 0.$ <p>Which of the following statements is/are CORRECT?</p>
	
(A)	<p>Percentage change in length of the diagonal PR is 0.03.</p>
(B)	<p>Change in angle between PR and QS is 4×10^{-4} rad.</p>
(C)	<p>Change in angle between PR and QS is 2×10^{-4} rad.</p>
(D)	<p>Percentage change in length of the diagonal QS is 0.03.</p>

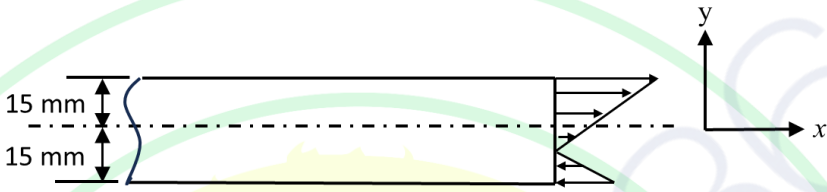
<p>Q.81</p>	<p>The figure shows the stress distribution across an internal surface of a rectangular beam of height 30 mm and depth 10 mm. The normal stress distribution is given by the expression $\sigma_{xx} = 200y + 500$ N/mm²; y is the distance in mm from the centroidal axis of the beam. Assume that there is no variation in the stress distribution along the z-direction.</p> <p>Which of the following statements is/are CORRECT?</p>
	
<p>(A)</p>	<p>The net force in the x direction is 150 kN.</p>
<p>(B)</p>	<p>The net force in the x direction is 75 kN.</p>
<p>(C)</p>	<p>The net moment about the z axis is 4500 Nm.</p>
<p>(D)</p>	<p>The net moment about the z axis is 2250 Nm.</p>
<p>Q.82</p>	<p>A vertical column fixed at one end is subjected to a compressive axial load at the free end. The column's section modulus, EI, is 9.82×10^5 Nm² and the cross-section area is 7.85×10^{-3} m². The length of the column is 2 m. The yield stress of the material is 145 MPa.</p> <p>If the column can fail either in buckling or by Tresca's criterion, the maximum load that the structure can safely sustain is _____ kN (<i>rounded off to one decimal place</i>).</p>

Q.83

A simply-supported beam, with a point load $P = 150 \text{ kN}$ at a distance of $L/3$ from the left end, is shown in the figure. The elastic-strain energy (U) of the beam is given by the following expression:

$$U = \frac{2}{243} \frac{P^2 L^3}{EI}$$

where the section modulus, EI , is $16.66 \times 10^5 \text{ Nm}^2$ and the length of the beam L is 1 m.

The deflection at the loading point is ____ mm (rounded off to two decimal places).

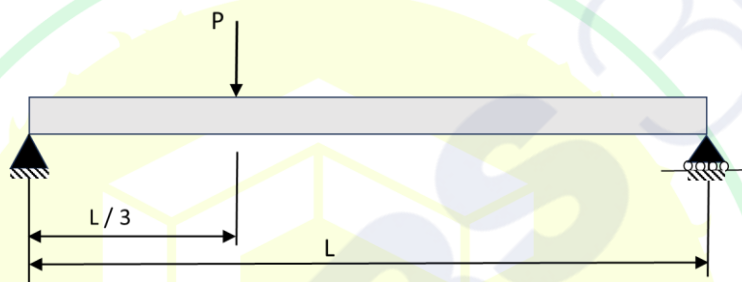

Q.84

A simply-supported beam has a circular cross-section with a diameter of 20 mm, area of 314.2 mm^2 , area moment of inertia of 7854 mm^4 and a length L of 4 m. A point load $P = 100 \text{ N}$ acts at the center and an axial load $Q = 20 \text{ kN}$ acts through the centroidal axis as shown in the figure.

The magnitude of the offset between the neutral axis and the centroidal axis, at $L/2$ from the left, is _____ mm (rounded off to one decimal place).

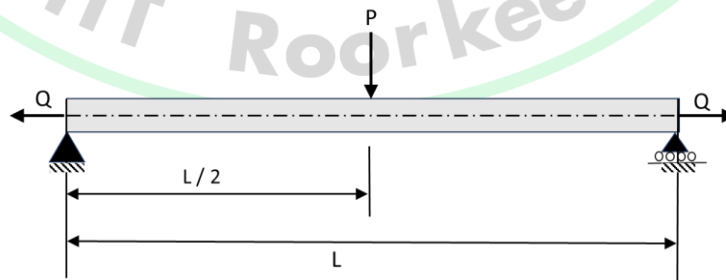

<p>Q.85</p>	<p>A massless cantilever beam, with a tip mass m of 10 kg, is modeled as an equivalent spring-mass system as shown in the figure. The beam is of length $L = 1$ m, with a circular cross-section of diameter $d = 20$ mm. The Young's modulus of the beam material is 200 GPa.</p> <p>The natural frequency of the spring-mass system is _____ Hz (<i>rounded off to two decimal places</i>).</p>
	
<p>Q.86</p>	<p>An electric motor's rotor is spinning at 1500 rpm when its load and power are cut-off. The rotor which has a mass of 50 kg and a radius of gyration of 200 mm, then coasts down to rest. Due to kinetic friction, a constant torque of 10 Nm acts on the rotor as it coasts down.</p> <p>The number of revolutions executed by the rotor before it comes to rest is _____ (<i>in integer</i>).</p>

Q.87

A bar of length $L = 1$ m is fixed at one end. Before heating its free end has a gap of $\delta = 0.1$ mm from a rigid wall as shown in the figure. Now the bar is heated resulting in a uniform temperature rise of 10 °C. The coefficient of linear thermal expansion of the material is $20 \times 10^{-6} / ^\circ\text{C}$ and the Young's modulus of elasticity is 100 GPa. Assume that the material properties do not change with temperature.

The magnitude of the resulting axial stress on the bar is _____ MPa (*in integer*).

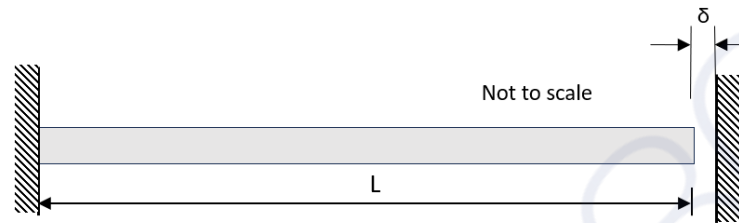

GATE 2025

IIT Roorkee

Thermodynamics (XE-E)

Q.88 – Q.96 Carry ONE mark Each

Q.88	A tank is divided into two compartments with one compartment containing a gas at a given pressure, while the second is completely evacuated. If the partition is removed, the gas occupies the entire compartment. Which one of the following statements is CORRECT?
(A)	Work done is equal to the area under the curve of a $p-V$ diagram
(B)	Expansion of gas is not restrained by external force
(C)	The entire process is reversible
(D)	The overall change in volume is zero for the entire system
Q.89	A cylinder of volume 0.1 m^3 is filled with nitrogen at 10 MPa and 300 K. Consider nitrogen to be an ideal gas. The cylinder develops a leak and nitrogen escapes to atmosphere which is at 0.1 MPa. After sometime, the pressure in the cylinder reduces to 5 MPa. Assuming the cylinder and the leaked gas temperature remains constant at 300 K, the work done (in MJ) by nitrogen gas is
(A)	0.1
(B)	1
(C)	0.5
(D)	10

Q.90	A closed system undergoes a process 1–2 in which it absorbs 150 kJ of energy as heat and does 90 kJ of work. Then it follows another process 2–3 in which 80 kJ of work is done on it while it rejects 60 kJ as heat. If it is desired to restore the system to the initial state (state 1) by an adiabatic path, the work interaction (in kJ) in this process will be
(A)	80
(B)	100
(C)	50
(D)	70
Q.91	The inlet and outlet temperatures of the flowing fluid during a steady state flow process are the same as that of the surroundings. If the changes in kinetic and potential energies are neglected, the maximum power that can be obtained is equal to
(A)	the rate of increase in enthalpy of the flowing fluid
(B)	the rate of decrease in Helmholtz energy of the flowing fluid
(C)	the rate of decrease in Gibbs free energy of the flowing fluid
(D)	the rate of decrease in internal energy of the flowing fluid

Q.92	If γ refers to the ratio of specific heats, the air-standard efficiency of an Otto cycle is
(A)	$1 - \frac{1}{(\text{Compression ratio})^\gamma}$
(B)	$1 - \frac{1}{(\text{Pressure ratio})^{\frac{\gamma-1}{\gamma}}}$
(C)	$1 - \frac{1}{(\text{Compression ratio})^{(\gamma-1)}}$
(D)	$1 - \frac{1}{(\text{Pressure ratio})^{(\gamma-1)}}$
Q.93	Let T_H and T_L denote the absolute temperatures of high and low temperature reservoirs, respectively. The coefficient of performance of a reversible refrigerator operating between these two reservoirs is
(A)	$\frac{1}{\frac{T_H}{T_L} - 1}$
(B)	$\frac{1}{1 - \frac{T_H}{T_L}}$
(C)	$\frac{1}{\frac{T_L}{T_H} - 1}$
(D)	$\frac{1}{\frac{T_L}{T_H} + 1}$

Q.94	<p>A tank of 4 m³ contains an ideal gas mixture of 60% hydrogen and 40% nitrogen by volume at 100 kPa and 300 K. Nitrogen is added to the tank such that the composition changes to 50% nitrogen by volume, with a final temperature of 300 K. The amount of nitrogen (in kmol) to be added is _____ (<i>rounded off to three decimal places</i>).</p> <p>Use: Universal gas constant (R_u) = 8.314 kJ/kmol-K</p>
Q.95	<p>A heat engine having thermal efficiency of 40% receives heat from a source at 600 K and rejects heat to a sink at 300 K. The second-law efficiency (in %) of this engine is _____ (<i>answer in integer</i>).</p>
Q.96	<p>A rigid tank of 300 litre capacity contains 3 kg of oxygen (molar mass = 32 kg/kmol) at 25 °C. If oxygen behaves as an ideal gas, the pressure (in kPa) inside the tank is _____ (<i>rounded off to two decimal places</i>).</p> <p>Use: Universal gas constant (R_u) = 8.314 kJ/kmol-K</p>

Q.97 – Q.109 Carry TWO marks Each

Q.97	For an ideal gas turbine cycle, T_1 and T_3 are the compressor inlet temperature and turbine inlet temperature respectively. The ratio $\frac{T_3}{T_1}$ is denoted by t and the ratio of specific heats is denoted by γ . For any given t , the optimum pressure ratio for the maximum specific work output is
(A)	$t^{\frac{2}{\gamma-1}}$
(B)	$t^{\frac{\gamma}{2(\gamma-1)}}$
(C)	$t^{\frac{\gamma}{\gamma-1}}$
(D)	$t^{\frac{\gamma-1}{\gamma}}$
Q.98	For a pure substance that expands on freezing, which of the following statement(s) is/are CORRECT?
(A)	Temperature of the liquid phase can be lower than the temperature at the triple point
(B)	Critical pressure is equal to the pressure at the triple point
(C)	Highest pressure at which the vapour phase can exist is the pressure at the triple point
(D)	Highest temperature at which solid-liquid phase change can happen is the temperature at the triple point

Q.99	Consider a gas obeying the relation $P(v-b) = RT$, where b and R are constants. Which of the following statement(s) is/are CORRECT about the specific heat capacity at constant pressure?
(A)	It is independent of temperature
(B)	It is a function of pressure
(C)	It is a function of temperature
(D)	It is independent of both specific volume and pressure
Q.100	A piston-cylinder arrangement contains an ideal gas mixture of 4 kg of hydrogen and 13 kg of nitrogen at 250 K and atmospheric pressure. On heat addition, the mixture expands at constant pressure until the temperature rises to 350 K. The average isobaric specific heats (c_p) for hydrogen and nitrogen are 14.239 kJ/kg-K and 1.040 kJ/kg-K, respectively. The amount of heat (in MJ) added to the cylinder is _____ (rounded off to three decimal places).
Q.101	Air in an ideal Diesel cycle is compressed from 3 litre to 0.15 litre. It then expands during a constant pressure heat addition process to 0.3 litre. If the ratio of specific heats, $\gamma = 1.4$, the thermal efficiency (in %) of the cycle is _____ (rounded to one decimal place).

<p>Q.102</p>	<p>Air at 101 kPa, 15 °C and 50% relative humidity is first heated to 20 °C in a heating coil, and then humidified by spraying water on it. In the final state, the air has temperature of 25 °C and relative humidity of 85%. The amount of water sprayed (in gm per kg of dry air) is _____ (rounded off to two decimal places).</p> <p>Use the following data:</p> <p>The saturation pressure of water at 15 °C = 1.7057 kPa</p> <p>The saturation pressure of water at 25 °C = 3.1698 kPa</p>
<p>Q.103</p>	<p>A stream of superheated steam (2 MPa, 300 °C) mixes with another stream of superheated steam (2 MPa, 400 °C) through a steady-state adiabatic process. The flow rates of the streams are 3 kg/min and 2 kg/min, respectively. This mixture then expands in an adiabatic nozzle to a saturated mixture with quality of 0.77 and 1 kPa. Neglect the velocity at the nozzle entrance and the change in potential energies. The velocity at the nozzle exit (in m/s) is _____ (rounded off to two decimal places).</p> <p>Use the following data:</p> <p>At 2 MPa, 300 °C: Specific enthalpy of superheated steam = 3024.2 kJ/kg</p> <p>At 2 MPa, 400 °C: Specific enthalpy of superheated steam = 3248.4 kJ/kg</p> <p>At 1 kPa: Specific enthalpy of saturated water = 29.3 kJ/kg</p> <p>At 1 kPa: Specific enthalpy of saturated vapour = 2513.7 kJ/kg</p>
<p>Q.104</p>	<p>A piston-cylinder assembly having 250 mm diameter contains 0.01 kg of water vapor at 1 MPa and 200 °C. The specific volume of the vapor is 0.20602 m³/kg. The system expands as per the relation $pV^n = \text{constant}$, where p is pressure and V is volume. The expansion of water vapour displaces the piston by 50 mm. If the final pressure is 0.35 MPa, the value of the exponent (n) is _____ (rounded off to two decimal places).</p>

Q.105	Air enters a hair dryer at 22 °C and 100 kPa with a velocity of 3.7 m/s, and leaves the dryer at 83 °C and 100 kPa with a velocity of 9.1 m/s. The exit area of the dryer is 18.7 cm ² , and the ambient temperature is 22 °C. The air is an ideal gas with gas constant $R = 0.287$ kJ/kg-K and isobaric specific heat $c_p = 1.005$ kJ/kg-K. If the change in potential energy is neglected, the second law efficiency (in %) of the dryer is _____ (rounded off to one decimal place).
Q.106	<p>A steam boiler contains saturated water vapour at 200 °C. After a certain period, the temperature of the boiler drops to 110 °C. Assume that all the valves of the boiler are closed and the energy is lost as heat to the surroundings. The ratio of mass of liquid to the mass of vapour is _____ (rounded off to two decimal places).</p> <p>Saturated volume of vapour phase at 200 °C = 0.127 m³/kg Saturated volume of vapour phase at 110 °C = 1.210 m³/kg Saturated volume of liquid phase at 110 °C = 0.001 m³/kg</p>

GATE 2025
IIT Roorkee

Q.107 Two Carnot heat engines (E1 and E2) are operating in series as shown in figure. Engine E1 receives heat from a reservoir at $T_H = 1600$ K and does work W_1 . Engine E2 receives heat from an intermediate reservoir at T , does work W_2 and rejects the rest to a reservoir at $T_L = 400$ K. Both the engines have identical thermal efficiencies. The temperature T (in K) of the intermediate reservoir is _____ (answer in integer).

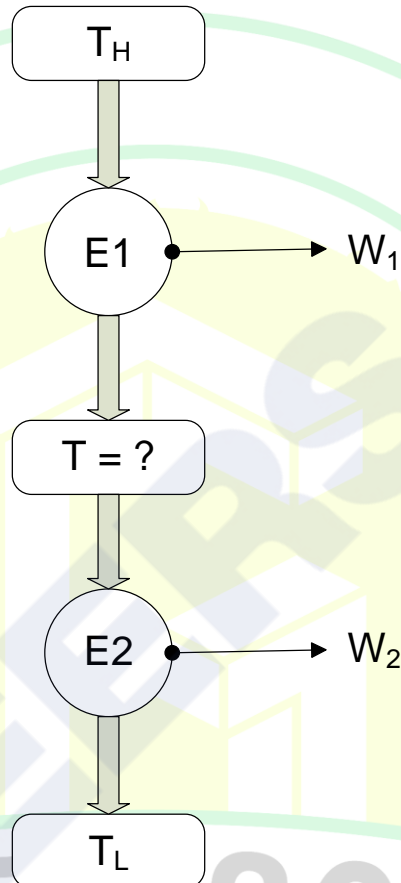

Q.108 A particular temperature scale is obtained according to the relation:

$$t = ae^{\alpha} + b$$

where a and b are constants, and t is in $^{\circ}\text{C}$.

The thermometric property as measured by the thermometer is α . The values of α at ice point and steam point are 6 and 9, respectively. The temperature (in $^{\circ}\text{C}$) which gives $\alpha = 7$ is _____ (rounded off to two decimal places).



Q.109	In a piston cylinder assembly, one kmol of an ideal gas is compressed from an initial state of 200 kPa and 400 K to a final state of 1 MPa and 400 K. If the surroundings are at 400 K, the minimum amount of work (in kJ/kmol) required for the compression process is _____ (<i>rounded off to two decimal places</i>). Use: Universal gas constant (R_u) = 8.314 kJ/kmol-K

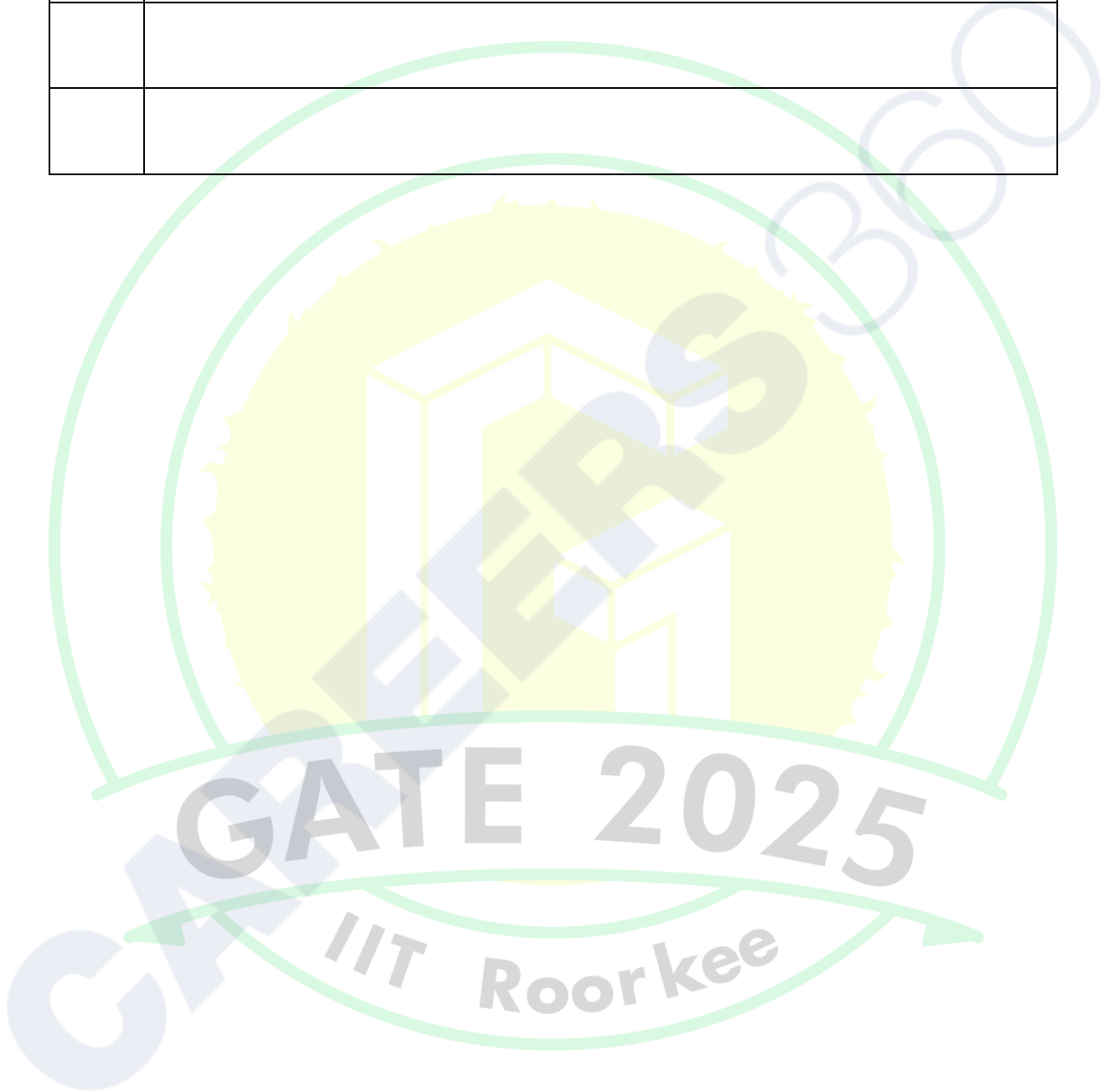



Polymer Science and Engineering (XE-F)

Q.110– Q.118 Carry ONE mark Each

Q.110	Which one of the following measures of viscosity is dimensionless?
(A)	Inherent viscosity
(B)	Reduced viscosity
(C)	Zero-shear viscosity
(D)	Specific viscosity
Q.111	Which one of the following permits the direct determination of intrinsic viscosity of a polymer solution for known molecular weight of the polymer?
(A)	Flory-Huggins equation
(B)	Newton's law of viscosity
(C)	Williams-Landel-Ferry equation
(D)	Mark-Houwink equation

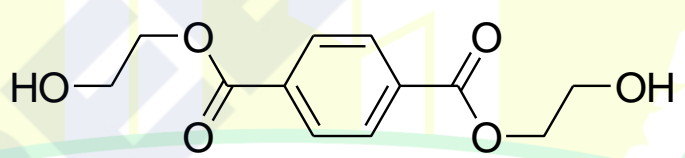
Q.112	Under which combination of conditions does the glass transition of a polymer increase?
(A)	Increase in molecular weight and increase in plasticizer content
(B)	Increase in plasticizer content and decrease in cross-linking
(C)	Increase in branching and decrease in inter-chain interactions
(D)	Increase in chain length and decrease in plasticizer content
Q.113	<p>In a polymer recycling plant, polymer “X” was depolymerized by glycolysis in the presence of ethylene glycol and a suitable catalyst. The glycolysis reaction yielded the following compound:</p>  <p>Identify the polymer “X” from the following options.</p>
(A)	Poly(ethylene terephthalate)
(B)	Polystyrene
(C)	Acrylonitrile butadiene styrene
(D)	Poly(vinyl chloride)

Q.114	Polymer “Z” has a high melting point and it decomposes even before it melts. Hence, it is usually dissolved and subsequently regenerated. Rayon is one such regenerated form. Identify the polymer “Z” from the following options.																				
(A)	Urea formaldehyde																				
(B)	Poly(vinyl carbazole)																				
(C)	Cellulose																				
(D)	Poly(vinyl acetate)																				
Q.115	Match the Product with the most appropriate Processing Technique employed. <table border="1" style="margin-left: auto; margin-right: auto;"> <thead> <tr> <th colspan="2">Product</th> <th colspan="2">Processing Technique</th> </tr> </thead> <tbody> <tr> <td>P</td> <td>Rainboots</td> <td>1</td> <td>Blow molding</td> </tr> <tr> <td>Q</td> <td>Disposable plastic cups</td> <td>2</td> <td>Calendering</td> </tr> <tr> <td>R</td> <td>Soft drink bottles</td> <td>3</td> <td>Rotational molding</td> </tr> <tr> <td>S</td> <td>Flexible films</td> <td>4</td> <td>Thermoforming</td> </tr> </tbody> </table>	Product		Processing Technique		P	Rainboots	1	Blow molding	Q	Disposable plastic cups	2	Calendering	R	Soft drink bottles	3	Rotational molding	S	Flexible films	4	Thermoforming
Product		Processing Technique																			
P	Rainboots	1	Blow molding																		
Q	Disposable plastic cups	2	Calendering																		
R	Soft drink bottles	3	Rotational molding																		
S	Flexible films	4	Thermoforming																		
(A)	P-3; Q-1; R-2; S-4																				
(B)	P-3; Q-4; R-1; S-2																				
(C)	P-1; Q-2; R-4; S-3																				
(D)	P-1; Q-3; R-4; S-2																				

Q.116	Crystallization is favored in polymer melts when the chain entanglement is _____ and only polymers with _____ molecular arrangement can crystallize.																				
(A)	maximum, ordered																				
(B)	minimum, random																				
(C)	maximum, random																				
(D)	minimum, ordered																				
Q.117	Match the Polymer with the most suitable Monomer combinations from which it is synthesized.																				
	<table border="1" data-bbox="392 1135 1315 1563"> <thead> <tr> <th colspan="2">Polymer</th> <th colspan="2">Monomer combinations</th> </tr> </thead> <tbody> <tr> <td>P</td> <td>Polyurethane</td> <td>1</td> <td>Maleic acid and propylene glycol</td> </tr> <tr> <td>Q</td> <td>Epoxy</td> <td>2</td> <td>Pyromellitic anhydride and <i>p,p'</i>-diamino diphenyl ether</td> </tr> <tr> <td>R</td> <td>Polyimide</td> <td>3</td> <td>Epichlorohydrin and bisphenol A</td> </tr> <tr> <td>S</td> <td>Polyester</td> <td>4</td> <td>Hexamethylene diisocyanate and tetramethylene glycol</td> </tr> </tbody> </table>	Polymer		Monomer combinations		P	Polyurethane	1	Maleic acid and propylene glycol	Q	Epoxy	2	Pyromellitic anhydride and <i>p,p'</i> -diamino diphenyl ether	R	Polyimide	3	Epichlorohydrin and bisphenol A	S	Polyester	4	Hexamethylene diisocyanate and tetramethylene glycol
Polymer		Monomer combinations																			
P	Polyurethane	1	Maleic acid and propylene glycol																		
Q	Epoxy	2	Pyromellitic anhydride and <i>p,p'</i> -diamino diphenyl ether																		
R	Polyimide	3	Epichlorohydrin and bisphenol A																		
S	Polyester	4	Hexamethylene diisocyanate and tetramethylene glycol																		
(A)	P-4; Q-3; R-2; S-1																				
(B)	P-4; Q-2; R-3; S-1																				
(C)	P-2; Q-1; R-4; S-3																				
(D)	P-2; Q-3; R-1; S-4																				



Q.118	Thermoplastic Polyurethane and Polyamide 6 both contain amide linkages, but when compared to Polyurethane, Polyamide 6 shows higher melting point due to _____.
(A)	Higher molecular rigidity
(B)	Higher degree of branching
(C)	Lower molecular rigidity
(D)	Lower degree of crosslinking

GATE 2025

IIT Roorkee

Q.119 – Q.131 Carry TWO marks Each

Q.119 Injection molding is typically used to make plastic parts. If the pressure at the gate is monitored as a function of time during the injection of a thermoplastic polymer, identify the profile that best describes this event.

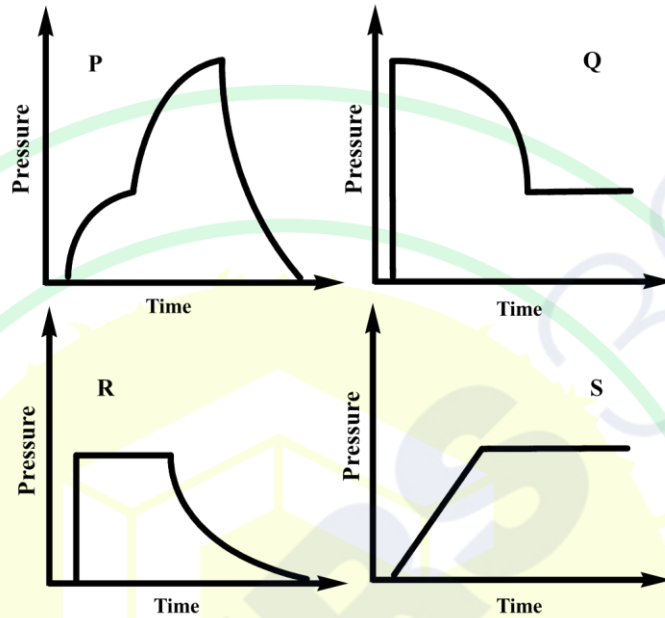

(A) Q

(B) R

(C) P

(D) S

<p>Q.120</p>	<p>The ‘unperturbed dimension’ of the polymer chain is represented as,</p> $(\overline{r_o^2})^{1/2} \propto \bar{l}(n)^{1/2}$ <p>where,</p> <p>$(\overline{r_o^2})^{1/2}$ = root-mean square end-to-end distance</p> <p>\bar{l} = average length of a segment</p> <p>n = number of segments in the chain</p> <p>Using the above information, root-mean square end-to-end distance of a branched polyethylene would be _____ when compared with that of the linear polyethylene of the same molecular weight and the same number of segments.</p>
(A)	Same
(B)	Higher
(C)	Lower
(D)	Exactly $\sqrt{2}$ times

Q.121

Choose the option(s) that correctly match(es) the **Zones** with their typical **Functions** in an industrial extruder.

Zones		Functions	
P	Feed zone	1	The melt acquires a constant flow rate
Q	Compression zone	2	No heating takes place
R	Metering zone	3	Polymer melts due to heat transferred from the heating element
		4	The helical flight of the screw imparts constant flow of the melt
		5	Polymer melts due to shear forces imparted by the screw

(A)

P-2; Q-5; R-1

(B)

P-2; Q-3; R-4

(C)

P-5; Q-1; R-2

(D)

P-2; Q-1; R-3

GATE 2025

IIT Roorkee

Q.122

During material testing, stress is applied from time t_i to t_f as shown below:

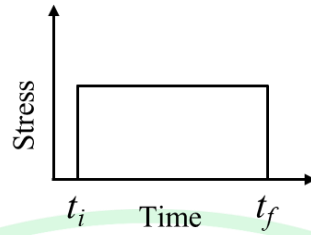

The corresponding strain responses for three different materials are shown in plots **P**, **Q** and **R**.

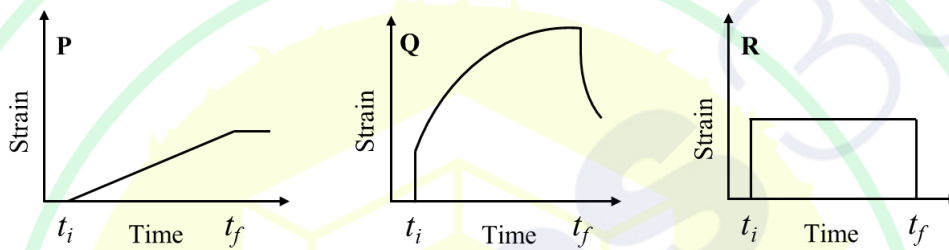

Choose the option(s) where the strain response is correctly mapped to its material class.

- (A) P- purely elastic; Q- purely viscous; R- viscoelastic
- (B) P- purely elastic; Q- viscoelastic; R- purely viscous
- (C) P- purely viscous; Q- purely elastic; R- viscoelastic
- (D) P- purely viscous; Q- viscoelastic; R- purely elastic

Q.123	Which option(s) correctly match(es) the Polymer property with its appropriate Units ?	Polymer property		Units		
		P	Hildebrand solubility parameter	1	Pa	
		Q	Loss modulus	2	J m^{-3}	
		R	Toughness	3	$(\text{MPa})^{1/2}$	
		S	Flexural strength	4	$\text{Kg m}^{-1} \text{s}^{-2}$	
(A)	P-2; Q-1; R-3; S-4					
(B)	P-2; Q-4; R-3; S-1					
(C)	P-3; Q-1; R-2; S-4					
(D)	P-3; Q-4; R-2; S-1					

GATE 2025

IIT Roorkee

Q.124	Which option(s) correctly match(es) the Class of additives used during polymer compounding with the corresponding Chemicals ?			
	Class of additives		Chemicals	
	P	Antioxidant	1	Phthalocyanine
	Q	Flame retardant	2	Di(2-ethylhexyl) phthalate
	R	Plasticizer	3	Tricresyl phosphate
	S	Colorant	4	Phenyl β -naphthyl amine
(A)	P-4; Q-3; R-2; S-1			
(B)	P-4; Q-3; R-3; S-1			
(C)	P-1; Q-2; R-4; S-2			
(D)	P-2; Q-3; R-1; S-2			

Q.125 In a set of copolymerization reactions, the following monomer reactivity ratios (r_1 and r_2) were found for different cases.

Case	r_1	r_2
I	0.1	10
II	0.003	0.02
III	3.4	5.6
IV	51	0.01

Which option(s) correctly identify/identifies the type of copolymerization corresponding to each **Case**?

(A) I - Ideal copolymerization

(B) II - Azeotropic copolymerization

(C) III - Block copolymerization

(D) IV - Alternating copolymerization

Q.126

The crystallization of a polymer can only proceed in a temperature range limited to glass transition temperature (T_g) on the lower side, and the equilibrium melting point (T_m^o) on the higher side. Around T_g , the mobility of the polymer chains is lower, while in the proximity of T_m^o , crystal nucleation is inhibited.

In a miscible polymer blend with only one component being crystalline, which option(s) correctly match(es) the **Temperature conditions** with **Events**?

Temperature conditions		Events	
P	The T_g of the amorphous component is lower than the crystallizable one	1	The temperature range over which crystallization can occur becomes smaller
Q	The T_g of the amorphous component is higher than the crystallizable one	2	Crystallization is inhibited
R	The blend T_g is higher than the T_m^o of the crystallizable one	3	The crystallization envelope ($T_m^o - T_g$) is widened
		4	Crystallization is favored

(A) P-3; Q-2; R-4

(B) P-3; Q-1; R-2

(C) P-4; Q-1; R-3

(D) P-4; Q-1; R-2

Q.127

The heat of polymerization of ethylene is 25 Kcal/mol. The amount of heat generated during the polymerization of 5.6 Kg polyethylene is _____ Kcal. (Round off to the nearest integer)

Q.128	<p>The density of an amorphous polymer is 0.77 g cm^{-3} and that of its crystalline counterpart is 0.99 g cm^{-3}. The density of a semi-crystalline sample of this polymer is found to be 0.88 g cm^{-3}.</p> <p>The degree of crystallinity (on weight basis) of this semi-crystalline sample is _____. (Round off to two decimal places)</p>
Q.129	<p>Titration was used to determine the molar mass of two linear monodisperse polymers A and B. Both the polymers possess the same repeat unit and contain acid end-groups. First, 10 g of polymer A was titrated with 5 mL of a 0.1 M alkali solution. In a separate experiment, 5 g of polymer B was titrated with 5 mL of a 0.1 M alkali solution. All of the alkali solution reacted with the acid end-groups present in both polymer A and polymer B.</p> <p>The ratio of the molar mass of A to the molar mass of B is _____. (Round off to one decimal place)</p>
Q.130	<p>A unidirectional composite of a resin is prepared with continuous fibers, wherein the volume fraction of the fiber in the composite is 0.7. Assume that the resin has a modulus of 9 GPa and the fiber has a modulus of 90 GPa. A sample of this composite, possessing a breadth of 4 mm and a thickness of 1 mm, is subjected to a uniaxial tensile test along the direction of the fiber.</p> <p>Corresponding to a strain of 0.5 %, the force applied on the sample is _____ N. (Round off to the nearest integer)</p>



Q.131	<p>A rubber contains 70 wt% butadiene (molar mass = 54 g/mol), 20 wt% isoprene (molar mass = 68 g/mol), 5 wt% sulfur and 5 wt% carbon black. Assume that all the sulfur is present in crosslinks.</p> <p>If each sulfide crosslink contains an average of two sulfur atoms, the percentage of possible crosslinks that are joined by vulcanization is _____. (Round off to one decimal place)</p>

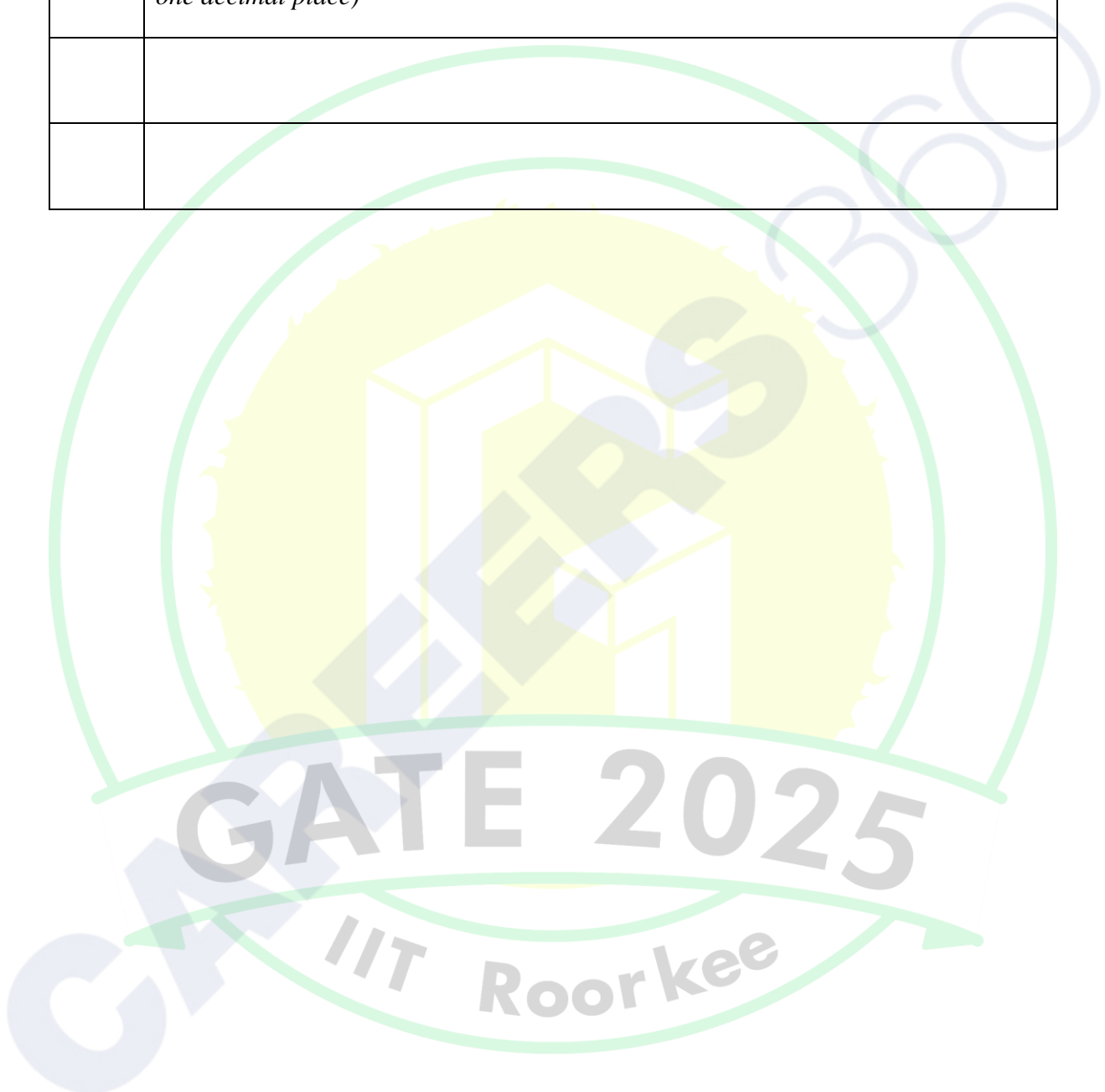



Food Technology (XE-G)

Q.132– Q.140 Carry ONE mark Each

Q.132	Which of the following contains the phytonutrient allicin?
(A)	Grape
(B)	Cauliflower
(C)	Garlic
(D)	Chilli
Q.133	Which mold is responsible for the characteristic blue marbling in blue-veined cheese?
(A)	<i>Rhizopus oryzae</i>
(B)	<i>Penicillium roqueforti</i>
(C)	<i>Aspergillus niger</i>
(D)	<i>Penicillium camemberti</i>



Q.134	Which genus of bacteria does NOT have cell wall?
(A)	<i>Lactobacillus</i>
(B)	<i>Staphylococcus</i>
(C)	<i>Mycoplasma</i>
(D)	<i>Escherichia</i>
Q.135	Which of the following pigment does NOT have pro-vitamin A activity?
(A)	β -Carotene
(B)	β -Cryptoxanthin
(C)	Lycopene
(D)	α -Carotene



Q.136	Identify the analysis that must be performed FIRST to judge ‘cleanliness’ of spice/herb powders.
(A)	Acid-insoluble ash content
(B)	Pesticide residue levels
(C)	Volatile oil content
(D)	Mycotoxin levels
Q.137	If there is a delay in oil extraction after bran is separated from the brown rice, the quality of rice bran oil deteriorates. Identify the suitable CAUSE and EFFECT for the deterioration in oil quality.
(A)	Lipase activity; increase in FFA
(B)	Oil hydrolysis; decrease in FFA
(C)	Lipase activity; decrease in FFA
(D)	Bran stabilization; decrease in lipase activity

Q.138	Among the following, which is/are the process(es) that lead to generation of new fats from existing ones?
(A)	Transesterification
(B)	Degumming
(C)	Hydrogenation
(D)	Winterization
Q.139	The true density and bulk density of wheat grains are 1280 kg/m^3 and 740 kg/m^3 , respectively. The porosity of the grains is _____. (<i>rounded off to 2 decimal places</i>)
Q.140	Potato slices weighing 50 kg is dried from 60% moisture content (wet basis) to 5% moisture content (dry basis). The amount of dried potato slices obtained (in kg) is _____. (<i>Answer in integer</i>)

Q.141 – Q.153 Carry TWO marks Each

Q.141	Identify the gas composition (in percent) suitable for packaging cured meat under MAP conditions.
(A)	$O_2 = 0; CO_2 = 50; N_2 = 50$
(B)	$O_2 = 50; CO_2 = 0; N_2 = 50$
(C)	$O_2 = 0; CO_2 = 0; N_2 = 100$
(D)	$O_2 = 50; CO_2 = 50; N_2 = 0$
Q.142	Which of the following sequence of events occurs during formation of egg-white gel?
	Assume: P_N : Native protein; P_D : Denatured protein; P_A : Aggregated protein; P_G : Protein gel \rightarrow : forward reaction; \leftrightarrow : reversible reaction; Δ : heating; ∇ : cooling
(A)	$P_N \xleftrightarrow{\Delta} P_D \xleftrightarrow{\nabla} P_A \xleftrightarrow{\nabla} P_G$
(B)	$P_N \xleftrightarrow{\Delta} P_D \xrightarrow{\Delta} P_A \xrightarrow{\Delta} P_G$
(C)	$P_N \xleftrightarrow{\Delta} P_D \xrightarrow{\nabla} P_G$
(D)	$P_N \leftrightarrow P_A \xrightarrow{\Delta} P_G$

Q.143	In canning and retorting of foods, which of the following is the correct expression of Ball process time (B)? Assume: t_p = processor's process time; t_c = come-up time
(A)	$B = t_p + 0.42 t_c$
(B)	$B = t_p + 0.30 t_c$
(C)	$B = t_p + 0.50 t_c$
(D)	$B = t_p + 0.25 t_c$
Q.144	Which of the following is the most suitable flexible packaging laminate for dry fruits?
(A)	PET/LDPE
(B)	PS/LDPE
(C)	BOPP/LDPE
(D)	Nylon/LDPE

Q.145	Identify the CORRECT sequence of operations for dressing of poultry.
(A)	Slaughtering and bleeding → scalding → defeathering → eviscerating → chilling
(B)	Slaughtering and bleeding → defeathering → scalding → eviscerating → chilling
(C)	Slaughtering and bleeding → eviscerating → defeathering → scalding → chilling
(D)	Slaughtering and bleeding → defeathering → eviscerating → scalding → chilling
Q.146	Which of the following statement(s) is/are TRUE for a package of gamma-irradiated (7.5 kGy) whole chicken?
(A)	Nutritional quality of the product deteriorates after irradiation.
(B)	Spores of <i>C. botulinum</i> can survive in the irradiated product.
(C)	'Radura' symbol does not ensure safety of the irradiated product for consumption.
(D)	Energy needed for the irradiation process is much higher than that required for freezing of the product.

Q.147	Match the following food products in Column I with their corresponding processes in Column II.																				
	<table border="1"> <thead> <tr> <th colspan="2">Column I</th> <th colspan="2">Column II</th> </tr> </thead> <tbody> <tr> <td>P</td> <td>Idli</td> <td>1</td> <td>Baking</td> </tr> <tr> <td>Q</td> <td>Parboiled rice</td> <td>2</td> <td>Fermentation</td> </tr> <tr> <td>R</td> <td>Soda beverage</td> <td>3</td> <td>Gelatinization</td> </tr> <tr> <td>S</td> <td>Cookies</td> <td>4</td> <td>Carbonation</td> </tr> </tbody> </table>	Column I		Column II		P	Idli	1	Baking	Q	Parboiled rice	2	Fermentation	R	Soda beverage	3	Gelatinization	S	Cookies	4	Carbonation
Column I		Column II																			
P	Idli	1	Baking																		
Q	Parboiled rice	2	Fermentation																		
R	Soda beverage	3	Gelatinization																		
S	Cookies	4	Carbonation																		
(A)	P-2;Q-3;R-4;S-1																				
(B)	P-3;Q-2;R-4;S-1																				
(C)	P-2;Q-4;R-1;S-3																				
(D)	P-2;Q-3;R-1;S-4																				
Q.148	Which of the following is/are inhibitor(s) of enzymatic browning in peeled potatoes?																				
(A)	Citric acid																				
(B)	EDTA																				
(C)	Mannitol																				
(D)	Ascorbic acid																				

Q.149	Match the following enzymes in Column I with their applications in Column II.																				
	<table border="1"> <thead> <tr> <th colspan="2">Column I</th> <th colspan="2">Column II</th> </tr> </thead> <tbody> <tr> <td>P</td> <td>β-Glucanase</td> <td>1</td> <td>Fruit juice clarification</td> </tr> <tr> <td>Q</td> <td>α- and β-Amylases</td> <td>2</td> <td>Bread making</td> </tr> <tr> <td>R</td> <td>Pectinase</td> <td>3</td> <td>Meat tenderization</td> </tr> <tr> <td>S</td> <td>Papain</td> <td>4</td> <td>Brewing</td> </tr> </tbody> </table>	Column I		Column II		P	β -Glucanase	1	Fruit juice clarification	Q	α - and β -Amylases	2	Bread making	R	Pectinase	3	Meat tenderization	S	Papain	4	Brewing
Column I		Column II																			
P	β -Glucanase	1	Fruit juice clarification																		
Q	α - and β -Amylases	2	Bread making																		
R	Pectinase	3	Meat tenderization																		
S	Papain	4	Brewing																		
(A)	P-3;Q-1;R-2;S-4																				
(B)	P-4;Q-2;R-1;S-3																				
(C)	P-2;Q-4;R-1;S-3																				
(D)	P-1;Q-2;R-3;S-4																				
Q.150	The F_{121} value of a known microorganism with Z value of 11 °C is 2.4 min for 99.9999% inactivation. For a 12D inactivation of the said microorganism at 143 °C, the F value (in min) is _____. (rounded off to 3 decimal places)																				
Q.151	Consider that specific heat (0 to 50 °C) of water, water vapour and air remains constant: 4.48, 1.88 and 1.0 kJ/ (kg °C), respectively. Assuming, the heat energy required to convert 1 kg of water to water vapour at 0 °C is 2000 kJ, the enthalpy (in kJ/ kg dry air) of atmospheric air containing 0.05 kg water vapour per kg dry air at 50 °C is _____.(rounded off to 1 decimal place)																				

Q.152	A fruit juice is concentrated using an ultrafiltration membrane. A feed stream at 10 kg/min with 6% total solids (by weight) is increased to 20% total solids (by weight). The membrane tube has 10 cm inside diameter and the pressure difference across the membrane is 2000 kPa. If the permeability constant of the membrane is 5×10^{-5} kg water/ (m ² kPa s), the length of membrane tube (in m) is _____. (rounded off to 2 decimal places)
Q.153	In a typical grinding operation, 80% of the feed material passes through a sieve opening of 4.75 mm; whereas, 80% of the ground product passes through 0.5 mm opening. If the power required to grind 2 tonnes/h of the feed material is 3.8 kW, the work index of the material is _____. (rounded off to 2 decimal places)

GATE 2025

IIT Roorkee



Atmospheric and Oceanic Sciences (XE-H)

Q.154– Q.162 Carry ONE mark Each

Q.154	During which of the following times of the day is the 2 m air temperature usually the lowest at a tropical location?
(A)	At sunrise
(B)	At noon
(C)	At sunset
(D)	At midnight
Q.155	At which of the following locations in the atmosphere is the anvil of a towering cumulonimbus cloud usually located?
(A)	Top of the surface layer
(B)	Top of the boundary layer
(C)	Tropopause
(D)	Stratopause

Q.156	Which one of the following is the main reason why tropical cyclones rarely form over the Bay of Bengal during the summer monsoon season?
(A)	Strong vertical wind shear.
(B)	Weak low-level relative vorticity.
(C)	Dry mid-troposphere.
(D)	Stable atmosphere.
Q.157	Which one of the following is the main cause of the land-sea temperature contrast that drives phenomena like sea breeze and the Indian summer monsoon?
(A)	Difference in the cloud cover between the land and the sea.
(B)	Difference in the albedo between the land and the sea.
(C)	Difference in the specific heat capacities between the land and the sea.
(D)	Difference in the surface roughness between the land and the sea.

Q.158	The directions of the South Pacific Subtropical Gyre and the North Atlantic Subtropical Gyre are _____ and _____, respectively.
(A)	clockwise; counter-clockwise
(B)	counter-clockwise; clockwise
(C)	clockwise; clockwise
(D)	counter-clockwise; counter-clockwise
Q.159	The time period of the inertial oscillation at a location R is 1.5 times that of a particle moving at a speed of 0.5 m s^{-1} at a location S (87°E , 45°S). Which of the following is the latitude of location R? (<i>Round off to the nearest integer</i>)
(A)	45°N
(B)	67°S
(C)	28°N
(D)	50°S

Q.160	Which of the following Period(s) correspond(s) to wind waves?
(A)	5 seconds
(B)	20 seconds
(C)	6 hours
(D)	12 hours
Q.161	Accumulated rainfall is often measured in mm. If the density of rain water is 1000 kg m^{-3} then, one mm of rain is equal to _____ kg m^{-2} of rain. (<i>in integer</i>).
Q.162	Acceleration due to Coriolis force of a water parcel at a location P (67°E , 20°N) moving with a speed of 0.35 m s^{-1} is _____ $\times 10^{-5} \text{ m s}^{-2}$. (<i>Round off to two decimal places</i>) [Assume the angular velocity of the Earth is $7.3 \times 10^{-5} \text{ s}^{-1}$.]

Q.163 – Q.175 Carry TWO marks Each

Q.163	A rotating weather system has a tangential velocity of 100 m s^{-1} , diameter of 1 km, and located at a latitude where the Coriolis parameter is 10^{-4} s^{-1} . Which one of the following statements is true about this weather system?
(A)	It is in geostrophic balance.
(B)	It is in gradient wind balance.
(C)	It is a high-pressure system.
(D)	It is in cyclostrophic balance.

GATE 2025

IIT Roorkee

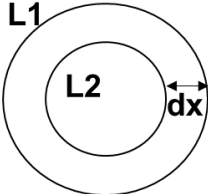
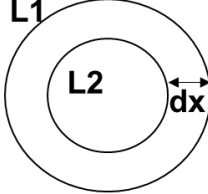
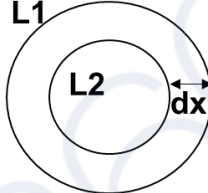
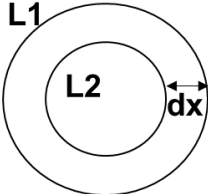
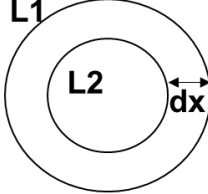
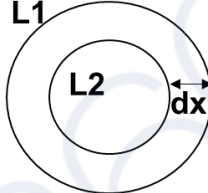
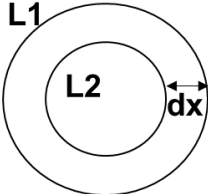
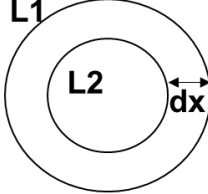
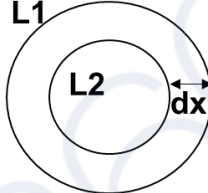
Q.164	<p>The sea surface height concentric isolines (L1 and L2 in cm) and the distance between them (dx in km) for three different eddies at the same latitude are given in the figure below. (<i>The figures are not to scale.</i>)</p>			
	<table border="1" style="width: 100%; text-align: center;"> <tr> <td data-bbox="320 465 671 860"> <p>(i)</p>  <p>L1= 20 cm, L2= 30 cm, dx =200 km</p> </td> <td data-bbox="671 465 1023 860"> <p>(ii)</p>  <p>L1= 10 cm, L2= 20 cm, dx =300 km</p> </td> <td data-bbox="1023 465 1374 860"> <p>(iii)</p>  <p>L1= 5 cm, L2= 15 cm, dx =100 km</p> </td> </tr> </table> <p>Which one of the following orders is correct about the magnitudes of the geostrophic currents within the isolines?</p>	<p>(i)</p>  <p>L1= 20 cm, L2= 30 cm, dx =200 km</p>	<p>(ii)</p>  <p>L1= 10 cm, L2= 20 cm, dx =300 km</p>	<p>(iii)</p>  <p>L1= 5 cm, L2= 15 cm, dx =100 km</p>
<p>(i)</p>  <p>L1= 20 cm, L2= 30 cm, dx =200 km</p>	<p>(ii)</p>  <p>L1= 10 cm, L2= 20 cm, dx =300 km</p>	<p>(iii)</p>  <p>L1= 5 cm, L2= 15 cm, dx =100 km</p>		
(A)	(i) > (ii) > (iii)			
(B)	(ii) > (iii) > (i)			
(C)	(iii) > (i) > (ii)			
(D)	(iii) > (ii) > (i)			

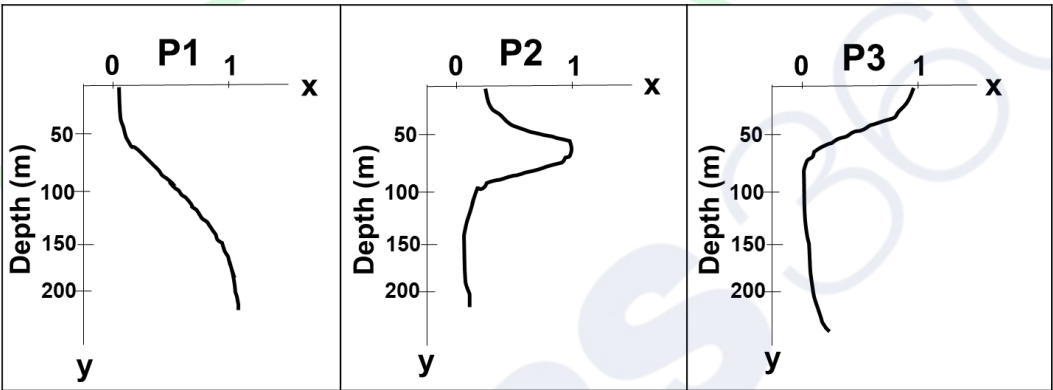
Q.165	<p>The vertical (depth) profiles for three parameters P1, P2, and P3 in the northern Indian Ocean are given in the figure below. The values along the x-axis are the normalized values of the parameters and y-axis is the depth (m).</p>
<div style="display: flex; justify-content: space-around; align-items: flex-start;">  </div> <p>Identify the parameters P1, P2, and P3 from the options given below.</p>	
(A)	P1 : Dissolved Oxygen; P2 : Nitrate; P3 : Chlorophyll
(B)	P1 : Nitrate; P2 : Chlorophyll; P3 : Dissolved Oxygen
(C)	P1 : Dissolved Oxygen; P2 : Chlorophyll; P3 : Nitrate
(D)	P1 : Chlorophyll; P2 : Nitrate; P3 : Dissolved Oxygen

Q.166	The zonal gradient of meridional current and the meridional gradient of zonal current is $-0.3 \times 10^{-3} \text{ s}^{-1}$ and $0.3 \times 10^{-3} \text{ s}^{-1}$, respectively, at a location P (87°E , 15°N). Which one of the following best explains the nature of the flow?
(A)	The flow is non-divergent in nature.
(B)	The flow is non-rotational in nature.
(C)	The flow is counter-clockwise in nature.
(D)	The flow is clockwise in nature.
Q.167	The north-Atlantic deep-water is associated with _____.
(A)	low temperature and low salinity
(B)	high temperature and high salinity
(C)	high temperature and low salinity
(D)	low temperature and high salinity

Q.168	<p>Which of the following is the correct form of the mass divergence form of the continuity equation for a compressible fluid?</p> <p>[In the given equations, ρ is the density and \mathbf{v} the three dimensional velocity vector of the fluid.]</p>
	<p>(i) $\frac{\partial \rho}{\partial t} + \nabla \times (\rho \mathbf{v}) = 0$</p> <p>(ii) $\frac{\partial \rho}{\partial t} + \nabla \cdot (\rho \mathbf{v}) = 0$</p> <p>(iii) $\frac{\partial \mathbf{v}}{\partial t} + \rho \cdot \nabla \mathbf{v} = 0$</p> <p>(iv) $\frac{\partial \rho}{\partial t} + \mathbf{v} \cdot \nabla \rho = 0$</p>
(A)	(i) and (ii)
(B)	(ii)
(C)	(i) and (iv)
(D)	(iii)

Q.169 In the figures given below, **L** and **H** indicate low and high pressure centers, respectively; **PGF**, **CoF** and **CeF** indicate Pressure Gradient Force, Coriolis Force and Centrifugal Force, respectively; **V** is Velocity.

[The arrows indicate only the directions but not the magnitudes of the forces and velocity.]

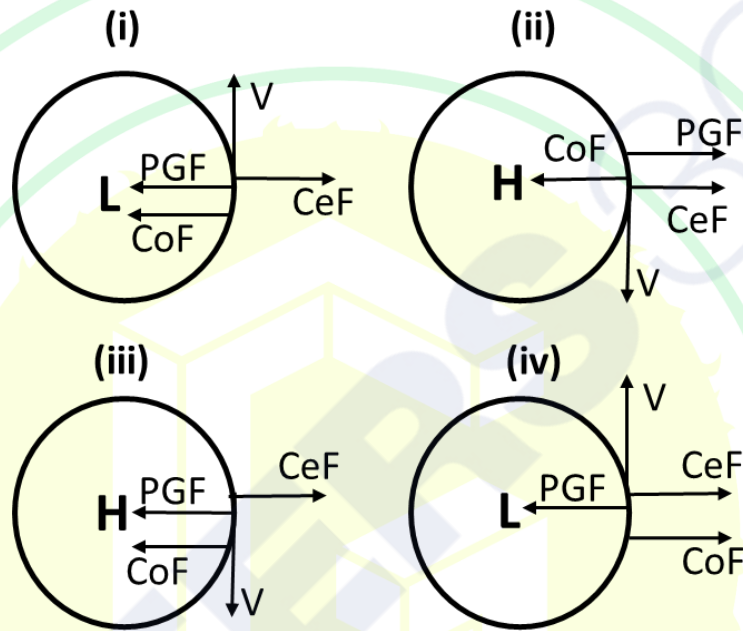

Which of the following is/are the correct representation(s) of the directions of various forces and velocity in the gradient wind balance in the northern hemisphere?

(A) (i)

(B) (ii)

(C) (iii)

(D) (iv)

Q.170	<p>One kg of dry air at 15 °C is isothermally compressed to one-tenth of its initial volume. The work done on the system is _____ kJ. (Round off to the nearest integer.)</p> <p>[Assume that the gas constant for dry air is $287 \times 10^5 \text{ J K}^{-1} \text{ kg}^{-1}$.]</p>
Q.171	<p>In hot weather, a human body cools by the evaporation of sweat from its skin. The amount of water that must evaporate to cool the body by 1 °C is _____ % of the body mass. (Round off to two decimal places.)</p> <p>[Assume that latent heat of vaporization of water is $2.25 \times 10^6 \text{ J kg}^{-1}$ and specific heat capacities of both human body and liquid water is $4.2 \times 10^3 \text{ J K}^{-1} \text{ kg}^{-1}$.]</p>
Q.172	<p>A floating hot air balloon with volume 1000 m^3 and gross mass (excluding the air in the balloon) 100 kg is in hydrostatic balance where the external air temperature is 10 °C and density is 1 kg m^{-3}. The temperature of the air inside the balloon is _____ °C. (Round off to the nearest integer.)</p>
Q.173	<p>The solar constant for the Earth is 1368 W m^{-2}. Consider the planet Jupiter whose mass is 320 times that of the Earth and distance from the Sun is 5.2 times that of the Earth. The solar constant for Jupiter is _____ W m^{-2}. (Round off to the nearest integer.)</p>

Q.174	<p>A column of air mass extending from surface to a height of 10 km moving eastward along 30°N strikes a north-south oriented mountain range. While crossing the mountain range, the air mass acquires a relative vorticity of $-3.65 \times 10^{-5} \text{ s}^{-1}$ at the top. If the air mass maintains the same latitude and conserves potential vorticity, the height of the mountain range is _____ km. (Round off to the nearest integer.)</p> <p>[Assume the angular velocity of the Earth is $7.3 \times 10^{-5} \text{ s}^{-1}$ and initial relative vorticity is zero.]</p>												
Q.175	<p>The Sea Surface Temperature, Air Temperature and 10 m Wind Speed at the locations P and Q are given in the table below.</p> <p>[Assume the density of air, specific heat capacity, and sensible heat transfer constant are the same at both locations.]</p>												
	<table border="1" data-bbox="320 1099 1347 1317"> <thead> <tr> <th>Location</th> <th>Sea Surface temperature ($^\circ\text{C}$)</th> <th>Air temperature ($^\circ\text{C}$)</th> <th>Wind Speed at 10m (m s^{-1})</th> </tr> </thead> <tbody> <tr> <td>P</td> <td>28</td> <td>35</td> <td>4</td> </tr> <tr> <td>Q</td> <td>30</td> <td>32</td> <td>7</td> </tr> </tbody> </table> <p>The sensible heat (SH) flux at the locations P and Q are SH_P and SH_Q, respectively. The value of $\left(\frac{\text{SH}_P}{\text{SH}_Q}\right)$ is _____. (in integer)</p>	Location	Sea Surface temperature ($^\circ\text{C}$)	Air temperature ($^\circ\text{C}$)	Wind Speed at 10m (m s^{-1})	P	28	35	4	Q	30	32	7
Location	Sea Surface temperature ($^\circ\text{C}$)	Air temperature ($^\circ\text{C}$)	Wind Speed at 10m (m s^{-1})										
P	28	35	4										
Q	30	32	7										



GRADUATE APTITUDE TEST IN ENGINEERING 2025

अभियांत्रिकी स्नातक अभिक्षमता परीक्षा २०२५

Organising Institute: INDIAN INSTITUTE OF TECHNOLOGY ROORKEE



Answer Key for Engineering Sciences (XE)

Q. No.	Session	Q. Type	Section	Key/Range	Marks
1	8	MCQ	GA	D	1
2	8	MCQ	GA	B	1
3	8	MCQ	GA	B	1
4	8	MCQ	GA	C	1
5	8	MCQ	GA	A	1
6	8	MCQ	GA	A	2
7	8	MCQ	GA	B	2
8	8	MCQ	GA	C	2
9	8	MCQ	GA	A	2
10	8	MCQ	GA	C	2
11	8	MCQ	XE-A	D	1
12	8	MCQ	XE-A	A	1
13	8	MCQ	XE-A	D	1
14	8	MCQ	XE-A	A	1
15	8	MCQ	XE-A	A	1
16	8	NAT	XE-A	5 to 5	1
17	8	NAT	XE-A	2 to 2	1
18	8	MCQ	XE-A	B	2
19	8	MCQ	XE-A	D	2
20	8	MSQ	XE-A	A;C	2
21	8	NAT	XE-A	0.68 to 0.73	2
22	8	MCQ	XE-B	A	1
23	8	MCQ	XE-B	A	1
24	8	MCQ	XE-B	B	1
25	8	MCQ	XE-B	A	1
26	8	MCQ	XE-B	A	1
27	8	MCQ	XE-B	B	1
28	8	MCQ	XE-B	D	1
29	8	MCQ	XE-B	A	1
30	8	MCQ	XE-B	A	1

31	8	MCQ	XE-B	A	2
32	8	MCQ	XE-B	A	2
33	8	MCQ	XE-B	A	2
34	8	MCQ	XE-B	A	2
35	8	MCQ	XE-B	C	2
36	8	NAT	XE-B	71 to 71	2
37	8	NAT	XE-B	4.80 to 5.00	2
38	8	NAT	XE-B	1 to 1	2
39	8	NAT	XE-B	0.50 to 0.60	2
40	8	NAT	XE-B	-0.32 to -0.32	2
41	8	NAT	XE-B	0.95 to 1.05	2
42	8	NAT	XE-B	0.85 to 0.90	2
43	8	NAT	XE-B	0.85 to 1.28	2
44	8	MCQ	XE-C	B	1
45	8	MCQ	XE-C	A	1
46	8	MCQ	XE-C	A	1
47	8	MCQ	XE-C	A	1
48	8	MSQ	XE-C	C;D	1
49	8	MSQ	XE-C	A;C;D	1
50	8	MSQ	XE-C	A;B;C	1
51	8	NAT	XE-C	1 to 1	1
52	8	NAT	XE-C	0.60 to 0.70	1
53	8	MCQ	XE-C	A	2
54	8	MCQ	XE-C	D	2
55	8	MCQ	XE-C	A	2
56	8	MCQ	XE-C	B	2
57	8	NAT	XE-C	1.4 to 1.8	2
58	8	NAT	XE-C	1.3 to 1.5	2
59	8	NAT	XE-C	4.20 to 4.60	2
60	8	NAT	XE-C	1.00 to 1.20	2
61	8	NAT	XE-C	0.35 to 0.50	2
62	8	NAT	XE-C	0.90 to 1.30	2
63	8	NAT	XE-C	0.8 to 1.2	2
64	8	NAT	XE-C	0.19 to 0.27	2
65	8	NAT	XE-C	2.0 to 2.6	2
66	8	MCQ	XE-D	D	1
67	8	MCQ	XE-D	B	1
68	8	MCQ	XE-D	C	1

69	8	MCQ	XE-D	A	1
70	8	MCQ	XE-D	D	1
71	8	MSQ	XE-D	B;C	1
72	8	NAT	XE-D	490 to 494	1
73	8	NAT	XE-D	0.40 to 0.40	1
74	8	NAT	XE-D	400 to 400	1
75	8	MCQ	XE-D	A	2
76	8	MCQ	XE-D	C	2
77	8	MCQ	XE-D	B	2
78	8	MCQ	XE-D	D	2
79	8	MCQ	XE-D	C	2
80	8	MSQ	XE-D	A;B;D	2
81	8	MSQ	XE-D	A;C	2
82	8	NAT	XE-D	603.5 to 607.5	2
83	8	NAT	XE-D	1.46 to 1.50	2
84	8	NAT	XE-D	4.9 to 5.1	2
85	8	NAT	XE-D	3.43 to 3.47	2
86	8	NAT	XE-D	392 to 394	2
87	8	NAT	XE-D	10 to 10	2
88	8	MCQ	XE-E	B	1
89	8	MCQ	XE-E	C	1
90	8	MCQ	XE-E	A	1
91	8	MCQ	XE-E	C	1
92	8	MCQ	XE-E	C	1
93	8	MCQ	XE-E	A	1
94	8	NAT	XE-E	0.030 to 0.034	1
95	8	NAT	XE-E	80 to 80	1
96	8	NAT	XE-E	773 to 776	1
97	8	MCQ	XE-E	B	2
98	8	MSQ	XE-E	A;D	2
99	8	MSQ	XE-E	C;D	2
100	8	NAT	XE-E	6.9 to 7.2	2
101	8	NAT	XE-E	63 to 66	2
102	8	NAT	XE-E	11.5 to 12.0	2
103	8	NAT	XE-E	1515 to 1545	2
104	8	NAT	XE-E	1.30 to 1.38	2
105	8	NAT	XE-E	8.9 to 9.4	2
106	8	NAT	XE-E	8.1 to 8.9	2

107	8	NAT	XE-E	800 to 800	2
108	8	NAT	XE-E	8.9 to 9.1	2
109	8	NAT	XE-E	5300 to 5400	2
110	8	MCQ	XE-F	D	1
111	8	MCQ	XE-F	D	1
112	8	MCQ	XE-F	D	1
113	8	MCQ	XE-F	A	1
114	8	MCQ	XE-F	C	1
115	8	MCQ	XE-F	B	1
116	8	MCQ	XE-F	D	1
117	8	MCQ	XE-F	A	1
118	8	MCQ	XE-F	A	1
119	8	MCQ	XE-F	C	2
120	8	MSQ	XE-F	C	2
121	8	MSQ	XE-F	A;B	2
122	8	MSQ	XE-F	D	2
123	8	MSQ	XE-F	C;D	2
124	8	MSQ	XE-F	A;B	2
125	8	MSQ	XE-F	A;C	2
126	8	MSQ	XE-F	B;D	2
127	8	NAT	XE-F	4975 to 5025	2
128	8	NAT	XE-F	0.52 to 0.60	2
129	8	NAT	XE-F	2.0 to 2.0	2
130	8	NAT	XE-F	1300 to 1330	2
131	8	NAT	XE-F	9.4 to 10.2	2
132	8	MCQ	XE-G	C	1
133	8	MCQ	XE-G	B	1
134	8	MCQ	XE-G	C	1
135	8	MCQ	XE-G	C	1
136	8	MCQ	XE-G	A	1
137	8	MCQ	XE-G	A	1
138	8	MSQ	XE-G	A;C	1
139	8	NAT	XE-G	0.40 to 0.44	1
140	8	NAT	XE-G	21.0 to 21.0	1
141	8	MCQ	XE-G	A	2
142	8	MCQ	XE-G	B	2
143	8	MCQ	XE-G	A	2
144	8	MCQ	XE-G	C	2

145	8	MCQ	XE-G	A	2
146	8	MSQ	XE-G	B;C	2
147	8	MSQ	XE-G	A	2
148	8	MSQ	XE-G	A;B;D	2
149	8	MSQ	XE-G	B;C	2
150	8	NAT	XE-G	0.046 to 0.050	2
151	8	NAT	XE-G	152.0 to 156.0	2
152	8	NAT	XE-G	3.65 to 3.75	2
153	8	NAT	XE-G	6.25 to 6.32	2
154	8	MCQ	XE-H	A	1
155	8	MCQ	XE-H	C	1
156	8	MCQ	XE-H	A	1
157	8	MCQ	XE-H	C	1
158	8	MCQ	XE-H	B	1
159	8	MCQ	XE-H	C	1
160	8	MSQ	XE-H	A;B	1
161	8	NAT	XE-H	1 to 1	1
162	8	NAT	XE-H	1.72 to 1.78	1
163	8	MCQ	XE-H	D	2
164	8	MCQ	XE-H	C	2
165	8	MCQ	XE-H	B	2
166	8	MCQ	XE-H	D	2
167	8	MCQ	XE-H	D	2
168	8	MCQ	XE-H	B	2
169	8	MSQ	XE-H	B;D	2
170	8	NAT	XE-H	189 to 191	2
171	8	NAT	XE-H	0.18 to 0.19	2
172	8	NAT	XE-H	40 to 42	2
173	8	NAT	XE-H	50 to 52	2
174	8	NAT	XE-H	5 to 5	2
175	8	NAT	XE-H	2 to 2	2