

CAREERS 360

PRACTICE **Series**

BITSAT

**Memory Based
Questions**

BITSAT 2024 Question Paper

Time Allowed :3 hours	Maximum Marks :390	Total questions :130
------------------------------	---------------------------	-----------------------------

General Instructions

Read the following instructions very carefully and strictly follow them:

1. **Mode:** Computer-based online test
2. **Duration:** 3 hours (180 minutes)
3. **Sections:** The exam consists of four parts:
 - (a) Part I: Physics (30 questions)
 - (b) Part II: Chemistry (30 questions)
 - (c) Part III: English Proficiency (10 questions) and Logical Reasoning (20 questions)
 - (d) Part IV: Mathematics (40 questions) or Biology (for B.Pharm candidates)
4. **Total Marks:** 390
5. **Marking Scheme:** Each correct answer awards 3 marks, and 1 mark is deducted for each incorrect answer
6. **Subjects:**
 - (a) Physics: Mechanics, Electromagnetism, Thermodynamics, Modern Physics
 - (b) Chemistry: Organic, Inorganic, and Physical Chemistry
 - (c) Mathematics: Calculus, Algebra, Geometry (or Biology for B.Pharm candidates)
 - (d) English Proficiency: Reading Comprehension, Vocabulary
 - (e) Logical Reasoning: Analytical and Problem-solving skills

Physics

1. You measure two quantities as $A = 1.0\text{ m} \pm 0.2\text{ m}$, $B = 2.0\text{ m} \pm 0.2\text{ m}$. We should report the correct value for \sqrt{AB} as:

- (A) $1.4\text{ m} \pm 0.4\text{ m}$
 - (B) $1.41\text{ m} \pm 0.15\text{ m}$
 - (C) $1.4\text{ m} \pm 0.3\text{ m}$
 - (D) $1.4\text{ m} \pm 0.2\text{ m}$
-

2. The dimensional formula of latent heat is:

- (A) $[M^0LT^{-2}]$
 - (B) $[MLT^{-2}]$
 - (C) $[M^0L^2T^{-2}]$
 - (D) $[ML^2T^{-2}]$
-

3. The dimensions of the coefficient of self-inductance are:

- (A) $[ML^2T^{-2}A^{-2}]$
 - (B) $[ML^2T^{-2}A^{-1}]$
 - (C) $[MLT^{-2}A^{-2}]$
 - (D) $[MLT^{-2}A^{-1}]$
-

4. A particle is moving in a straight line. The variation of position x as a function of time t is given as:

$$x = t^3 - 6t^2 + 20t + 15$$

The velocity of the body when its acceleration becomes zero is:

- (A) 6 m/s
 - (B) 10 m/s
 - (C) 8 m/s
 - (D) 4 m/s
-

5. The distance travelled by a particle starting from rest and moving with an acceleration $\frac{4}{3}\text{ ms}^{-2}$, in the third second is:

- (A) 6 m
 - (B) 4 m
 - (C) $\frac{10}{3}$ m
 - (D) $\frac{19}{3}$ m
-

6. A projectile is projected with velocity of 40 m/s at an angle θ with the horizontal. If R is the horizontal range covered by the projectile and after t seconds its inclination with horizontal becomes zero, then the value of $\cot \theta$ is:

[Take, $g = 10 \text{ m/s}^2$]

- (A) $\frac{R}{20t^2}$
 - (B) $\frac{R}{10t^2}$
 - (C) $\frac{5R}{t^2}$
 - (D) $\frac{R}{t^2}$
-

7. A rigid body rotates about a fixed axis with variable angular velocity $\omega = \alpha - \beta t$ at time t , where α, β are constants. The angle through which it rotates before it stops is:

- (A) $\frac{\alpha^2}{2\beta}$
 - (B) $\frac{\alpha^2 - \beta^2}{2\alpha}$
 - (C) $\frac{\alpha^2 - \beta^2}{2\beta}$
 - (D) $\frac{(\alpha - \beta)\alpha}{2}$
-

8. The range of a projectile projected at an angle of 15° with the horizontal is 50 m. If the projectile is projected with the same velocity at an angle of 45° , then its range will be:

- (A) 50 m
 - (B) $50\sqrt{2}$ m
 - (C) 100 m
 - (D) $100\sqrt{2}$ m
-

9. A particle of mass m is projected with a velocity u making an angle of 30° with the horizontal. The magnitude of angular momentum of the projectile about the point of

projection when the particle is at its maximum height h is:

- (A) $\frac{\sqrt{3}}{16} \frac{mu^3}{g}$
 - (B) $\frac{\sqrt{3}}{2} \frac{mu^2}{g}$
 - (C) $\frac{mu^3}{\sqrt{2}g}$
 - (D) zero
-

10. A body is thrown with a velocity of 9.8 m/s making an angle of 30° with the horizontal. It will hit the ground after a time:

- (A) 3.0 s
 - (B) 2.0 s
 - (C) 1.5 s
 - (D) 1.0 s
-

11. A light string passing over a smooth light pulley connects two blocks of masses m_1 and m_2 (where $m_2 > m_1$). If the acceleration of the system is $\frac{g}{\sqrt{2}}$, then the ratio of the masses $\frac{m_1}{m_2}$ is:

- (A) $\frac{\sqrt{2}-1}{\sqrt{2}+1}$
 - (B) $\frac{1+\sqrt{5}}{\sqrt{5}-1}$
 - (C) $\frac{1+\sqrt{5}}{\sqrt{2}-1}$
 - (D) $\frac{\sqrt{3}+1}{\sqrt{2}-1}$
-

12. A block of mass 1 kg is pushed up a surface inclined to horizontal at an angle of 60° by a force of 10 N parallel to the inclined surface. When the block is pushed up by 10 m along the inclined surface, the work done against frictional force is:

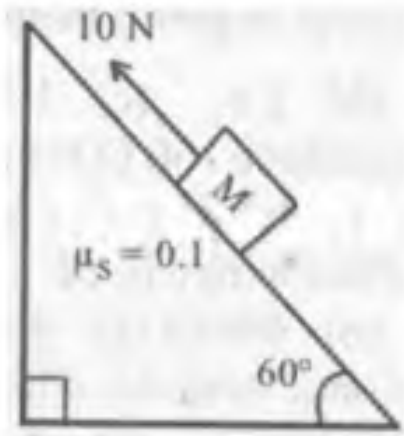

[Given: $g = 10 \text{ m/s}^2$, $\mu_s = 0.1$]

- (A) $5\sqrt{3} \text{ J}$
- (B) 5 J
- (C) $5 \times 10^3 \text{ J}$
- (D) 10 J

13. A person of mass 60 kg is inside a lift of mass 940 kg. The lift starts moving upwards with an acceleration of 1.0 m/s^2 . If $g = 10 \text{ m/s}^2$, the tension in the supporting cable is:

- (A) 8600 N
- (B) 9680 N
- (C) 11000 N
- (D) 1200 N

14. A force of $F = 0.5 \text{ N}$ is applied on the lower block as shown in the figure. The work done by the lower block on the upper block for a displacement of 3 m of the upper block with respect to the ground is (Take, $g = 10 \text{ m/s}^2$):

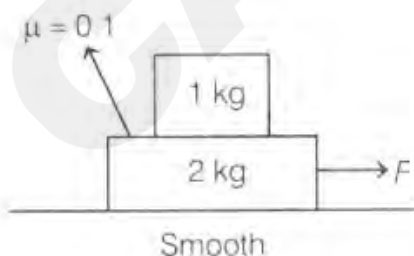

- (A) -0.5 J
- (B) 0.5 J

- (C) 2 J
(D) -2 J
-

15. A pendulum of mass 1 kg and length $l = 1$ m is released from rest at an angle $\theta = 60^\circ$. The power delivered by all the forces acting on the bob at angle $\theta = 30^\circ$ will be (Take, $g = 10 \text{ m/s}^2$):

- (A) 13.4 W
(B) 20.4 W
(C) 24.6 W
(D) zero
-

16. An ideal massless spring S can be compressed 1 m by a force of 100 N in equilibrium. The same spring is placed at the bottom of a frictionless inclined plane inclined at 30° to the horizontal. A 10 kg block M is released from rest at the top of the incline and is brought to rest momentarily after compressing the spring by 2 m. If $g = 10 \text{ m/s}^2$, what is the speed of the mass just before it touches the spring?

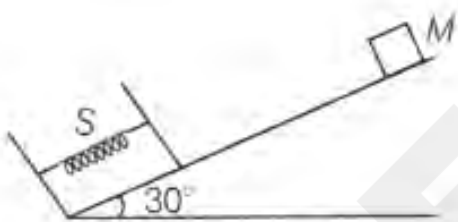

- (A) $\sqrt{20}$ m/s
(B) $\sqrt{30}$ m/s
(C) $\sqrt{10}$ m/s
(D) $\sqrt{40}$ m/s
-

17. A spherical ball of mass 20 kg is stationary at the top of a hill of height 100 m. It rolls down a smooth surface to the ground, then climbs up another hill of height 30 m and finally rolls down to a horizontal base at a height of 20 m above the ground. The velocity attained by the ball is:

- (A) 20 m/s
(B) 40 m/s

(C) $10\sqrt{30}$ m/s

(D) 10 m/s

18. A particle of mass 2 kg is on a smooth horizontal table and moves in a circular path of radius 0.6 m. The height of the table from the ground is 0.8 m. If the angular speed of the particle is 12 rad/s, the magnitude of its angular momentum about a point on the ground right under the center of the circle is:

(A) $14.4 \text{ kg m}^2\text{s}^{-1}$

(B) $8.64 \text{ kg m}^2\text{s}^{-1}$

(C) $20.16 \text{ kg m}^2\text{s}^{-1}$

(D) $11.52 \text{ kg m}^2\text{s}^{-1}$

19. A ball falling freely from a height of 4.9 m/s hits a horizontal surface. If $e = \frac{3}{4}$, then the ball will hit the surface the second time after:

(A) 1.0 s

(B) 1.5 s

(C) 2.0 s

(D) 3.0 s

20. Two bodies of mass 1 kg and 3 kg have position vectors $\hat{i} + 2\hat{j} + \hat{k}$ and $-3\hat{i} - 2\hat{j} + \hat{k}$ respectively. The magnitude of the position vector of the center of mass of this system will be similar to the magnitude of which vector?

(A) $\hat{i} - 2\hat{j} + \hat{k}$

(B) $-3\hat{i} - 2\hat{j} + \hat{k}$

(C) $-2\hat{i} + 2\hat{k}$

(D) $-2\hat{i} - \hat{j} + 2\hat{k}$

21. The moment of inertia of a cube of mass m and side a about one of its edges is equal to:

(A) $\frac{2}{3}ma^2$

(B) $\frac{4}{3}ma^2$

(C) $3ma^2$

(D) $\frac{8}{3}ma^2$

22. A body which is initially at rest at a height R above the surface of the Earth of radius R , falls freely towards the Earth. The velocity on reaching the surface of the Earth is:

(A) $\sqrt{2gR}$

(B) \sqrt{gR}

(C) $\sqrt{\frac{3}{2}gR}$

(D) $\sqrt{4gR}$

23. The distance between the Sun and Earth is R . The duration of a year if the distance between the Sun and Earth becomes $3R$ will be:

(A) $\sqrt{3}$ years

(B) 3 years

(C) 9 years

(D) $3\sqrt{3}$ years

24. For a particle inside a uniform spherical shell, the gravitational force on the particle is:

(A) Infinite

(B) Zero

(C) $\frac{-Gm_1m_2}{r^2}$

(D) $\frac{Gm_1m_2}{r^2}$

25. The kinetic energy of a satellite in its orbit around Earth is E . What should be the kinetic energy of the satellite to escape Earth's gravity?

(A) $4E$

(B) $2E$

(C) $\sqrt{2}E$

(D) E

26. Two wires of the same material (Young's modulus Y) and same length L but radii R and $2R$ respectively, are joined end to end and a weight W is suspended from the combination. The elastic potential energy in the system is:

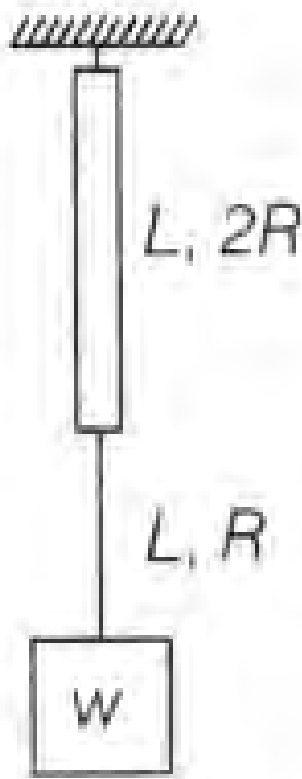

- (A) $\frac{3W^2L}{4\pi R^2Y}$
 (B) $\frac{3W^2L}{8\pi R^2Y}$
 (C) $\frac{5W^2L}{8\pi R^2Y}$
 (D) $\frac{W^2L}{\pi R^2Y}$

27. With rise in temperature, the Young's modulus of elasticity:

- (A) Changes erratically
 (B) Decreases
 (C) Increases
 (D) Remains unchanged

28. Young's modulus of materials of a wire of Length ' L ' and cross-sectional area A is Y . If the length of the wire is doubled and cross-sectional area is halved then Young's

modules will be:

- (A) $Y/4$
 - (B) $4Y$
 - (C) Y
 - (D) $2Y$
-

29. Pressure inside two soap bubbles are 1.01 and 1.02 atmosphere, respectively. The ratio of their volumes is:

- (A) 4:1
 - (B) 0.8:1
 - (C) 8:1
 - (D) 2:1
-

30. A cube of ice floats partly in water and partly in kerosene oil. The ratio of volume of ice immersed in water to that in kerosene oil (specific gravity of Kerosene oil = 0.8, specific gravity of ice = 0.9)

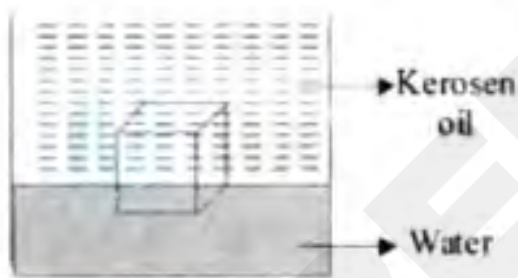

- (A) 8:9
 - (B) 5:4
 - (C) 9:10
 - (D) 1:1
-

31. A solid metallic cube having total surface area 24 m^2 is uniformly heated. If its temperature is increased by 10°C , calculate the increase in volume of the cube.

Given: $\alpha = 5.0 \times 10^{-4} \text{ C}^{-1}$

- (A) $2.4 \times 10^6 \text{ cm}^3$
- (B) $1.2 \times 10^5 \text{ cm}^3$

(C) $6.0 \times 10^4 \text{ cm}^3$

(D) $4.8 \times 10^5 \text{ cm}^3$

32. In the given cycle ABCDA, the heat required for an ideal monoatomic gas will be:

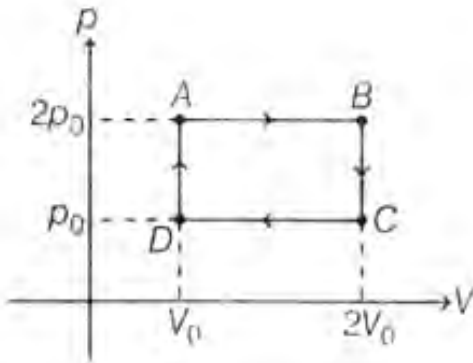

(A) p_0V_0

(B) $\frac{13}{2}p_0V_0$

(C) $\frac{11}{2}p_0V_0$

(D) $4p_0V_0$

33. A gas can be taken from A to B via two different processes ACB and ADB. When path ACB is used, $60J$ of heat flows into the system and $30J$ of work is done by the system. If path ADB is used, the work done by the system is $10J$. The heat flow into the system in path ADB is:

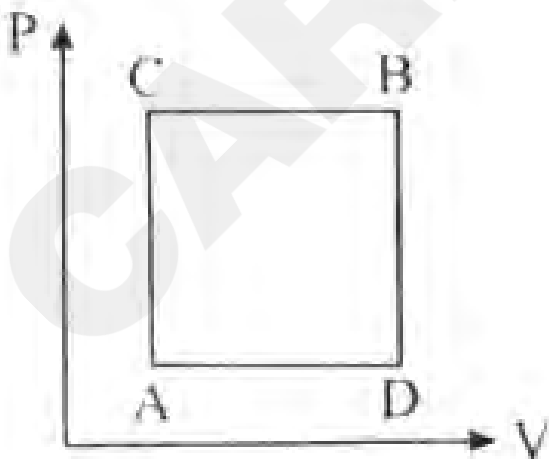

(A) $40J$

- (B) $80J$
 - (C) $100J$
 - (D) $20J$
-

34. A source supplies heat to a system at the rate of $1000W$. If the system performs work at the rate of $200W$, the rate at which internal energy of the system increases is:

- (A) $1200W$
 - (B) $600W$
 - (C) $500W$
 - (D) $800W$
-

35. On Celsius scale, the temperature of a body increases by $40^{\circ}C$. The increase in temperature on Fahrenheit scale is:

- (A) $70^{\circ}F$
 - (B) $68^{\circ}F$
 - (C) $72^{\circ}F$
 - (D) $75^{\circ}F$
-

36. In a mixture of gases, the average number of degrees of freedom per molecule is 6. The RMS speed of the molecule of the gas is c . Then the velocity of sound in the gas is:

- (A) $\frac{c}{\sqrt{3}}$
 - (B) $\frac{c}{\sqrt{2}}$
 - (C) $\frac{2c}{3}$
 - (D) $\frac{3c}{3}$
-

37. The temperature of an ideal gas is increased from 200 K to 800 K. If the RMS speed of gas at 200 K is v_0 , then the RMS speed of the gas at 800 K will be:

- (A) v_0
 - (B) $4v_0$
 - (C) $\frac{v_0}{4}$
 - (D) $2v_0$
-

38. Two vessels A and B are of the same size and are at the same temperature. A contains 1 g of hydrogen and B contains 1 g of oxygen. P_A and P_B are the pressures of the gases in A and B respectively, then $\frac{P_A}{P_B}$ is:

- (A) 8
- (B) 16
- (C) 32
- (D) 4

39. Five identical springs are used in the three configurations as shown in figure. The time periods of vertical oscillations in configurations (a), (b) and (c) are in the ratio:

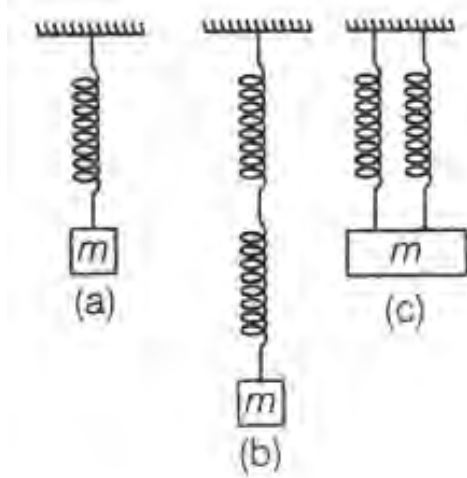

- (A) $1 : \sqrt{2} : \frac{1}{\sqrt{2}}$
- (B) $2 : \sqrt{2} : \frac{1}{\sqrt{2}}$
- (C) $\frac{1}{\sqrt{2}} : 2 : 1$
- (D) $2 : \frac{1}{\sqrt{2}} : 1$

40. A particle executes simple harmonic motion between $x = -A$ and $x = +A$. If the time taken by the particle to go from $x = 0$ to $\frac{A}{2}$ is 2 s, then the time taken by the particle in going from $x = \frac{A}{2}$ to A is:

- (A) 3 s
- (B) 2 s
- (C) 1.5 s
- (D) 4 s

41. A simple pendulum doing small oscillations at a place R height above the Earth's surface has a time period of $T_1 = 4\text{ s}$. T_2 would be its time period if it is brought to a point which is at a height $2R$ from the Earth's surface. Choose the correct relation [$R =$ radius of Earth]:

- (A) $T_1 = T_2$
 - (B) $2T_1 = 3T_2$
 - (C) $3T_1 = 2T_2$
 - (D) $2T_1 = T_2$
-

42. The speed of sound in oxygen at STP will be approximately: (Given, $R = 8.3\text{ J}(K)^{-1}, = 1.4$)

- (A) 315 m/s
 - (B) 333 m/s
 - (C) 341 m/s
 - (D) 325 m/s
-

43. A plane progressive wave is given by $y = 2 \cos 2\pi(330t - x)$ m. The frequency of the wave is:

- (A) 165 Hz
 - (B) 330 Hz
 - (C) 660 Hz
 - (D) 340 Hz
-

44. An oil drop of radius $1\ \mu\text{m}$ is held stationary under a constant electric field of $3.65 \times 10^4\ \text{N/C}$ due to some excess electrons present on it. If the density of the oil drop is $1.26\ \text{g/cm}^3$, then the number of excess electrons on the oil drop approximately is:

Take, $g = 10\ \text{m/s}^2$

- (A) 7
 - (B) 12
 - (C) 9
 - (D) 8
-

45. The potential of a large liquid drop when eight liquid drops are combined is 20 V.

Then, the potential of each single drop was:

- (A) 10 V
 - (B) 7.5 V
 - (C) 5 V
 - (D) 2.5 V
-

46. A dust particle of mass 4×10^{-12} mg is suspended in air under the influence of an electric field of 50 N/C directed vertically upwards. How many electrons were removed from the neutral dust particle? [Take, $g = 10 \text{ m/s}^2$]

- (A) 15
 - (B) 8
 - (C) 5
 - (D) 4
-

47. The electric field at point (30, 30, 0) due to a charge of $0.008 \mu\text{C}$ placed at the origin will be: (coordinates are in cm)

- (A) $8000 \text{ N/C } \hat{i} + 8000 \text{ N/C } \hat{j}$
 - (B) $4000(\hat{i} + \hat{j}) \text{ N/C}$
 - (C) $200\sqrt{2}(\hat{i} + \hat{j}) \text{ N/C}$
 - (D) $400\sqrt{2}(\hat{i} + \hat{j}) \text{ N/C}$
-

48. If two charges q_1 and q_2 are separated with distance 'd' and placed in a medium of dielectric constant K. What will be the equivalent distance between charges in air for the same electrostatic force?

- (A) $d\sqrt{K}$
 - (B) $K\sqrt{d}$
 - (C) $1.5d\sqrt{K}$
 - (D) $2d\sqrt{K}$
-

49. Electric potential at a point 'P' due to a point charge of $5 \times 10^{-9} \text{ C}$ is 50 V. The

distance of 'P' from the point charge is:

(Assume, $\frac{1}{4\pi\epsilon_0} = 9 \times 10^9 \text{ Nm}^2\text{C}^{-2}$)

- (A) 3 cm
 - (B) 9 cm
 - (C) 90 cm
 - (D) 0.9 cm
-

50. Five charges $+q$, $+5q$, $-2q$, $+3q$ and $-4q$ are situated as shown in the figure. The electric flux due to this configuration through the surface S is:



- (A) $\frac{5q}{\epsilon_0}$
 - (B) $\frac{4q}{\epsilon_0}$
 - (C) $\frac{3q}{\epsilon_0}$
 - (D) $\frac{q}{\epsilon_0}$
-

51. A parallel plate capacitor with plate area A and plate separation $d = 2$ m has a capacitance of $4\mu\text{F}$. The new capacitance of the system if half of the space between them is filled with a dielectric material of dielectric constant $K = 3$ (as shown in the figure) will be:

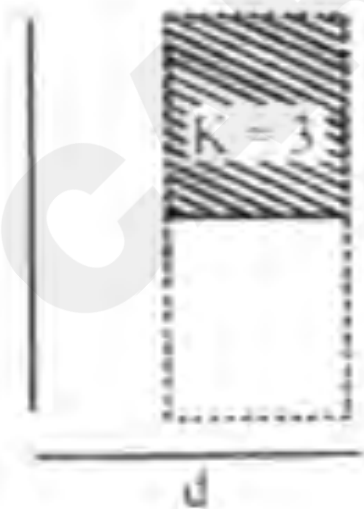

- (A) $2\mu F$
- (B) $32\mu F$
- (C) $6\mu F$
- (D) $8\mu F$

52. In the given circuit, $E_1 = E_2 = E_3 = 2V$ and $R_1 = R_2 = 4\Omega$, then the current flowing through the branch AB is:

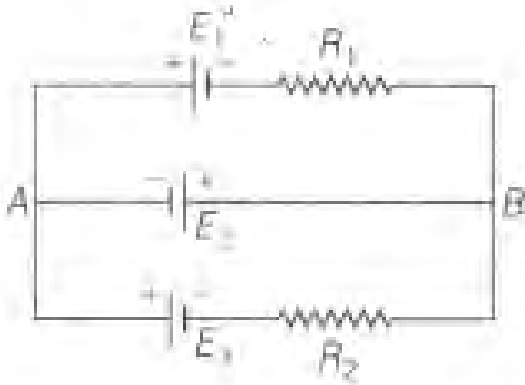

- (A) 0
- (B) 2A from A to B
- (C) 2A from B to A
- (D) 5A from B to B

53. In the following circuit diagram, when the 3Ω resistor is removed, the equivalent resistance of the network:

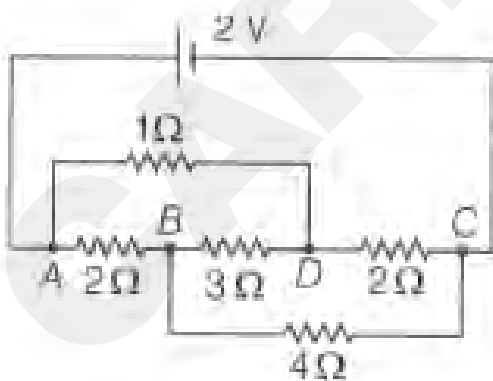

- (A) Increases
- (B) Decreases
- (C) Remains the same

(D) None of these

54. A conducting wire is stretched by applying a deforming force, so that its diameter decreases to 40% of the original value. The percentage change in its resistance will be:

- (A) 0.9%
 - (B) 0.12%
 - (C) 1.6%
 - (D) 0.5%
-

55. A wire of resistance 160Ω is melted and drawn into a wire of one-fourth of its length. The new resistance of the wire will be:

- (A) 10Ω
 - (B) 640Ω
 - (C) 40Ω
 - (D) 16Ω
-

56. Five cells each of emf E and internal resistance r send the same amount of current through an external resistance R whether the cells are connected in parallel or in series. Then the ratio $\frac{R}{r}$ is:

- (A) 2
 - (B) $\frac{1}{2}$
 - (C) $\frac{1}{5}$
 - (D) 1
-

57. The straight wire AB carries a current I . The ends of the wire subtend angles θ_1 and θ_2 at the point P as shown in the figure. The magnetic field at the point P is:

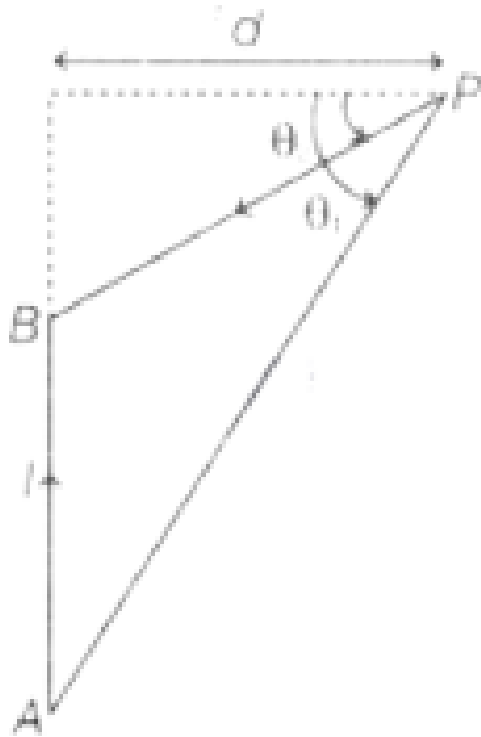

- (A) $\frac{\mu_0 I}{4\pi d}(\sin \theta_1 - \sin \theta_2)$
 (B) $\frac{\mu_0 I}{4\pi d}(\sin \theta_1 + \sin \theta_2)$
 (C) $\frac{\mu_0 I}{4\pi d}(\cos \theta_1 - \cos \theta_2)$
 (D) $\frac{\mu_0 I}{4\pi d}(\cos \theta_1 + \cos \theta_2)$

58. A long straight wire of radius a carries a steady current I . The current is uniformly distributed across its cross-section. The ratio of the magnetic field at $a/2$ and $2a$ from the axis of the wire is:

- (A) 1 : 4
 (B) 4 : 1
 (C) 1 : 1
 (D) 3 : 4

59. The electrostatic force F_1 and magnetic force F_2 acting on a charge q moving with velocity v can be written as:

- (A) $\vec{F}_1 = q\vec{v} \cdot \vec{E}, \vec{F}_2 = q(\vec{B} \cdot \vec{v})$
 (B) $\vec{F}_1 = q\vec{E}, \vec{F}_2 = q(\vec{B} \times \vec{v})$

(C) $\vec{F}_1 = q\vec{E}, \vec{F}_2 = q(\vec{v} \times \vec{B})$

(D) $\vec{F}_1 = q\vec{E}, \vec{F}_2 = q(\vec{B} \times \vec{v})$

60. Inside a solenoid of radius 0.5 m, the magnetic field is changing at a rate of 50×10^{-6} T/s. The acceleration of an electron placed at a distance of 0.3 m from the axis of the solenoid will be:

(A) $23 \times 10^6 \text{ m/s}^2$

(B) $26 \times 10^6 \text{ m/s}^2$

(C) $1.3 \times 10^9 \text{ m/s}^2$

(D) $26 \times 10^9 \text{ m/s}^2$

61. There are two long co-axial solenoids of the same length l . The inner and outer coils have radii r_1 and r_2 and the number of turns per unit length n_1 and n_2 , respectively. The ratio of mutual inductance to the self-inductance of the inner coil is:

(A) $\frac{n_1}{n_2}$

(B) $\frac{n_2}{n_1} \cdot \frac{r_1}{r_2}$

(C) $\frac{n_2}{n_1} \cdot \frac{r_2^2}{r_1^2}$

(D) $\frac{n_2}{n_1}$

62. A rectangular loop of length 2.5 m and width 2 m is placed at 60° to a magnetic field of 4 T. The loop is removed from the field in 10 sec. The average emf induced in the loop during this time is:

(A) -2 V

(B) $+2 \text{ V}$

(C) $+1 \text{ V}$

(D) -1 V

63. Find the average value of the current shown graphically from $t = 0$ to $t = 2 \text{ s}$.

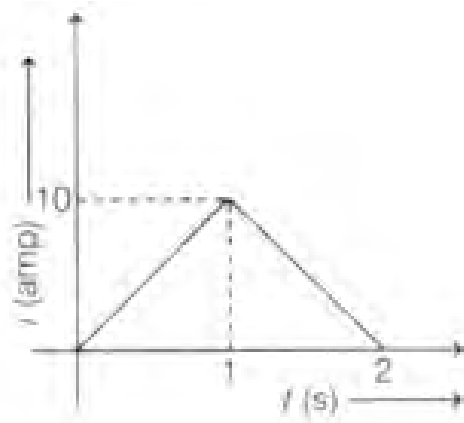

- (A) 3 A
- (B) 5 A
- (C) 10 A
- (D) 4 A

64. In an AC circuit, an inductor, a capacitor, and a resistor are connected in series with $X_L = R = X_C$. The impedance of this circuit is:

- (A) $2R^2$
- (B) Zero
- (C) R
- (D) $R\sqrt{2}$

65. An alternating voltage $V(t) = 220 \sin 100\pi t$ volt is applied to a purely resistive load of 50Ω . The time taken for the current to rise from half of the peak value to the peak value is:

- (A) 5 ms
- (B) 3.3 ms
- (C) 7.2 ms
- (D) 2.2 ms

66. A parallel plate capacitor consists of two circular plates of radius $R = 0.1$ m. They are separated by a short distance. If the electric field between the capacitor plates changes as:

$$\frac{dE}{dt} = 6 \times 10^{13} \frac{V}{m \cdot s}$$

then the value of the displacement current is:

- (A) 15.25 A
 - (B) 6.25 A
 - (C) 16.67 A
 - (D) 4.69 A
-

67. Electromagnetic waves travel in a medium with speed 1.5×10^8 m/s. The relative permeability of the medium is 2.0. The relative permittivity will be:

- (A) 5
 - (B) 1
 - (C) 4
 - (D) 2
-

68. Power of a biconvex lens is P diopter. When it is cut into two symmetrical halves by a plane containing the principal axis, the ratio of the power of two halves is:

- (A) 1:2
 - (B) 2:1
 - (C) 1:4
 - (D) 1:1
-

69. The magnifying power of a telescope is 9. When adjusted for parallel rays, the distance between the objective and eyepiece is 20 cm. The ratio of the focal length of the objective lens to the focal length of the eyepiece is:

- (A) 8
 - (B) 7
 - (C) 9
 - (D) 12
-

70. In normal adjustment, for a refracting telescope, the distance between the objective

and eyepiece is 30 cm. The focal length of the objective, when the angular magnification of the telescope is 2, will be:

- (A) 20 cm
 - (B) 30 cm
 - (C) 10 cm
 - (D) 15 cm
-

71. If the distance between an object and its two times magnified virtual image produced by a curved mirror is 15 cm, the focal length of the mirror must be:

- (A) $\frac{10}{3}$ cm
 - (B) -12 cm
 - (C) -10 cm
 - (D) 15 cm
-

72. Young's double slit experiment is performed in a medium of refractive index 1.33. The maximum intensity is I_0 . The intensity at a point on the screen where the path difference between the light coming out from slits is $\lambda/4$, is:

- (A) 0
 - (B) $\frac{I_0}{2}$
 - (C) $\frac{3I_0}{8}$
 - (D) $\frac{2I_0}{3}$
-

73. In YDSE, monochromatic light falls on a screen 1.80 m from two slits separated by 2.08 mm. The first and second order bright fringes are separated by 0.553 mm. The wavelength of light used is:

- (A) 520 nm
 - (B) 639 nm
 - (C) 715 nm
 - (D) None of these
-

74. A microwave of wavelength 2.0 cm falls normally on a slit of width 4.0 cm. The

angular spread of the central maxima of the diffraction pattern obtained on a screen 1.5 m away from the slit will be:

- (A) 60°
 - (B) 45°
 - (C) 15°
 - (D) 30°
-

75. The property of light which cannot be explained by Huygen's construction of a wavefront is:

- (A) Refraction
 - (B) Reflection
 - (C) Diffraction
 - (D) Origin of spectra
-

76. When a light ray incidents on the surface of a medium, the reflected ray is completely polarized. Then the angle between reflected and refracted rays is:

- (A) 45°
 - (B) 90°
 - (C) 120°
 - (D) 180°
-

77. Which figure shows the correct variation of applied potential difference (V) with photoelectric current (I) at two different intensities of light ($I_1 < I_2$) of same wavelengths:

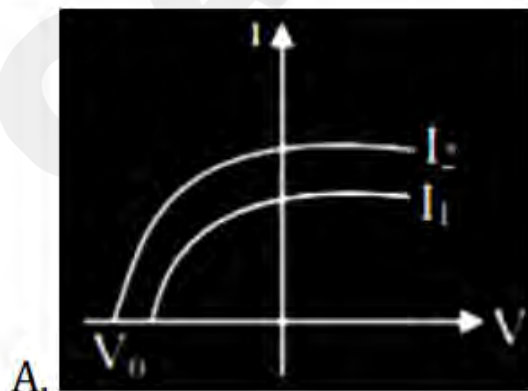

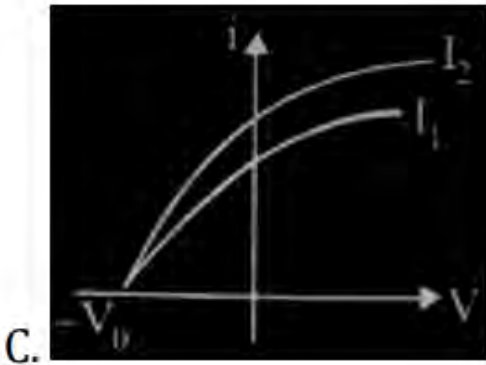
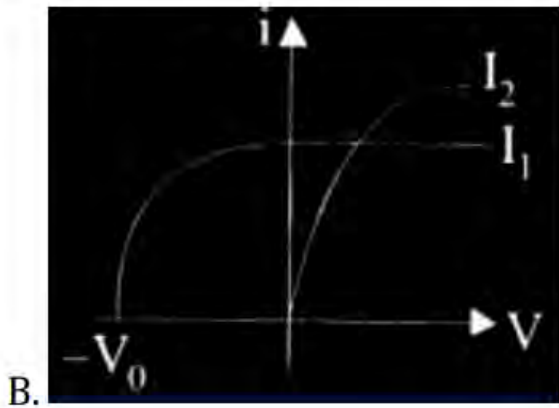

78. The acceptor level of a p-type semiconductor is 6 eV. The maximum wavelength of light which can create a hole would be: Given $hc = 1242 \text{ eV nm}$.

- (A) 407 nm
- (B) 414 nm
- (C) 207 nm
- (D) 103.5 nm

79. When light is incident on a metal surface, the maximum kinetic energy of emitted

electrons:

- (A) Varies with intensity of light
 - (B) Varies with frequency of light
 - (C) Varies with speed of light
 - (D) Varies irregularly
-

80. If the kinetic energy of a free electron doubles, its de-Broglie wavelength changes by the factor:

- (A) 2
 - (B) $\frac{1}{2}$
 - (C) $\sqrt{2}$
 - (D) $\frac{1}{\sqrt{2}}$
-

81. Which of the following transitions of He^+ ion will give rise to a spectral line that has the same wavelength as the spectral line in a hydrogen atom?

- (A) $n = 4 \rightarrow n = 2$
 - (B) $n = 6 \rightarrow n = 5$
 - (C) $n = 6 \rightarrow n = 3$
 - (D) None of these
-

82. The ratio of the shortest wavelength of the Balmer series to the shortest wavelength of the Lyman series for the hydrogen atom is:

- (A) 4:1
 - (B) 1:2
 - (C) 1:4
 - (D) 2:1
-

83. The minimum excitation energy of an electron revolving in the first orbit of hydrogen is:

- (A) 3.4 eV
- (B) 8.5 eV

- (C) 10.2 eV
 (D) 13.6 eV

84. The atomic mass of ${}^6\text{C}^{12}$ is 12.000000 u and that of ${}^6\text{C}^{13}$ is 13.003354 u. The required energy to remove a neutron from ${}^6\text{C}^{13}$, if the mass of the neutron is 1.008665 u, will be:

- (A) 62.5 MeV
 (B) 6.25 MeV
 (C) 4.95 MeV
 (D) 49.5 MeV

85. The nucleus having highest binding energy per nucleon is:

- (A) ${}^{16}_8\text{O}$
 (B) ${}^{56}_{26}\text{Fe}$
 (C) ${}^{208}_{84}\text{Pb}$
 (D) ${}^4_2\text{He}$

86. Identify the correct output signal Y in the given combination of gates for the given inputs A and B shown in the figure.

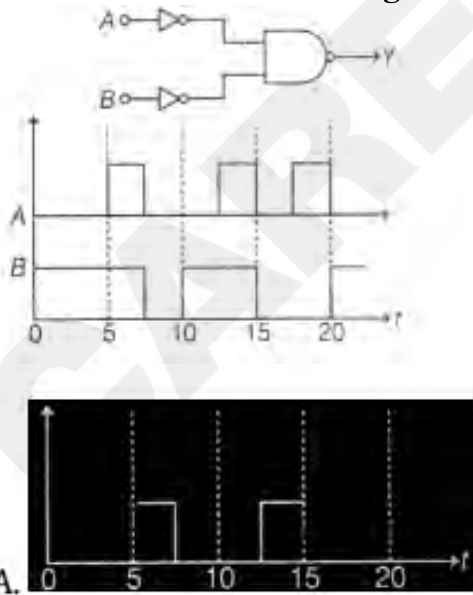

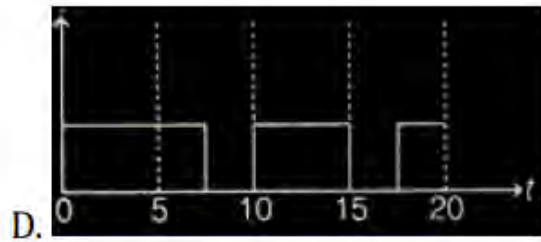
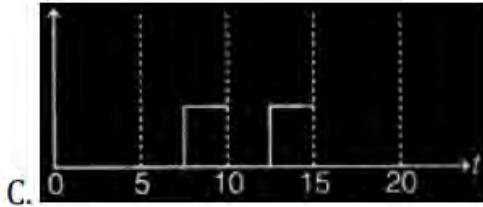
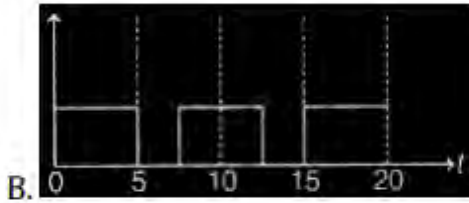

87. Identify the logic gate given in the circuit:

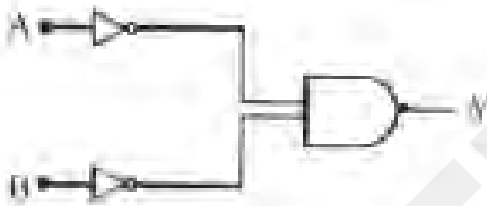

- (A) NAND gate
- (B) OR gate
- (C) AND gate
- (D) NOR gate

88. A reverse biased zener diode when operated in the breakdown region works as:

- (A) an amplifier
 - (B) an oscillator
 - (C) a voltage regulator
 - (D) a rectifier
-

89. Identify the logic operation performed by the following circuit.

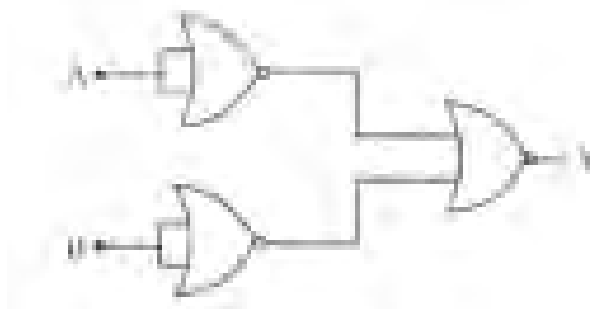

- (A) OR
 - (B) AND
 - (C) NOT
 - (D) NAND
-

90. One main scale division of a vernier caliper is equal to m units. If the m^{th} division of main scale coincides with the $(n + 1)^{\text{th}}$ division of vernier scale, the least count of the vernier caliper is:

- (A) $\frac{n}{(n+1)}$
 - (B) $\frac{m}{(n+1)}$
 - (C) $\frac{1}{(n+1)}$
 - (D) $\frac{m}{n(n+1)}$
-

Chemistry

1. A 1 L closed flask contains a mixture of 4 g of methane and 4.4 g of carbon dioxide. The pressure inside the flask at 27°C is (Assume ideal behaviour of gases):

- (A) 8.6 atm
 - (B) 2.2 atm
 - (C) 4.2 atm
 - (D) 6.1 atm
-

2. In which mode of expression, the concentration of a solution remains independent of temperature?

- (A) Molarity

- (B) Normality
 - (C) Formality
 - (D) Molality
-

3. The degeneracy of hydrogen atom that has energy equal to $-\frac{R_H}{9}$ is (where $R_H =$ Rydberg constant)

- (A) 6
 - (B) 8
 - (C) 5
 - (D) 9
-

4. If the de-Broglie wavelength of a particle of mass (m) is 100 times its velocity, then its value in terms of its mass (m) and Planck constant (h) is:

- (A) $\frac{1}{10} \sqrt{\frac{m}{h}}$
 - (B) $10 \sqrt{\frac{h}{m}}$
 - (C) $\frac{1}{10} \sqrt{\frac{h}{m}}$
 - (D) $10 \sqrt{\frac{m}{h}}$
-

5. The energy of the second orbit of a hydrogen atom is -5.45×10^{-19} J. What is the energy of the first orbit of Li^{2+} ion (in J)?

- (A) -1.962×10^{-18}
 - (B) -1.962×10^{-17}
 - (C) -3.924×10^{-17}
 - (D) -3.924×10^{-18}
-

6. A photon of wavelength 3000 \AA strikes a metal surface. The work function of the metal is 2.13 eV. What is the kinetic energy of the emitted photoelectron?

($h = 6.626 \times 10^{-34} \text{ Js}$)

- (A) 4.0 eV
- (B) 3.0 eV
- (C) 2.0 eV

(D) 1.0 eV

7. A stream of electrons from a heated filament was passed between two charged plates at a potential difference V volt. If e and m are the charge and mass of an electron, then the value of $\frac{h}{\lambda}$ is:

(A) \sqrt{meV}

(B) $\sqrt{2meV}$

(C) meV

(D) $2meV$

8. Electron affinity is positive when:

(A) O changes into O^-

(B) O^- changes to O^{2-}

(C) O changes into O^+

(D) O changes to O^{2+}

9. The ionic radii in (\AA) of N^{3-} , O^{2-} and F^- are respectively.

(A) 1.71, 1.40 and 1.36

(B) 1.71, 1.36 and 1.40

(C) 1.36, 1.40 and 1.71

(D) 1.36, 1.71 and 1.40

10. Intramolecular hydrogen bonding is found in

(A) o-nitrophenol

(B) m-nitrophenol

(C) p-nitrophenol

(D) phenol

11. The hybridisation scheme for the central atom includes a d-orbital contribution in

(A) I_3^-

(B) PCl_3

(C) NO_3^-

(D) H_2Se

12. In the following species, how many species have the same magnetic moment?

(i) Cr^{2+} (ii) Mn^{3+} (iii) Ni^{2+} (iv) Sc^{2+} (v) Zn^{2+} (vi) V^{3+} (vii) Ti^{4+}

(A) 1

(B) 3

(C) 2

(D) 4

13. The spin only magnetic moment of Fe^{3+} ion (in BM) is approximately.

(A) 4

(B) 5

(C) 6

(D) 7

14. Which one of the following compounds is having maximum 'lone pair-lone pair' electron repulsions?

(A) ClF_3

(B) IF_5

(C) SF_4

(D) XeF_2

15. Identify the species having one π -bond and maximum number of canonical forms from the following:

(A) SO_3

(B) O_2

(C) SO_2

(D) CO_3^{2-}

16. $\text{sp}^3 \text{d}^2$ hybridisation is not displayed by:

(A) BrF_5

(B) SF_6

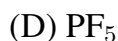

17. What would be the amount of heat absorbed in the cyclic process shown below?

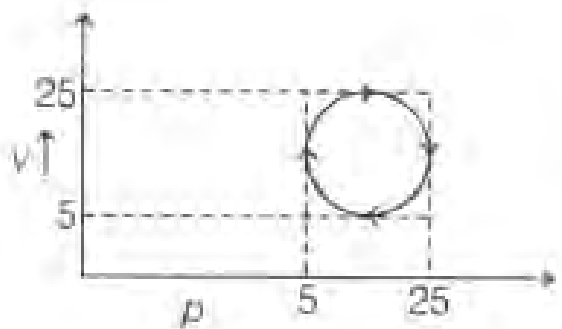

(A) 5π J

(B) 15π J

(C) 25π J

(D) 100π J

18. The bond dissociation energy of X_2 , Y_2 and XY are in the ratio of 1 : 0.5 : 1. ΔH for the formation of XY is -200 kJ/mol. The bond dissociation energy of X_2 will be

(A) 200 kJ/mol

(B) 100 kJ/mol

(C) 400 kJ/mol

(D) 800 kJ/mol

19. Which of the following relation is not correct?

(A) $\Delta H = \Delta U - P\Delta V$

(B) $\Delta U = q + W$

(C) $\Delta S_{\text{sys}} + \Delta S_{\text{surr}} \geq 0$

(D) $\Delta G = \Delta H - T\Delta S$

20. The standard Gibbs energy (ΔG°) for the following reaction is

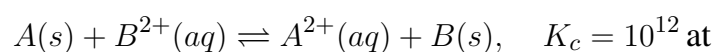

(K_c = equilibrium constant)

- (A) -150 kJ/mol
 - (B) -96.80 kJ/mol
 - (C) -68.47 kJ/mol
 - (D) -100 kJ/mol
-

21. The combustion of benzene (L) gives CO₂ (g) and H₂O (L). Given that heat of combustion of benzene at constant volume is -3263.9 kJ/mol at 25°C, heat of combustion (in kJ/mol) of benzene at constant pressure will be: (R = 8.314 JK⁻¹ mol⁻¹)

- (A) 4152.6
 - (B) 452.46
 - (C) 3260
 - (D) -3267.6
-

22. Choose the correct option for free expansion of an ideal gas under adiabatic condition from the following:

- (A) $q = 0, \Delta T \neq 0, w = 0$
 - (B) $q = 0, \Delta T < 0, w \neq 0$
 - (C) $q \neq 0, \Delta T = 0, w = 0$
 - (D) $q = 0, \Delta T = 0, w = 0$
-

23. Le-Chatelier's principle is not applicable to

- (A) $\text{H}_2(g) + \text{I}_2(g) \rightleftharpoons 2\text{HI}(g)$
 - (B) $\text{Fe}(s) + \text{S}(s) \rightleftharpoons \text{FeS}(s)$
 - (C) $\text{N}_2(g) + 3\text{H}_2(g) \rightleftharpoons 2\text{NH}_3(g)$
 - (D) $\text{N}_2(g) + \text{O}_2(g) \rightleftharpoons 2\text{NO}(g)$
-

24. The ratio $\frac{K_p}{K_c}$ for the reaction

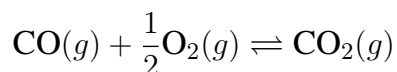

is:

- (A) $(RT)^{1/2}$
- (B) RT

(C) 1

(D) $\frac{1}{\sqrt{RT}}$

25. The pH of 1 N aqueous solutions of HCl, CH₃COOH and HCOOH follows the order:

(A) HCl > HCOOH > CH₃COOH

(B) HCl = HCOOH > CH₃COOH

(C) CH₃COOH > HCOOH > HCl

(D) CH₃COOH = HCOOH > HCl

26. 20 mL of 0.1 M acetic acid is mixed with 50 mL of potassium acetate. K_a of acetic acid = 1.8×10^{-5} at 27°C. Calculate the concentration of potassium acetate if the pH of the mixture is 4.8.

(A) 0.1 M

(B) 0.04 M

(C) 0.03 M

(D) 0.02 M

27. What is the stoichiometric coefficient of SO₂ in the following balanced reaction?

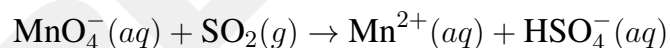

(in acidic solution)

(A) 5

(B) 4

(C) 3

(D) 2

28. Volume of M/8 KMnO₄ solution required to react completely with 25.0 cm³ of M/4 FeSO₄ in acidic medium is:

(A) 8.0 mL

(B) 5.0 mL

(C) 15.0 mL

(D) 10.0 mL

29. Which of the following is only a redox reaction but not a disproportionation reaction?

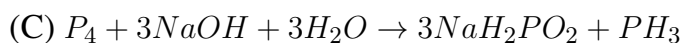
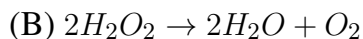
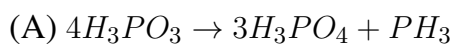

30. Among the following, the correct statements are:

I. LiH, BeH₂ and MgH₂ are saline hydrides with significant covalent character

II. Saline hydrides are volatile

III. Electron - precise hydrides are Lewis bases

IV. The formula for chromium hydride is CrH

(A) I, III only

(B) II, IV only

(C) I, IV only

(D) III, IV only

31. In which of the following reactions of H₂O₂ acts as an oxidizing agent (either in acidic, alkaline, or neutral medium)?

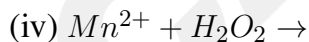
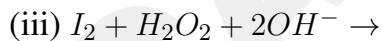
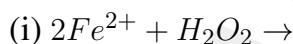

(A) (ii), (iii)

(B) (i), (iv)

(C) (i), (iii)

(D) (ii), (iv)

32. The strongest reducing agent among the following is:

- (A) SbH_3
 - (B) NH_3
 - (C) BiH_3
 - (D) PH_3
-

33. The correct order of melting points of the following salts is:

- LiCl (I)
- LiF (II)
- LiBr (III)

- (A) $I > II > III$
 - (B) $II > I > III$
 - (C) $III > II > I$
 - (D) $II > III > I$
-

34. Which among the following is used in detergent?

- (A) Sodium acetate
 - (B) Sodium stearate
 - (C) Calcium stearate
 - (D) Sodium lauryl sulphate
-

35. Thermal decomposition of lithium nitrate gives:

- (A) $\text{LiO}_2, \text{O}_2, \text{NO}_2$
 - (B) $\text{Li}_2\text{O}, \text{O}_2, \text{N}_2\text{O}$
 - (C) $\text{Li}_2\text{O}, \text{O}_2, \text{N}_2$
 - (D) $\text{Li}_2\text{O}, \text{O}_2, \text{NO}_2$
-

36. The number of geometrical isomers possible for the compound, $\text{CH}_3\text{CH} = \text{CH} - \text{CH} = \text{CH}_2$ is:

- (A) 2
- (B) 3
- (C) 4

(D) 6

37. Correct order of stability of carbanion is:

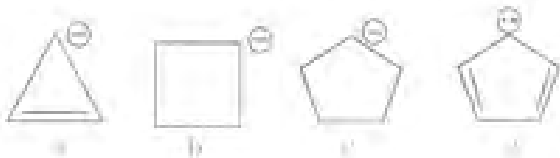

- (A) $C > B > D > A$
(B) $A > B > C > D$
(C) $D > A > C > B$
(D) $D > C > B > A$
-

38. Which of the following is not correct about Grignard reagent?

- (A) It is a nucleophile
(B) Forms new carbon-carbon bond
(C) Reacts with carbonyl compounds
(D) It is an organomanganese compound
-

39. The IUPAC name of the following molecule is:

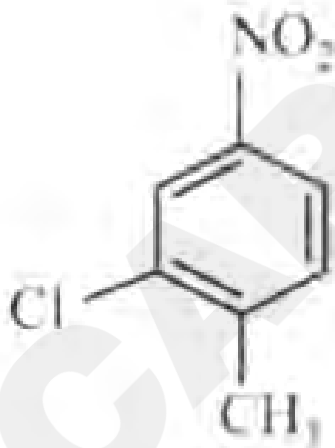

- (A) 2-Methyl-5-nitro-1-chlorobenzene
(B) 3-Chloro-4-methyl-1-nitrobenzene
(C) 2-Chloro-1-methyl-4-nitrobenzene
(D) 2-Chloro-4-nitro-1-methylbenzene

40. Choose the correct stability order of the given free radicals.

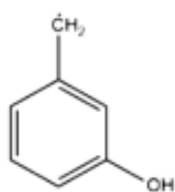

I

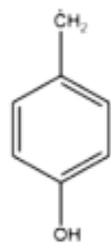

II

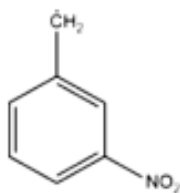

III

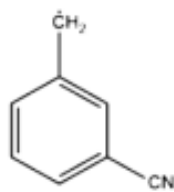

IV

- (A) $I > II > III > IV$
(B) $II > I > IV > III$
(C) $II = I > IV > III$
(D) $III > IV > II > I$
-

41. Which of the following is the strongest Bronsted base?



A.

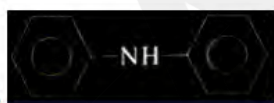

B.



42. The major product X in the following given reaction is:

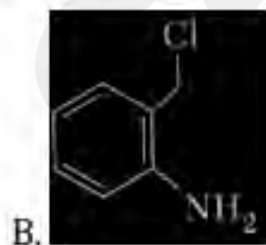
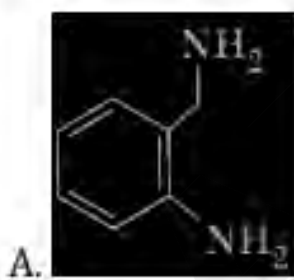
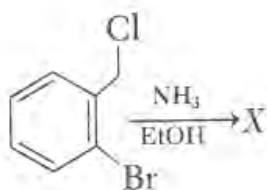

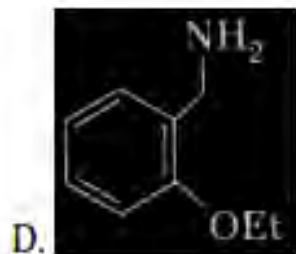
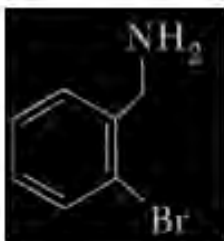

43. The major product of the reaction between $\text{CH}_3\text{CH}_2\text{ONa}$ and $(\text{CH}_3)_3\text{CCl}$ in ethanol is:

- (A) $\text{CH}_3\text{CH}_2\text{OC}(\text{CH}_3)_3$
- (B) $\text{CH}_2 = \text{C}(\text{CH}_3)_2$
- (C) $\text{CH}_3\text{CH}_2\text{C}(\text{CH}_3)_3$
- (D) $\text{CH}_3\text{CH} = \text{CHCH}_3$

44. Dinitrogen is a robust compound, but reacts at high altitude to form oxides. The oxide of nitrogen that can damage plant leaves and retard photosynthesis is:

- (A) NO
- (B) NO_3^-
- (C) NO_2
- (D) NO_2^-

45. A decimolar solution potassium ferrocyanide is 50% dissociated at 300 K. The osmotic pressure of solution is ($R = 8.314 \text{ J K}^{-1} \text{ mol}^{-1}$):

- (A) 7.48 atm
- (B) 4.99 atm
- (C) 3.74 atm
- (D) 6.23 atm

46. 58.5 g of NaCl and 180 g of glucose were separately dissolved in 1000 mL of water. Identify the correct statement regarding the elevation of boiling point of the resulting solution.

- (A) NaCl solution will show higher elevation of boiling point.
 - (B) Glucose solution will show higher elevation of boiling point.
 - (C) Both solutions will show equal elevation of boiling point.
 - (D) None will show boiling point elevation.
-

47. One molar concentration of a solution represents:

- (A) 1 mole of solute in 1 kg of solution.
 - (B) 1 mole of solute in 1 L of solution.
 - (C) 1 mole of solvent in 1 kg of solution.
 - (D) 1 mole of solvent in 1 L of solution.
-

48. Which of the following substances show the highest colligative properties?

- (A) 0.1M BaCl₂
 - (B) 0.1M AgNO₃
 - (C) 0.1M urea
 - (D) 0.1M (NH₄)₃PO₄
-

49. The pH of 0.5 L of 1.0 M NaCl solution after electrolysis for 965 s using 5.0 A current is:

- (A) 1.0
 - (B) 12.7
 - (C) 1.30
 - (D) 13.0
-

50. Calculate the molarity of a solution containing 5 g of NaOH dissolved in the product of H₂ – O₂ fuel cell operated at 1 A current for 595.1 hours. (Assume F = 96500C/mol of electron and molecular weight of NaOH as 40 g/mol).

- (A) 0.625 M
- (B) 0.05 M

- (C) 0.1 M
(D) 6.25 M
-

51. When the same quantity of electricity is passed through the aqueous solutions of the given electrolytes for the same amount of time, which metal will be deposited in maximum amount on the cathode?

- (A) ZnSO_4
(B) FeCl_3
(C) AgNO_3
(D) NiCl_2
-

52. For the reaction $2\text{SO}_2 + \text{O}_2 \rightleftharpoons 2\text{SO}_3$, the rate of disappearance of O_2 is $2 \times 10^{-4} \text{ mol L}^{-1} \text{ s}^{-1}$. The rate of appearance of SO_3 is:

- (A) $2 \times 10^{-4} \text{ mol L}^{-1} \text{ s}^{-1}$
(B) $4 \times 10^{-4} \text{ mol L}^{-1} \text{ s}^{-1}$
(C) $1 \times 10^{-1} \text{ mol L}^{-1} \text{ s}^{-1}$
(D) $6 \times 10^{-4} \text{ mol L}^{-1} \text{ s}^{-1}$
-

53. If for a first-order reaction, the value of A and E_a are $4 \times 10^{13} \text{ s}^{-1}$ and 98.6 kJ mol^{-1} respectively, then at what temperature will its half-life be 10 minutes?

- (A) 330 K
(B) 300 K
(C) 330.95 K
(D) 311.15 K
-

54. In the chemical reaction $\text{A} \rightarrow \text{B}$, what is the order of the reaction? Given that, the rate of reaction doubles if the concentration of A is increased four times.

- (A) 2
(B) 1.5
(C) 0.5
(D) 1
-

55. Calculate the activation energy of a reaction, whose rate constant doubles on raising the temperature from 300 K to 600 K.

- (A) 3.45 kJ/mol
 - (B) 6.90 kJ/mol
 - (C) 9.68 kJ/mol
 - (D) 19.6 kJ/mol
-

56. In the reaction, $A \rightarrow$ products, if the concentration of the reactant is doubled but the rate of reaction remains unchanged, what is the order of the reaction with respect to A?

- (A) 1
 - (B) 2
 - (C) 0.5
 - (D) 0
-

57. In a first-order reaction, the concentration of the reactant decreases from 0.8 M to 0.4 M in 15 minutes. The time taken for the concentration to change from 0.1 M to 0.025 M is:

- (A) 7.5 minutes
 - (B) 15 minutes
 - (C) 30 minutes
 - (D) 60 minutes
-

58. The charge on colloidal particles is due to:

- (A) Presence of electrolyte
 - (B) Very small size of particles
 - (C) Adsorption of ions from the solution
 - (D) Can't be determined
-

59. The chemical composition of 'slag' formed during the smelting process in the extraction of copper is:

- (A) $\text{Cu}_2\text{O} + \text{FeS}$
- (B) FeSiO_3

- (C) CuFeS_2
(D) $\text{Cu}_2\text{S} + \text{FeO}$
-

60. Calamine, malachite, magnetite, and cryolite, respectively, are:

- (A) ZnCO_3 , $\text{CuCO}_3 \cdot \text{Cu(OH)}_2$, Fe_3O_4 , Na_3AlF_6
(B) ZnSO_4 , Cu(OH)_2 , Fe_3O_4 , Na_3AlF_6
(C) ZnSO_4 , CuCO_3 , Fe_2O_3 , AlF_3
(D) ZnCO_3 , CuCO_3 , Fe_2O_3 , Na_3AlF_6
-

61. In which of the following molecules, all bond lengths are not equal?

- (A) SF_6
(B) PCl_5
(C) BCl_3
(D) CCl_4
-

62. The sol formed in the following unbalanced equation is:



- (A) As_2S_2
(B) As_2S_3
(C) As
(D) S
-

63. Which of the following has least tendency to liberate H_2 from mineral acids?

- (A) Cu
(B) Mn
(C) Ni
(D) Zn
-

64. The metal that shows highest and maximum number of oxidation states is:

- (A) Fe
(B) Mn

- (C) Ti
(D) Co
-

65. Hybridisation and geometry of $[\text{Ni}(\text{CN})_4]^{2-}$ are:

- (A) sp^3 and tetrahedral
(B) sp^3 and square planar
(C) sp^3 and tetrahedral
(D) dsp^2 and square planar
-

66. Match List I with List II.

List I (Complex)	List II (Oxidation Number of Metal)
A. $\text{Ni}(\text{CO})_4$	I. +1
B. $[\text{Fe}(\text{H}_2\text{O})_5\text{NO}]^{2+}$	II. Zero
C. $[\text{Co}(\text{CO})_5]^{2-}$	III. -1
D. $[\text{Cr}_2(\text{CO})_{10}]^{2-}$	IV. -2

- (A) A-II, B-I, C-IV, D-III
(B) A-II, B-IV, C-I, D-III
(C) A-II, B-III, C-I, D-IV
(D) A-I, B-II, C-IV, D-III
-

67. Which of the following is the correct order of ligand field strength?

- (A) $\text{CO} < \text{NH}_3 < \text{en} < \text{C}_2\text{O}_4^{2-} < \text{S}^{2-}$
(B) $\text{S}^{2-} < \text{C}_2\text{O}_4^{2-} < \text{NH}_3 < \text{en} < \text{CO}$
(C) $\text{NH}_3 < \text{en} < \text{CO} < \text{S}^{2-} < \text{C}_2\text{O}_4^{2-}$
(D) $\text{S}^{2-} < \text{NH}_3 < \text{en} < \text{CO} < \text{C}_2\text{O}_4^{2-}$
-

68. The correct statement among the following is:

- (A) Ferrocene has two cyclohexadiene rings coordinated to iron atom.
(B) Ferrocene has two cyclopentadienyl anion rings bonded to iron (II) ion.
(C) Perxenate ion is $[\text{XeO}_2\text{F}_2]^{2-}$.
(D) Perxenate ion is tetrahedral in shape.
-

69. The type of isomerism present in nitropentammine chromium (III) chloride is:

- (A) Optical
 - (B) Linkage
 - (C) Ionization
 - (D) Polymerization
-

70. Identify, from the following, the diamagnetic, tetrahedral complex:

- (A) $[\text{Ni}(\text{Cl})_4]^{2-}$
 - (B) $[\text{Co}(\text{C}_2\text{O}_4)_3]^{3-}$
 - (C) $[\text{Ni}(\text{CN})_4]^{2-}$
 - (D) $[\text{Ni}(\text{CO})_4]$
-

71. Ferrocene is:

- (A) $\text{Fe}(\eta^5 - \text{C}_5\text{H}_5)_2$
 - (B) $\text{Fe}(\eta^2 - \text{C}_5\text{H}_5)_2$
 - (C) $\text{Cr}(\eta^5 - \text{C}_5\text{H}_5)_5$
 - (D) $\text{Os}(\eta^5 - \text{C}_5\text{H}_5)_2$
-

72. The chemical name of calgon is:

- (A) Sodium hexametaphosphate
 - (B) Potassium hexametaphosphate
 - (C) Calcium hexametaphosphate
 - (D) Sodium hexametaphosphate
-

73. The complex with the highest magnitude of crystal field splitting energy (Δ_0) is:

- (A) $[\text{Cr}(\text{OH}_2)_6]^{3+}$
 - (B) $[\text{Ti}(\text{OH}_2)_6]^{3+}$
 - (C) $[\text{Fe}(\text{OH}_2)_6]^{3+}$
 - (D) $[\text{Mn}(\text{OH}_2)_6]^{3+}$
-

74. IUPAC name of $[\text{Pt}(\text{NH}_3)_2\text{Cl}(\text{NH}_2\text{CH}_3)]\text{Cl}$ is:

- (A) (Amino methane) chloro (diammine) platinum (II) chloride.

- (B) Chlorodiammine (methanamine) platinum (II) chloride.
 (C) Diamminechloro (methanamine) platinum (II) chloride.
 (D) Diamminechloro (methylamine) platinum (IV) chloride.

75. Which of the following complexes will exhibit maximum attraction to an applied magnetic field?

- (A) $[Zn(H_2O)_6]^{2+}$
 (B) $[Co(H_2O)_6]^{2+}$
 (C) $[Co(en)_3]^{3+}$
 (D) $[Ni(H_2O)_6]^{2+}$

76. In an S_N2 substitution reaction of the type:



Which one of the following has the highest relative rate?

- (A) $CH_3 - CH - CH_2Br$ (with a CH_3 group attached to the second carbon)
 (B) $CH_3 - CH(CBr) - CH_3$ (with two CH_3 groups attached to the second carbon)
 (C) CH_3CH_2Br
 (D) $CH_3CH_2CH_2Br$

77. The final product in the following reaction Y is:

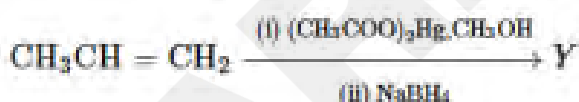

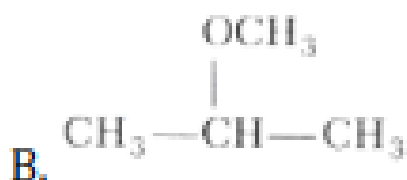

78. In the Victor-Meyer test, the color given by 1°, 2°, and 3° alcohols are respectively:

- (A) Red, colorless, blue
 (B) Red, blue, colorless
 (C) Colorless, red, blue
 (D) Red, blue, violet

79. What is X in the following reaction?

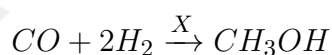

- (A) 623 K / 300 atm
 (B) KMnO_4/H
 (C) Zn /
 (D) ZnO - Cr_2O_3 , 200 – 300 atm, 573 – 673 K

80. An unknown alcohol is treated with "Lucas reagent" to determine whether the alcohol is primary, secondary, or tertiary. Which alcohol reacts fastest and by what mechanism?

- (A) Secondary alcohol by $\text{S}_{\text{N}}1$

- (B) Tertiary alcohol by S_N1
 - (C) Secondary alcohol by S_N2
 - (D) Tertiary alcohol by S_N2
-

81. Which of the following compounds will undergo self aldol condensation in the presence of cold dilute alkali?

- (A) $CH_2 = CH - CHO$
 - (B) $CH \equiv C - CHO$
 - (C) C_6H_5CHO
 - (D) CH_3CH_2CHO
-

82. An alkene X on ozonolysis gives a mixture of Propan-2-one and methanal. What is X?

- (A) Propene
 - (B) 2-Methylpropene
 - (C) 2-Methylbut-1-ene
 - (D) 2-Methylbut-2-ene
-

83. Cheilosis and digestive disorders are due to deficiency of:

- (A) Vitamin A
 - (B) Thiamine
 - (C) Riboflavin
 - (D) Ascorbic acid
-

84. A tetrapeptide is made of naturally occurring alanine, serine, glycine, and valine. If the C-terminal amino acid is alanine and the N-terminal amino acid is chiral, the number of possible sequences of the tetrapeptide is:

- (A) 4
 - (B) 8
 - (C) 6
 - (D) 12
-

85. Which one of the following is a water-soluble vitamin that is not excreted easily?

- (A) Vitamin B₂
 - (B) Vitamin B₁
 - (C) Vitamin B₆
 - (D) Vitamin B₁₂
-

86. Glycosidic linkage between C₁ of α -glucose and C₂ of β -fructose is found in:

- (A) maltose
 - (B) sucrose
 - (C) lactose
 - (D) amylose
-

87. The naturally occurring amino acid that contains only one basic functional group in its chemical structure is:

- (A) arginine
 - (B) lysine
 - (C) asparagine
 - (D) histidine
-

88. Which of the following is not a semi-synthetic polymer?

- (A) Cis-polyisoprene
 - (B) Cellulose nitrate
 - (C) Cellulose acetate
 - (D) Vulcanised rubber
-

89. Zinc acetate - antimony trioxide catalyst is used in the preparation of which polymer?

- (A) High-density polyethylene
 - (B) Teflon
 - (C) Terylene
 - (D) PVC
-

90. is a potent vasodilator.

- (A) Histamine
 - (B) Serotonin
 - (C) Codeine
 - (D) Cimetidine
-

Mathematics

1. Roots of the equation $x^2 + bx - c = 0$ ($b, c > 0$) are:

- (A) Both positive
 - (B) Both negative
 - (C) Of opposite sign
 - (D) None of the above
-

2. Rational roots of the equation $2x^4 + x^3 - 11x^2 + x + 2 = 0$ are:

- (A) $\frac{1}{2}, 2$
 - (B) $\frac{1}{3}, 2, -2$
 - (C) $\frac{1}{2}, 2, 3, 4$
 - (D) $\frac{1}{2}, 2, 3, -2$
-

3. If $\tan 15^\circ$ and $\tan 30^\circ$ are the roots of the equation $x^2 + px + q = 0$, then $pq =$:

- (A) $\frac{6\sqrt{3}+10}{\sqrt{3}}$
 - (B) $\frac{10-6\sqrt{3}}{3}$
 - (C) $\frac{10+6\sqrt{3}}{3}$
 - (D) $\frac{10-6\sqrt{3}}{\sqrt{3}}$
-

4. The points represented by the complex numbers $1 + i, -2 + 3i, \frac{5}{3}i$ on the Argand plane are:

- (A) Vertices of an equilateral triangle
- (B) Vertices of an isosceles triangle
- (C) Collinear
- (D) None of the above

5. The modulus of the complex number z such that $|z + 3 - i| = 1$ and $\arg(z) = \pi$ is equal to:

- (A) 3
 - (B) 2
 - (C) 9
 - (D) 4
-

6. If $z, \bar{z}, -z, -\bar{z}$ forms a rectangle of area $2\sqrt{3}$ square units, then one such z is:

- (A) $\frac{1}{2} + \sqrt{3}i$
 - (B) $\frac{\sqrt{5} + \sqrt{3}i}{4}$
 - (C) $\frac{3}{2} + \frac{\sqrt{3}i}{2}$
 - (D) $\frac{\sqrt{3} + \sqrt{11}i}{2}$
-

7. If z_1, z_2, \dots, z_n are complex numbers such that $|z_1| = |z_2| = \dots = |z_n| = 1$, then

$|z_1 + z_2 + \dots + z_n|$ is equal to:

- (A) $|z_1||z_2|\dots|z_n|$
 - (B) $|z_1| + |z_2| + \dots + |z_n|$
 - (C) $\frac{1}{|z_1|} + \frac{1}{|z_2|} + \dots + \frac{1}{|z_n|}$
 - (D) n
-

8. If $|z_1| = 2, |z_2| = 3, |z_3| = 4$ and $|2z_1 + 3z_2 + 4z_3| = 4$, then the absolute value of

$8z_2z_3 + 27z_3z_1 + 64z_1z_2$ equals:

- (A) 24
 - (B) 48
 - (C) 72
 - (D) 96
-

9. A person invites a party of 10 friends at dinner and places so that 4 are on one round table and 6 on the other round table. Total number of ways in which he can arrange the guests is:

- (A) $\frac{10!}{6!}$
 - (B) $\frac{10!}{24}$
 - (C) $\frac{9!}{24}$
 - (D) None of these
-

10. How many different nine-digit numbers can be formed from the number 223355888 by rearranging its digits so that the odd digits occupy even positions?

- (A) 16
 - (B) 36
 - (C) 60
 - (D) 100
-

11. If ${}^{22}P_{r+1} : {}^{20}P_{r+2} = 11 : 52$, then r is equal to:

- (A) 3
 - (B) 5
 - (C) 7
 - (D) 9
-

12. At an election, a voter may vote for any number of candidates not exceeding the number to be elected. If 4 candidates are to be elected out of the 12 contested in the election and voter votes for at least one candidate, then the number of ways of selections is:

- (A) 793
 - (B) 298
 - (C) 781
 - (D) 1585
-

13. The number of arrangements of all digits of 12345 such that at least 3 digits will not come in its position is:

- (A) 89
- (B) 109

(C) 78

(D) 57

14. If $a > 0, b > 0, c > 0$ and a, b, c are distinct, then $(a + b)(b + c)(c + a)$ is greater than:

(A) $2(a + b + c)$

(B) $3(a + b + c)$

(C) $6abc$

(D) $8abc$

15. If $\sum_{k=1}^n k(k+1)(k-1) = pn^4 + qn^3 + tn^2 + sn$, where p, q, t, s are constants, then the value of s is equal to:

(A) $-1/4$

(B) $-1/2$

(C) $1/2$

(D) $1/4$

16. There are four numbers of which the first three are in GP and the last three are in AP, whose common difference is 6. If the first and the last numbers are equal, then the two other numbers are:

(A) -2, 4

(B) 4, 2

(C) 2, 6

(D) None of the above

17. If $A = 1 + r^a + r^{2a} + r^{3a} + \dots \infty$ and $B = 1 + r^b + r^{2b} + r^{3b} + \dots \infty$, then $\frac{a}{b}$ is equal.

(A) $\log_b(A)$

(B) $\log_{1-b}(1 - A)$

(C) $\log_{\frac{b-1}{b}}\left(\frac{A-1}{A}\right)$

(D) None of these

18. The sum of the infinite series $1 + \frac{5}{6} + \frac{12}{6^2} + \frac{22}{6^3} + \frac{35}{6^4} + \dots$ is equal to:

(A) $\frac{425}{216}$

- (B) $\frac{429}{216}$
(C) $\frac{288}{125}$
(D) $\frac{280}{125}$
-

19. If $\tan^{-1}\left(\frac{1}{1+1\cdot 2}\right) + \tan^{-1}\left(\frac{1}{1+2\cdot 3}\right) + \dots + \tan^{-1}\left(\frac{1}{1+n(n+1)}\right) = \tan^{-1}(x)$, then x is equal to:

- (A) $\frac{1}{n+1}$
(B) $\frac{n}{n+1}$
(C) $\frac{1}{n+2}$
(D) $\frac{n}{n+2}$
-

20. If the arithmetic mean of two distinct positive real numbers a and b (where $a > b$) is twice their geometric mean, then $a : b$ is:

- (A) $2 + \sqrt{3} : 2 - \sqrt{3}$
(B) $2 + \sqrt{5} : 2 - \sqrt{5}$
(C) $2 + \sqrt{2} : 2 - \sqrt{2}$
(D) None of these
-

21. If

$$y = \tan^{-1}\left(\frac{1}{x^2 + x + 1}\right) + \tan^{-1}\left(\frac{1}{x^2 + 3x + 3}\right) + \tan^{-1}\left(\frac{1}{x^2 + 5x + 7}\right) + \dots \text{ (to } n \text{ terms)}$$

, then $\frac{dy}{dx}$ is:

- (A) $\frac{1}{x^2+n^2} - \frac{1}{x^2+1}$
(B) $\frac{1}{(x+n)^2+1} - \frac{1}{x^2+1}$
(C) $\frac{1}{x^2+(n+1)^2} - \frac{1}{x^2+1}$
(D) None of these
-

22. The coefficient of x^2 term in the binomial expansion of $\left(\frac{1}{3}x^{\frac{1}{2}} + x^{-\frac{1}{4}}\right)^{10}$ is:

- (A) $\frac{70}{243}$
(B) $\frac{60}{423}$
(C) $\frac{50}{13}$
(D) None of these

23. The coefficient of x^n in the expansion of

$$\frac{e^{7x} + e^x}{e^{3x}}$$

is:

- (A) $\frac{4^{n-1} \cdot (-2)^n}{n!}$
 - (B) $\frac{4^n - 1 \cdot (2)^n}{n!}$
 - (C) $\frac{4^n + (-2)^n}{n!}$
 - (D) $\frac{4^n - 1 \cdot (-2)^{n-1}}{n!}$
-

24. The coefficient of the highest power of x in the expansion of

$(x + \sqrt{x^2 - 1})^8 + (x - \sqrt{x^2 - 1})^8$ **is:**

- (A) 64
 - (B) 128
 - (C) 256
 - (D) 512
-

25. If the 17th and the 18th terms in the expansion of $(2 + a)^{50}$ are equal, then the coefficient of x^{35} in the expansion of $(a + x)^{-2}$ is:

- (A) -35
 - (B) 3
 - (C) 36
 - (D) -36
-

26. Let A, B and C are the angles of a triangle and $\tan \frac{A}{2} = 1/3, \tan \frac{B}{2} = \frac{2}{3}$. Then, $\tan \frac{C}{2}$ is equal to:

- (A) $\frac{7}{9}$
 - (B) $\frac{2}{9}$
 - (C) $\frac{1}{3}$
 - (D) $\frac{2}{3}$
-

27. The sum of all values of x in $[0, 2\pi]$, for which $\sin(x) + \sin(2x) + \sin(3x) + \sin(4x) = 0$

is equal to:

- (A) 8π
 - (B) 11π
 - (C) 12π
 - (D) 9π
-

28. Number of solutions of equations $\sin(9\theta) = \sin(\theta)$ in the interval $[0, 2\pi]$ is:

- (A) 16
 - (B) 17
 - (C) 18
 - (D) 15
-

29. The range of $(8 \sin(\theta) + 6 \cos(\theta))^2 + 2$ is:

- (A) (0,2)
 - (B) [2,102]
 - (C) $(-\infty, \infty)$
 - (D) (2,1)
-

30. The locus of the point of intersection of the lines $x = a(1 - t^2)/(1 + t^2)$ and $y = 2at/(1 + t^2)$ (t being a parameter) represents:

- (A) Circle
 - (B) Parabola
 - (C) Ellipse
 - (D) Hyperbola
-

31. If the straight line $2x + 3y - 1 = 0$, $x + 2y - 1 = 0$ and $ax + by - 1 = 0$ form a triangle with origin as orthocentre, then (a, b) is equal to:

- (A) (6,4)
 - (B) (-3,3)
 - (C) (-8,8)
 - (D) (0,7)
-

33. The distance from the origin to the image of $(1, 1)$ with respect to the line

$x + y + 5 = 0$ **is:**

- (A) $7\sqrt{2}$
 - (B) $3\sqrt{2}$
 - (C) $6\sqrt{2}$
 - (D) $4\sqrt{2}$
-

34. $A(3,2,0)$, $B(5,3,2)$, $C(-9,6,-3)$ are three points forming a triangle. AD , the bisector of angle BAC meets BC in D . Find the coordinates of D :

- (A) $(\frac{19}{8}, \frac{57}{15}, \frac{57}{15})$
 - (B) $(\frac{19}{8}, \frac{57}{16}, \frac{17}{16})$
 - (C) $(2,3,0)$
 - (D) $(4,5,6)$
-

35. The locus of the mid-point of a chord of the circle $x^2 + y^2 = 4$ which subtends a right angle at the origin is:

- (A) $x + y = 2$
 - (B) $x^2 + y^2 = 1$
 - (C) $x^2 + y^2 = 2$
 - (D) $x + y = 1$
-

36. If p and q be the longest and the shortest distance respectively of the point $(-7,2)$ from any point (α, β) on the curve whose equation is

$$x^2 + y^2 - 10x - 14y - 51 = 0$$

then the geometric mean (G.M.) of p is:

- (A) $2\sqrt{11}$
 - (B) $5\sqrt{5}$
 - (C) 13
 - (D) 11
-

37. From a point A(0,3) on the circle

$$(x + 2)^2 + (y - 3)^2 = 4$$

a chord AB is drawn and extended to a point Q such that AQ = 2AB. Then the locus of Q is:

- (A) $(x + 4)^2 + (y - 3)^2 = 16$
 - (B) $(x + 1)^2 + (y - 3)^2 = 32$
 - (C) $(x + 1)^2 + (y - 3)^2 = 4$
 - (D) $(x + 1)^2 + (y - 3)^2 = 1$
-

38. If the focus of the parabola

$$(y - k)^2 = 4(x - h)$$

always lies between the lines $x + y = 1$ and $x + y = 3$ then:

- (A) $0 < h + k < 2$
 - (B) $0 < h + k < 1$
 - (C) $1 < h + k < 2$
 - (D) $1 < h + k < 3$
-

39. Let L_1 be the length of the common chord of the curves

$$x^2 + y^2 = 9 \quad \text{and} \quad y^2 = 8x$$

and let L_2 be the length of the latus rectum of $y^2 = 8x$. Then:

- (A) $L_1 > L_2$
 - (B) $L_1 = L_2$
 - (C) $L_1 < L_2$
 - (D) $\frac{L_1}{L_2} = \sqrt{2}$
-

40. The foci of the hyperbola

$$4x^2 - 9y^2 - 1 = 0$$

are:

- (A) $(\pm\sqrt{13}, 0)$

- (B) $\left(\pm\frac{\sqrt{13}}{6}, 0\right)$
 (C) $\left(0, \pm\frac{\sqrt{3}}{6}\right)$
 (D) None of these
-

41. Given a real-valued function f such that:

$$f(x) = \begin{cases} \frac{\tan^2\{x\}}{x^2 - [x]^2}, & \text{for } x > 0 \\ 1, & \text{for } x = 0 \\ \sqrt{\{x\} \cot\{x\}}, & \text{for } x < 0 \end{cases}$$

Then:

- (A) LHL = 1
 (B) RHL = $\sqrt{\cot 1}$
 (C) $\lim_{x \rightarrow 0} f(x)$ exists
 (D) $\lim_{x \rightarrow 0} f(x)$ does not exist
-

42. Let $f(x) = \sin x$, $g(x) = \cos x$, and $h(x) = x^2$. Then, evaluate:

$$\lim_{x \rightarrow 1} \frac{f(g(h(x))) - f(g(h(1)))}{x - 1}$$

- (A) 0
 (B) $-2 \sin 1 \cos(\cos 1)$
 (C) ∞
 (D) $-2 \sin 1 \cos 1$
-

43. The Boolean expression:

$$\sim (p \vee q) \vee (\sim p \wedge q)$$

is equivalent to:

- (A) p
 (B) q
 (C) $\sim q$

(D) $\sim p$

44. If p : 2 is an even number, q : 2 is a prime number, and r : $2 + 2 = 2^2$, then the symbolic statement $p \rightarrow (q \vee r)$ means:

(A) 2 is an even number and 2 is a prime number or $2 + 2 = 2^2$

(B) 2 is an even number then 2 is a prime number or $2 + 2 = 2^2$

(C) 2 is an even number or 2 is a prime number then $2 + 2 = 2^2$

(D) If 2 is not an even number then 2 is a prime number $\alpha = 2 + 2 = 2^2$

45. Consider the following statements:

A: Rishi is a judge.

B: Rishi is honest.

C: Rishi is not arrogant.

The negation of the statement "If Rishi is a judge and he is not arrogant, then he is honest" is:

(A) $B \rightarrow (A \vee C)$

(B) $(\sim B) \wedge (A \wedge C)$

(C) $B \rightarrow ((\sim A) \vee (\sim C))$

(D) $B \rightarrow (A \wedge C)$

46. If p : It is raining today, q : I go to school, r : I shall meet my friends, and s : I shall go for a movie, then which of the following represents:

"If it does not rain or if I do not go to school, then I shall meet my friend and go for a movie?"

(A) $\sim (p \wedge q) \Rightarrow (r \wedge s)$

(B) $\sim (p \wedge \sim q) \Rightarrow (r \wedge s)$

(C) $\sim (p \wedge q) \Rightarrow (r \vee s)$

(D) None of these

47. Let p, q, r be three logical statements. Consider the compound statements:

$$S_1 : (\sim p \vee q) \vee (\sim p \vee r)$$

$$S_2 : p \rightarrow (q \vee r)$$

Which of the following is NOT true?

- (A) If S_2 is true, then S_1 is true
 - (B) If S_2 is false, then S_1 is false
 - (C) If S_2 is false, then S_1 is true
 - (D) If S_1 is false, then S_2 is false
-

48. Consider the following two propositions:

$$P_1 : \sim (p \rightarrow \sim q)$$

$$P_2 : (p \wedge \sim q) \wedge ((\sim p) \vee q)$$

If the proposition $p \rightarrow ((\sim p) \vee q)$ is evaluated as FALSE, then:

- (A) P_1 is TRUE and P_2 is FALSE
 - (B) P_1 is FALSE and P_2 is TRUE
 - (C) Both P_1 and P_2 are FALSE
 - (D) Both P_1 and P_2 are TRUE
-

49. If the variance of the data 2, 3, 5, 8, 12 is σ^2 and the mean deviation from the median for this data is M , then $\sigma^2 - M$ is:

- (A) 10.2
 - (B) 5.8
 - (C) 10.6
 - (D) 8.2
-

50. The mean of n items is X . If the first item is increased by 1, second by 2, and so on, the new mean is:

- (A) $\bar{X} + \frac{x}{2}$
(B) $\bar{X} + x$
(C) $\bar{X} + \frac{n+1}{2}$
(D) None of these
-

51. The variance of 20 observations is 5. If each observation is multiplied by 2, then the new variance of the resulting observation is:

- (A) $2^3 \times 5$
(B) $2^2 \times 5$
(C) 2×5
(D) $2^4 \times 5$
-

52. If the function $f(x)$, defined below, is continuous on the interval $[0, 8]$, then:

$$f(x) = \begin{cases} x^2 + ax + b, & 0 \leq x < 2 \\ 3x + 2, & 2 \leq x \leq 4 \\ 2ax + 5b, & 4 < x \leq 8 \end{cases}$$

- (A) $a = 3, b = -2$
(B) $a = -3, b = 2$
(C) $a = -3, b = -2$
(D) $a = 3, b = 2$
-

53. From the top of a cliff 50 m high, the angles of depression of the top and bottom of a tower are observed to be 30° and 45° . The height of the tower is:

- (A) 50 m
(B) $50\sqrt{3}$ m
(C) $50(\sqrt{3} - 1)$ m
(D) $50 \left(1 - \frac{\sqrt{3}}{3}\right)$ m
-

54. ABC is a triangular park with $AB = AC = 100$ m. A TV tower stands at the midpoint of BC . The angles of elevation of the top of the tower at A, B, C are

$45^\circ, 60^\circ, 60^\circ$ respectively. The height of the tower is:

- (A) 50 m
 - (B) $50\sqrt{3}$ m
 - (C) $50\sqrt{2}$ m
 - (D) $50(3 - \sqrt{3})$ m
-

55. In a statistical investigation of 1003 families of Calcutta, it was found that 63 families have neither a radio nor a TV, 794 families have a radio, and 187 have a TV.

The number of families having both a radio and a TV is:

- (A) 36
 - (B) 41
 - (C) 32
 - (D) None of these
-

56. Let R be the relation "is congruent to" on the set of all triangles in a plane. Is R:

- (A) Reflexive only
 - (B) Symmetric only
 - (C) Symmetric and reflexive only
 - (D) Equivalence relation
-

57. Number of subsets of set of letters of word 'MONOTONE' is:

- (A) 8
 - (B) 256
 - (C) 64
 - (D) 32
-

58. In an examination, 62% of the candidates failed in English, 42% in Mathematics and 20% in both. The number of those who passed in both the subjects is:

- (A) 11
- (B) 16
- (C) 18

(D) None of these

59. If $A = \frac{1}{3} \begin{bmatrix} 1 & 2 & 2 \\ 2 & 1 & -2 \\ a & 2 & b \end{bmatrix}$ is an orthogonal matrix, then

(A) $a = -2, b = -1$

(B) $a = 2, b = 1$

(C) $a = 2, b = -1$

(D) $a = -2, b = 1$

60. If matrix $A = \begin{bmatrix} 3 & -2 & 4 \\ 1 & 2 & -1 \\ 0 & 1 & 1 \end{bmatrix}$ and $A^{-1} = \frac{1}{k} \text{adj}(A)$, then k is

(A) 7

(B) -7

(C) 15

(D) -11

61. If A and B are symmetric matrices of the same order such that $AB + BA = X$ and $AB - BA = Y$, then $(XY)^T =$

(A) XY

(B) $X^T Y^T$

(C) $-YX$

(D) $-Y^T X^T$

62. If $A = \begin{bmatrix} 1 & 0 \\ 0 & -1 \end{bmatrix}$, $P = \begin{bmatrix} 1 & 1 \\ 0 & 1 \end{bmatrix}$ and $X = APA^T$, then $A^T X^{50} A$ is:

(A) $\begin{bmatrix} 0 & 1 \\ 1 & 0 \end{bmatrix}$

- (B) $\begin{bmatrix} 2 & 1 \\ 0 & -1 \end{bmatrix}$
- (C) $\begin{bmatrix} 25 & 1 \\ 1 & -25 \end{bmatrix}$
- (D) $\begin{bmatrix} 1 & 50 \\ 0 & 1 \end{bmatrix}$
-

63. If A is a square matrix of order 3, then $|\text{Adj}(\text{Adj } A^2)|$ is:

- (A) $|A|^2$
- (B) $|A|^4$
- (C) $|A|^8$
- (D) $|A|^{16}$
-

64. Suppose $p, q, r \neq 0$ and the system of equations:

$$(p + a)x + by + cz = 0$$

$$ax + (q + b)y + cz = 0$$

$$ax + by + (r + c)z = 0$$

has a non-trivial solution, then the value of

$$\frac{a}{p} + \frac{b}{q} + \frac{c}{r}$$

is:

- (A) -1
- (B) 0
- (C) 1
- (D) 2
-

65. If x is a complex root of the equation

$$\begin{vmatrix} 1 & x & x \\ x & 1 & x \\ x & x & 1 \end{vmatrix} + \begin{vmatrix} 1-x & 1 & 1 \\ 1 & 1-x & 1 \\ 1 & 1 & 1-x \end{vmatrix} = 0,$$

then $x^{2007} + x^{-2007}$ is:

- (A) 1
- (B) -1
- (C) -2
- (D) 2

66. The system of equations:

$$x - y + 2z = 4$$

$$3x + y + 4z = 6$$

$$x + y + z = 1$$

has:

- (A) unique solution
- (B) infinitely many solutions
- (C) no solution
- (D) two solutions

67. If the system of linear equations:

$$2x + y - z = 7$$

$$x - 3y + 2z = 1$$

$$x + 4y + \delta z = k$$

has infinitely many solutions, then $\delta + k$ is:

- (A) -3
- (B) 3
- (C) 6

(D) 9

68. If $\cot(\cos^{-1} x) = \sec\left(\tan^{-1}\left(\frac{a}{\sqrt{b^2-a^2}}\right)\right)$, then:

- (A) $\frac{b}{\sqrt{2b^2-a^2}}$
 - (B) $\frac{\sqrt{b^2-a^2}}{ab}$
 - (C) $\frac{a}{\sqrt{2b^2-a^2}}$
 - (D) $\frac{\sqrt{b^2-a^2}}{a}$
-

69. If $\cos \cot^{-1}\left(\frac{1}{2}\right) = \cot(\cos^{-1} x)$, then the value of x is:

- (A) $\frac{1}{\sqrt{6}}$
 - (B) $\frac{-1}{\sqrt{12}}$
 - (C) $\frac{2}{\sqrt{6}}$
 - (D) $\frac{-2}{\sqrt{6}}$
-

70. Let $[x]$ denote the greatest integer $\leq x$. If $f(x) = [x]$ and $g(x) = |x|$, then the value of:

$$f\left(g\left(\frac{8}{5}\right)\right) - g\left(f\left(\frac{-8}{5}\right)\right)$$

is:

- (A) 2
 - (B) -2
 - (C) 1
 - (D) -1
-

71. The number of real solutions of

$$\sqrt{5 - \log_2 |x|} = 3 - \log_2 |x|$$

is:

- (A) 1
- (B) 2
- (C) 3
- (D) 4

72. The function

$$f(x) = \frac{\cos x}{\left[\frac{2x}{\pi}\right] + \frac{1}{2}},$$

where x is not an integral multiple of π and $[\cdot]$ denotes the greatest integer function, is:

- (A) an odd function
 - (B) an even function
 - (C) neither odd nor even
 - (D) None of these
-

73. The function $f: \mathbb{R} \rightarrow \mathbb{R}$ is defined by

$$f(x) = \frac{x}{\sqrt{1+x^2}}$$

is:

- (A) surjective but not injective
 - (B) bijective
 - (C) injective but not surjective
 - (D) neither injective nor surjective
-

74. If $f: \mathbb{R} \rightarrow \mathbb{R}$, $g: \mathbb{R} \rightarrow \mathbb{R}$ are defined by $f(x) = 5x - 3$, $g(x) = x^2 + 3$, then $g \circ f^{-1}(3)$ is equal to

- (A) $\frac{25}{3}$
 - (B) $\frac{111}{25}$
 - (C) $\frac{9}{25}$
 - (D) $\frac{25}{111}$
-

75. The domain of the real-valued function

$$f(x) = \sqrt{\frac{2x^2 - 7x + 5}{3x^2 - 5x - 2}}$$

is:

- (A) $(-\infty, -\frac{1}{3}) \cup [1, 2) \cup [\frac{5}{2}, \infty)$
- (B) $(-\infty, 1) \cup (2, \infty)$

(C) $(-\frac{1}{3}, \frac{5}{2})$

(D) $(-\infty, -\frac{1}{3}] \cup [\frac{5}{2}, \infty)$

76. If a function $f : \mathbb{R} \setminus \{1\} \rightarrow \mathbb{R} \setminus \{m\}$ defined by $f(x) = \frac{x+3}{x-2}$ is a bijection, then

$3/l + 2m =$

(A) 10

(B) 12

(C) 8

(D) 14

77. Given that $f(x) = \sin x + \cos x$ and $g(x) = x^2 - 1$, find the conditions under which $g(f(x))$ is invertible.

(A) $-\frac{\pi}{4} \leq x \leq \frac{\pi}{4}$

(B) $0 \leq x \leq \pi$

(C) $-\frac{\pi}{4} \leq x \leq \pi$

(D) $0 \leq x \leq \frac{\pi}{2}$

78. Let the function $g : (-\infty, -0) \rightarrow (-\frac{\pi}{2}, \frac{\pi}{2})$ be given by $g(u) = 2 \tan^{-1}(e^u) - \frac{\pi}{2}$.

Determine the properties of g .

(A) Even and is strictly increasing in $(0, \infty)$

(B) Odd and is strictly decreasing in $(-\infty, 0)$

(C) Odd and is strictly increasing in $(-\infty, \infty)$

(D) Neither even nor odd, but is strictly increasing in $(-\infty, \infty)$

79. Let f be the function defined by:

$$f(x) = \begin{cases} \frac{x^2-1}{x^2-2|x-1|-1}, & \text{if } x \neq 1, \\ \frac{1}{2}, & \text{if } x = 1. \end{cases}$$

The function is continuous at:

(A) The function is continuous for all values of x

(B) The function is continuous only for $x > 1$

- (C) The function is continuous at $x = 1$
(D) The function is not continuous at $x = 1$
-

80. If

$$f(x) = \begin{cases} \frac{x^2 \log(\cos x)}{\log(1+x)}, & x \neq 0 \\ 0, & x = 0 \end{cases}$$

then at $x = 0$, $f(x)$ is .

- (A) not continuous
(B) continuous but not differentiable
(C) differentiable
(D) not continuous, but differentiable
-

81. If $f(x)$ is defined as follows:

$$f(x) = \begin{cases} 4, & \text{if } -\infty < x < -\sqrt{5}, \\ x^2 - 1, & \text{if } -\sqrt{5} \leq x \leq \sqrt{5}, \\ 4, & \text{if } \sqrt{5} \leq x < \infty. \end{cases}$$

If k is the number of points where $f(x)$ is not differentiable, then $k - 2 =$

- (A) 2
(B) 1
(C) 0
(D) 3
-

82. If $x\sqrt{1+y} + y\sqrt{1+x} = 0$, then find $\frac{dy}{dx}$.

- (A) $x + \frac{1}{x}$
(B) $\frac{1}{1+x}$
(C) $-\frac{1}{(1+x)^2}$
(D) $\frac{x}{1+x}$
-

83. If $y = \tan^{-1} \left(\frac{\sqrt{x-x}}{1+x^{3/2}} \right)$, then $y'(1)$ is equal to:

- (A) 0

(B) $\frac{1}{2}$

(C) -1

(D) $-\frac{1}{4}$

84. At $x = \frac{\pi^2}{4}$, $\frac{d}{dx} (\tan^{-1}(\cos \sqrt{x}) + \sec^{-1}(e^x)) =$

(A) $\frac{1}{\sqrt{e^{\frac{\pi^2}{2}} - 1}} - \frac{1}{\pi}$

(B) $\frac{\pi}{4} + \frac{1}{\sqrt{e^{\pi^2} + e^{\frac{\pi^2}{2}}}}$

(C) $\frac{1}{\sqrt{e^{\pi^2} + e^{\frac{\pi^2}{2}}}} + \frac{2}{\pi} \cot\left(\frac{\pi}{2}\right)$

(D) $\frac{1}{\sqrt{e^\pi}} + \frac{1}{\pi}$

85. The maximum area of a rectangle inscribed in a circle of diameter R is:

(A) R^2

(B) $\frac{R^2}{2}$

(C) $\frac{R^2}{4}$

(D) $\frac{R^2}{8}$

86. Consider the function $f(x) = \frac{|x-1|}{x^2}$. Then $f(x)$ is:

(A) Increasing in $(0, 1) \cup (2, \infty)$

(B) Increasing in $(-\infty, 0) \cup (0, 1)$

(C) Decreasing in $(-\infty, 0) \cup (2, \infty)$

(D) Decreasing in $(0, 1) \cup (2, \infty)$

87. The maximum volume (in cu. units) of the cylinder which can be inscribed in a sphere of radius 12 units is:

(A) $384\sqrt{3}\pi$

(B) $768\sqrt{3}\pi$

(C) $768\pi/\sqrt{3}$

(D) $1152\pi/\sqrt{3}$

88. If the angle made by the tangent at the point (x_0, y_0) on the curve

$x = 12(t + \sin t \cos t)$, $y = 12(1 + \sin t)^2$, with $0 < t < \frac{\pi}{2}$, with the positive x-axis is $\frac{\pi}{3}$, then y_0 is equal to:

- (A) $6(3 + 2\sqrt{2})$
 - (B) $3(7 + 4\sqrt{3})$
 - (C) 27
 - (D) 48
-

89. The altitude of a cone is 20 cm and its semi-vertical angle is 30° . If the semi-vertical angle is increasing at the rate of 2° per second, then the radius of the base is increasing at the rate of:

- (A) 30 cm/sec
 - (B) $\frac{160}{3}$ cm/sec
 - (C) 10 cm/sec
 - (D) 160 cm/sec
-

90. The point of inflexion for the curve $y = (x - a)^n$, where n is odd integer and $n \geq 3$, is:

- (A) $(a, 0)$
 - (B) $(0, a)$
 - (C) $(0, 0)$
 - (D) None of these
-

91. The population $p(t)$ at time t of a certain mouse species satisfies the differential equation:

$$\frac{dp(t)}{dt} = 0.5p(t) - 450.$$

If $p(0) = 850$, then the time at which the population becomes zero is:

- (A) $2 \ln 18$
 - (B) $\ln 9$
 - (C) $\frac{1}{2} \ln 18$
 - (D) $\ln 18$
-

92. Evaluate the integral:

$$\int \frac{x^3 - 1}{x^3 + x} dx$$

- (A) $x + \log|x| + \frac{1}{2} \log(x^2 + 1) + \sin^{-1}(x) + c$
(B) $x - \log|x| + \frac{1}{2} \log(x^2 + 1) - \sin^{-1}(x) + c$
(C) $x + \log|x| - \frac{1}{2} \log(x^2 + 1) + \tan^{-1}(x) + c$
(D) $x - \log|x| + \frac{1}{2} \log(x^2 + 1) - \tan^{-1}(x) + c$
-

93. Evaluate the integral:

$$\int \sqrt{x + \sqrt{x^2 + 2}} dx.$$

- (A) $\frac{2}{3}(x + \sqrt{x^2 + 2})^{3/2} - 2(x + \sqrt{x^2 + 2})^{1/2} + C$
(B) $\frac{1}{3}(x + \sqrt{x^2 + 2})^{3/2} - 2(x + \sqrt{x^2 + 2})^{1/2} + C$
(C) $(x + \sqrt{x^2 + 2})^{-3/2} - 2(x + \sqrt{x^2 + 2})^{1/2} + C$
(D) $\frac{(x + \sqrt{x^2 + 2})^2 - 6}{3\sqrt{x + \sqrt{x^2 + 2}}} + C$
-

94. The value of $\int e^{\tan \theta} (\sec \theta - \sin \theta) d\theta$ is:

- (A) $e^{\tan \theta} \sec \theta + c$
(B) $e^{\tan \theta} \sin \theta + c$
(C) $e^{\tan \theta} (\tan \theta + \sin \theta) + c$
(D) $e^{\tan \theta} \cos \theta + c$
-

95. The value of $\int_0^\infty \frac{dx}{(x^2 + a^2)(x^2 + b^2)}$ is:

- (A) $\frac{\pi ab}{a+b}$
(B) $\frac{ab}{2(a+b)}$
(C) $\frac{\pi}{2ab(a+b)}$
(D) $\frac{\pi(a+b)}{2ab}$
-

96. The value of definite integral $\int_0^{\pi/2} \log(\tan x) dx$ is:

- (A) 0
(B) $\frac{\pi}{4}$
(C) $\frac{\pi}{2}$

(D) π

97. Evaluate the integral:

$$\int_5^9 \frac{\log 3x^2}{\log 3x^2 + \log(588 - 84x + 3x^2)} dx$$

(A) 2

(B) 1

(C) $\frac{1}{2}$

(D) 4

98. Evaluate the integral:

$$\int \frac{x^2(x \sec^2 x + \tan x)}{(x \tan x + 1)^2} dx$$

(A) $-\frac{x^2}{x \tan x + 1}$

(B) $2 \log_e |x \sin x + \cos x| + C$

(C) $-\frac{x^2}{x \tan x + 1} + 2 \log_e |x \sin x + \cos x| + C$

(D) $-\frac{x^2}{x \tan x + 1} - 2 \log_e |x \sin x + \cos x| + C$

99. Evaluate the following limit:

$$\lim_{n \rightarrow \infty} \prod_{r=3}^n \frac{r^3 - 8}{r^3 + 8}$$

(A) $\frac{2}{7}$

(B) $\frac{3}{7}$

(C) $\frac{4}{7}$

(D) $\frac{6}{7}$

100. The value of $\int_0^{\frac{\pi}{2}} \frac{\sin(\frac{\pi}{4}+x) + \sin(\frac{3\pi}{4}+x)}{\cos x + \sin x} dx$ is:

(A) $\frac{\pi}{\sqrt{2}}$

(B) $\frac{\pi}{2\sqrt{2}}$

(C) $\frac{\pi}{3\sqrt{2}}$

(D) $\frac{\pi}{4\sqrt{2}}$

101. The line $y = mx$ bisects the area enclosed by lines $x = 0$, $y = 0$, and $x = \frac{3}{2}$ and the curve $y = 1 + 4x - x^2$. Then, the value of m is:

- (A) $\frac{13}{6}$
 - (B) $\frac{13}{2}$
 - (C) $\frac{13}{5}$
 - (D) $\frac{13}{7}$
-

102. If a, c, b are in GP, then the area of the triangle formed by the lines $ax + by + c = 0$ with the coordinate axes is equal to:

- (A) 1
 - (B) 2
 - (C) $\frac{1}{2}$
 - (D) None of these
-

103. The area enclosed by the curves $y = x^3$ and $y = \sqrt{x}$ is:

- (A) $\frac{5}{3}$ sq. units
 - (B) $\frac{5}{4}$ sq. units
 - (C) $\frac{5}{12}$ sq. units
 - (D) $\frac{12}{5}$ sq. units
-

104. The area of the region bounded by the curves $x = y^2 - 2$ and $x = y$ is:

- (A) $\frac{9}{4}$
 - (B) 9
 - (C) $\frac{9}{2}$
 - (D) $\frac{9}{7}$
-

105. If the area bounded by the curves $y = ax^2$ and $x = ay^2$ (where $a > 0$) is 3 sq. units, then the value of a is:

- (A) $\frac{2}{3}$
- (B) $\frac{1}{3}$
- (C) 1

(D) 4

106. The solution of the differential equation $(x + 1)\frac{dy}{dx} - y = e^{3x}(x + 1)^2$ is:

- (A) $y = (x + 1)e^{3x} + C$
 - (B) $3y = (x + 1) + e^{3x} + C$
 - (C) $\frac{3y}{x+1} = e^{3x} + C$
 - (D) $ye^{-3x} = 3(x + 1) + C$
-

107. If $\frac{dy}{dx} - y \log_e 2 = 2^{\sin x} (\cos x - 1) \log_e 2$, then y is:

- (A) $2^{\sin x} + c2^x$
 - (B) $2^{\cos x} + c2^x$
 - (C) $2^{\sin x} + c2^{-x}$
 - (D) $2^{\cos x} + c2^{-x}$
-

108. Let $\mathbf{a} = \hat{i} - \hat{k}$, $\mathbf{b} = x\hat{i} + \hat{j} + (1 - x)\hat{k}$, and $\mathbf{c} = y\hat{i} + x\hat{j} + (1 + x - y)\hat{k}$. Then, $[\mathbf{a} \ \mathbf{b} \ \mathbf{c}]$ depends on:

- (A) only y
 - (B) only x
 - (C) both x and y
 - (D) neither x nor y
-

109. Let ABC be a triangle and $\vec{a}, \vec{b}, \vec{c}$ be the position vectors of A, B, C respectively. Let D divide BC in the ratio $3 : 1$ internally and E divide AD in the ratio $4 : 1$ internally. Let BE meet AC in F . If E divides BF in the ratio $3 : 2$ internally then the position vector of F is:

- (A) $\frac{\vec{a} + \vec{b} + \vec{c}}{3}$
 - (B) $\frac{\vec{a} - 2\vec{b} + 3\vec{c}}{2}$
 - (C) $\frac{\vec{a} + 2\vec{b} + 3\vec{c}}{2}$
 - (D) $\frac{\vec{a} - \vec{b} + 3\vec{c}}{3}$
-

110. If $\vec{a} = 2\hat{i} + \hat{j} + 2\hat{k}$, then the value of $|\hat{i} \times (\vec{a} \times \hat{i})|^2 + |\hat{j} \times (\vec{a} \times \hat{j})|^2 + |\hat{k} \times (\vec{a} \times \hat{k})|^2$ is

equal to:

- (A) 17
 - (B) 18
 - (C) 19
 - (D) 20
-

111. The magnitude of projection of the line joining $(3, 4, 5)$ and $(4, 6, 3)$ on the line joining $(-1, 2, 4)$ and $(1, 0, 5)$ is:

- (A) $\frac{4}{3}$
 - (B) $\frac{2}{3}$
 - (C) $\frac{8}{3}$
 - (D) $\frac{1}{3}$
-

112. The angle between the lines whose direction cosines are given by the equations

$3l + m + 5n = 0$ and $6nm - 2nl + 5lm = 0$ is:

- (A) $\cos^{-1} \left(\frac{1}{6} \right)$
 - (B) $\cos^{-1} \left(-\frac{1}{6} \right)$
 - (C) $\cos^{-1} \left(\frac{2}{3} \right)$
 - (D) $\cos^{-1} \left(-\frac{5}{6} \right)$
-

113. Let the acute angle bisector of the two planes $x - 2y - 2z + 1 = 0$ and $2x - 3y - 6z + 1 = 0$ be the plane P . Then which of the following points lies on P ?

- (A) $(3, 1, -\frac{1}{2})$
 - (B) $(-2, 0, -\frac{1}{2})$
 - (C) $(0, 2, -4)$
 - (D) $(4, 0, -2)$
-

114. Let the foot of perpendicular from a point $P(1, 2, -1)$ to the straight line

$L : \frac{x}{1} = \frac{y}{0} = \frac{z}{-1}$ be N . Let a line be drawn from P parallel to the plane $x + y + 2z = 0$

which meets L at point Q . If α is the acute angle between the lines PN and PQ , then

$\cos \alpha$ is equal to:

- (A) $\frac{1}{\sqrt{5}}$
 - (B) $\frac{\sqrt{3}}{2}$
 - (C) $\frac{1}{\sqrt{3}}$
 - (D) $\frac{1}{2\sqrt{3}}$
-

115. If the number of available constraints is 3 and the number of parameters to be optimised is 4, then

- (A) The objective function can be optimised
 - (B) The constraints are short in number
 - (C) The solution is problem oriented
 - (D) None of the above
-

116. The probability of getting 10 in a single throw of three fair dice is:

- (A) $\frac{1}{6}$
 - (B) $\frac{1}{8}$
 - (C) $\frac{1}{9}$
 - (D) $\frac{1}{5}$
-

117. In a binomial distribution, the mean is 4 and variance is 3. Then, its mode is:

- (A) 5
 - (B) 6
 - (C) 4
 - (D) None of these
-

118. The probability that certain electronic component fails when first used is 0.10. If it does not fail immediately, the probability that it lasts for one year is 0.99. The probability that a new component will last for one year is

- (A) 0.9
- (B) 0.01
- (C) 0.119
- (D) 0.891

119. Given below is the distribution of a random variable X :

$X = x$	$P(X = x)$
1	λ
2	2λ
3	3λ
4	4λ

If $\alpha = P(X < 3)$ and $\beta = P(X > 2)$, then $\alpha : \beta =$

- (A) $\frac{2}{5}$
- (B) $\frac{3}{4}$
- (C) $\frac{4}{5}$
- (D) $\frac{3}{7}$

120. A book contains 1000 pages. A page is chosen at random. The probability that the sum of the digits of the marked number on the page is equal to 9, is

- (A) $\frac{23}{500}$
- (B) $\frac{11}{200}$
- (C) $\frac{7}{100}$
- (D) None of these

121. For two events A and B, if $P(A) = P(A/B) = \frac{1}{4}$ and $P(B/A) = \frac{1}{2}$, then which of the following is not true?

- (A) A and B are independent
 - (B) $P(A'/B) = \frac{3}{4}$
 - (C) $P(B'/A') = \frac{1}{2}$
 - (D) None of these
-